



MiniTec
PROFILE SYSTEM

Product catalog 2019



PRODUCTS



SOLUTIONS



SERVICE

PROFILE SYSTEM

part no. 95.3010/3

All information in this catalog has been carefully checked. For any errors or incomplete information we can not accept any liability.
We reserve the right for technical changes, particularly those serving the technical improvement.

Our kit is designed primarily for indoor use. Outdoor applications require separate consideration.

Reproduction - even in part - only with our permission.

		INTRODUCTION	4	CHAPTER 2		LINEAR SYSTEMS	265
		THE COMPANY	4		2.1	LINEAR MODULE LMS 90	266
		TECHNICAL DATA	7		2.2	LINEAR MODULE LMZ 90	271
					2.3	LINEAR SYSTEM LR	273
					2.4	MINI-ADJUSTING UNITS	328
					2.5	ADJUSTING UNITS	332
					2.6	SLIDING GUIDES	336
					2.7	LINEAR SYSTEM LB	344
CHAPTER 1		PROFILE SYSTEM	14	CHAPTER 3		WORKPLACE SYSTEMS	358
	1.1	ALUMINIUM PROFILES	15		3.1	BASE FRAME	362
		PROFILE SECTIONS	15		3.2	HEIGHT ADJUSTABLE WORKSTATIONS	364
		PROFILE SERIES 30	15		3.3	TABLETOPS	373
		PROFILE SERIES 45	16		3.4	COUNTER CABINETS	377
	1.2	FASTENING ELEMENTS	64		3.5	LIGHTING	385
	1.3	HINGES & JOINTS	104		3.6	ENERGY SUPPLY	389
	1.4	HANDLES, LOCKS, STOPS	120		3.7	EQUIPMENT	391
	1.5	FEET, CASTORS, FLOOR FASTENINGS, SUPPORTS	147		3.8	FOOT RESTS	434
	1.6	FITTING OF SURFACE ELEMENTS & INSTALLATION OPTIONS	174		3.9	PNEUMATICS	436
	1.7	EDGE, COVER, SLIDE AND SEALING PROFILES	194		3.10	KANBAN-SYSTEMS	439
	1.8	READY-TO-INSTALL ELEMENTS FOR LIFTING AND SLIDING DOORS	211		3.11	LIFTER	451
	1.9	ELECTRICAL INSTALLATION	232		3.12	ASSEMBLY DEVICES	455
	1.10	DRIVE UNITS AND CONTROL SYSTEMS	248		3.13	ESD ACCESSORIES	459
	1.11	PNEUMATICS	255				
	1.12	HYDRAULICS	261				

CHAPTER 4		CONVEYORS	473	CHAPTER 7		TOOLS AND PROCESSING	574
	4.1	BELT CONVEYORS	474		7.1	TOOLS	575
	4.2	ROLLER CONVEYOR	483		7.2	PROCESSING	587
	4.3	TIMING BELT CONVEYOR	488				
	4.4	COMPONENTS	491				
	4.5	TRANSFER SYSTEM TSG	517				
	4.6	SEGMENTED CHAIN CONVEY-OR GKF	534				
	4.7	FLEXIBLE ASSEMBLY LINES FMS	538				
	4.8	ROLLER CONVEYORS RMS	540				
	4.9	PALLET CIRCULATION SYSTEM UMS	542				

CHAPTER 5		SAFETY SYSTEMS	543
	5.1	MACHINE PROTECTION	544
	5.2	PROTECTION SYSTEM SAFE GUARD	550
	5.3	NOISE PROTECTION	561

CHAPTER 6		LONGITUDINAL STOPS & VEHICLE EXTENSION	570
	6.1	LONGITUDINAL STOPS	571
	6.2	VEHICLE EXTENSION	573



THE COMPANY

We have been developing innovations for more than 30 years. From a modular system to a tailor-made complete solution. What began in 1986 with miniature linear guides has developed into a globally recognized full-service provider with more than 400 employees in 12 plants and more than 60 partners and service bases worldwide, as well as its own production facilities in Germany, France, Great Britain, China, Slovenia, Slovakia, Spain and the USA.

THE MODULAR SYSTEM

Our modular system and our linear technology are based on the same principle. Our designers and engineers are passionate about the principles that characterise all MiniTec products: the greatest possible simplicity, no machining, unlimited application possibilities with few components and consistent compatibility. We constantly strive to avoid senseless product diversity. Shortest assembly time, avoidance of processing and reduced storage have highest priority. We also pay special attention to ergonomic design of our components. Well-known companies worldwide use our components for equipment, automation technology and plant construction with success. In cooperation with leading research institutes, the system is constantly being further developed to meet the latest requirements. Our customers benefit from our intensive cooperation in scientific projects such as SmartFactory and the latest findings in workplace design. Future-oriented research results are thus incorporated into our development at an early stage.

COMPREHENSIVE SERVICE

Our engineers develop complete solutions for all branches of industry from our profile system. Our customers benefit from the many years of experience of our engineers. We guarantee quality and the shortest delivery time by maintaining and constantly developing all competences in our company. Expert teams for problem analysis, development and design, electrical planning, control cabinet construction, installation and commissioning ensure economical and technically mature solutions for every task of our customers. From equipment and workplace design with conveyor technology to complete production lines. Everything from a single source, without interfaces.

QUALITY

Our products are of reliable quality. All new products are thoroughly tested in our own laboratory under real operating conditions. Our quality management also subjects all existing products to the same strict tests at regular intervals. State-of-the-art machines and measuring methods guarantee consistent quality. Our quality management has been certified according to DIN EN ISO 9001 since 1996.

ENVIRONMENTAL PROTECTION

The careful use of resources and active environmental protection are among the principles of our corporate philosophy. Compliance with the environmental protection criteria is controlled in accordance with DIN EN ISO 14001 and regularly checked by external auditors. This also includes the responsible use of energy and the continuous improvement of energy efficiency.

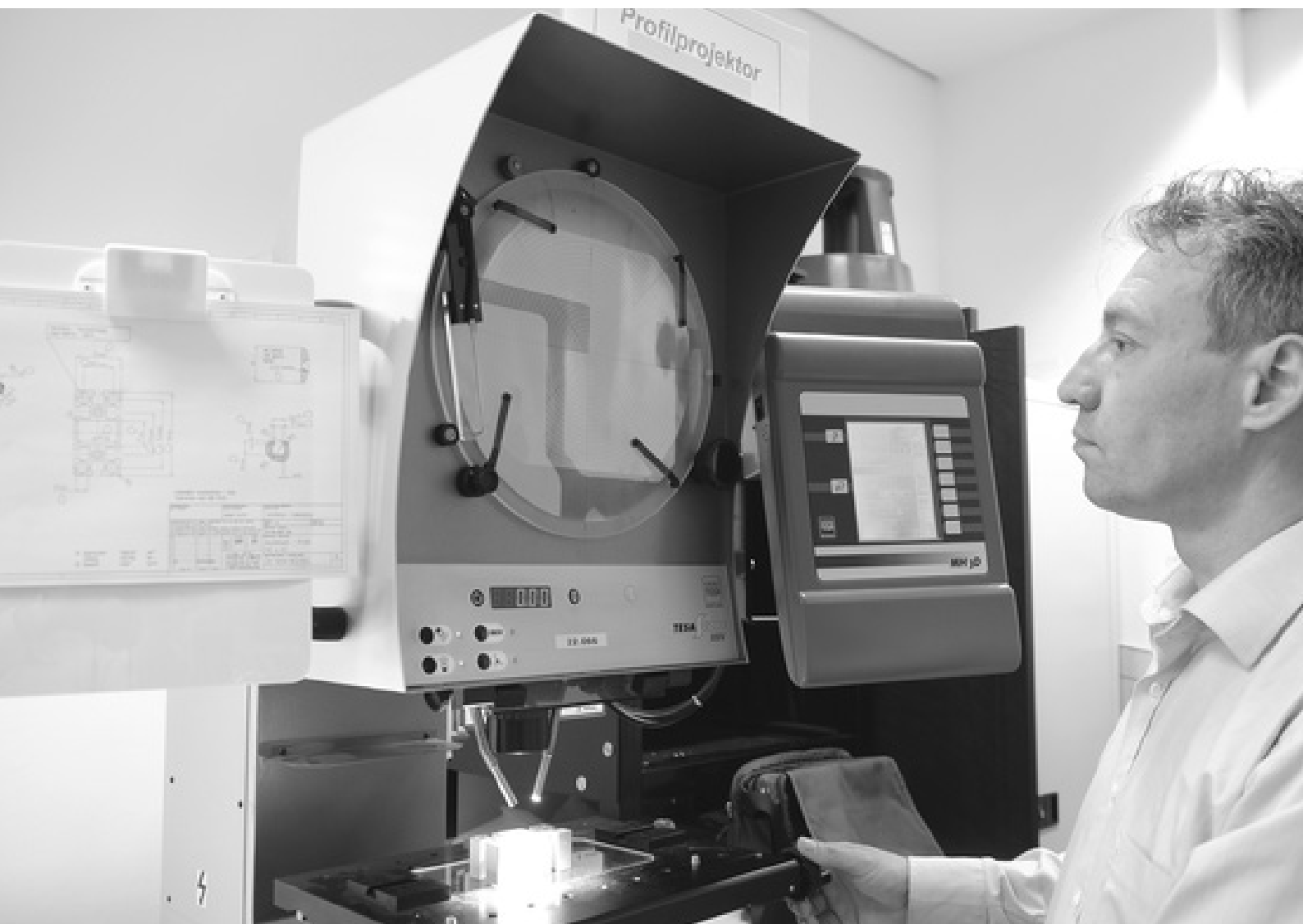

OCCUPATIONAL HEALTH AND SAFETY

Our occupational safety system complies with OHSAS 18001 (Occupational Health and Safety Assessment Series) and has been certified since 2006. These principles are also strictly observed in all designs for our customers.

CORPORATE RESPONSIBILITY

We are aware of our social responsibility. With this in mind, we create challenging jobs at our locations, provide young people with future-oriented training and offer all employees opportunities for further training. We also deliberately rely on qualified older employees and thus ensure a heterogeneous age structure of our workforce.

SECURED PROCESSES

Our organization meets the strict criteria of the and is certified according to AEOC 115021. As an authorised economic operator, our customers benefit from the associated simplifications in customs law.

CAD SUPPORT

You can download 3D CAD data for all components from our website www.minitec.de In addition, our CAD tool iCADassembler contains a complete e-catalogue with CAD data.



customs simplifications



Our CAD tools are the logical complement to our modular hardware. All requirements of planning and execution are comprehensively considered. The combination of components and software unlocks the full potential for rational, flexible and modern mechanical engineering. iCADassembler is a CAD tool of the latest generation, which we make available to our customers free of charge. The tool contains electronic catalogs,

automatic parts lists and configurators for common applications such as ergonomic workstations, linear axes, conveyor belts, roller conveyors or protective devices. iCADassembler reduces design time by at least 60%, while reliably avoiding errors.

Benefit from the functionality of iCADassembler!

ADVANTAGES

- System independent 3D design tool for MiniTec components
- Time saving for the user of approx. 60 percent
- Planning and design of components and systems independent of CAD software
- CAD functionality without own CAD software
- Easy to operate with special anchors, line snap points and drag & drop
- Direct interfaces to all common CAD systems such as: Mechanical Desktop, ProEngineer, Solid Works, Solid-Edge, MegaCAD and more.
- More than 180 data output formats in 2D and 3D
- Automated design module for: Linear axes, sliding guides, conveyor belts, workstations
- Automatic creation of parts lists
- Integrated plausibility check
- Automatic machining drawings

By popular request MiniTec offers regular iCAD Assembler training courses. In one-day seminars we teach the time-saving features of this powerful tool with practical exercises. The courses are led by our experienced technicians and take place on individually agreed dates.

TECHNICAL DATA

ALUMINIUM PROFILE

Aluminium alloy by DIN EN 573-3		
Material	EN AW-Al Mg0,7Si status T66	EN-AW-6063 T66
	Specific weight	2,75 g / cm ³
	Material-N°	3.3206.72 (artificially aged)
	Tenacity	min. Rm = 245 N / mm ²
	0,2 % twist boundary	min. Rp 0,2 = 200 N / mm ²
	Ductile yield A 5	> 10%
	Ductile yield A 10	> 8%
	Modulus of elasticity	E: 70000 N / mm ²
	Hear modulus	G: 27000 N / mm ²
	Expansion hardness	ca. 75 HB 2,5 / 187,5
Heat extension	23.8 · 10 - 6K-1	

Anodizing by DIN 17611		
SURFACE	Eloxal E6/EV1, natur anodized, or EURAS C0	
	Layer thickness	ca. 10 - 15 µm
	Layer hardness	250 - 350 HV
TOLERANCES	Aluminium extruded profile	DIN EN 12020 T 1 + 2
	Outer dimensions	0,2 to 0,4 mm
	Straightness deviatin	max. 1,5 mm / 2 m
Generally we confirm half the values according to the tolerances of DIN EN 12020 part 2.		

Blanks	ISO 2768-m
Angle + Length	Usually half values of ISO 2768 m

PROFILE SERIES / BASIC GRID	Profile serie	30	45
	Core boring	7,5 - 0,3	
	Standard thread	M8	

All profiles of the individual profile series are developed from the same grid. The tread grooves are uniform. All profiles can be combined with each other.

The M8 thread is formed with non-cutting thread formers. (It can be drilled up to M12)

TECHNICAL DATA

SST-PROFILES

MATERIAL

X5 Cr Ni 18-10	stainless steel, DIN EN 10 088
Specific weight	7,9 g / cm ³
Material-N°	1.4301 (cold rolled)
Tenacity	min. Rm = 540 N / mm ²
0,2 % twist boundary	min. Rp0,2 = 230 N / mm ²
Ductile yield	> 35%
Modulus of elasticity	E: 200 000 N / mm ²
Hear modulus	G: 80 000 N / mm ²
Hardiness Vickers	220 - 260 HV
Heat extension	11,5 · 10 ⁻⁶ K ⁻¹

TOLERANCE

	DIN ISO 2768 - c
Outer dimensions	± 0,3 mm
Straightness deviatin	0,001 x L

Generally we confirm half the values of the permissible tolerances.

Blanks	ISO 2768-m
Angle + Length	Usually half values of ISO 2768 m

CORE BORING

Uniform 7,5 - 0,6 mm

Thread M8 is made with a tap

GRID

Basic grid 45 mm

Due to its identical groove the profile 45 x 45 SST is fully compatible with the aluminium profile system

TECHNICAL DATA

PROFILE SERIES 30

GROOVES

One system for profiles 16 to 60 mm.
The grooves are identical for all profiles. Groove width: 8,5 - 0,3 mm

BASIC DIMENSIONS

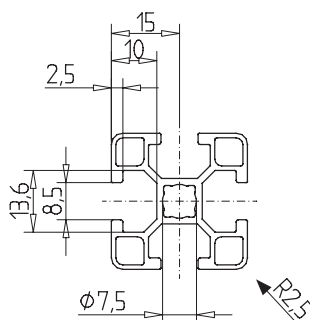

LOAD CAPACITY

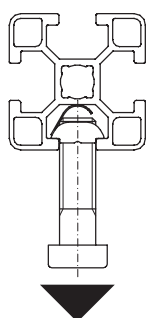

$F = 2600 \text{ N}$

USABLE SCREWS AND NUTS

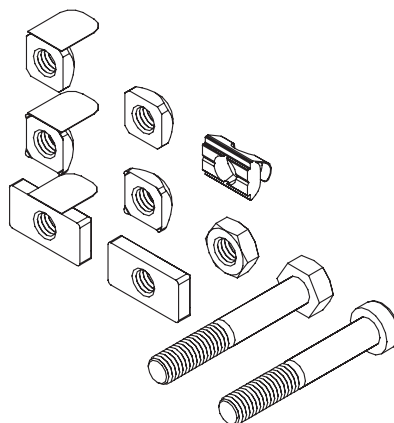

TECHNICAL DATA

PROFILE SERIES 45

GROOVES

One system for profiles from 19 to 270 mm. The grooves are identical in all profiles. Groove width: 8.5 - 0.3 mm. The grooves are designed to accept DIN M8 screws with 13 mm head diameter and 13 mm outer nuts. Square and hexagon nuts and screws are secured against rotation

BASIC DIMENSIONS

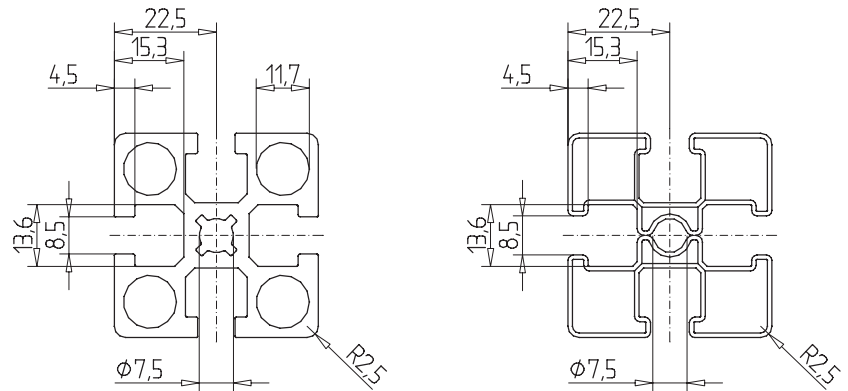

LOAD CAPACITY

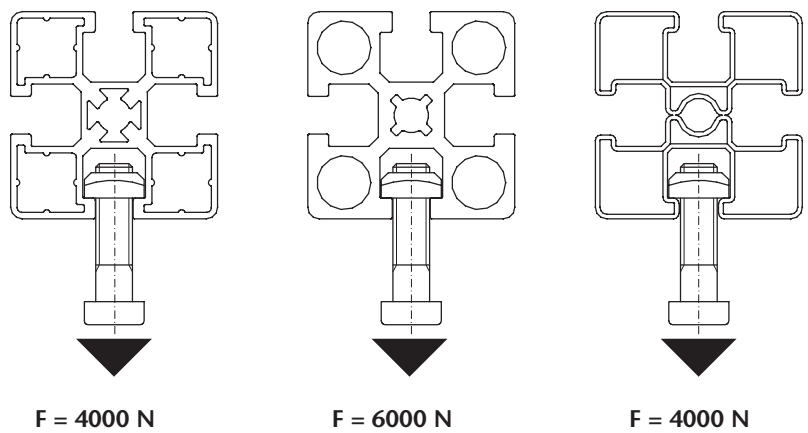

USABLE SCREWS AND NUTS

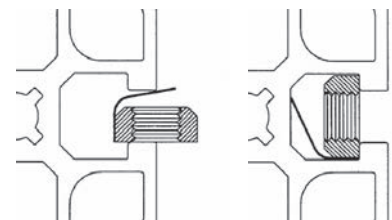
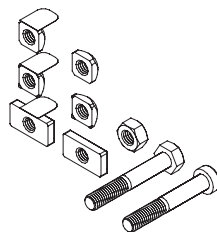

Sliding nuts can be swiveld in at any point of the profil.

TECHNICAL DATA

CALCULATION OF THE DEFLECTION OF MINITEC ALUMINIUM PROFILES

Deflection f (mm), calculated for static load in form of a point as shown below

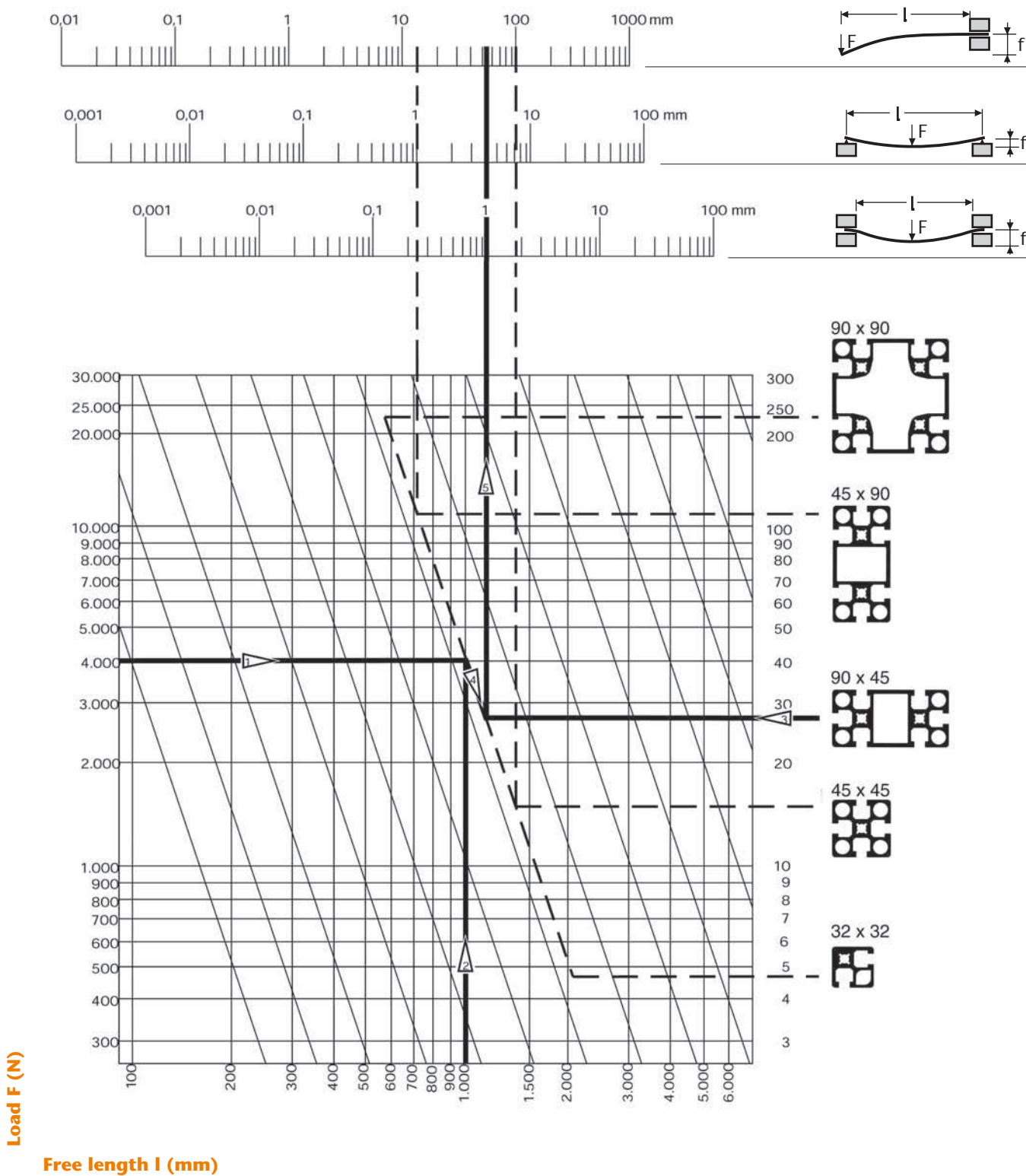

Geometrical moment of inertia I (cm⁴)

The following formulas and examples of calculation are for static load in the form of a point..
 For the determination of other load, please use the equations in the relevant literature. In particular we want to point out that reduced values should be used for dynamic loads.

CALCULATION OF DEFLECTION OF MINITEC PROFILES

EXAMPLE

- f = Deflection [mm]
- F = Load [N]
- L = Free length [mm]
- I = Geometrical moment of inertia [cm⁴]
- E = Modulus of elasticity: Aluminum 70 000 N / mm²
 Steel 200 000 N / mm²

EXAMPLE 1



EXAMPLE 2

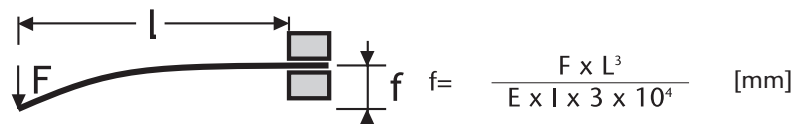

EXAMPLE 3

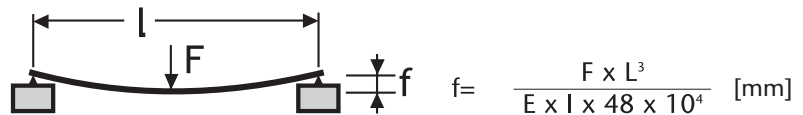

The above mentioned equations are easy to calculate using the diagram on the previous page.
 Follow the steps in the given row for the respective value.

Deflection (f)	1	2	3	4	5
Max. load (F)	3	5	2	4	1
Profile determination (section)	1	2	5	4	3
Free length (L)	3	5	1	4	2

TECHNICAL DATA

Calculate deflection via app



With the MiniTec App, designers, equipment manufacturers and production planners can easily calculate the load-dependent deflection of the aluminium profiles and linear axes from MiniTec’s modular system using their smartphone. This makes it easy to determine whether the profiles and axes of the static and point load are dimensioned correctly in the specific case. To determine the deflection, the app calculates the three most common load cases on the basis of a few entries: For vertical loading of a profile clamped on one side (outrigger), for a central vertical loading on a profile resting on both sides, and for a central vertical loading on a profile clamped on both sides. The calculation program of the MiniTec app immediately shows the user whether the profile or the built-in axis used was selected correctly for the application or whether the deflection is above the permissible limit values - and therefore a stronger component from the current MiniTec modular system is the better choice.

With the new calculation app for all smartphones with iOS or Android operating systems, MiniTec not only simplifies the work of planners and equipment manufacturers, but also makes a directly realisable contribution to safety at the workplace.

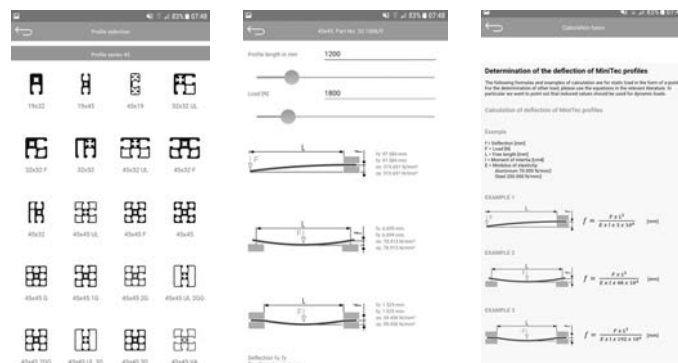

	1.1	ALUMINIUM PROFILE	15
	1.2	FASTENING ELEMENTS	64
	1.3	HINGES & JOINTS	104
	1.4	HANDLES, LOCKS, STOPS	120
	1.5	FEET, CASTORS, FLOOR FASTENINGS, SUPPORTS	147
	1.6	FITTING OF SURFACE ELEMENTS & INSTALLATION OPTIONS	174
	1.7	EDGE, COVER, SLIDE AND SEALING PROFILES	194
	1.8	PRE-ASSEMBLED ELEMENTS FOR LIFTING AND SLIDING DOORS	211
	1.9	ELECTRICAL INSTALLATION	232
	1.10	DRIVE UNITS AND CONTROL SYSTEMS	248
	1.11	PNEUMATICS	255
	1.12	HYDRAULICS	261

PROFILE SECTIONS - PROFILE SERIES 30

PROFILE SERIES 30



23 x 16
20.1115/0



16 x 30
20.0983/0



23 x 23
20.1116/0

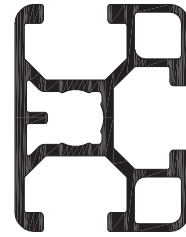

23 x 30
20.1117/0

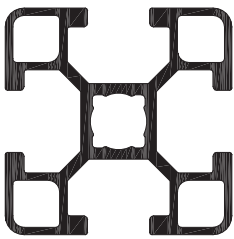

30 x 30
20.1068/0

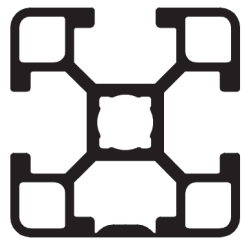

30 x 30 1G
20.1139/0

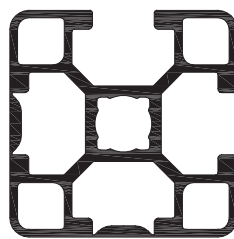

30 x 30 2G
20.1124/0

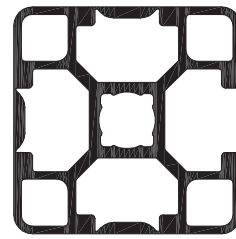

30 x 30 3G
20.1085/0

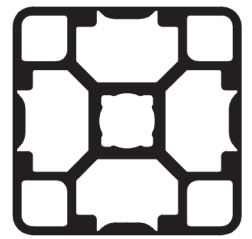

30 x 30 G
20.1141/0

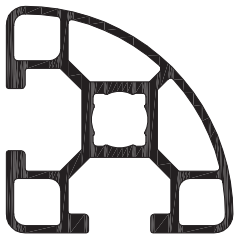

30 R 90°
20.1125/0



30 R 60°
20.1136/0



30 R 45°
20.1135/0



30 R 30°
20.1134/0

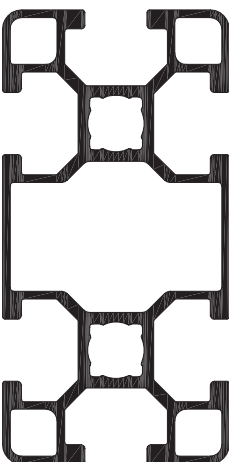

30 x 60
20.0994/0

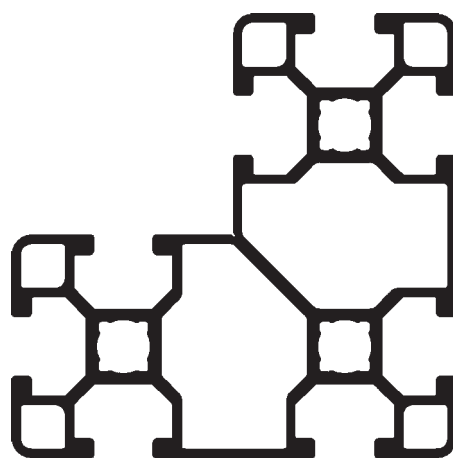

60 x 60 x 30
20.0982/0

PROFILE SECTIONS - PROFILE SERIES 45

PROFILE SERIES 45

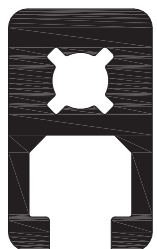

19 x 32
20.1000/0



32 x 32 UL
20.1064/0



32 x 32 F
20.1054/0

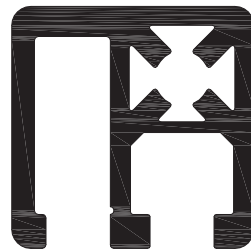

Clamping profile
32 x 32
20.1070/0

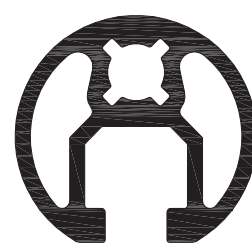

Handle profile 32
20.1088/0

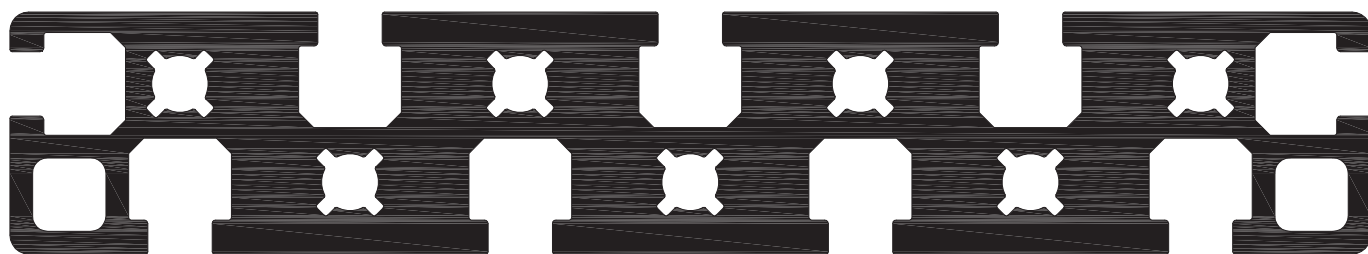

32 x 180
20.1016/0



19 x 19 S
20.1073/0



19 x 45
20.1001/0

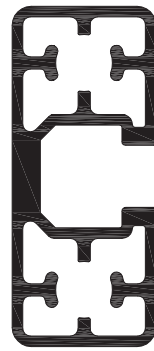

45 x 19
20.0993/0

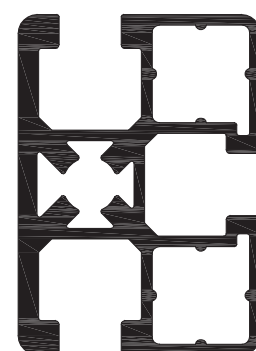

45 x 32 UL
20.1065/0



Clamp profile 45 x 45 F
20.1147/0

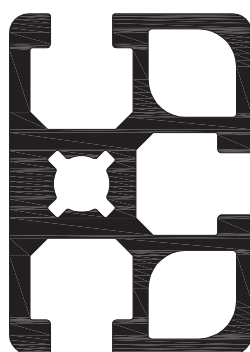

45 x 32 F
20.105a5/0



Clamping profile
45 x 32
20.1053/0

PROFILE SECTIONS - PROFILE SERIES 45

PROFILE SERIES 45

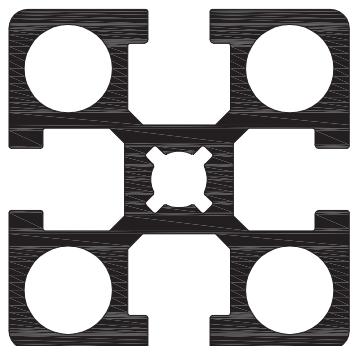

45 X 45
20.1006/0

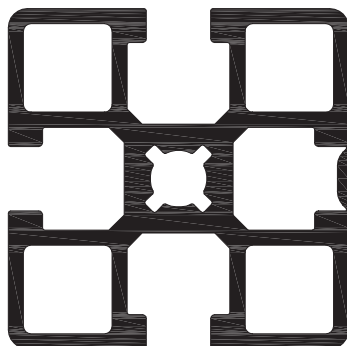

45 x 45 1G
20.1126/0

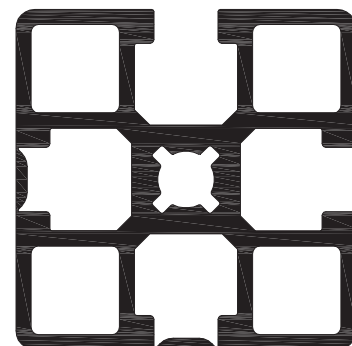

45 x 45 2G
20.1072/0

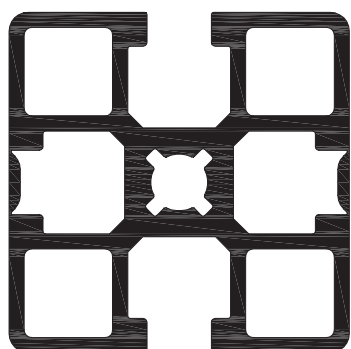

45 x 45 2GG
20.1099/0

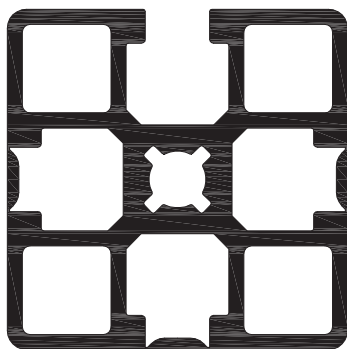

45 x 45 3G
20.1048/0

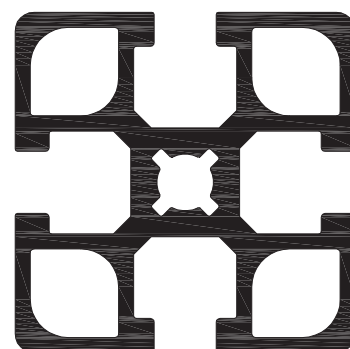

45 x 45 F
20.1033/0

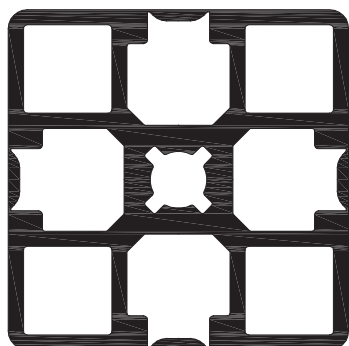

45 x 45 G
20.1028/0

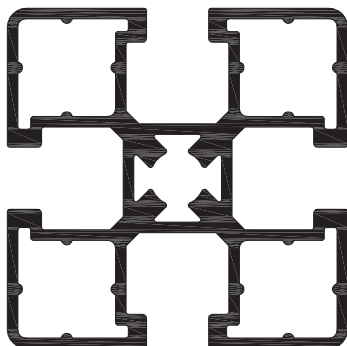

45 x 45 UL
20.1063/0

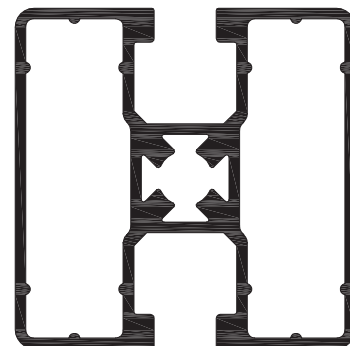

45 x 45 UL 2GG
20.1122/0

PROFILE SECTIONS - PROFILE SERIES 45

PROFILE SERIES 45

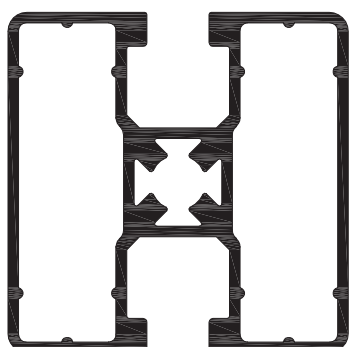

45 x 45 UL 2GG
20.1122/0

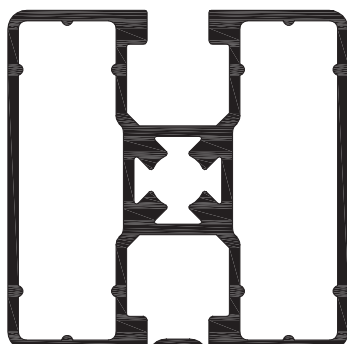

45 x 45 UL 3G
20.1123/0

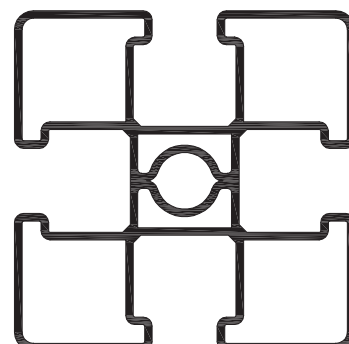

45 x 45 VA
20.2000/0

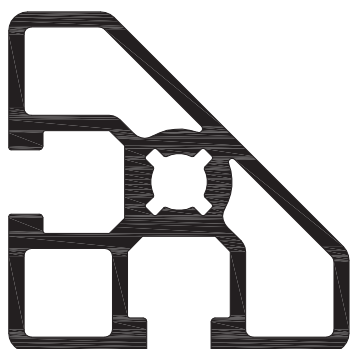

45 / 45°
20.1029/0

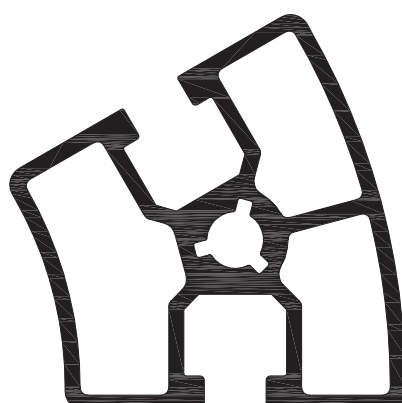

45 R 30°
20.1094/0

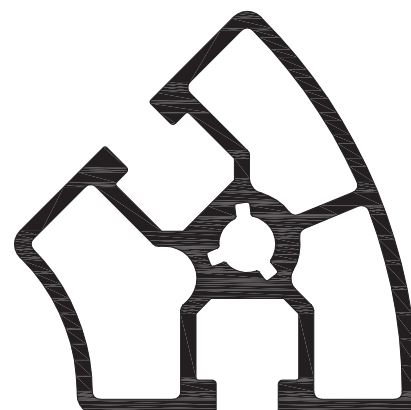

45 R 45°
20.1095/0

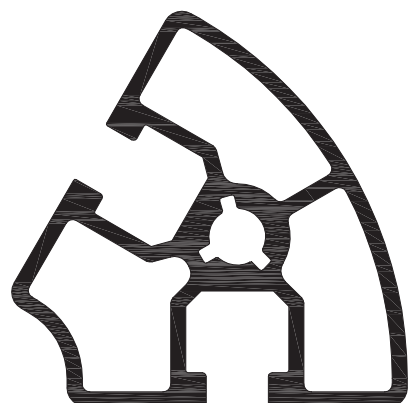

45 R 60°
20.1096/0

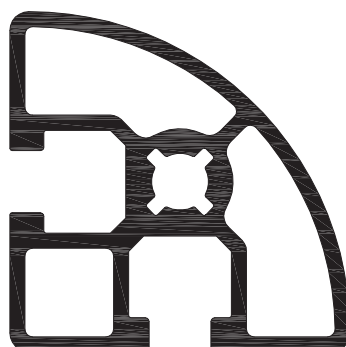

45 R 90°
20.1069/0

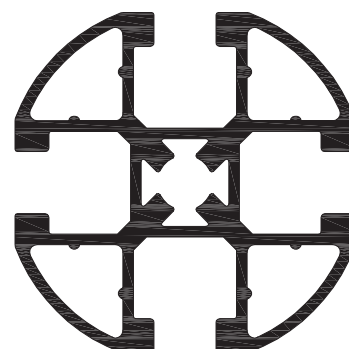

45 R4
20.1120/0

PROFILE SECTIONS - PROFILE SERIES 45

PROFILE SERIES 45

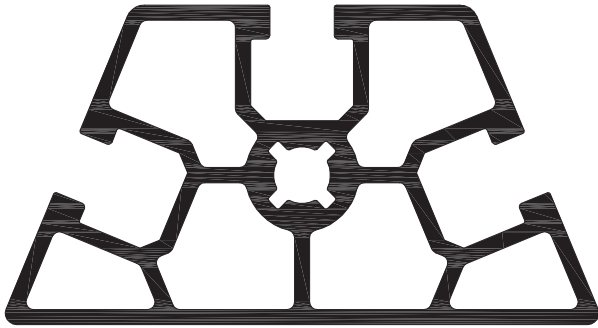

45 / 22,5°
20.1030/0

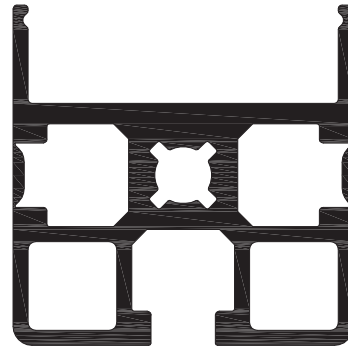

45 x 45 R
20.1046/0

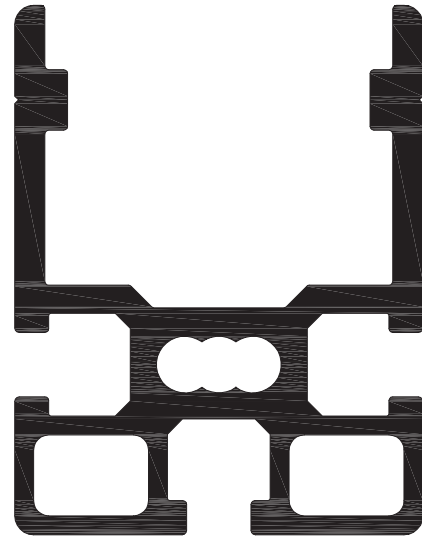

Profile height adjustment
20.1143/0

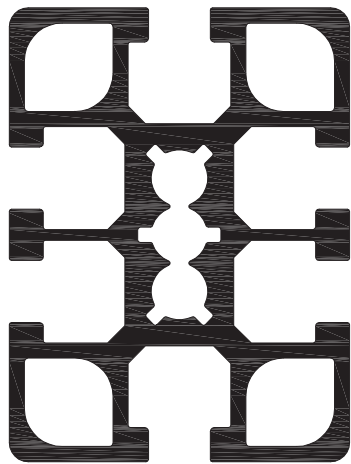

45 x 60 F
20.1023/0

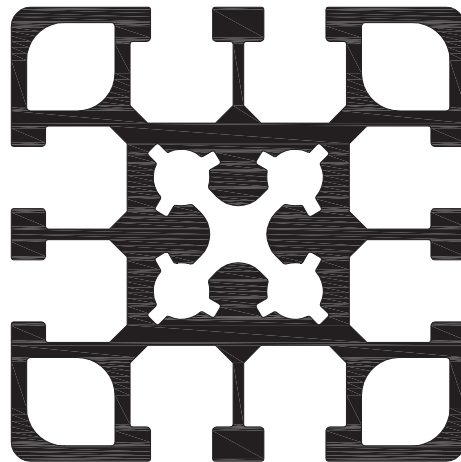

60 x 60 F
20.1049/0

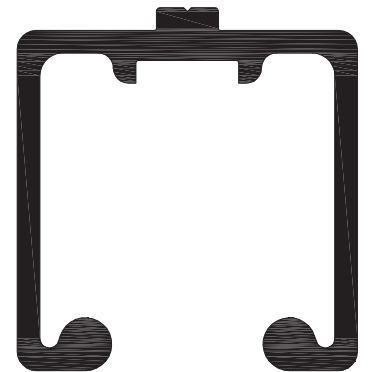

Guide rail profile
20.1038/0

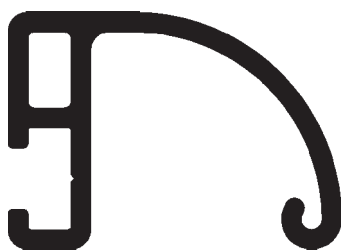

Handle profile
20.1045/0

PROFILE SECTIONS - PROFILE SERIES 45

PROFILE SERIES 45

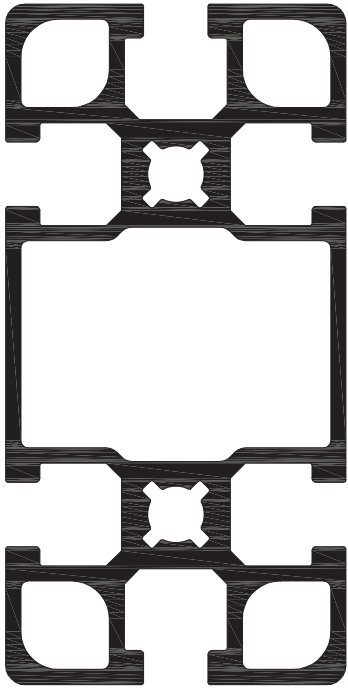

45 x 90 F
20.1032/0

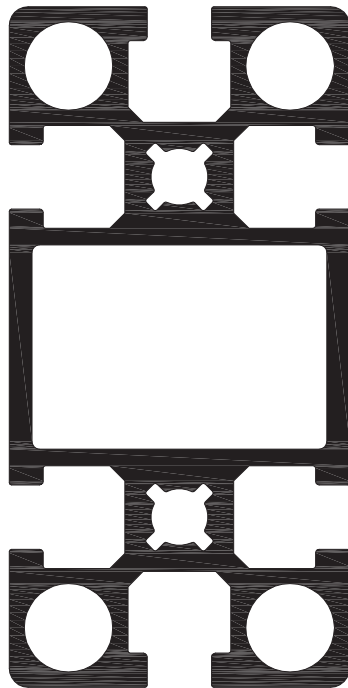

45 x 90
20.1009/0

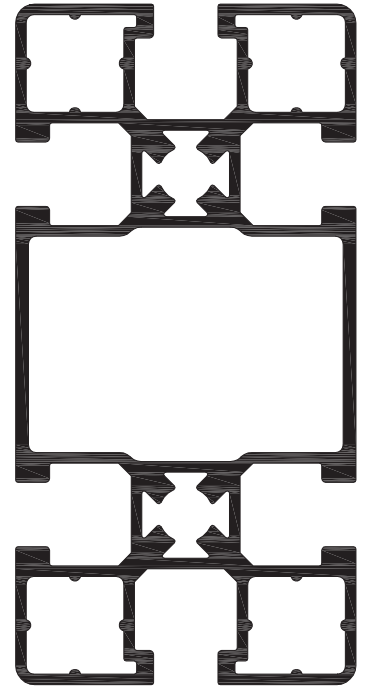

45 x 90 UL
20.1067/0

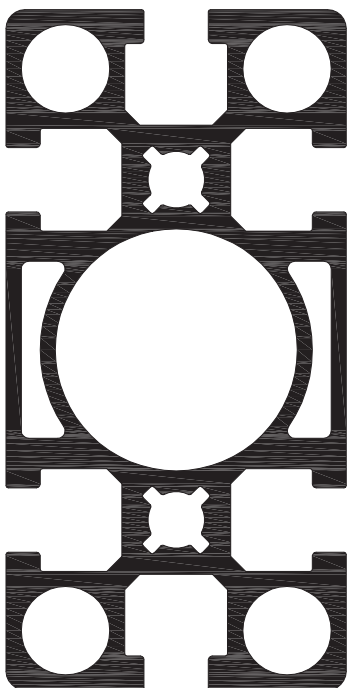

45 x 90 S
20.1017/0

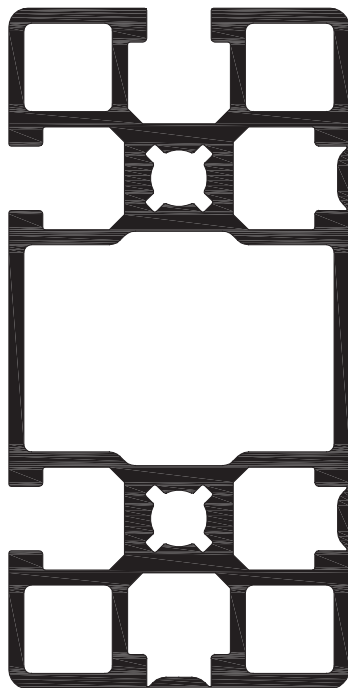

45 x 90 2G
20.1081/0

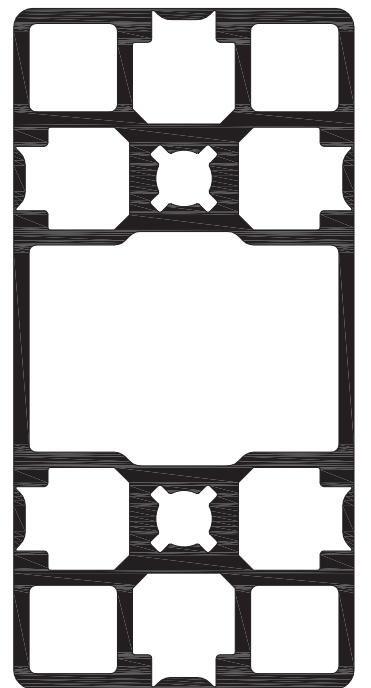

45 x 90 G
20.1015/0

PROFILE SECTIONS - PROFILE SERIES 45

PROFILE SERIES 45

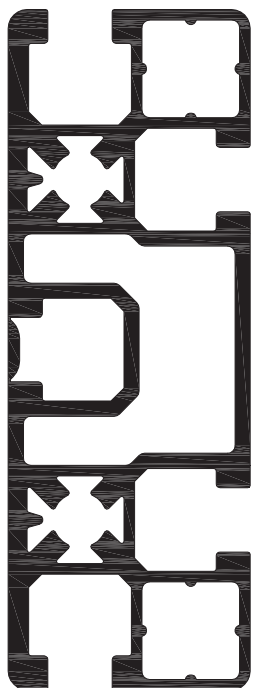

90 x 32 UL
20.1066/0

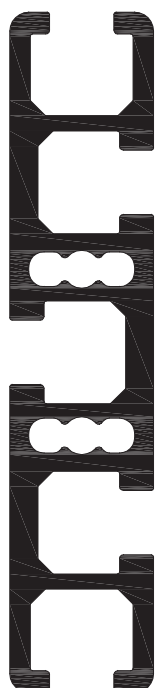

19 x 90
20.0995/0

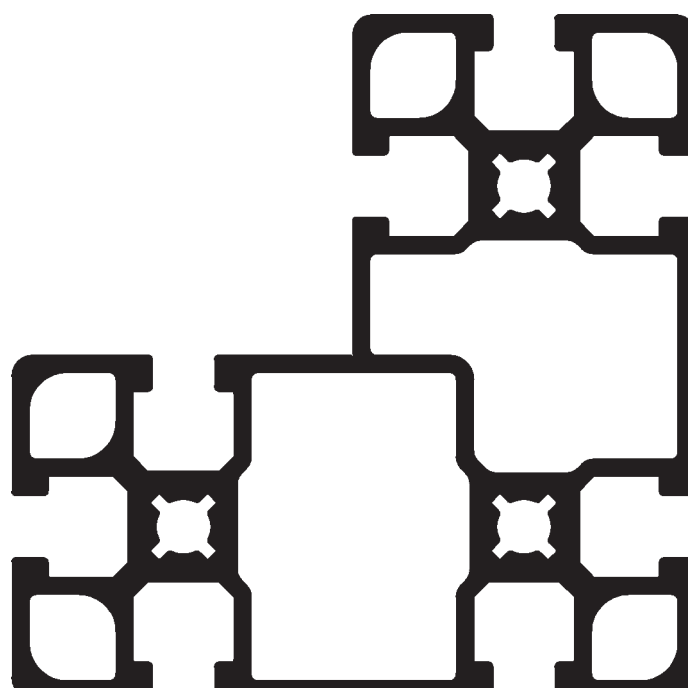

90 x 90 x 45
20.0984/0

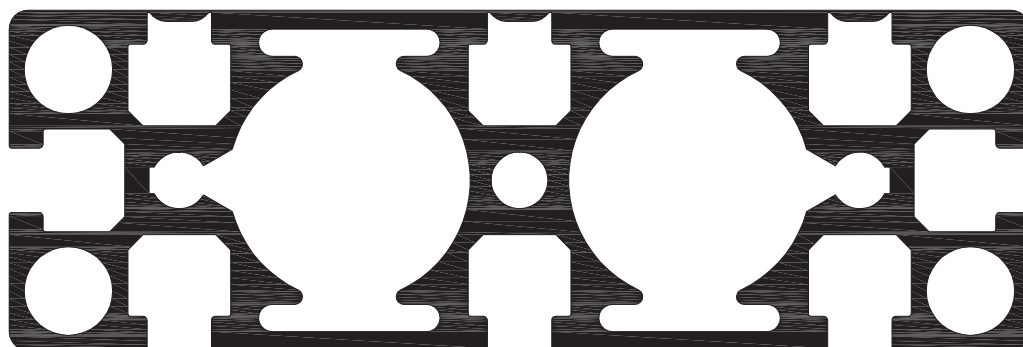

45 x 135 1G
20.1078/0

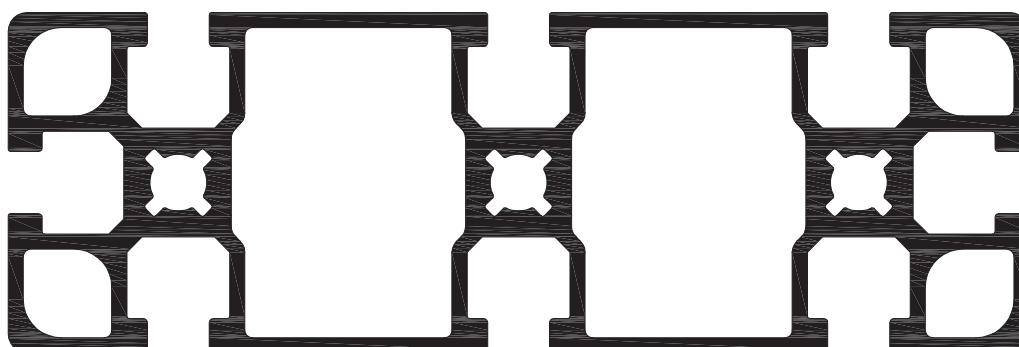

45 x 135 F
20.1087/0

PROFILE SECTIONS - PROFILE SERIES 45

PROFILE SERIES 45

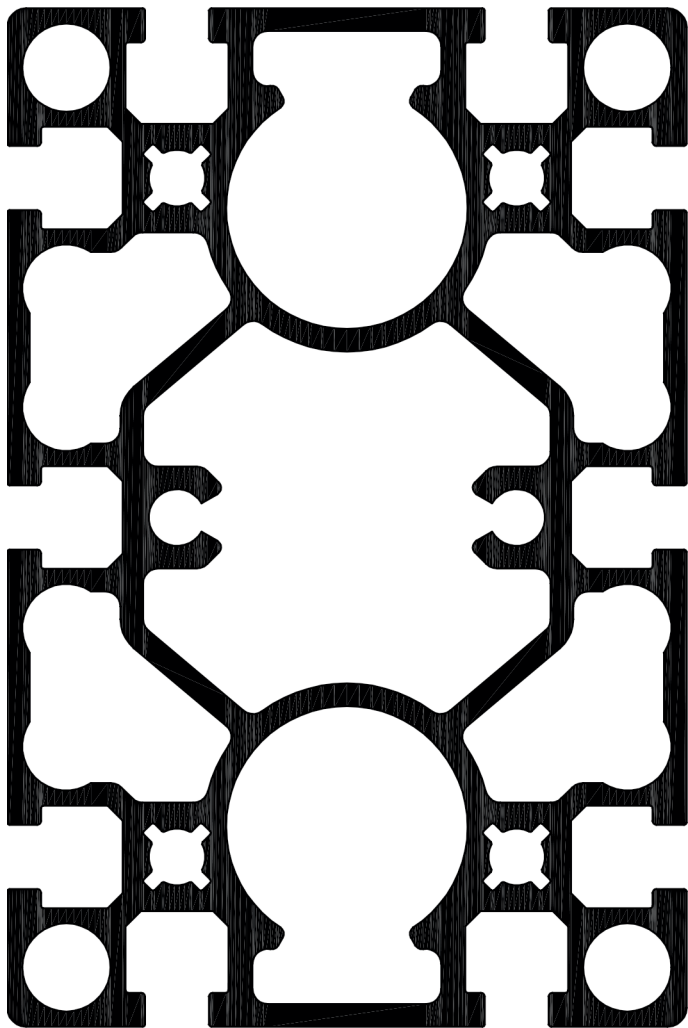

90 x 135
20.1148/0

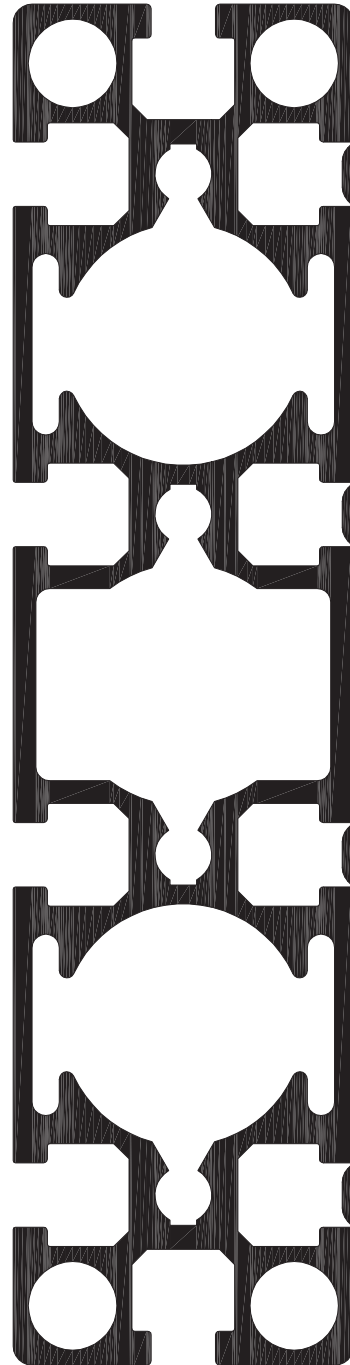

45 x 180 1G
20.1079/0



270 x 19
20.1077/0

PROFILE SECTIONS - PROFILE SERIES 45

PROFILE SERIES 45

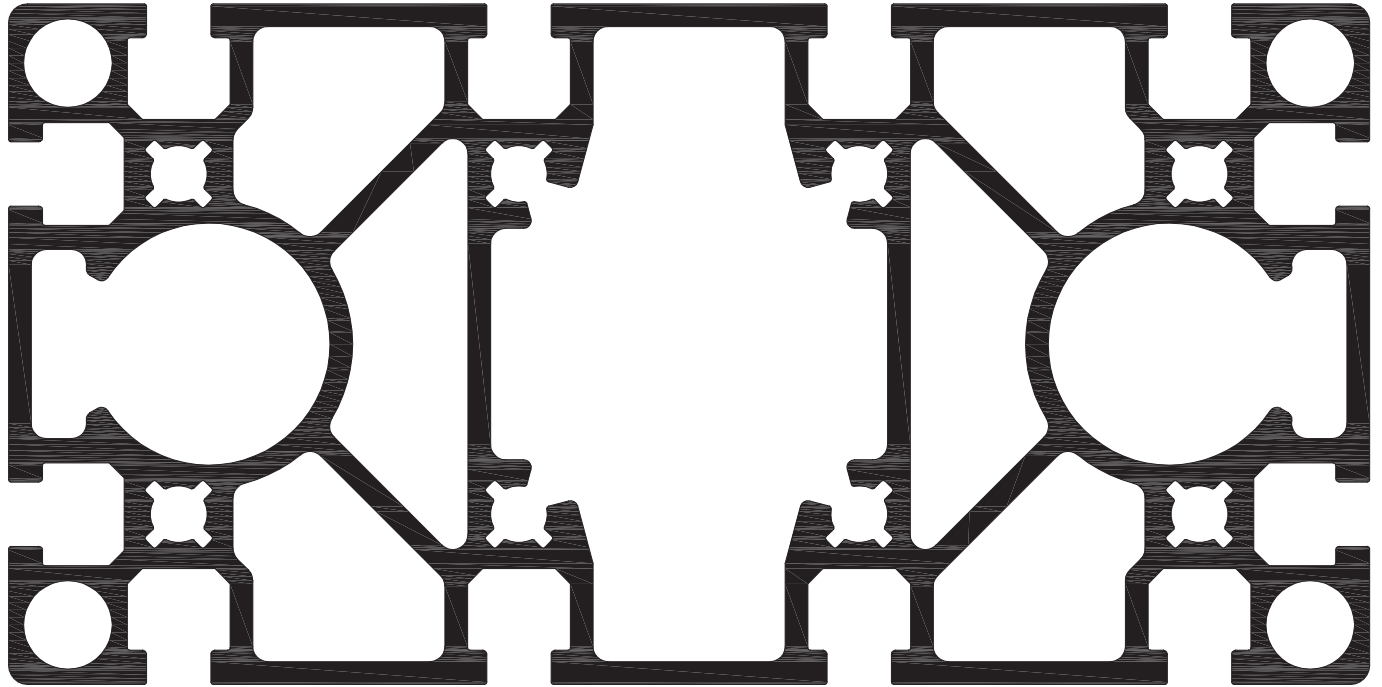

90 x 180
20.1013/0

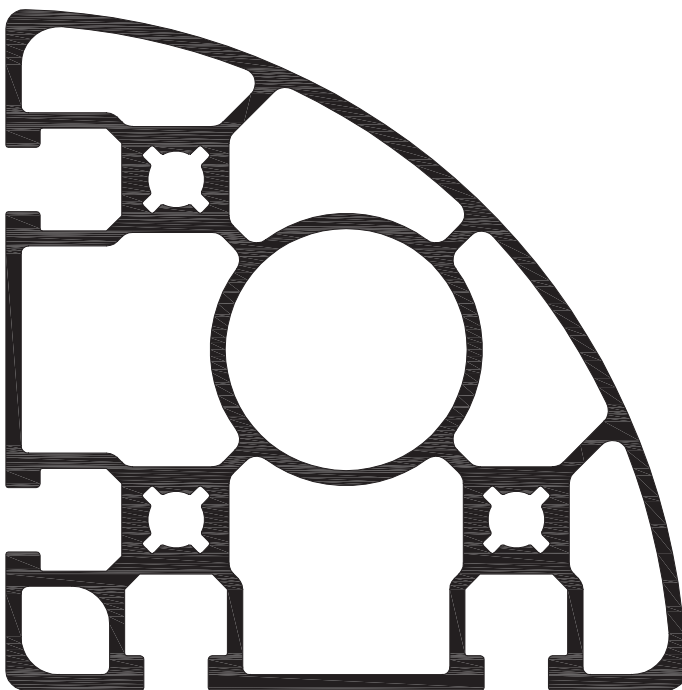

90 R 90°
20.1091/0

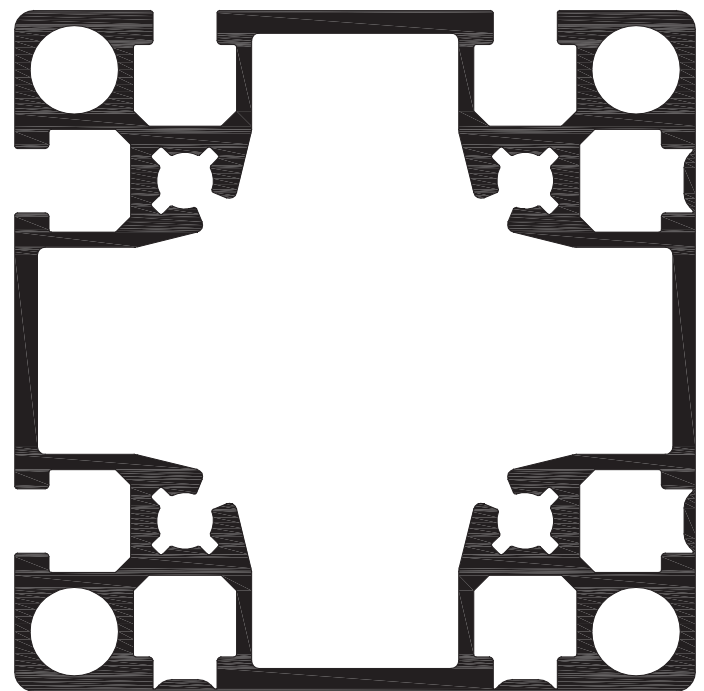

90 x 90 2G
20.1044/0

PROFILE SECTIONS - PROFILE SERIES 45

PROFILE SERIES 45

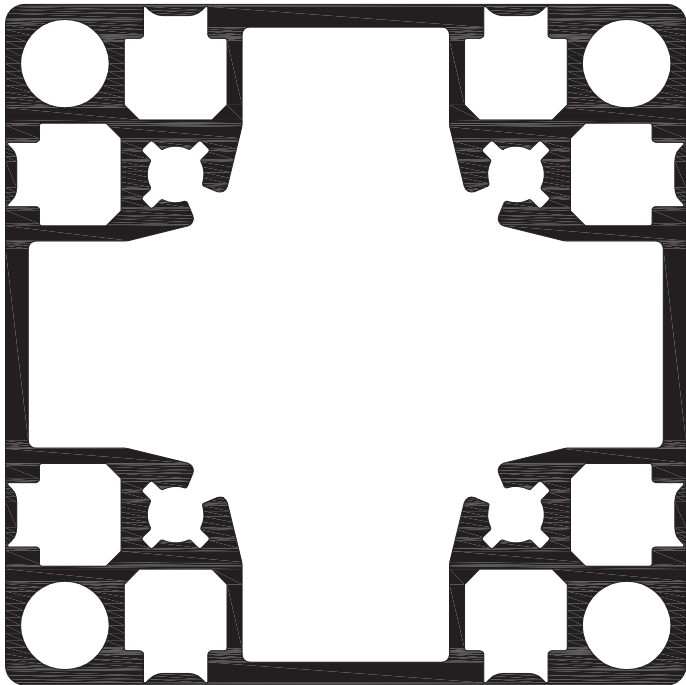

90 x 90 G
20.1082/0

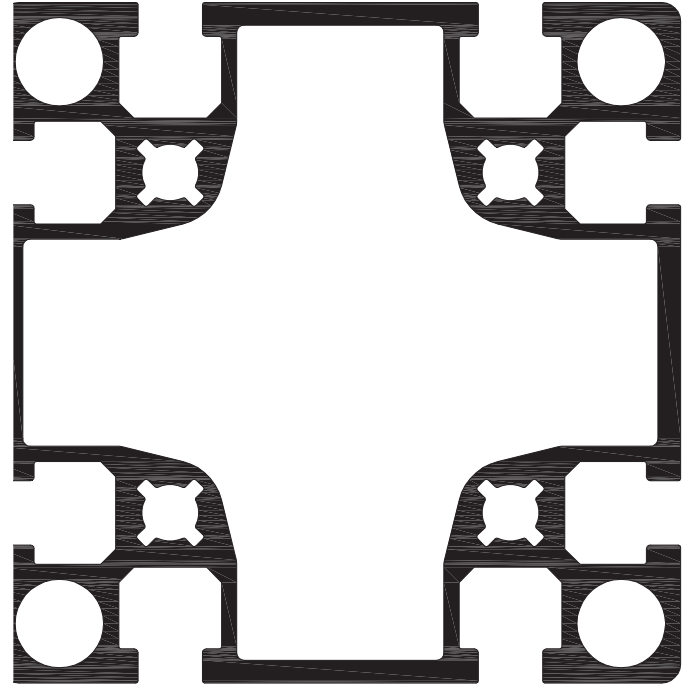

90 x 90 L
20.1010/0

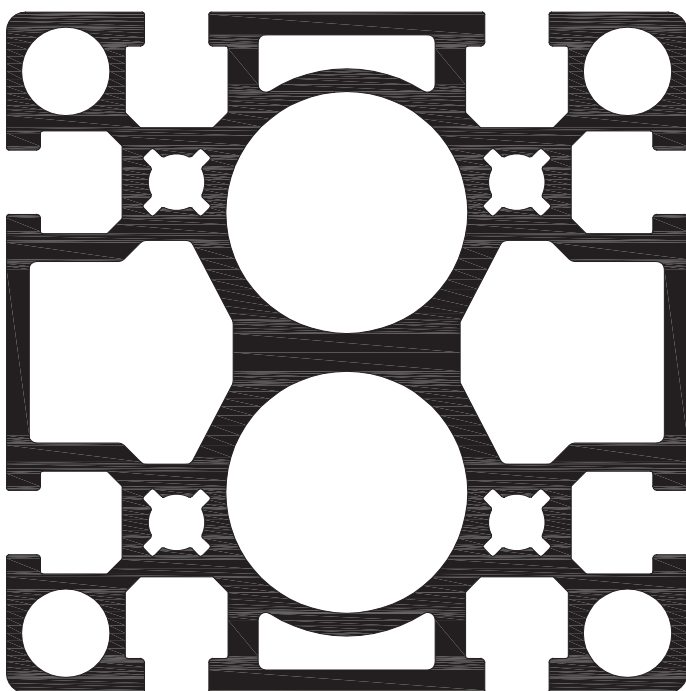

90 x 90 S
20.1019/0

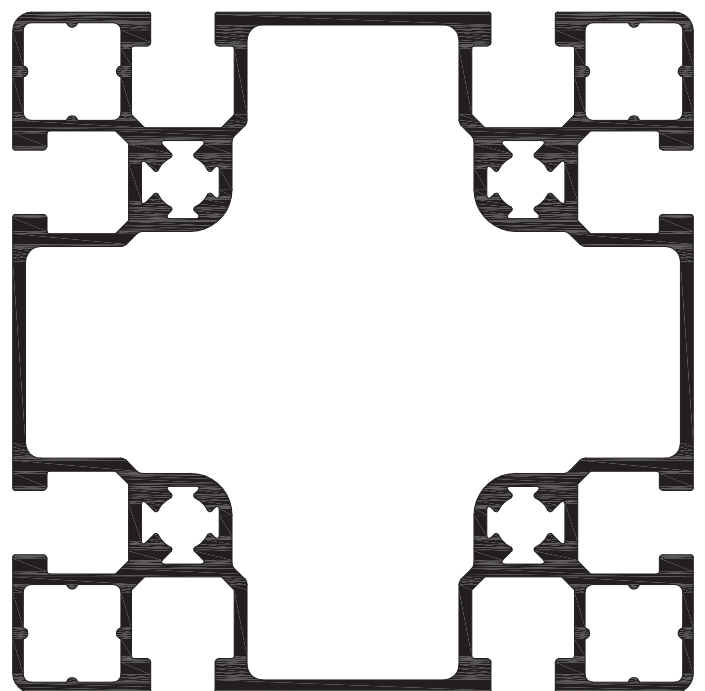

90 x 90 UL
20.0999/0

PROFILE 23 X 16

Part no.

20.1115/0

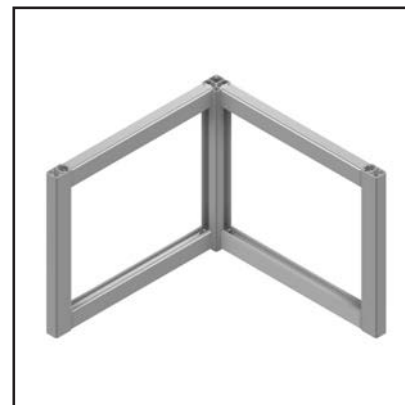
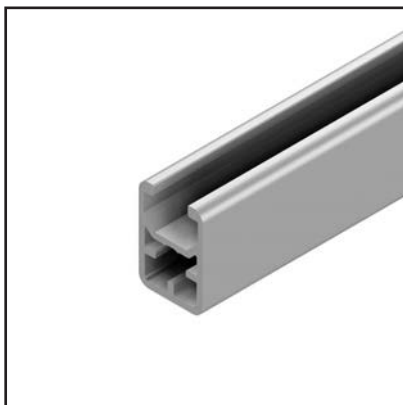
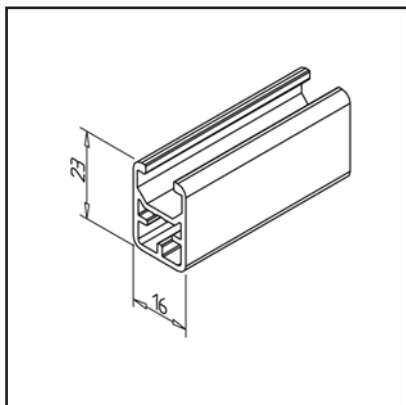
**TECHN. DATA / ITEMS SUPPLIED**

- Aluminium, extruded, anodized E6/EV1
- $I_x = 0.602 \text{ cm}^4$
- $I_y = 0.442 \text{ cm}^4$
- $w_x = 0.472 \text{ cm}^3$
- $w_y = 0.552 \text{ cm}^3$
- Weight = 0.341 kg/m
- Bar length = 6 m
- Packing unit = 72 m

APPLICATIONS

- Light constructions with protective hoods, covers, etc.

ASSEMBLY

- Power-lock fastener 30 / N 30
- Mitre connector 30
- Screw connection 30
- Angle 16
- Attaching accessories with sliding nut 30 M4 / M5 / M6 / M8

PROFILE 16 X 30

Part no.

20.0983/0

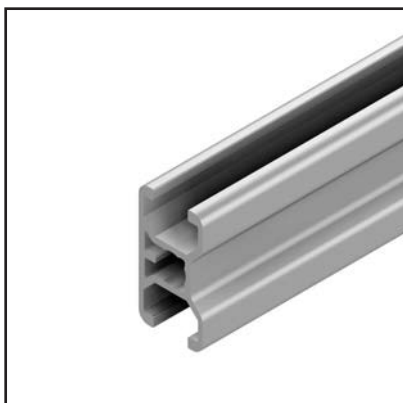
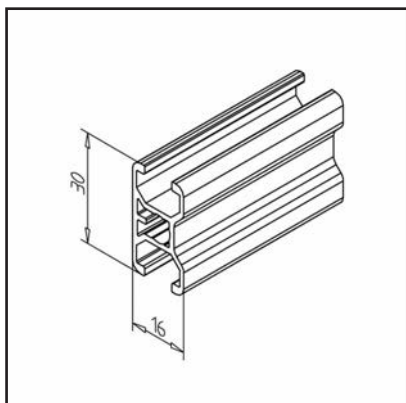
**TECHN. DATA / ITEMS SUPPLIED**

- Aluminium, extruded, anodized E6/EV1
- $I_x = 1.008 \text{ cm}^4$
- $I_y = 0.479 \text{ cm}^4$
- $w_x = 0.672 \text{ cm}^3$
- $w_y = 0.544 \text{ cm}^3$
- Weight = 0.382 kg/m
- Bar length = 6 m
- Packing unit = 72 m

APPLICATIONS

- Light constructions with protective hoods, covers, etc.

ASSEMBLY

- Power-lock fastener 30 / N 30
- Mitre connector 30
- Screw connection 30
- Angle 16
- Attaching accessories with sliding nut 30 M4 / M5 / M6 / M8

PROFILE 23 X 23

Part no.

20.1116/0

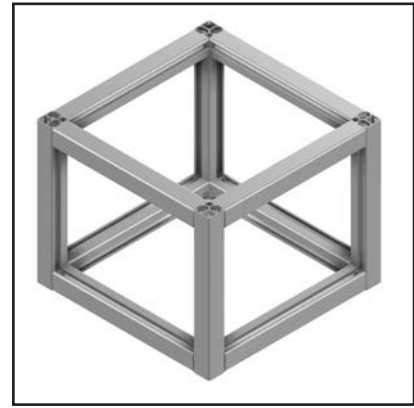
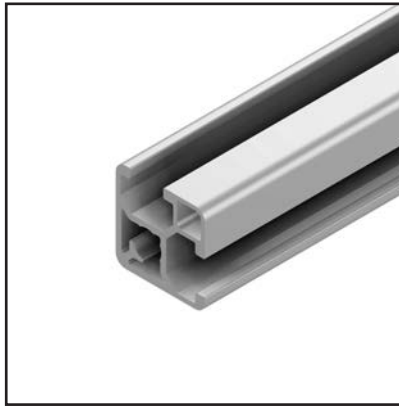
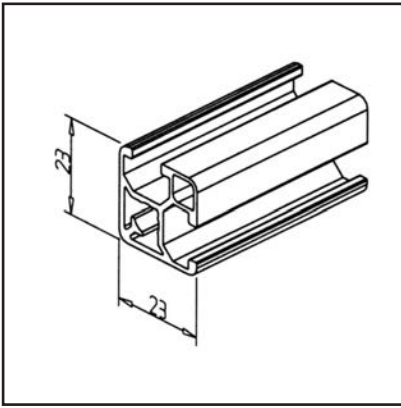

TECHN. DATA / ITEMS SUPPLIED

- Aluminium, extruded, anodized E6/EV1
- $I_x = 0.921 \text{ cm}^4$
- $I_y = 0.921 \text{ cm}^4$
- $w_x = 0.729 \text{ cm}^3$
- $w_y = 0.729 \text{ cm}^3$
- Weight = 0.443 kg/m
- Bar length = 6 m
- Packing unit = 72 m

APPLICATIONS

- Light constructions with protective hoods, covers, etc.

ASSEMBLY

- Power-lock fastener 30 / N 30
- Mitre connector 30
- Screw connection 30
- Angle 16
- Attaching accessories with sliding nut 30 M4 / M5 / M6 / M8

PROFILE 23 X 30

Part no.

20.1117/0

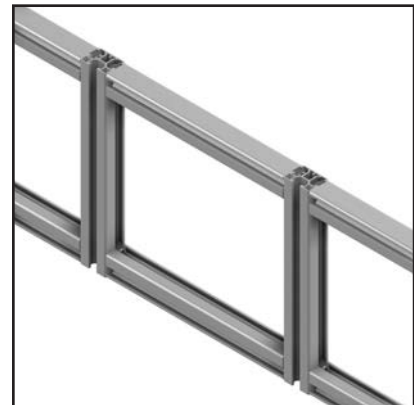
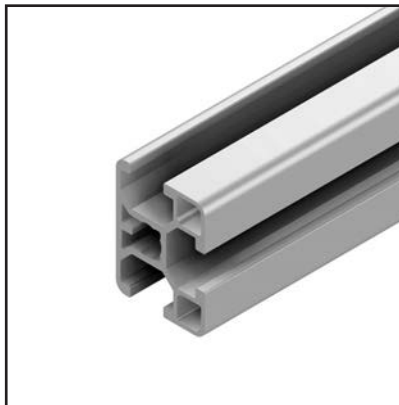
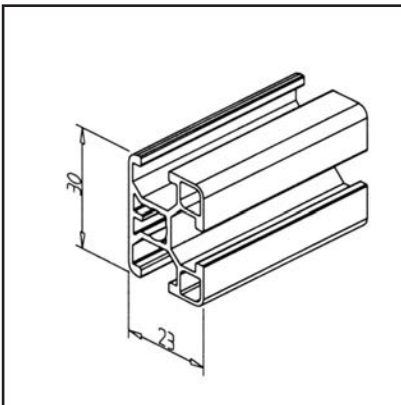

TECHN. DATA / ITEMS SUPPLIED

- Aluminium, extruded, anodized E6/EV1
- $I_x = 1.565 \text{ cm}^4$
- $I_y = 1.187 \text{ cm}^4$
- $w_x = 1.043 \text{ cm}^3$
- $w_y = 0.975 \text{ cm}^3$
- Weight = 0.524 kg/m
- Bar length = 6 m
- Packing unit = 72 m

APPLICATIONS

- Light constructions with protective hoods, covers, etc.

ASSEMBLY

- Power-lock fastener 30 / N 30
- Mitre connector 30
- Screw connection 30
- Angle 16 / 30
- Attaching accessories with sliding nut 30 M4 / M5 / M6 / M8

PROFILE 30 X 30

Part no.

20.1068/0

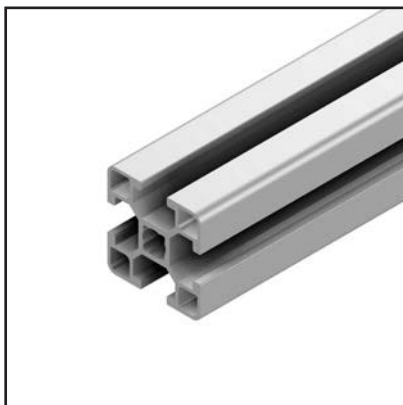
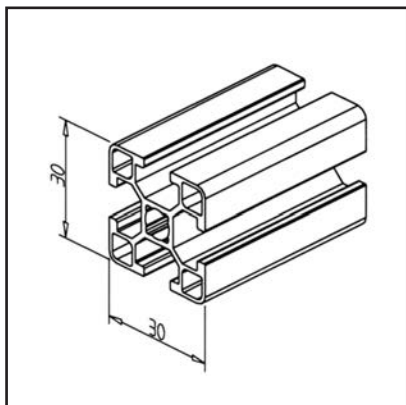
**TECHN. DATA / ITEMS SUPPLIED**

- Aluminium, extruded, anodized E6/EV1
- $I_x = 2.133 \text{ cm}^4$
- $I_y = 2.133 \text{ cm}^4$
- $w_x = 1.422 \text{ cm}^3$
- $w_y = 1.422 \text{ cm}^3$
- Weight = 0.652 kg/m
- Bar length = 6 m
- Packing unit = 54 m

APPLICATIONS

- Light constructions with protective hoods, covers, etc.

ASSEMBLY

- Power-lock fastener 30 / N 30
- Mitre connector 30
- Screw connection 30
- Angle 16 / 30
- Attaching accessories with sliding nut 30 M4 / M5 / M6 / M8

PROFILE 30 X 30 G

Part no.

20.1141/0

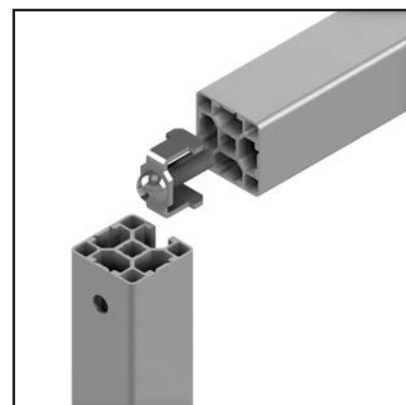
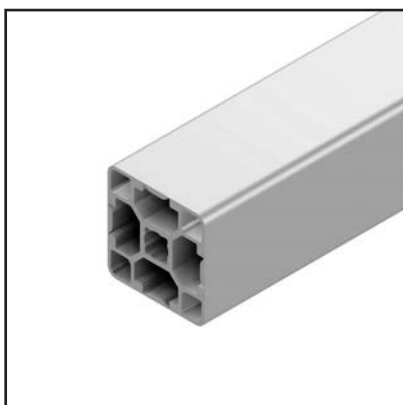
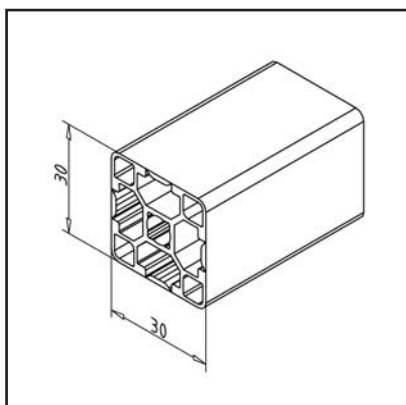
**TECHN. DATA / ITEMS SUPPLIED**

- Aluminium, extruded, anodized E6/EV1
- $I_x = 2.554 \text{ cm}^4$
- $I_y = 2.554 \text{ cm}^4$
- $w_x = 1.702 \text{ cm}^3$
- $w_y = 1.702 \text{ cm}^3$
- Weight = 0.749 kg/m
- Bar length = 6 m
- Packing unit = 54 m

APPLICATIONS

- Light constructions with protective hoods, covers, etc.
- Specifically for high hygiene requirements in the food industry, medical technology, bottling of beverages

ASSEMBLY

- Power-lock fastener 30 / N 30
- Mitre connector 30
- Screw connection 30
- Angle 16 / 30
- Attaching accessories with sliding nut 30 M4 / M5 / M6 / M8

PROFILE 30 X 30 1G

Part no.

20.1139/0

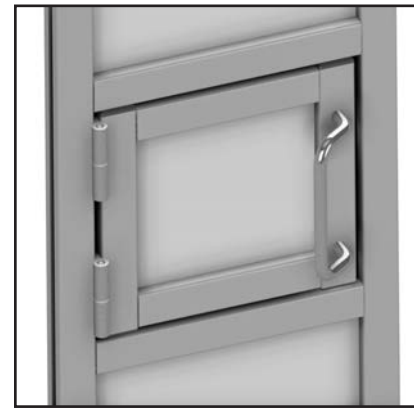
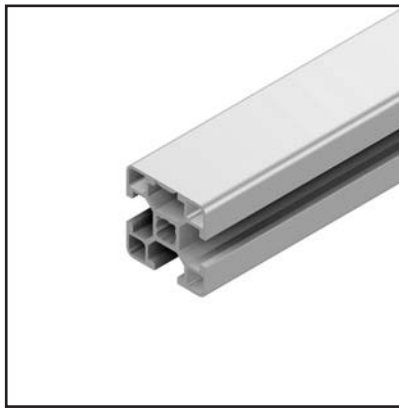
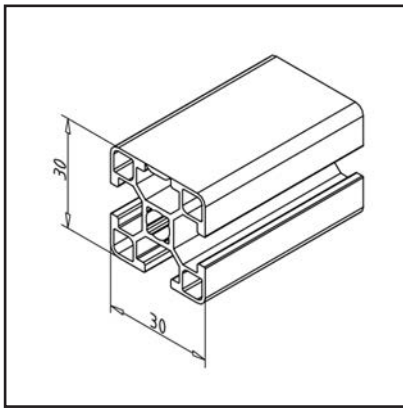

TECHN. DATA / ITEMS SUPPLIED

- Aluminium, extruded, anodized E6/EV1
- $I_x = 2.311 \text{ cm}^4$
- $I_y = 2.112 \text{ cm}^4$
- $w_x = 1.481 \text{ cm}^3$
- $w_y = 1.408 \text{ cm}^3$
- Weight = 0.670 kg/m
- Bar length = 6 m
- Packing unit = 54 m

APPLICATIONS

- Light constructions with protective hoods, covers, etc.
- Specifically for high hygiene requirements in the food industry, medical technology, bottling of beverages

ASSEMBLY

- Power-lock fastener 30 / N 30
- Mitre connector 30
- Screw connection 30
- Angle 16 / 30
- Attaching accessories with sliding nut 30 M4 / M5 / M6 / M8

PROFILE 30 X 30 2G

Part no.

20.1124/0

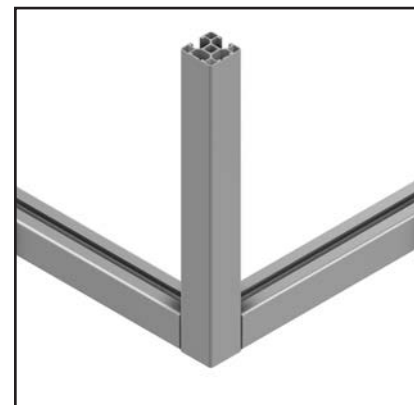
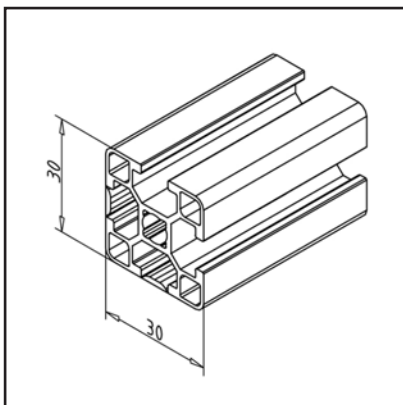

TECHN. DATA / ITEMS SUPPLIED

- Aluminium, extruded, anodized E6/EV1
- $I_x = 2.334 \text{ cm}^4$
- $I_y = 2.334 \text{ cm}^4$
- $w_x = 1.501 \text{ cm}^3$
- $w_y = 1.501 \text{ cm}^3$
- Weight = 0.695 kg/m
- Bar length = 6 m
- Packing unit = 54 m

APPLICATIONS

- Light constructions with protective hoods, covers, etc.
- Specifically for high hygiene requirements in the food industry, medical technology, bottling of beverages

ASSEMBLY

- Power-lock fastener 30 / N 30
- Mitre connector 30
- Screw connection 30
- Angle 16 / 30
- Attaching accessories with sliding nut 30 M4 / M5 / M6 / M8

PROFILE 30 X 30 3G

Part no.

20.1085/0

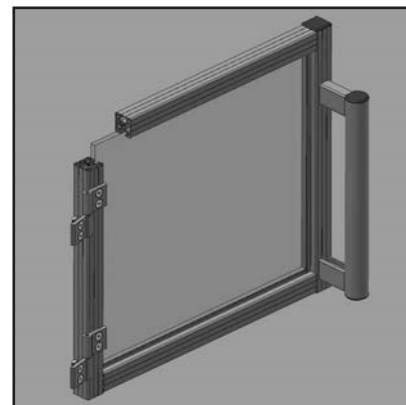
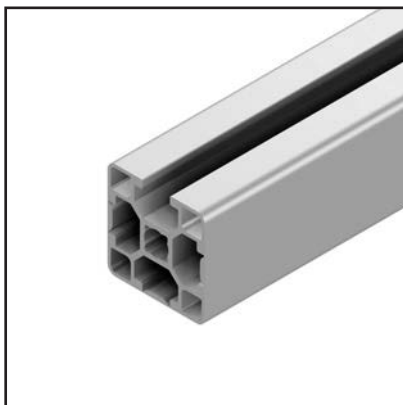
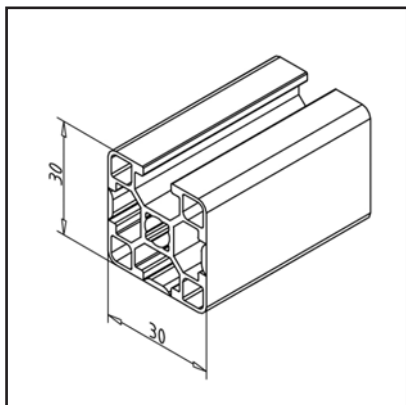
**TECHN. DATA / ITEMS SUPPLIED**

- Aluminium, extruded, anodized E6/EV1
- $I_x = 2.321 \text{ cm}^4$
- $I_y = 2.537 \text{ cm}^4$
- $w_x = 1.493 \text{ cm}^3$
- $w_y = 1.691 \text{ cm}^3$
- Weight = 0.722 kg/m
- Bar length = 6 m
- Packing unit = 54 m

APPLICATIONS

- Light constructions with protective hoods, covers, etc.
- Specifically for high hygiene requirements in the food industry, medical technology, bottling of beverages

ASSEMBLY

- Power-lock fastener 30 / N 30
- Mitre connector 30
- Screw connection 30
- Angle 16 / 30
- Attaching accessories with sliding nut 30 M4 / M5 / M6 / M8

PROFILE 30 X 60

Part no.

20.0994/0

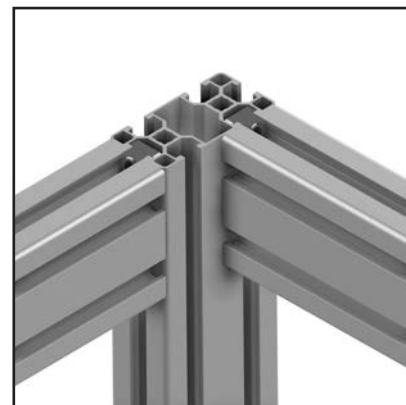
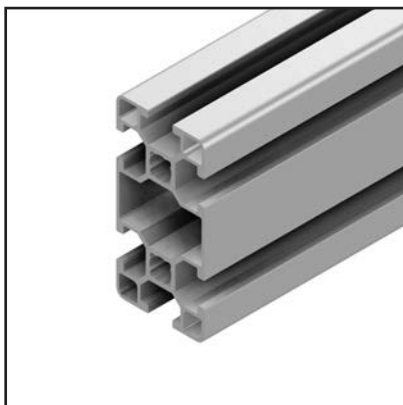
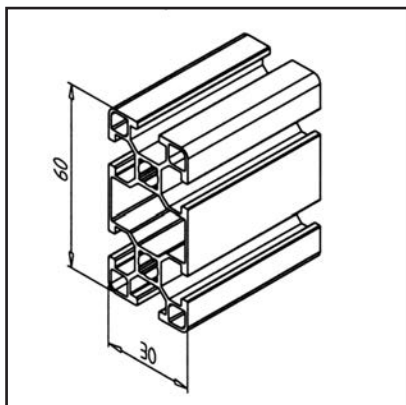
**TECHN. DATA / ITEMS SUPPLIED**

- Aluminium, extruded, anodized E6/EV1
- $I_x = 14.898 \text{ cm}^4$
- $I_y = 3.792 \text{ cm}^4$
- $w_x = 4.966 \text{ cm}^3$
- $w_y = 2.528 \text{ cm}^3$
- Weight = 1.069 kg/m
- Bar length = 6 m
- Packing unit = 54 m

APPLICATIONS

- Light constructions with protective hoods, covers, etc.

ASSEMBLY

- Power-lock fastener 30 / N 30
- Mitre connector 30
- Screw connection 30
- Angle 16 / 30
- Attaching accessories with sliding nut 30 M4 / M5 / M6 / M8

PROFILE 60 X 60 X 30

Part no.

20.0982/0

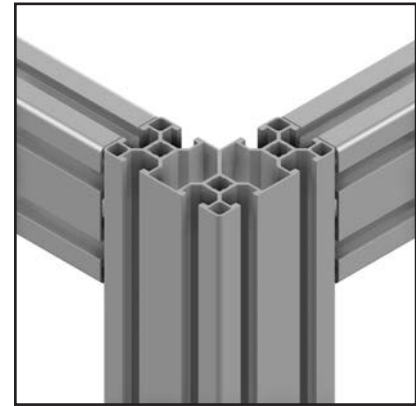
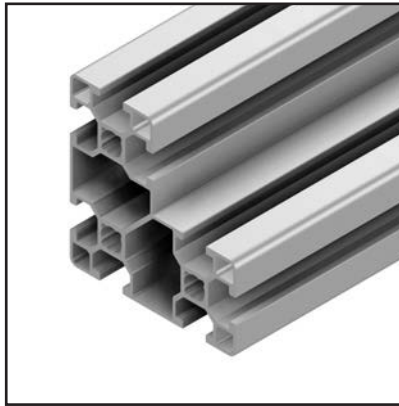
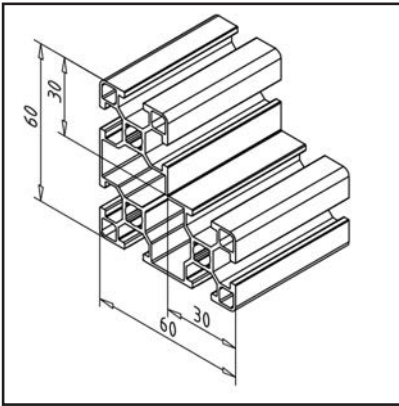

TECHN. DATA / ITEMS SUPPLIED

- Aluminium, extruded, anodized E6/EV1
- $I_x = 19.107 \text{ cm}^4$
- $I_y = 19.107 \text{ cm}^4$
- $w_x = 5.572 \text{ cm}^3$
- $w_y = 5.572 \text{ cm}^3$
- Weight = 1.534 kg/m
- Bar length = 6 m
- Packing unit = 36 m

APPLICATIONS

- Weight optimized constructions
- Tables
- Framework constructions
- display windows, showcases

ASSEMBLY

- Power-lock fastener 30 / N 30
- Screw connection 30
- Angle 16 / 30
- Attaching accessories with sliding nut 30 M4 / M5 / M6 / M8
- Base and transport plate 60x60x30 **part no. 21.0038/0**

PROFILE 30 R 30°

Part no.

20.1134/0

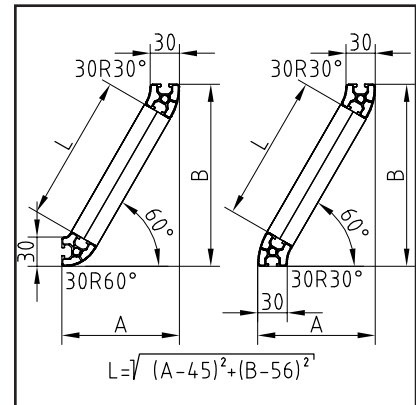
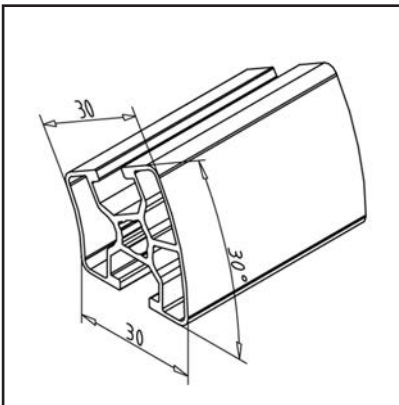

TECHN. DATA / ITEMS SUPPLIED

- Aluminium, extruded, anodized E6/EV1
- $I_x = 1.939 \text{ cm}^4$
- $I_y = 1.909 \text{ cm}^4$
- $w_x = 0.982 \text{ cm}^3$
- $w_y = 1.006 \text{ cm}^3$
- Weight = 0.601 kg/m
- Bar length = 6 m
- Packing unit = 72 m

APPLICATIONS

- Weight optimized constructions
- Tables
- Framework constructions
- display windows, showcases
- As cross beam:
Calculate dimension L of the intermediate support according to calculating formula

ASSEMBLY

- Power-lock fastener 30 / N 30
- Mitre connector 30
- Screw connection 30
- Angle 16 / 30
- Attaching accessories with sliding nut 30 M4 / M5 / M6 / M8

PROFILE 30 R 45°

Part no.

20.1135/0

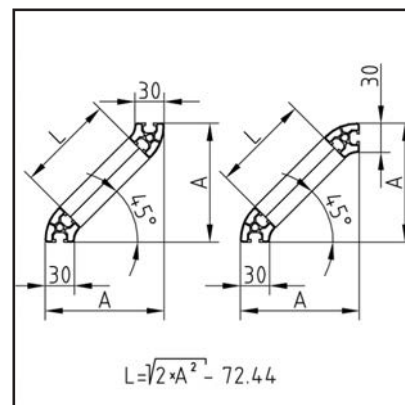
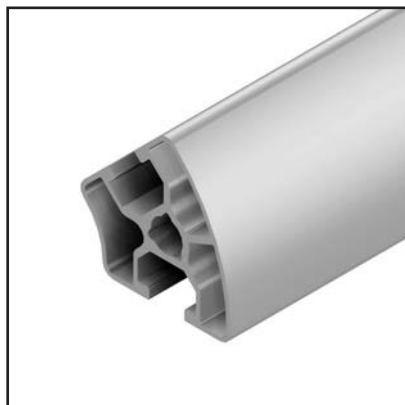
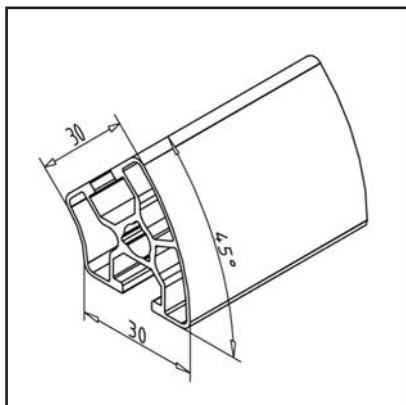
**TECHN. DATA / ITEMS SUPPLIED**

- Aluminium, extruded, anodized E6/EV1
- $I_x = 1.909 \text{ cm}^4$
- $I_y = 1.812 \text{ cm}^4$
- $w_x = 0.924 \text{ cm}^3$
- $w_y = 0.951 \text{ cm}^3$
- Weight = 0.601 kg/m
- Bar length = 6 m
- Packing unit = 72 m

APPLICATIONS

- Weight optimized constructions
- Tables
- Framework constructions
- As cross beam:
Calculate dimension L of the intermediate support according to calculating formula
- display windows, showcases

ASSEMBLY

- Power-lock fastener 30 / N 30
- Mitre connector 30
- Screw connection 30
- Angle 16 / 30
- Attaching accessories with sliding nut 30 M4 / M5 / M6 / M8

PROFILE 30 R 60°

Part no.

20.1136/0

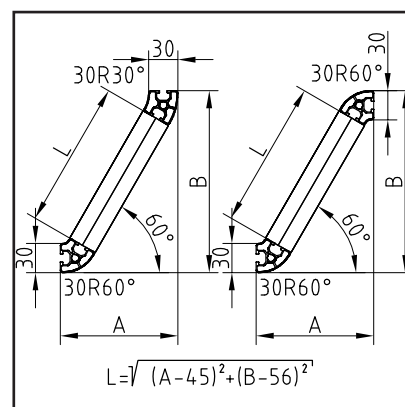
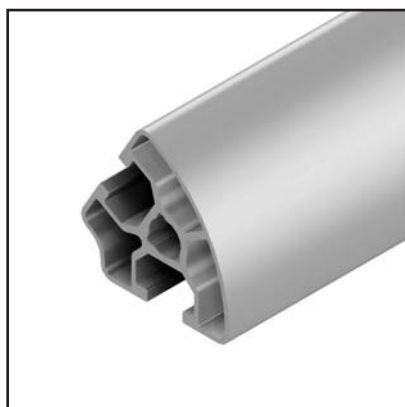
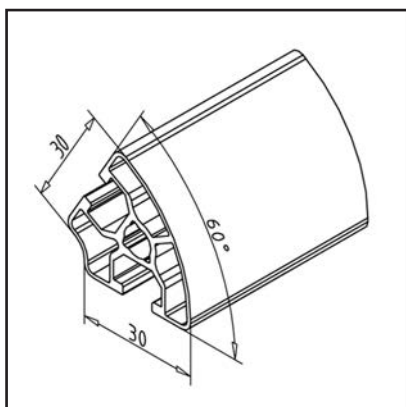
**TECHN. DATA / ITEMS SUPPLIED**

- Aluminium, extruded, anodized E6/EV1
- $I_x = 1.847 \text{ cm}^4$
- $I_y = 1.721 \text{ cm}^4$
- $w_x = 0.904 \text{ cm}^3$
- $w_y = 0.951 \text{ cm}^3$
- Weight = 0.590 kg/m
- Bar length = 6 m
- Packing unit = 72 m

APPLICATIONS

- Weight optimized constructions
- Tables
- Framework constructions
- display windows, showcases
- As cross beam:
Calculate dimension L of the intermediate support according to calculating formula

ASSEMBLY

- Power-lock fastener 30 / N 30
- Mitre connector 30
- Screw connection 30
- Angle 16 / 30
- Attaching accessories with sliding nut 30 M4 / M5 / M6 / M8

PROFILE 30 R 90°

Part no.

20.1125/0

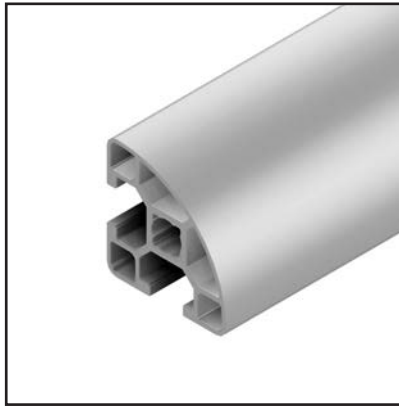
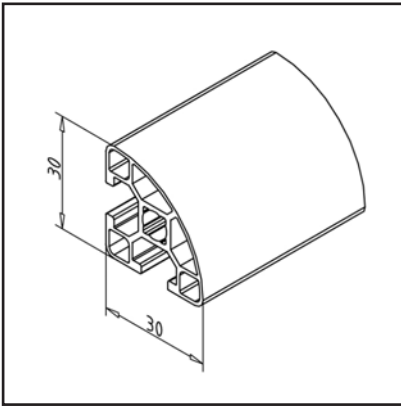

TECHN. DATA / ITEMS SUPPLIED

- Aluminium, extruded, anodized E6/EV1
- $I_x = 1.847 \text{ cm}^4$
- $I_y = 1.721 \text{ cm}^4$
- $w_x = 0.904 \text{ cm}^3$
- $w_y = 0.951 \text{ cm}^3$
- Weight = 0.580 kg/m
- Bar length = 6 m
- Packing unit = 54 m

APPLICATIONS

- Weight optimized constructions
- Tables
- Framework constructions
- display windows, showcases

ASSEMBLY

- Power-lock fastener 30 / N 30
- Mitre connector 30
- Screw connection 30
- Angle 16 / 30 / 30 R 90°
- Attaching accessories with sliding nut 30 M4 / M5 / M6 / M8

PROFILE 19 X 32

Part no.

20.1000/0

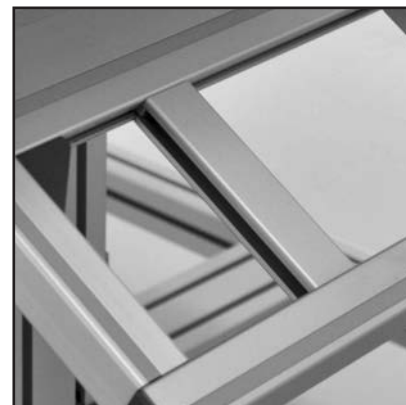
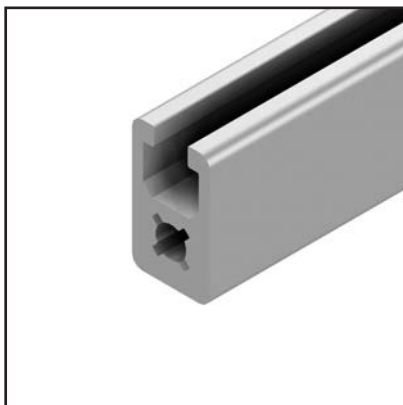
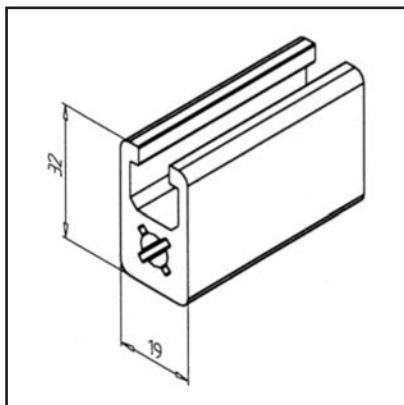
**TECHN. DATA / ITEMS SUPPLIED**

- Aluminium, extruded, anodized E6/EV1
- $I_x = 3.102 \text{ cm}^4$
- $I_y = 1.526 \text{ cm}^4$
- $w_x = 1.651 \text{ cm}^3$
- $w_y = 1.606 \text{ cm}^3$
- Weight = 0.987 kg/m
- Bar length = 6 m
- Packing unit = 60 m

APPLICATIONS

- Light constructions
- Handle bars
- Carrier for initiators, switches
- Frames

ASSEMBLY

- MiniTec power-lock fastener
- Angle 19 GD-Z, **part no. 21.2078/0**
- Bolt connector
- Screw connection

PROFILE 19 X 45

Part no.

20.1001/0

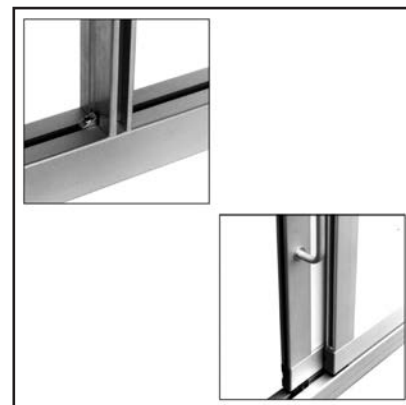
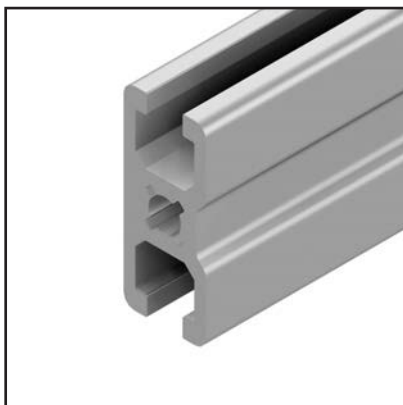
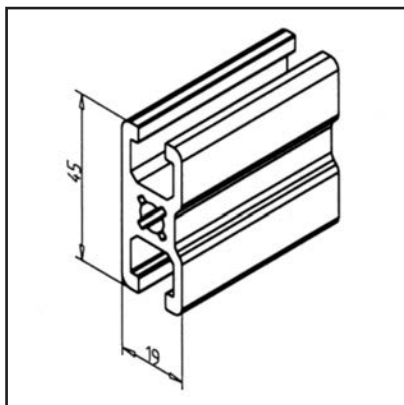
**TECHN. DATA / ITEMS SUPPLIED**

- Aluminium, extruded, anodized E6/EV1
- $I_x = 6.173 \text{ cm}^4$
- $I_y = 1.843 \text{ cm}^4$
- $w_x = 2.743 \text{ cm}^3$
- $w_y = 1.836 \text{ cm}^3$
- Weight = 1.101 kg/m
- Bar length = 6 m
- Packing unit = 60 m

APPLICATIONS

- Bracing, doors
- Guard units
- Weight optimized constructions
- Frames

ASSEMBLY

- MiniTec power-lock fastener
- Angle 19 GD-Z, **part no. 21.2078/0**
- Bolt connector
- Screw connection

PROFILE 45 X 19

Part no.

20.0993/0

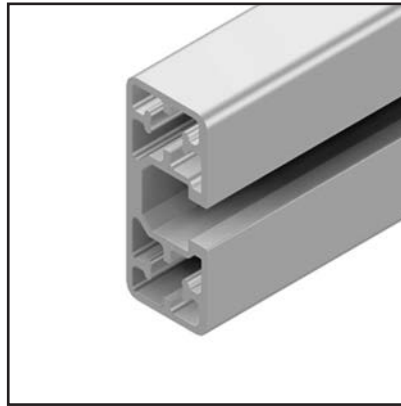
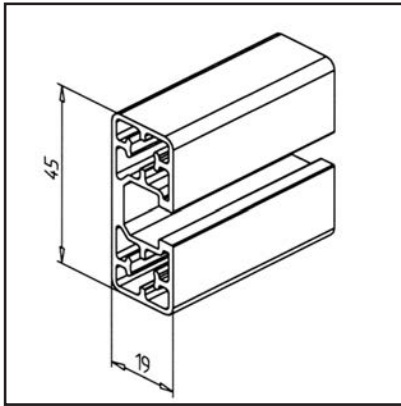

TECHN. DATA / ITEMS SUPPLIED

- Aluminium, extruded, anodized E6/EV1
- $I_x = 6.106 \text{ cm}^4$
- $I_y = 1.384 \text{ cm}^4$
- $w_x = 2.71 \text{ cm}^3$
- $w_y = 1.45 \text{ cm}^3$
- Weight = 0.814 kg/m
- Bar length = 6 m
- Packing unit = 72 m

APPLICATIONS

- Weight-optimized constructions
- Light constructions
- Light sliding windows
- Support plates
- Base plates

ASSEMBLY

- side 19 with MiniTec power lock fastener, **part no. 21.0818/0**
- 45th page with angle mounting bracket, profile connector N or connector

PROFILE 32 X 32 UL

Part no.

20.1064/0

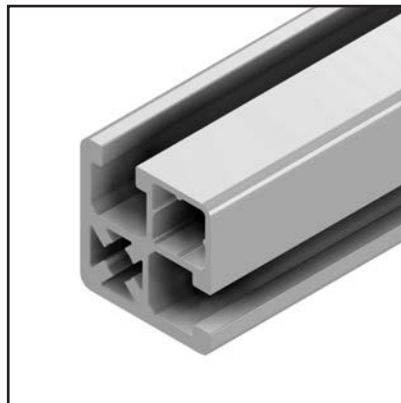
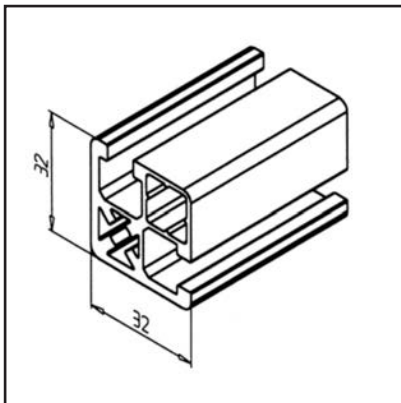

TECHN. DATA / ITEMS SUPPLIED

- Aluminium, extruded, anodized E6/EV1
- $I_x = 4.1 \text{ cm}^4$
- $I_y = 4.1 \text{ cm}^4$
- $w_x = 2.267 \text{ cm}^3$
- $w_y = 2.267 \text{ cm}^3$
- Weight = 1.052 kg/m
- Bar length = 6 m
- Packing unit = 48 m

APPLICATIONS

- Weight-optimized constructions
- End table
- Swivel, lifting and sliding doors
- Bracings

ASSEMBLY

- MiniTec power-lock fastener
- Angle 19 GD-Z, **part no. 21.2078/0**
- Bolt connector
- Screw connection

PROFILE 32 X 32 F

Part no.

20.1054/0

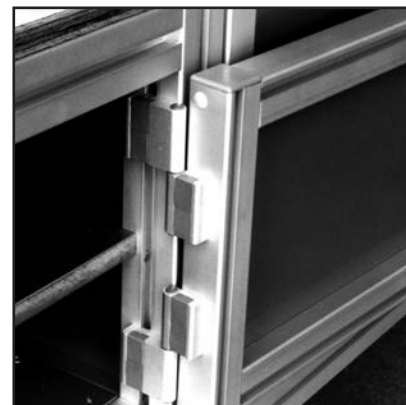
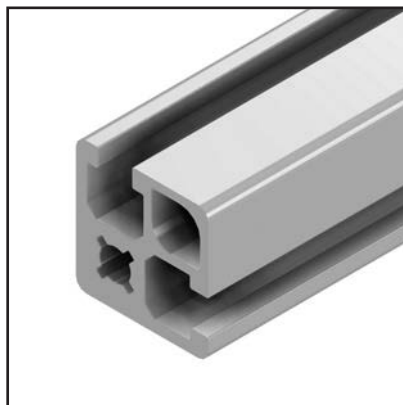
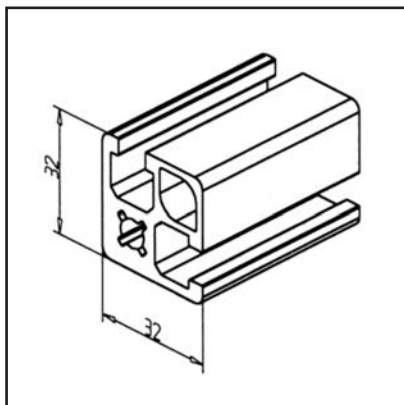

TECHN. DATA / ITEMS SUPPLIED

- Aluminium, extruded, anodized E6/EV1
- $I_x = 4.825 \text{ cm}^4$
- $I_y = 4.825 \text{ cm}^4$
- $w_x = 2.703 \text{ cm}^3$
- $w_y = 2.703 \text{ cm}^3$
- Weight = 1.288 kg/m
- Bar length = 6 m
- Packing unit = 48 m

APPLICATIONS

- Weight optimized constructions
- End table
- Swivel, lifting and sliding doors
- Bracings

ASSEMBLY

- MiniTec power-lock fastener
- Angle 19 GD-Z, **part no. 21.2078/0**
- Bolt connector
- Screw connection

CLAMPING PROFILE 32 X 32

Part no.

20.1070/0

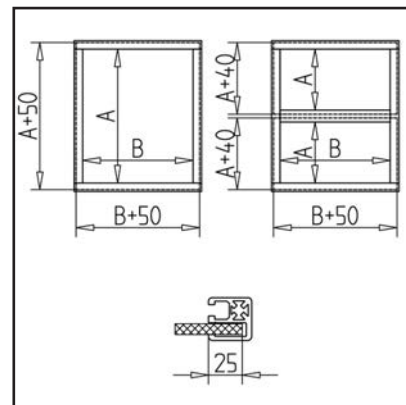
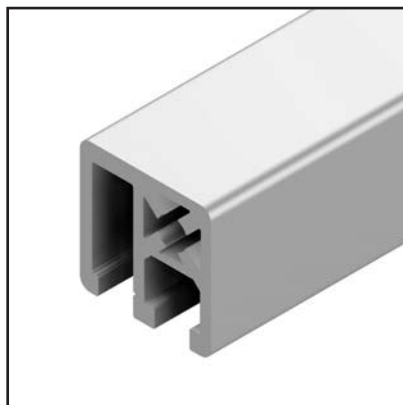
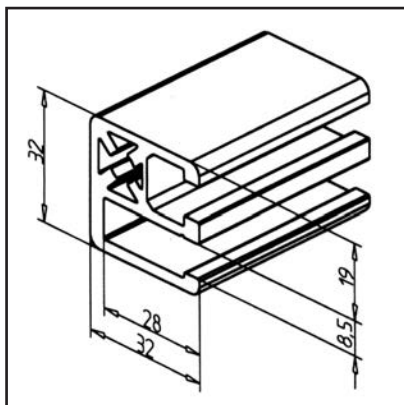

TECHN. DATA / ITEMS SUPPLIED

- Aluminium, extruded, anodized E6/EV1
- $I_x = 5.024 \text{ cm}^4$
- $I_y = 4.418 \text{ cm}^4$
- $w_x = 3.041 \text{ cm}^3$
- $w_y = 2.398 \text{ cm}^3$
- Weight = 1.211 kg/m
- Bar length = 6 m
- Packing unit = 48 m

APPLICATIONS

- All types of safety equipment
- For clamping of surface elements, such as woven mesh, panels, plates with a maximum strength of 8 mm
- In the case of larger protective fields, intermediate struts made of clamping profile 45 x 32 must be used in order to ensure adequate safety against pushing out of the surface elements; To do this, remove cover strips on clamping profile 45 x 32 mm
- Cut size of surface elements:
Dimension A/B - 40/50 mm depending on application

ASSEMBLY

- MiniTec power-lock fastener; no bores required
- No release of panel element corners required
- Pre-assemble tripartite frame
- Insert panel element and install last profile brace
- Press in the distance profile **part no. 22.1039/0** on the inside or drive in with a flat tool
- For panel elements < Mount 6 mm with matching plug-in seal or < Mount 4 mm with spacer profile and additionally suitable plug-in seal on the opposite side

PROFILE 45 X 32 UL

Part no.

20.1065/0

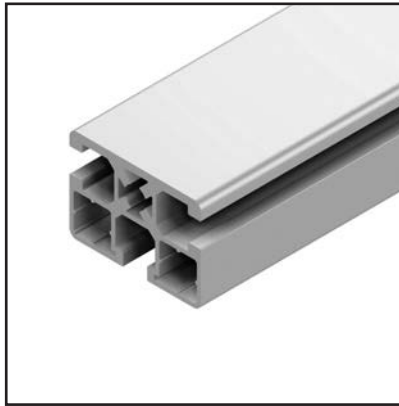
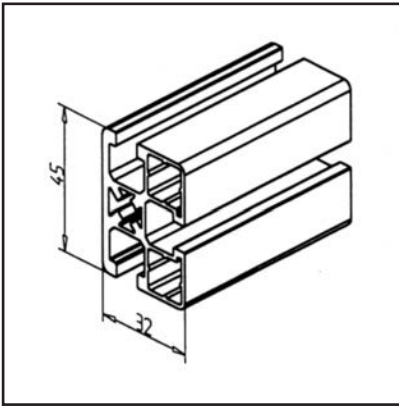

TECHN. DATA / ITEMS SUPPLIED

- Aluminium, extruded, anodized E6/EV1
- $I_x = 8.292 \text{ cm}^4$
- $I_y = 5.178 \text{ cm}^4$
- $w_x = 3.685 \text{ cm}^3$
- $w_y = 2.815 \text{ cm}^3$
- Weight = 1.257 kg/m
- Bar length = 6 m
- Packing unit = 48 m

APPLICATIONS

- All types of constructions, with a closed profile side
- Weight-optimized constructions
- Tables
- Frames
- Sliding doors

ASSEMBLY

- MiniTec power-lock fastener
- Angle 19 / 25 / 45 / 45 x 90 GD-Z
- Bolt connector
- Screw connection

PROFILE 45 X 32 F

Part no.

20.1055/0

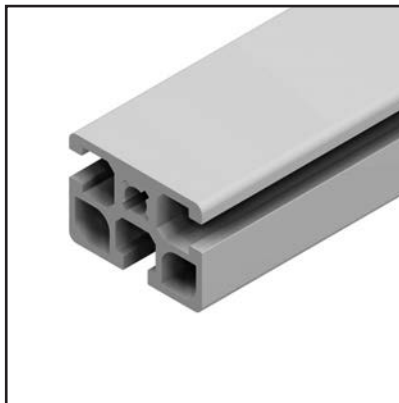
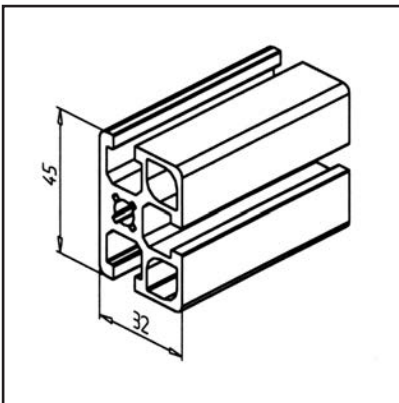

TECHN. DATA / ITEMS SUPPLIED

- Aluminium, extruded, anodized E6/EV1
- $I_x = 10.189 \text{ cm}^4$
- $I_y = 6.499 \text{ cm}^4$
- $w_x = 4.528 \text{ cm}^3$
- $w_y = 3.762 \text{ cm}^3$
- Weight = 1.588 kg/m
- Bar length = 6 m
- Packing unit = 48 m

APPLICATIONS

- All types of constructions, with a closed profile side
- Tables
- Frames
- Sliding doors
- Rails

ASSEMBLY

- MiniTec power-lock fastener
- Angle 19 / 25 / 45 / 45 x 90 GD-Z
- Bolt connector
- Screw connection

CLAMPING PROFILE 45 X 32

Part no.

20.1053/0

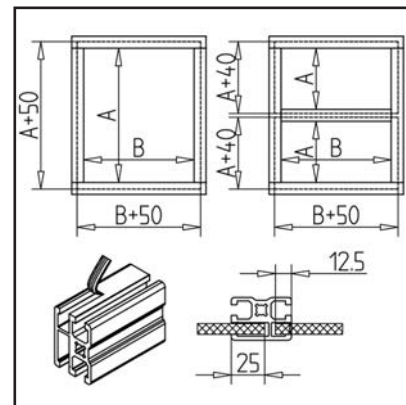
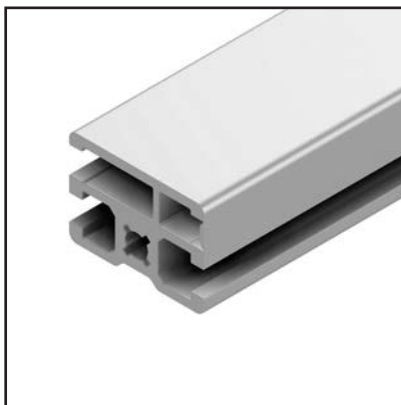
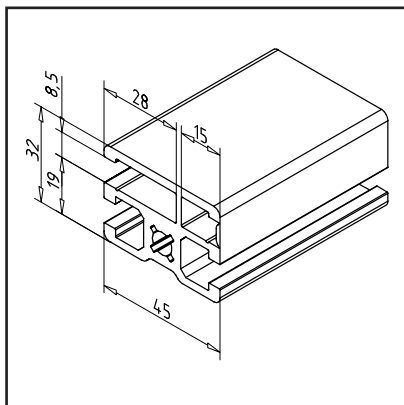

TECHN. DATA / ITEMS SUPPLIED

- Aluminium, extruded, anodized E6/EV1
- $I_x = 6.465 \text{ cm}^4$
- $I_y = 9.521 \text{ cm}^4$
- $w_x = 3.999 \text{ cm}^3$
- $w_y = 4.119 \text{ cm}^3$
- Weight = 1.615 kg/m
- Bar length = 6 m
- Packing unit = 48 m

APPLICATIONS

- In the case of larger protective fields, intermediate struts made of clamping profile 45 x 32 must be used in order to ensure adequate safety against pushing out of the surface elements; To do this, remove cover strips on clamping profile 45 x 32 mm
- All types of safety equipment
- For clamping of surface elements, such as woven mesh, panels, plates with a maximum strength of 8 mm
- Cut size of surface elements: Dimension A/B - 40/50 mm depending on application

ASSEMBLY

- MiniTec power-lock fastener; no bores required
- No release of panel element corners required
- Pre-assemble tripartite frame
- Insert panel element and install last profile brace
- Press in the distance profile **part no. 22.1039/0** on the inside or drive in with a flat tool
- For panel elements < Mount 6 mm with matching plug-in seal or < Mount 4 mm with spacer profile and additionally suitable plug-in seal on the opposite side

PROFILE 45 X 45 UL

Part no.

20.1063/0

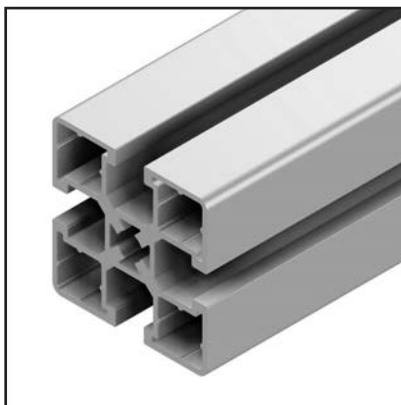
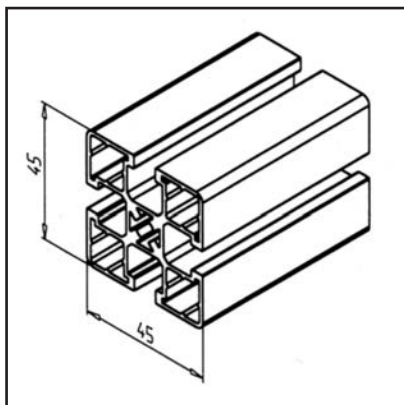

TECHN. DATA / ITEMS SUPPLIED

- Aluminium, extruded, anodized E6/EV1
- $I_x = 9.953 \text{ cm}^4$
- $I_y = 9.953 \text{ cm}^4$
- $w_x = 4.423 \text{ cm}^3$
- $w_y = 4.423 \text{ cm}^3$
- Weight = 1.445 kg/m
- Bar length = 6 m
- Packing unit = 54 m

APPLICATIONS

- Weight-optimized constructions
- All kinds of constructions

ASSEMBLY

- MiniTec power-lock fastener
- Angle 19 / 25 / 45 / 45 x 90 GD-Z
- Bolt connector
- Screw connection

PROFILE 45 X 45 F

Part no.

20.1033/0

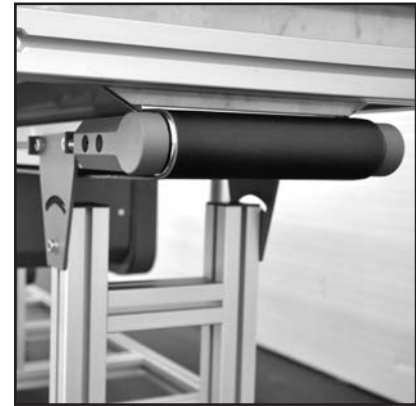
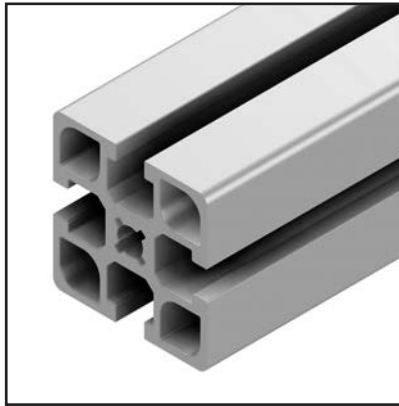
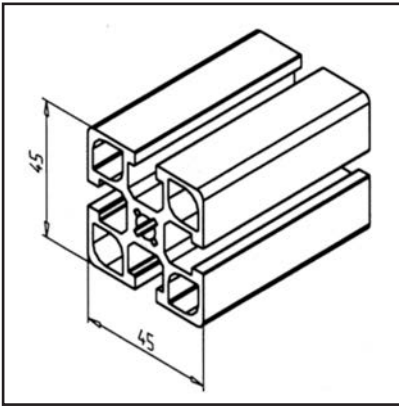

TECHN. DATA / ITEMS SUPPLIED

- Aluminium, extruded, anodized E6/EV1
- $I_x = 14.172 \text{ cm}^4$
- $I_y = 14.172 \text{ cm}^4$
- $w_x = 6.298 \text{ cm}^3$
- $w_y = 6.298 \text{ cm}^3$
- Weight = 2.005 kg/m
- Bar length = 6 m
- Packing unit = 36 m

APPLICATIONS

- All kinds of constructions

ASSEMBLY

- MiniTec power-lock fastener
- Angle 19 / 25 / 45 / 45 x 90 GD-Z
- Bolt connector
- Screw connection

PROFILE 45 X 45

Part no.

20.1006/0

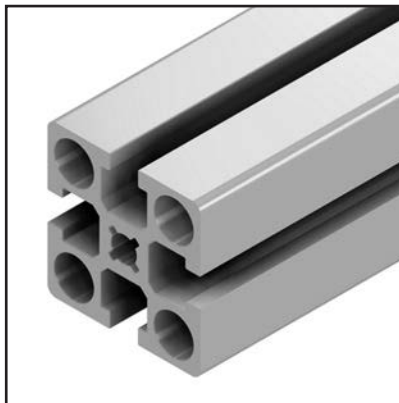
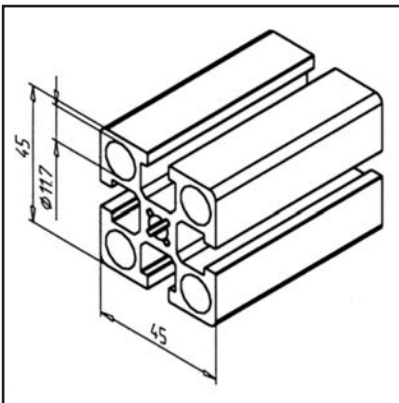

TECHN. DATA / ITEMS SUPPLIED

- Aluminium, extruded, anodized E6/EV1
- $I_x = 15.934 \text{ cm}^4$
- $I_y = 15.934 \text{ cm}^4$
- $w_x = 7.081 \text{ cm}^3$
- $w_y = 7.081 \text{ cm}^3$
- Weight = 2.205 kg/m
- Bar length = 6 m
- Packing unit = 36 m

APPLICATIONS

- General constructions
- Compressed air piping
- Linear guides

ASSEMBLY

- MiniTec power-lock fastener
- Angle 25 / 45, bolt-fastener, screw connection
- The $\text{Ø } 11.7 \text{ mm}$ holes can be bored with G 1/4 for holding screw plugs or pneumatic connections
- Lateral connections G 1/8" direct into the profile

CLAMPING PROFILE 45 X 45 F

Part no.

20.1147/0

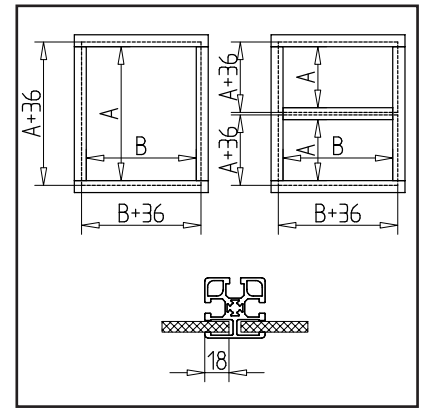
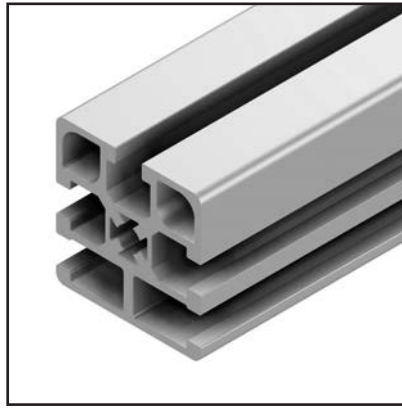
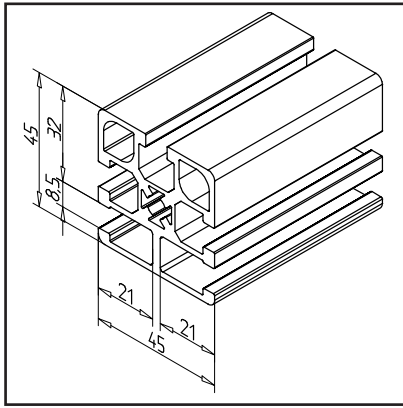

TECHN. DATA / ITEMS SUPPLIED

- Aluminium, extruded, anodized E6/EV1
- $I_x = 13.521 \text{ cm}^4$
- $I_y = 12.308 \text{ cm}^4$
- $w_x = 5.836 \text{ cm}^3$
- $w_y = 5.470 \text{ cm}^3$
- Weight = 1.850 kg/m
- Bar length = 6 m
- Packing unit = 36 m

APPLICATIONS

- For clamping of surface elements, such as woven mesh, panels, plates with a maximum strength of 8 mm
- All types of safety equipment
- Cut size of surface elements: Dimension A/B - 36 mm

ASSEMBLY

- MiniTec power-lock fastener; no bores required
- No release of panel element corners required
- Pre-assemble tripartite frame
- Insert panel element and install last profile brace
- Press in the distance profile **part no. 22.1039/0** on the inside or drive in with a flat tool
- For panel elements < Mount 6 mm with matching plug-in seal or < Mount 4 mm with spacer profile and additionally suitable plug-in seal on the opposite side

PROFILE 45 X 45 G

Part no.

20.1028/0

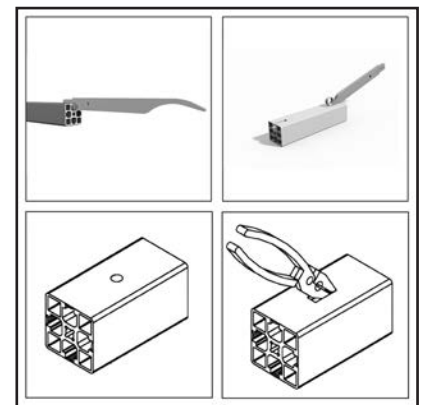
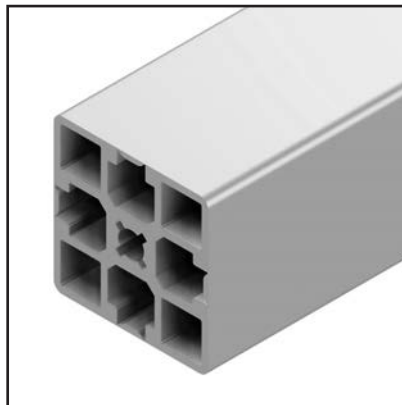
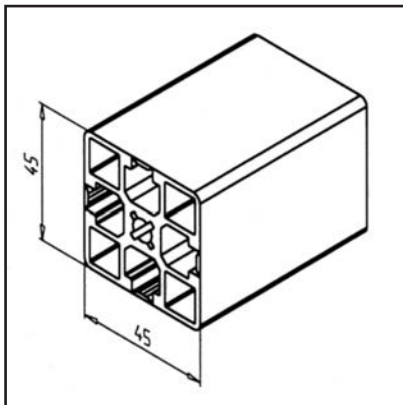

TECHN. DATA / ITEMS SUPPLIED

- Aluminium, extruded, anodized E6/EV1
- $I_x = 14.087 \text{ cm}^4$
- $I_y = 14.087 \text{ cm}^4$
- $w_x = 6.261 \text{ cm}^3$
- $w_y = 6.261 \text{ cm}^3$
- Weight = 1.997 kg/m
- Bar length = 6 m
- Packing unit = 36 m

APPLICATIONS

- All types of constructions, specifically for high hygiene requirements in the food industry, medical technology, bottling of beverages
- To close open grooves with the cover profile L **part no. 20.1021/0**
- Silicon sealings for profile connections on request

ASSEMBLY

- For tightening the MiniTec power-lock fastener, the groove cover must be opened by tear-off lever **part no. 26.0815/0** at the profile end. Opening can be covered with end cap profile G **part no. 22.1056/1**
- Angle 25 / 45
- closed grooves can be opened with the groove opener **part no. 26.0815/0** to the desired length

PROFILE 45 X 45 1G

Part no. 20.1126/0

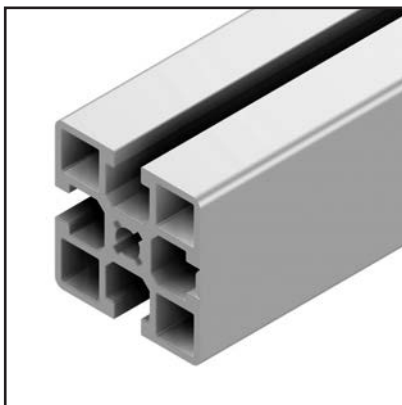
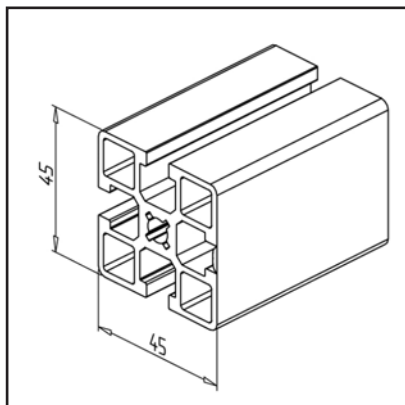

TECHN. DATA / ITEMS SUPPLIED

APPLICATIONS

ASSEMBLY

- Aluminium, extruded, anodized E6/EV1
- $I_x = 13.617 \text{ cm}^4$
- $I_y = 14.091 \text{ cm}^4$
- $w_x = 6.052 \text{ cm}^3$
- $w_y = 6.262 \text{ cm}^3$
- Weight = 1.897 kg/m
- Bar length = 6 m
- Packing unit = 36 m

- Grooves expandable
- All types of constructions, specifically for high hygiene requirements in the food industry, medical technology, bottling of beverages
- To close open grooves with the cover profile L **part no. 20.1021/0**
- Silicon sealings for profile connections on request

- For tightening the MiniTec power-lock fastener, the groove cover must be opened by tear-off lever **part no. 26.0815/0** at the profile end. Opening can be covered with end cap profile G **part no. 22.1056/1**
- Angle 25 / 45
- closed grooves can be opened with the groove opener **part no. 26.0815/0** to the desired length

PROFILE 45 X 45 2G

Part no. 20.1072/0

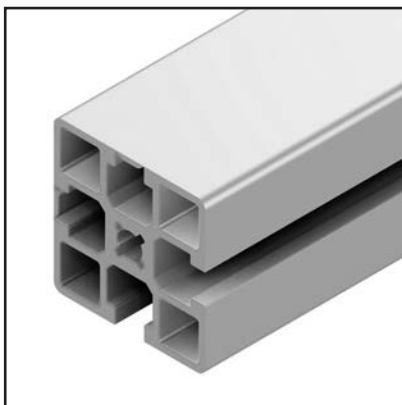
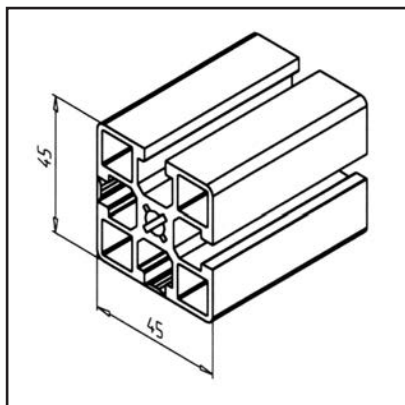

TECHN. DATA / ITEMS SUPPLIED

APPLICATIONS

ASSEMBLY

- Aluminium, extruded, anodized E6/EV1
- $I_x = 13.549 \text{ cm}^4$
- $I_y = 13.549 \text{ cm}^4$
- $w_x = 5.938 \text{ cm}^3$
- $w_y = 5.938 \text{ cm}^3$
- Weight = 1.925 kg/m
- Bar length = 6 m
- Packing unit = 36 m

- All types of constructions, specifically for high hygiene requirements in the food industry, medical technology, bottling of beverages
- To close open grooves with the cover profile L **part no. 20.1021/0**
- Silicon sealings for profile connections on request

- For tightening the MiniTec power-lock fastener, the groove cover must be opened by tear-off lever **part no. 26.0815/0** at the profile end. Opening can be covered with end cap profile G **part no. 22.1056/1**
- Angle 25 / 45
- closed grooves can be opened with the groove opener **part no. 26.0815/0** to the desired length

PROFILE 45 X 45 UL 2GG

Part no.

20.1122/0

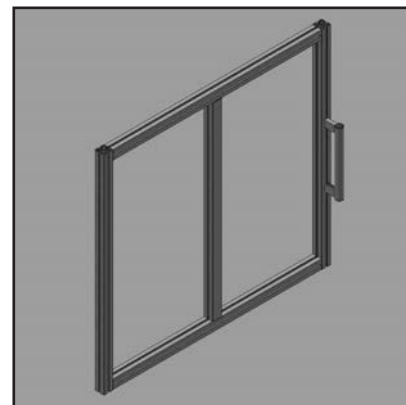
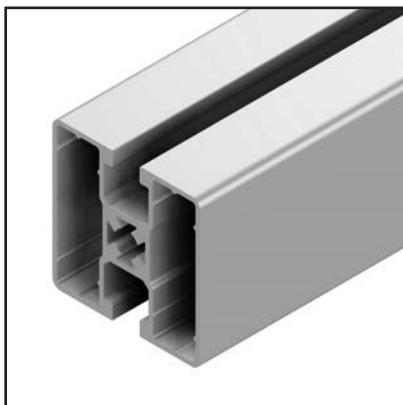
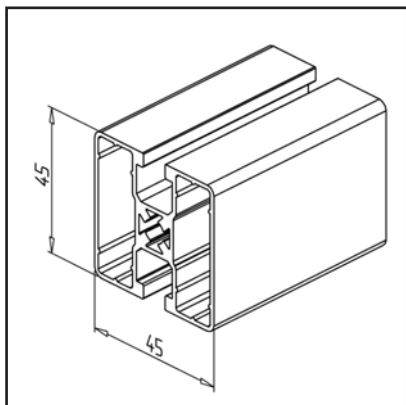

TECHN. DATA / ITEMS SUPPLIED

- Aluminium, extruded, anodized E6/EV1
- $I_x = 9.974 \text{ cm}^4$
- $I_y = 8.553 \text{ cm}^4$
- $w_x = 4.432 \text{ cm}^3$
- $w_y = 3.801 \text{ cm}^3$
- Weight = 1.254 kg/m
- Bar length = 6 m
- Packing unit = 54 m

APPLICATIONS

- Weight-optimized constructions
- All types of constructions, specifically for high hygiene requirements in the food industry, medical technology, bottling of beverages
- Silicon sealings for profile connections on request

ASSEMBLY

- MiniTec power-lock fastener
- Angle 19 / 25 / 45 / 45 x 90 GD-Z
- Bolt connector
- Screw connection

PROFILE 45 X 45 2GG

Part no.

20.1099/0

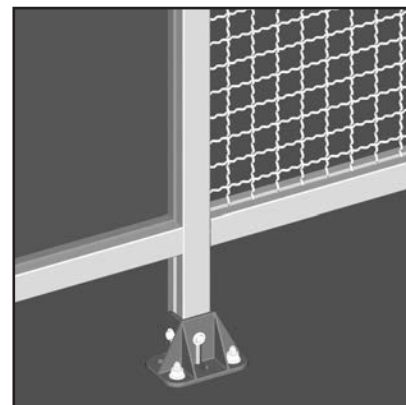
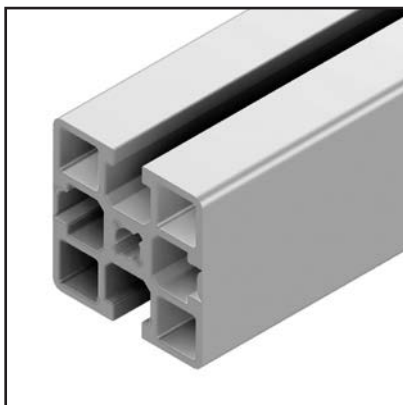
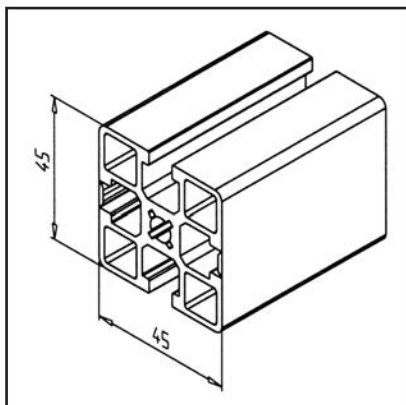

TECHN. DATA / ITEMS SUPPLIED

- Aluminium, extruded, anodized E6/EV1
- $I_x = 13.069 \text{ cm}^4$
- $I_y = 14.045 \text{ cm}^4$
- $w_x = 5.808 \text{ cm}^3$
- $w_y = 6.242 \text{ cm}^3$
- Weight = 1.925 kg/m
- Bar length = 6 m
- Packing unit = 36 m

APPLICATIONS

- All types of constructions, specifically for high hygiene requirements in the food industry, medical technology, bottling of beverages
- To close open grooves with the cover profile L **part no. 20.1021/0**
- Silicon sealings for profile connections on request

ASSEMBLY

- For tightening the MiniTec power-lock fastener, the groove cover must be opened by tear-off lever **part no. 26.0815/0** at the profile end. Opening can be covered with end cap profile G **part no. 22.1056/1**
- Angle 25 / 45
- closed grooves can be opened with the groove opener **part no. 26.0815/0** to the desired length

PROFILE 45 X 45 UL 3G

Part no.

20.1123/0

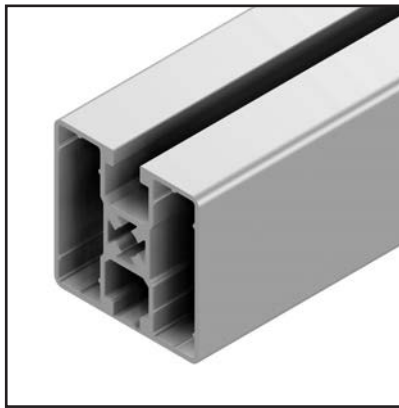
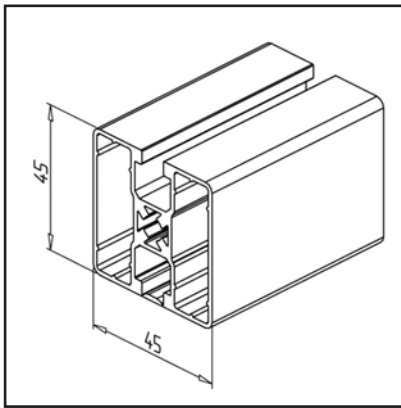

TECHN. DATA / ITEMS SUPPLIED

- Aluminium, extruded, anodized E6/EV1
- $I_x = 10.44 \text{ cm}^4$
- $I_y = 8.557 \text{ cm}^4$
- $w_x = 4.64 \text{ cm}^3$
- $w_y = 3.803 \text{ cm}^3$
- Weight = 1.281 kg/m
- Bar length = 6 m
- Packing unit = 54 m

APPLICATIONS

- Grooves expandable
- Weight-optimized constructions
- All types of constructions, specifically for high hygiene requirements in the food industry, medical technology, bottling of beverages
- Silicon sealings for profile connections on request

ASSEMBLY

- MiniTec power-lock fastener
- Angle 19 / 25 / 45 / 45 x 90 GD-Z
- Screw connection

PROFILE 45 X 45 3G

Part no.

20.1048/0

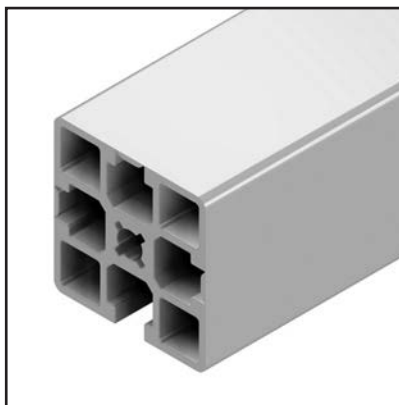
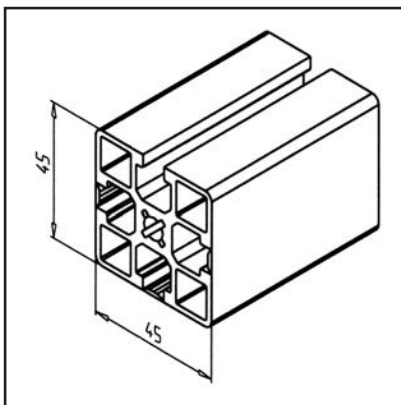

TECHN. DATA / ITEMS SUPPLIED

- Aluminium, extruded, anodized E6/EV1
- $I_x = 13.554 \text{ cm}^4$
- $I_y = 14.049 \text{ cm}^4$
- $w_x = 5.941 \text{ cm}^3$
- $w_y = 6.244 \text{ cm}^3$
- Weight = 1.953 kg/m
- Bar length = 6 m
- Packing unit = 36 m

APPLICATIONS

- All types of constructions, specifically for high hygiene requirements in the food industry, medical technology, bottling of beverages
- To close open grooves with the cover profile L **part no. 20.1021/0**
- Silicon sealings for profile connections on request

ASSEMBLY

- For tightening the MiniTec power-lock fastener, the groove cover must be opened by tear-off lever **part no. 26.0815/0** at the profile end. Opening can be covered with end cap profile G **part no. 22.1056/1**
- Angle 25 / 45
- closed grooves can be opened with the groove opener **part no. 26.0815/0** to the desired length

PROFILE 45 X 45 SST

Part no.

20.2000/0

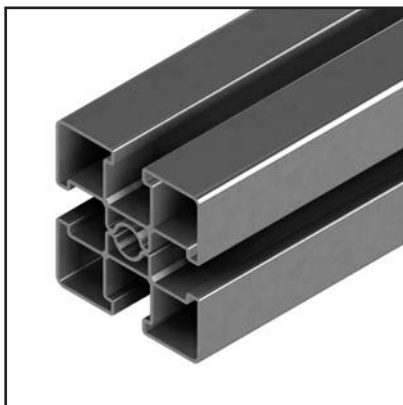
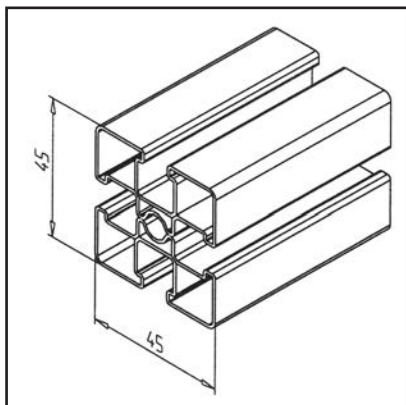
**TECHN. DATA / ITEMS SUPPLIED**

- Stainless steel, Rolled, bright
- $I_x = 6.47 \text{ cm}^4$
- $I_y = 6.47 \text{ cm}^4$
- $w_x = 2.88 \text{ cm}^3$
- $w_y = 2.88 \text{ cm}^3$
- Material: WN DIN 1.4301 (X5 Cr Ni 18-10, SUS 304)
- Weight = 2.712 kg/m
- Bar length = 6 m
- Packing unit = 24 m

APPLICATIONS

- Food and beverage industry
- Outdoor constructions
- Chemical industry
- Pharmaceutical industry
- High temperatures

ASSEMBLY

- Power-lock fastener H, **part no. 21.1018/1**
- Angles
- Screws M8, stainless

PROFILE 45 X 45 R

Part no.

20.1046/0

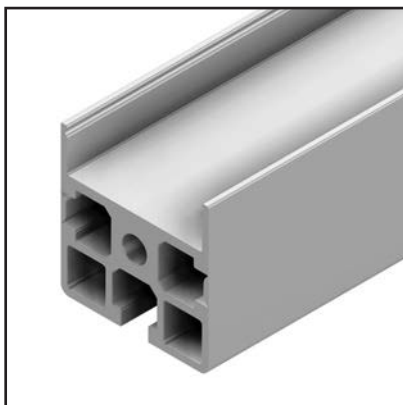
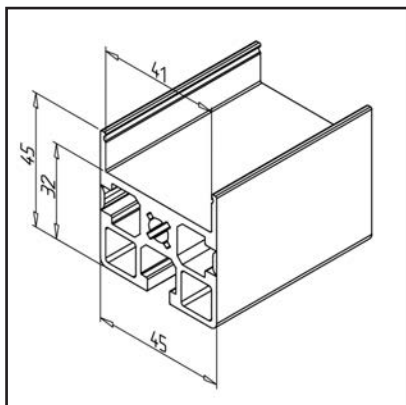
**TECHN. DATA / ITEMS SUPPLIED**

- Aluminium, extruded, anodized E6/EV1
- $I_x = 8.296 \text{ cm}^4$
- $I_y = 12.997 \text{ cm}^4$
- $w_x = 3.247 \text{ cm}^3$
- $w_y = 5.776 \text{ cm}^3$
- Weight = 1.711 kg/m
- Bar length = 6 m
- Packing unit = 36 m

APPLICATIONS

- Combination of construction element and:
- Cable duct
- Guiding groove for belt conveyor
- Storage rail
- Guide for serpentine power chains

ASSEMBLY

- MiniTec power-lock fastener
- closed grooves can be opened with the groove opener **part no. 26.0815/0** to the desired length

COVER PROFILE 45 X 45 R

Part no.

20.1037/0

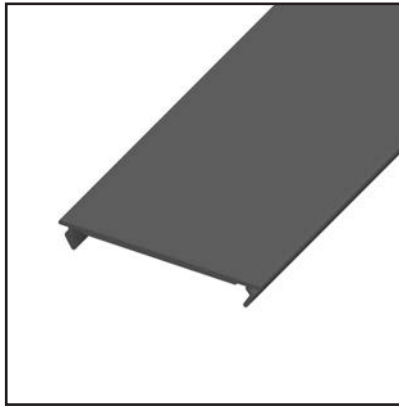
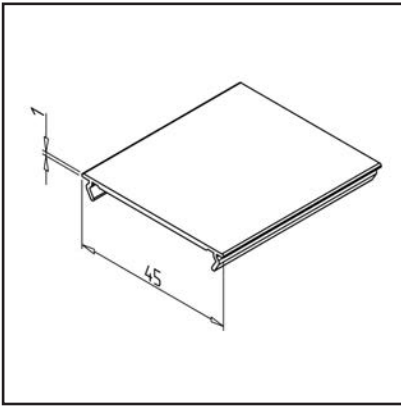

TECHN. DATA / ITEMS SUPPLIED

- PVC, extruded, grey
- Weight = 0.110 kg/m
- Bar length = 2 m

APPLICATIONS

- Covering of profiles 45 x 45 R

ASSEMBLY

- Snaps onto profile

PROFILE HEIGHT ADJUSTMENT

Part no.

20.1143/0

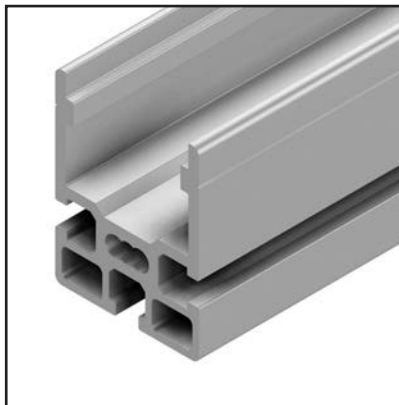
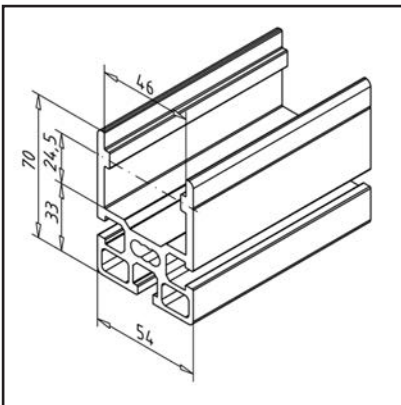

TECHN. DATA / ITEMS SUPPLIED

- Aluminium, extruded, anodized E6/EV1
- $I_x = 40.251 \text{ cm}^4$
- $I_y = 39.822 \text{ cm}^4$
- $w_x = 9.624 \text{ cm}^3$
- $w_y = 14.749 \text{ cm}^3$
- Weight = 2.940 kg/m
- Bar length = 6 m
- Packing unit = 24 m

APPLICATIONS

- Height adjustment
- Telescopic applications

ASSEMBLY

- For clamping or snap-in on the profile in the respective process.

PROFILE 45 R 4

Part no.

20.1120/0

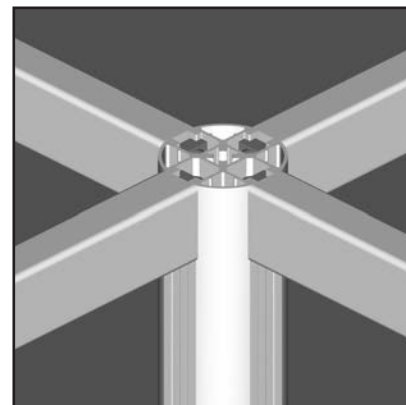
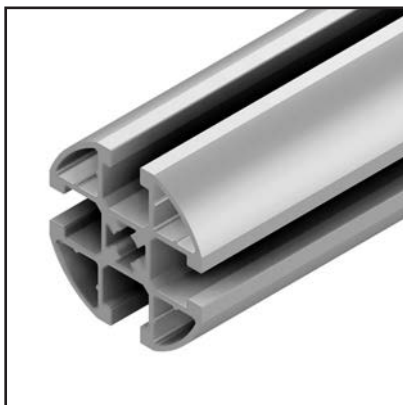
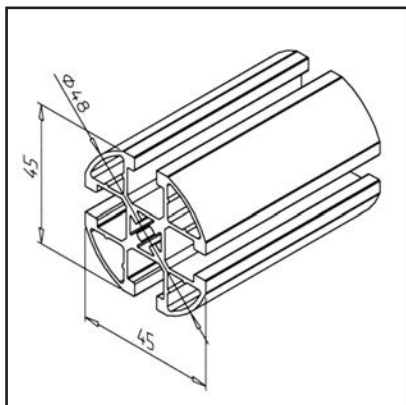
**TECHN. DATA / ITEMS SUPPLIED**

- Aluminium, extruded, anodized E6/EV1
- $I_x = 8.163 \text{ cm}^4$
- $I_y = 8.163 \text{ cm}^4$
- $w_x = 3.628 \text{ cm}^3$
- $w_y = 3.628 \text{ cm}^3$
- Weight = 1.405 kg/m
- Bar length = 6 m
- Packing unit = 48 m

APPLICATIONS

- Weight-optimized constructions
- Handrail
- Connection of profiles 19
- Handles with different length for doors and drawers

ASSEMBLY

- MiniTec power-lock fastener
- Screw connection
- Angle 19 GD-Z, **part no. 21.2078/0**

PROFILE 45 R 90°

Part no.

20.1069/0

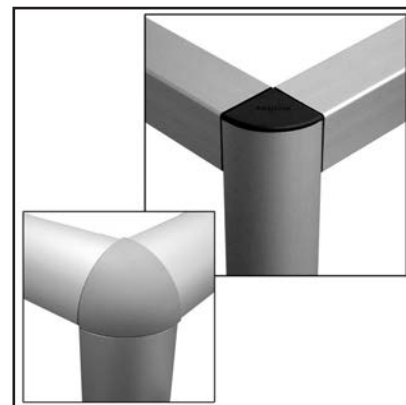
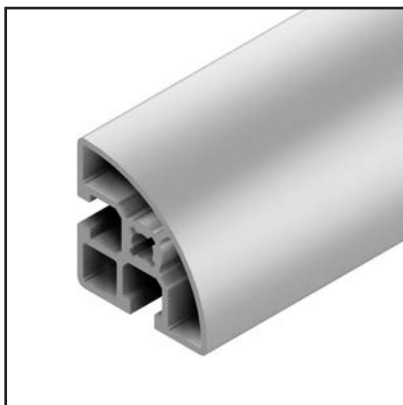
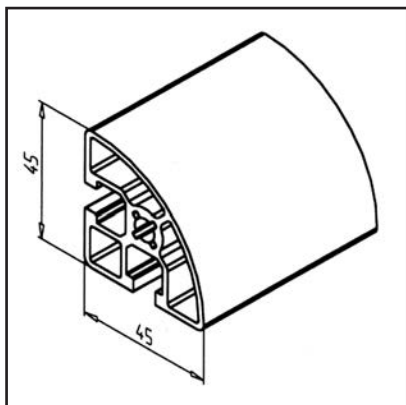
**TECHN. DATA / ITEMS SUPPLIED**

- Aluminium, extruded, anodized E6/EV1
- $I_x = 9.138 \text{ cm}^4$
- $I_y = 9.138 \text{ cm}^4$
- $w_x = 3.581 \text{ cm}^3$
- $w_y = 3.581 \text{ cm}^3$
- Weight = 1.478 kg/m
- Bar length = 6 m
- Packing unit = 48 m

APPLICATIONS

- Weight optimized constructions
- Tables
- Framework constructions
- display windows, showcases

ASSEMBLY

- MiniTec power-lock fastener
- Angle 45 R 90°
- Bolt connector

PROFILE 45 R 60°

Part no.

20.1096/0

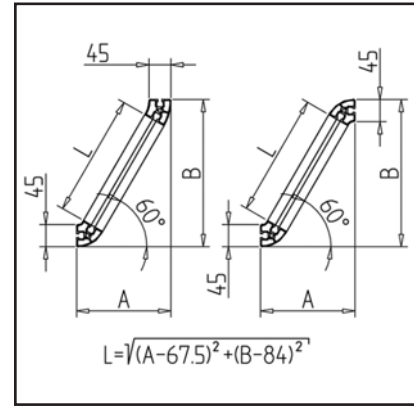
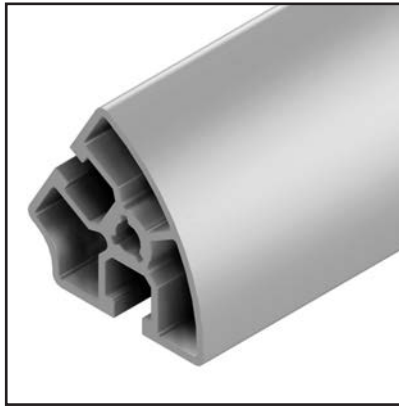
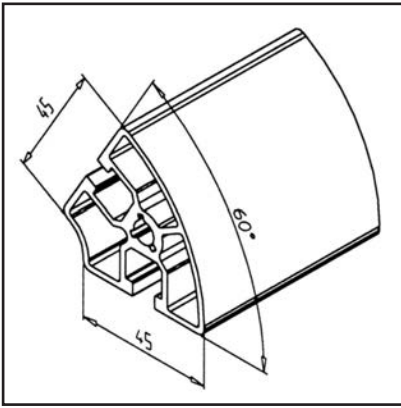

TECHN. DATA / ITEMS SUPPLIED

- Aluminium, extruded, anodized E6/EV1
- $I_x = 11.446 \text{ cm}^4$
- $I_y = 10.28 \text{ cm}^4$
- $w_x = 3.667 \text{ cm}^3$
- $w_y = 3.752 \text{ cm}^3$
- Weight = 1.575 kg/m
- Bar length = 6 m
- Packing unit = 48 m

APPLICATIONS

- Angled enclosures
- Tables
- Framework constructions
- display windows, showcases
- As cross beam:
Calculate dimension L of the intermediate support according to calculating formula

ASSEMBLY

- MiniTec power-lock fastener
- Bolt connector

PROFILE 45 R 45°

Part no.

20.1095/0

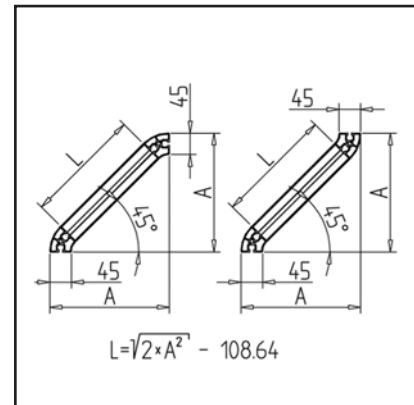
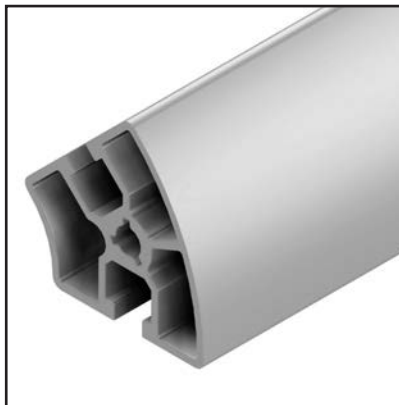
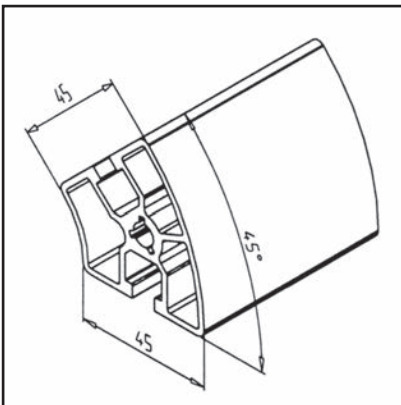

TECHN. DATA / ITEMS SUPPLIED

- Aluminium, extruded, anodized E6/EV1
- $I_x = 12.457 \text{ cm}^4$
- $I_y = 11.296 \text{ cm}^4$
- $w_x = 3.976 \text{ cm}^3$
- $w_y = 3.837 \text{ cm}^3$
- Weight = 1.607 kg/m
- Bar length = 6 m
- Packing unit = 48 m

APPLICATIONS

- Angled enclosures
- Tables
- Framework constructions
- display windows, showcases
- As cross beam:
Calculate dimension L of the intermediate support according to calculating formula

ASSEMBLY

- MiniTec power-lock fastener
- Bolt connector

PROFILE 45 R 30°

Part no.

20.1094/0

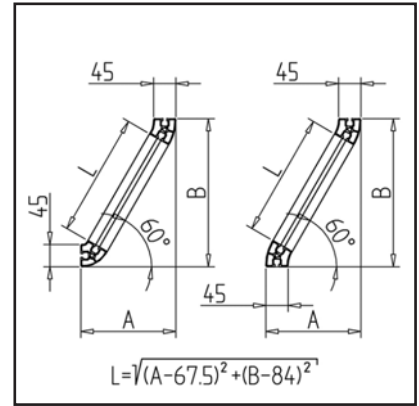
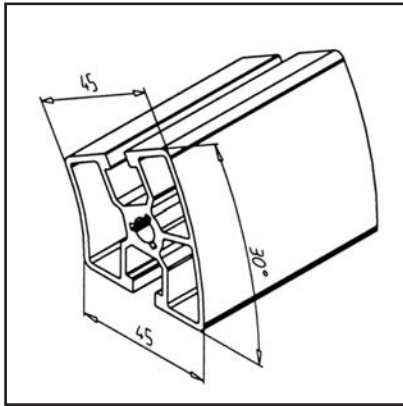

TECHN. DATA / ITEMS SUPPLIED

- Aluminium, extruded, anodized E6/EV1
- $I_x = 12.138 \text{ cm}^4$
- $I_y = 11.006 \text{ cm}^4$
- $w_x = 4.018 \text{ cm}^3$
- $w_y = 3.883 \text{ cm}^3$
- Weight = 1.626 kg/m
- Bar length = 6 m
- Packing unit = 48 m

APPLICATIONS

- Angled enclosures
- Tables
- Framework constructions
- display windows, showcases
- As cross beam:
Calculate dimension L of the intermediate support according to calculating formula

ASSEMBLY

- MiniTec power-lock fastener
- Bolt connector

PROFILE 45 / 45°

Part no.

20.1029/0

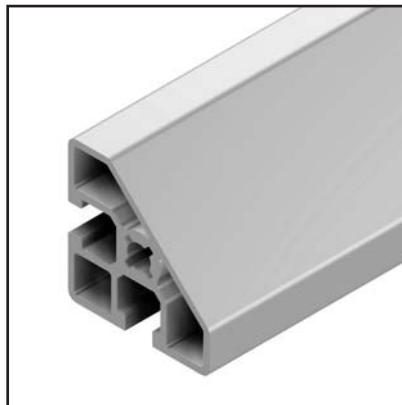
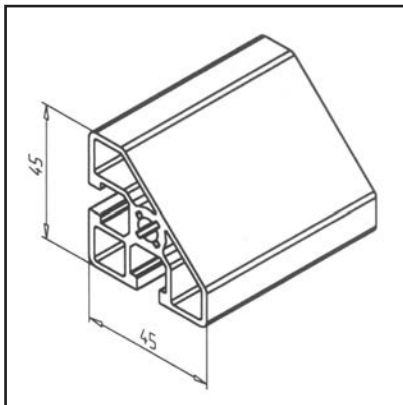

TECHN. DATA / ITEMS SUPPLIED

- Aluminium, extruded, anodized E6/EV1
- $I_x = 8.626 \text{ cm}^4$
- $I_y = 8.626 \text{ cm}^4$
- $w_x = 3.315 \text{ cm}^3$
- $w_y = 3.315 \text{ cm}^3$
- Weight = 1.443 kg/m
- Bar length = 6 m
- Packing unit = 48 m

APPLICATIONS

- Weight optimized constructions
- Tables
- Framework constructions
- Bracings

ASSEMBLY

- MiniTec power-lock fastener
- Angle 45°
- Mounting bracket 45 or 90
- Bolt connector

PROFILE 45 / 22,5°

Part no.

20.1030/0

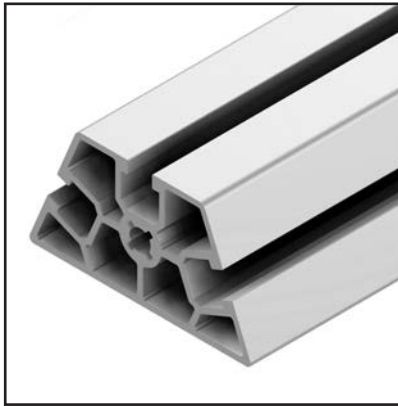
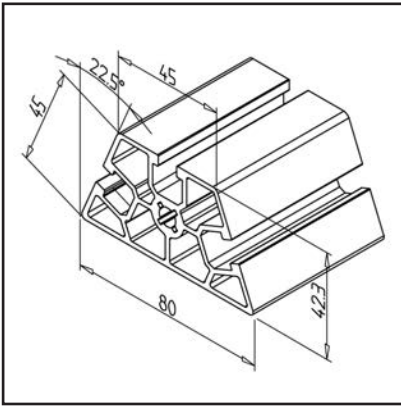

TECHN. DATA / ITEMS SUPPLIED

- Aluminium, extruded, anodized E6/EV1
- $I_x = 14.506 \text{ cm}^4$
- $I_y = 33.432 \text{ cm}^4$
- $w_x = 7.934 \text{ cm}^3$
- $w_y = 8.515 \text{ cm}^3$
- Weight = 2.225 kg/m
- Bar length = 6 m
- Packing unit = 36 m

APPLICATIONS

- Guard units
- Tables
- Connection of construction elements at an angle of 45°
- Bracings

ASSEMBLY

- MiniTec power-lock fastener
- Angles
- Bolt connector

PROFILE 19 X 90

Part no.

20.0995/0

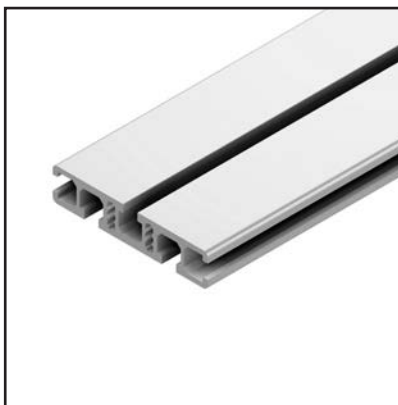
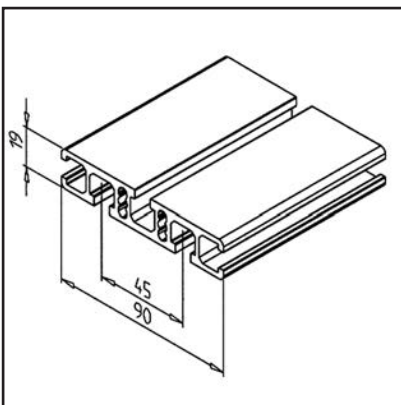

TECHN. DATA / ITEMS SUPPLIED

- Aluminium, extruded, anodized E6/EV1
- $I_x = 3.436 \text{ cm}^4$
- $I_y = 45.455 \text{ cm}^4$
- $w_x = 3.493 \text{ cm}^3$
- $w_y = 10.101 \text{ cm}^3$
- Weight = 1.919 kg/m
- Bar length = 6 m
- Packing unit = 48 m

APPLICATIONS

- Base plates, tensioning plates
- Contact areas
- Slide plates for linear slides
- Floor fastening plates
- Showcases

ASSEMBLY

- Bolt connector
- Angles

PROFILE 90 X 32 UL

Part no.

20.1066/0

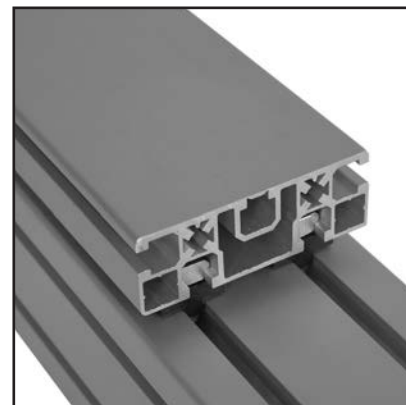
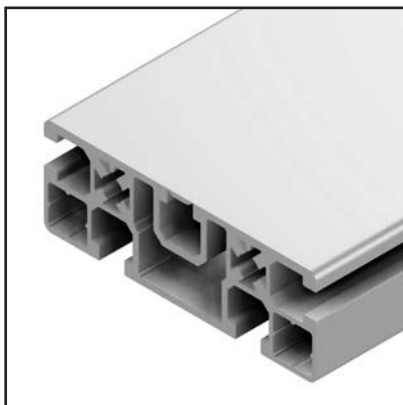
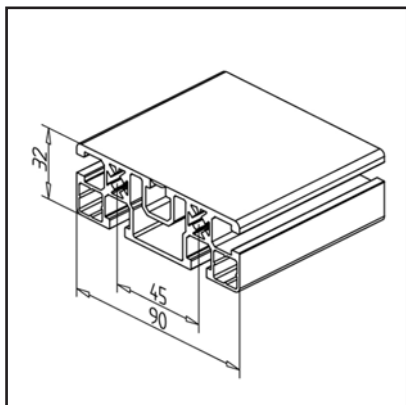

TECHN. DATA / ITEMS SUPPLIED

- Aluminium, extruded, anodized E6/EV1
- $I_x = 10.627 \text{ cm}^4$
- $I_y = 64.889 \text{ cm}^4$
- $w_x = 5.832 \text{ cm}^3$
- $w_y = 14.34 \text{ cm}^3$
- Weight = 2.464 kg/m
- Bar length = 6 m
- Packing unit = 36 m

APPLICATIONS

- All types of constructions, with a closed profile side
- Weight-optimized constructions
- Tables
- Frames
- Safety equipment

ASSEMBLY

- MiniTec power-lock fastener
- Angles
- Screw connection
- closed grooves can be opened with the groove opener **part no. 26.0815/0** to the desired length

PROFILE 45 X 90 UL

Part no.

20.1067/0

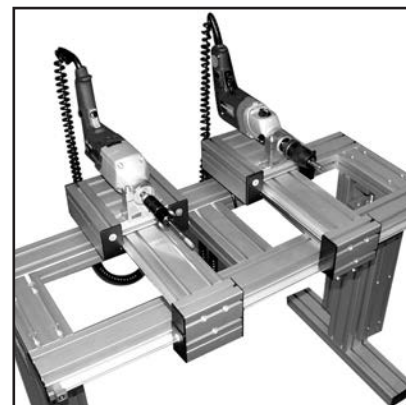
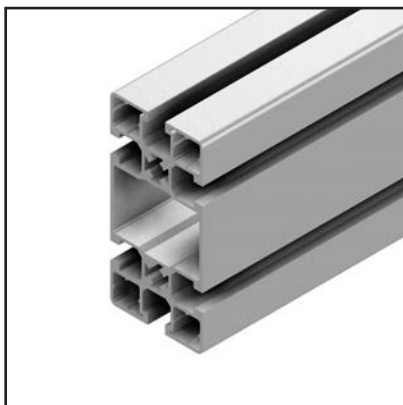
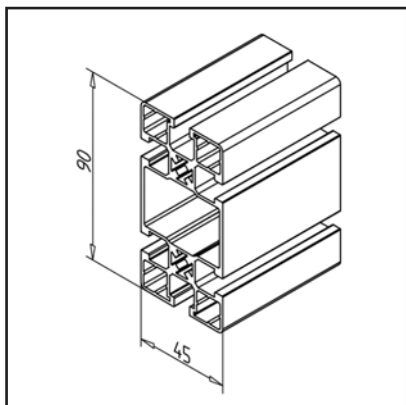

TECHN. DATA / ITEMS SUPPLIED

- Aluminium, extruded, anodized E6/EV1
- $I_x = 73.907 \text{ cm}^4$
- $I_y = 19.194 \text{ cm}^4$
- $w_x = 16.423 \text{ cm}^3$
- $w_y = 8.53 \text{ cm}^3$
- Weight = 2.421 kg/m
- Bar length = 6 m
- Packing unit = 24 m

APPLICATIONS

- Universal mounting for all types of weight optimised constructions
- The hollow chamber is designed for receiving and guiding counterweights

ASSEMBLY

- MiniTec power-lock fastener
- Angle 19 / 25 / 45 / 45 x 90 GD-Z
- Bolt connector
- Screw connection

PROFIL 45 X 90 F

Part no.

20.1032/0

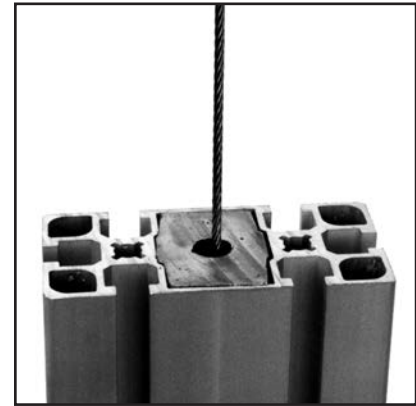
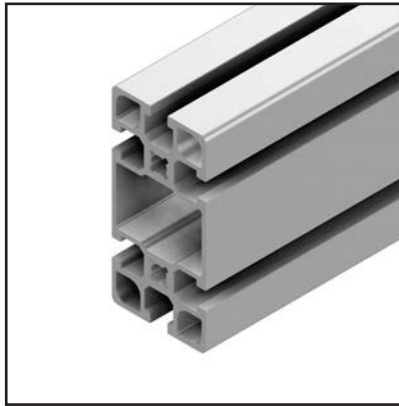
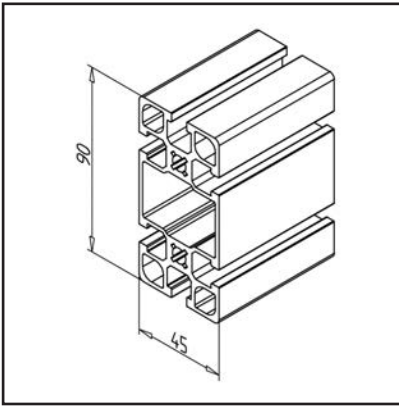

TECHN. DATA / ITEMS SUPPLIED

- Aluminium, extruded, anodized E6/EV1
- $I_x = 100.988 \text{ cm}^4$
- $I_y = 24.34 \text{ cm}^4$
- $w_x = 22.441 \text{ cm}^3$
- $w_y = 10.818 \text{ cm}^3$
- Weight = 3.134 kg/m
- Bar length = 6 m
- Packing unit = 24 m

APPLICATIONS

- General constructions
- The hollow chamber is designed for receiving and guiding counterweights

ASSEMBLY

- MiniTec power-lock fastener
- Angle 19 / 25 / 45 / 45 x 90 GD-Z
- Bolt connector

PROFILE 45 X 90

Part no.

20.1009/0

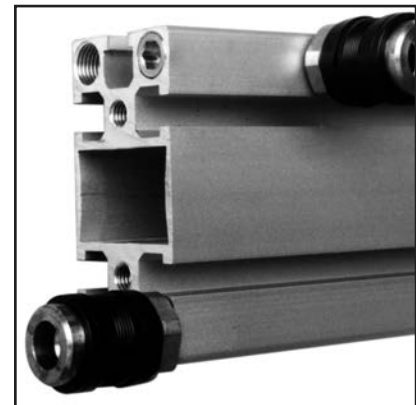
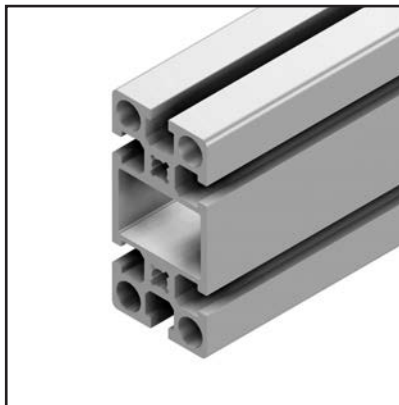
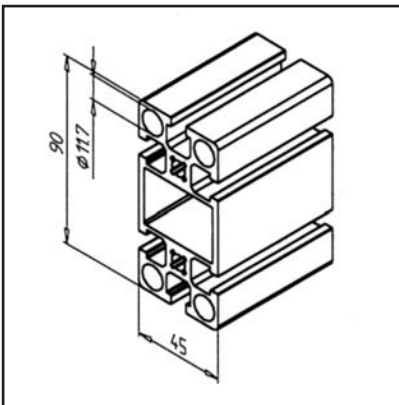

TECHN. DATA / ITEMS SUPPLIED

- Aluminium, extruded, anodized E6/EV1
- $I_x = 113.205 \text{ cm}^4$
- $I_y = 28.584 \text{ cm}^4$
- $w_x = 25.156 \text{ cm}^3$
- $w_y = 12.704 \text{ cm}^3$
- Weight = 3.667 kg/m
- Bar length = 6 m
- Packing unit = 24 m

APPLICATIONS

- General heavy duty construction
- 4 cavities for compressed air piping
- Cavity is not suitable for counterweights

ASSEMBLY

- MiniTec power-lock fastener
- Angle 25 / 45 / 90
- Bolt connector
- The $\varnothing 11.7 \text{ mm}$ holes can be bored with G 1/4 for holding screw plugs or pneumatic connections
- Lateral connections G 1/8" direct into the profile

PROFILE 45 X 90 S

Part no.

20.1017/0

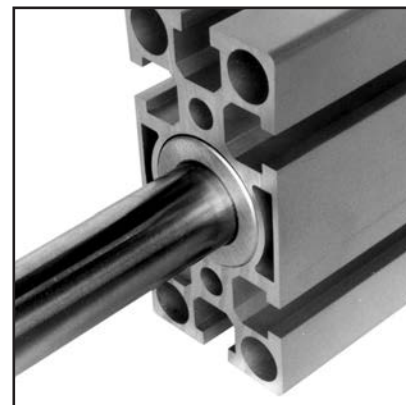
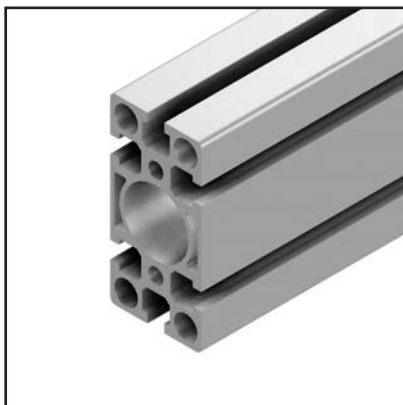
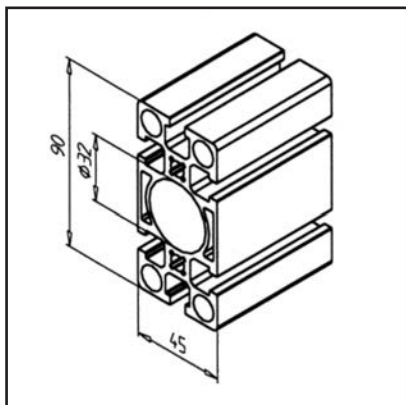

TECHN. DATA / ITEMS SUPPLIED

- Aluminium, extruded, anodized E6/EV1
- $I_x = 113.487 \text{ cm}^4$
- $I_y = 30.719 \text{ cm}^4$
- $w_x = 25.219 \text{ cm}^3$
- $w_y = 13.653 \text{ cm}^3$
- Weight = 3.860 kg/m
- Bar length = 6 m
- Packing unit = 24 m

APPLICATIONS

- All kinds of constructions
- Linear guides LB as slide
- Column guides
- Implementation as compressed air line with base and transport plate and sealing set
- Central bore $\varnothing 32 \text{ mm}$ for ball-bushings LME 20, for ball-bearings 6201 or 6002, for compressed air piping or guiding of hydraulic add-in cylinders

ASSEMBLY

- MiniTec power-lock fastener
- Mounting bracket 45 or 90
- Screw connection

PROFILE 45 X 90 G

Part no.

20.1015/0

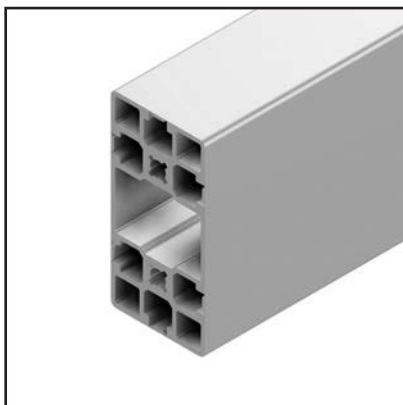
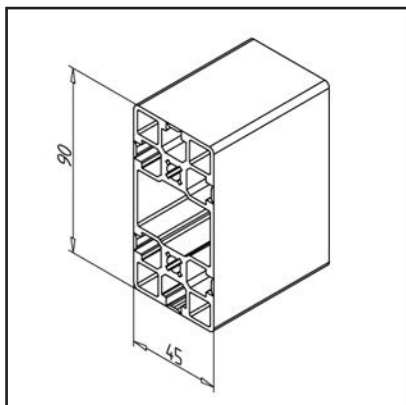

TECHN. DATA / ITEMS SUPPLIED

- Aluminium, extruded, anodized E6/EV1
- $I_x = 101.241 \text{ cm}^4$
- $I_y = 25.318 \text{ cm}^4$
- $w_x = 22.498 \text{ cm}^3$
- $w_y = 11.252 \text{ cm}^3$
- Weight = 3.191 kg/m
- Bar length = 6 m
- Packing unit = 24 m

APPLICATIONS

- All types of constructions, specifically for high hygiene requirements in the food industry, medical technology, bottling of beverages
- Guide for internal counterweights in a central hollow chamber

ASSEMBLY

- MiniTec power-lock fastener
- All 6 grooves can be opened up to the length desired
- closed grooves can be opened with the groove opener **part no. 26.0815/0** to the desired length

PROFILE 45 X 90 2 G

Part no.

20.1081/0

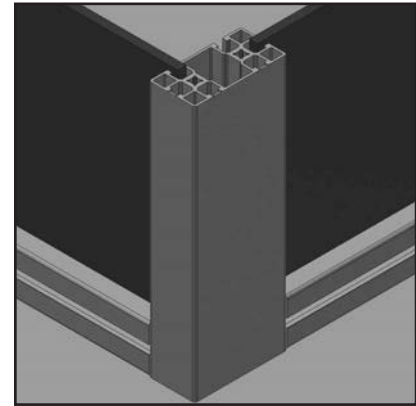
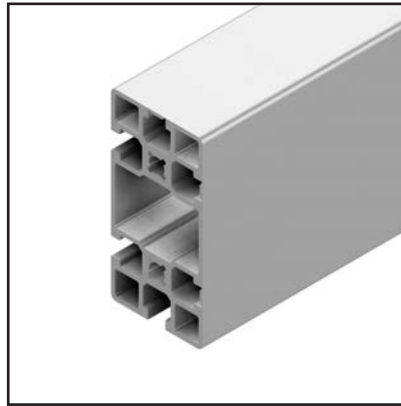
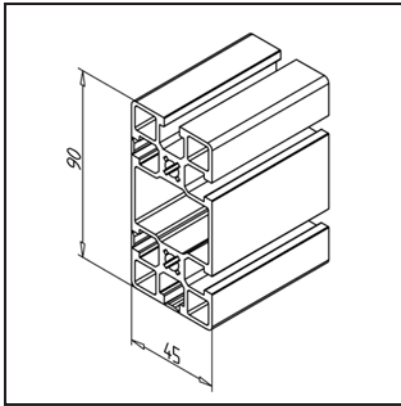

TECHN. DATA / ITEMS SUPPLIED

- Aluminium, extruded, anodized E6/EV1
- $I_x = 98.137 \text{ cm}^4$
- $I_y = 24.317 \text{ cm}^4$
- $w_x = 21.808 \text{ cm}^3$
- $w_y = 10.807 \text{ cm}^3$
- Weight = 3.108 kg/m
- Bar length = 6 m
- Packing unit = 24 m

APPLICATIONS

- Grooves expandable
- All types of constructions, specifically for high hygiene requirements in the food industry, medical technology, bottling of beverages
- Guide for internal counterweights in a central hollow chamber

ASSEMBLY

- MiniTec power-lock fastener
- closed grooves can be opened with the groove opener **part no. 26.0815/0** to the desired length

PROFIL 90 X 90 X 45

Part no.

20.0984/0

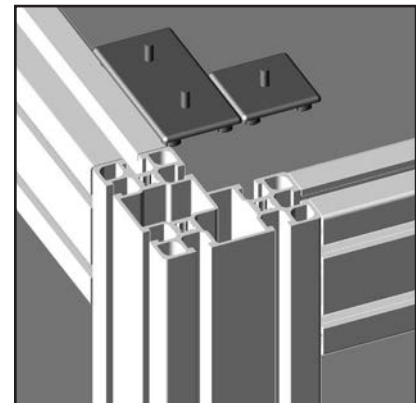
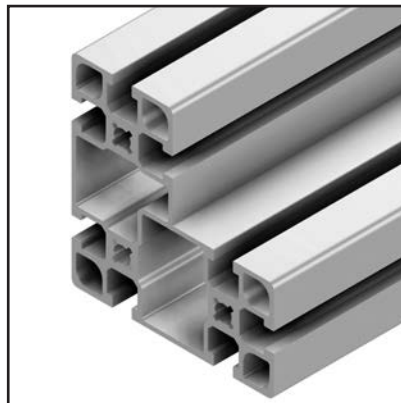
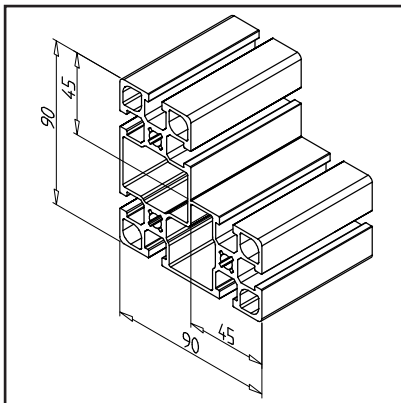

TECHN. DATA / ITEMS SUPPLIED

- Aluminium, extruded, anodized E6/EV1
- $I_x = 127.588 \text{ cm}^4$
- $I_y = 127.459 \text{ cm}^4$
- $w_x = 24.971 \text{ cm}^3$
- $w_y = 24.895 \text{ cm}^3$
- Weight = 4.458 kg/m
- Bar length = 6 m
- Packing unit = 12 m

APPLICATIONS

- All kinds of constructions
- Tables
- display windows, showcases
- Framework constructions
- One chamber can be used to guide counterweight 45

ASSEMBLY

- MiniTec power-lock fastener
- Screw connection
- Mounting bracket 45 or 90
- Base and transport plate 90x90x45 **part no. 21.2505/0**

PROFILE 45 X 60 F

Part no.

20.1023/0

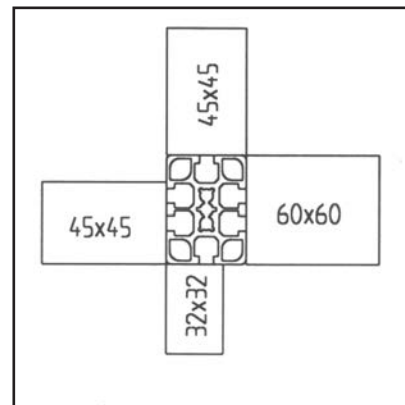
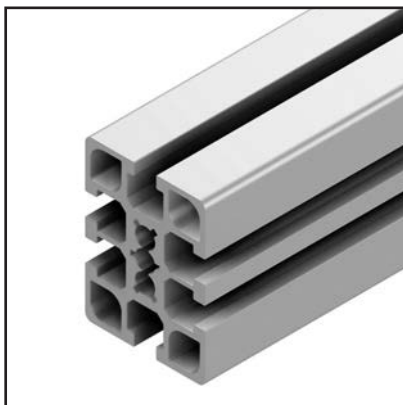
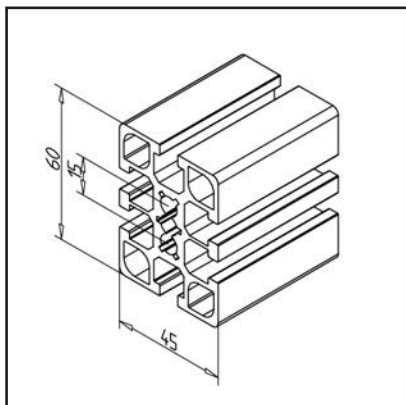
**TECHN. DATA / ITEMS SUPPLIED**

- Aluminium, extruded, anodized E6/EV1
- $I_x = 32.068 \text{ cm}^4$
- $I_y = 17.587 \text{ cm}^4$
- $w_x = 10.689 \text{ cm}^3$
- $w_y = 7.816 \text{ cm}^3$
- Weight = 2.603 kg/m
- Bar length = 6 m
- Packing unit = 24 m

APPLICATIONS

- General constructions
- Corner posts in large safety devices

ASSEMBLY

- MiniTec power-lock fastener
- Angle 19 / 25 / 45 / 45 x 90 GD-Z
- Central boring for thread M8

PROFILE 60 X 60 F

Part no.

20.1049/0

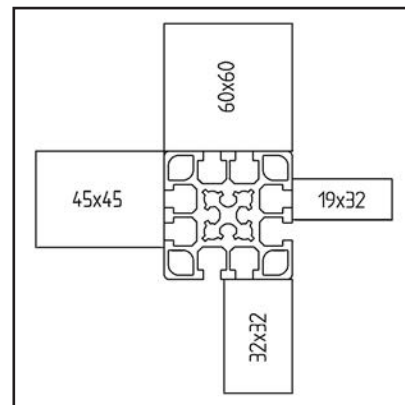
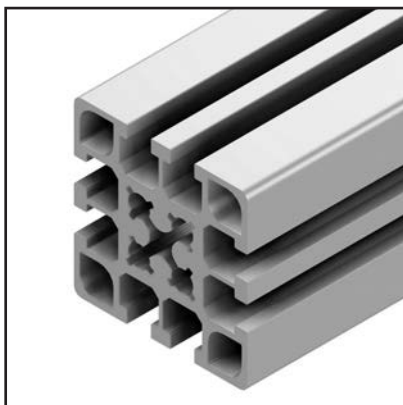
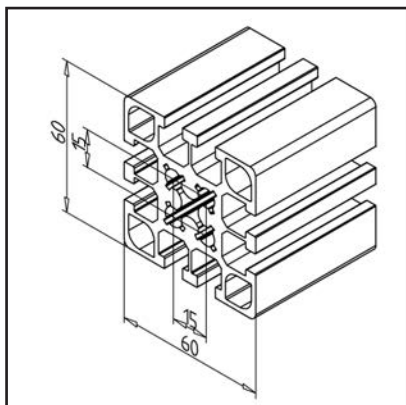
**TECHN. DATA / ITEMS SUPPLIED**

- Aluminium, extruded, anodized E6/EV1
- $I_x = 40.715 \text{ cm}^4$
- $I_y = 40.715 \text{ cm}^4$
- $w_x = 13.571 \text{ cm}^3$
- $w_y = 13.571 \text{ cm}^3$
- Weight = 3.655 kg/m
- Bar length = 6 m
- Packing unit = 24 m

APPLICATIONS

- General constructions
- Corner posts in large safety devices

ASSEMBLY

- MiniTec power-lock fastener
- Angle 19 / 25 / 45 / 45 x 90 GD-Z
- Central boring for thread M10

PROFILE 45 X 135 F

Part no.

20.1087/0

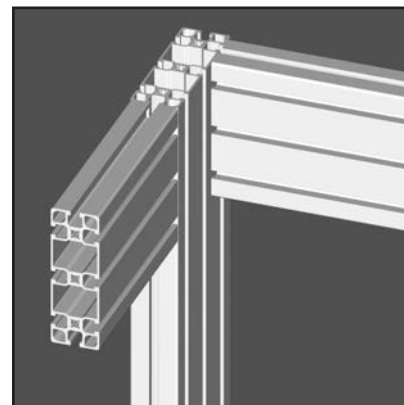
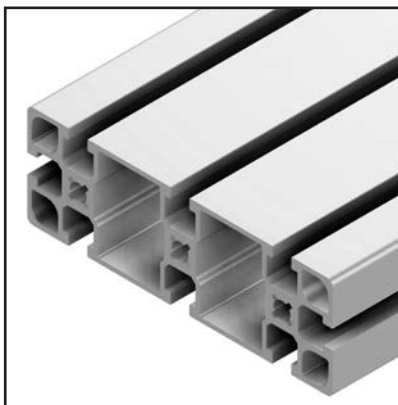
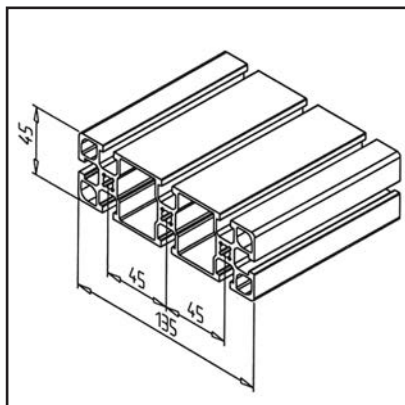

TECHN. DATA / ITEMS SUPPLIED

APPLICATIONS

ASSEMBLY

- Aluminium, extruded, anodized E6/EV1
- $I_x = 34.958 \text{ cm}^4$
- $I_y = 307.866 \text{ cm}^4$
- $w_x = 15.537 \text{ cm}^3$
- $w_y = 45.609 \text{ cm}^3$
- Weight = 4.319 kg/m
- Bar length = 6 m
- Packing unit = 12 m

- General constructions
- The hollow chamber is designed for receiving and guiding counterweights

- MiniTec power-lock fastener
- Angle 19 / 25 / 45 / 45 x 90 GD-Z
- Bolt connector

PROFILE 45 X 135 1G

Part no.

20.1078/0

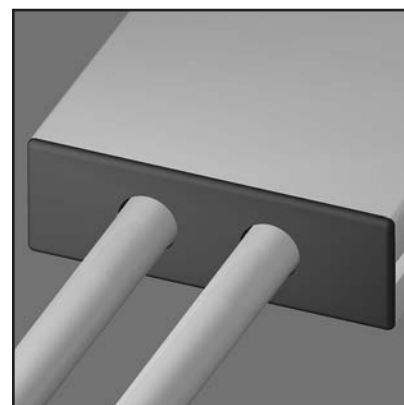
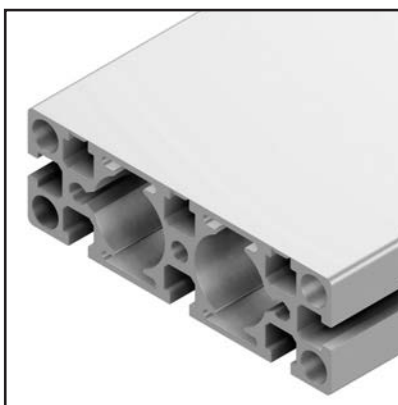
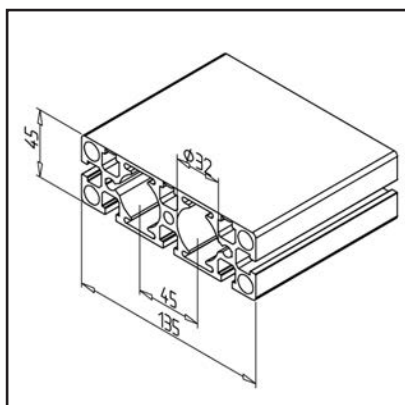

TECHN. DATA / ITEMS SUPPLIED

APPLICATIONS

ASSEMBLY

- Aluminium, extruded, anodized E6/EV1
- $I_x = 47.064 \text{ cm}^4$
- $I_y = 359.242 \text{ cm}^4$
- $w_x = 20.618 \text{ cm}^3$
- $w_y = 53.221 \text{ cm}^3$
- Weight = 5.570 kg/m
- Bar length = 6 m
- Packing unit = 12 m

- All types of constructions, specifically for high hygiene requirements in the food industry, medical technology, bottling of beverages
- Linear guides LB as slide
- Central bore $\varnothing 32$ mm for ball-bushings LME 20, for ball-bearings 6201 or 6002, for compressed air piping or guiding of hydraulic add-in cylinders

- MiniTec power-lock fastener
- closed grooves can be opened with the groove opener **part no. 26.0815/0** to the desired length

PROFILE 45 X 180 1G

Part no.

20.1079/0

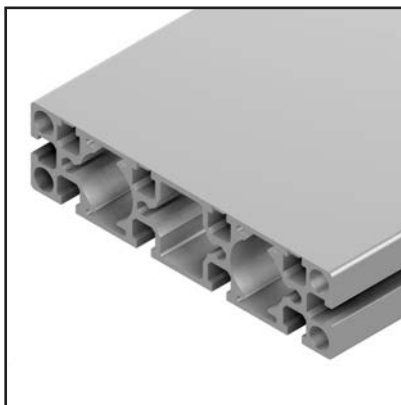
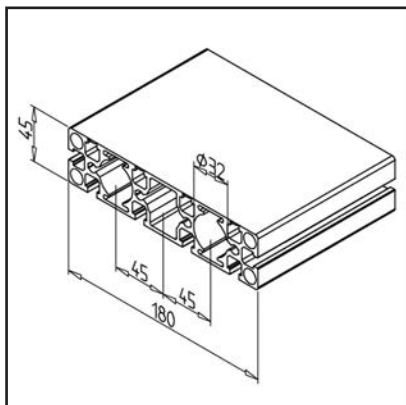
**TECHN. DATA / ITEMS SUPPLIED**

- Aluminium, extruded, anodized E6/EV1
- $I_x = 61.015 \text{ cm}^4$
- $I_y = 810.885 \text{ cm}^4$
- $w_x = 26.704 \text{ cm}^3$
- $w_y = 90.097 \text{ cm}^3$
- Weight = 6.950 kg/m
- Bar length = 6 m
- Packing unit = 12 m

APPLICATIONS

- All types of constructions, specifically for high hygiene requirements in the food industry, medical technology, bottling of beverages
- Linear guides LB as slide
- Central bore $\varnothing 32$ mm for ball-bushings LME 20, for ball-bearings 6201 or 6002, for compressed air piping or guiding of hydraulic add-in cylinders

ASSEMBLY

- MiniTec power-lock fastener
- closed grooves can be opened with the groove opener **part no. 26.0815/0** to the desired length

PROFILE 90 X 90 UL

Part no.

20.0999/0

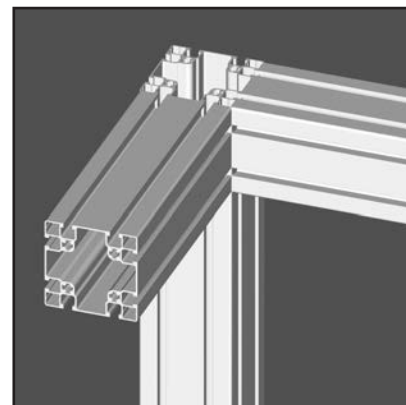
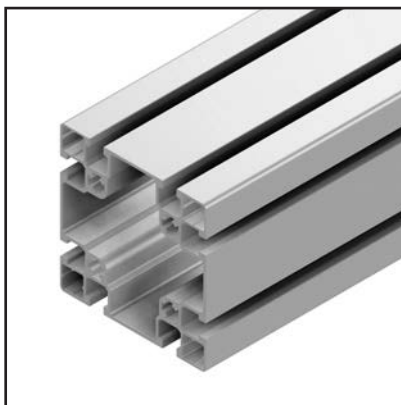
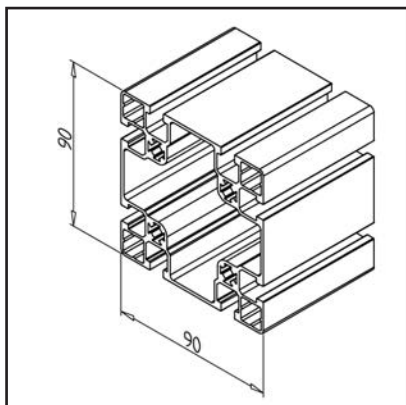
**TECHN. DATA / ITEMS SUPPLIED**

- Aluminium, extruded, anodized E6/EV1
- $I_x = 132.001 \text{ cm}^4$
- $I_y = 132.001 \text{ cm}^4$
- $w_x = 29.334 \text{ cm}^3$
- $w_y = 29.334 \text{ cm}^3$
- Weight = 3.776 kg/m
- Bar length = 6 m
- Packing unit = 12 m

APPLICATIONS

- Weight optimized constructions
- Guide in the central hollow chamber for internal balancing weight for lifting doors

ASSEMBLY

- MiniTec power-lock fastener
- Mounting bracket 45 or 90
- Screw connection
- Bolt connector

PROFILE 90 X 90 L

Part no.

20.1010/0

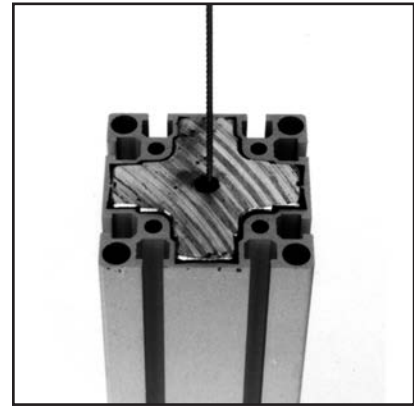
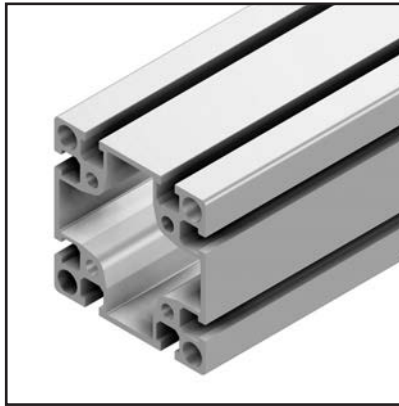
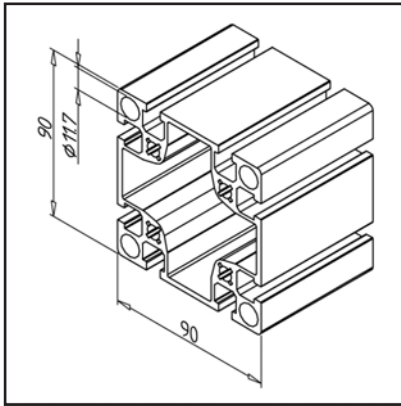

TECHN. DATA / ITEMS SUPPLIED

- Aluminium, extruded, anodized E6/EV1
- $I_x = 186.26 \text{ cm}^4$
- $I_y = 186.26 \text{ cm}^4$
- $w_x = 41.391 \text{ cm}^3$
- $w_y = 41.391 \text{ cm}^3$
- Weight = 5.222 kg/m
- Bar length = 6 m
- Packing unit = 12 m

APPLICATIONS

- All types of heavy constructions, designed as 4-fold compressed air line and compressed air reservoir
- Guide in the central hollow chamber for internal balancing weight for lifting doors

ASSEMBLY

- MiniTec power-lock fastener
- Mounting bracket 45 or 90
- Screw connection
- Bolt connector

PROFILE 90 X 90 S

Part no.

20.1019/0

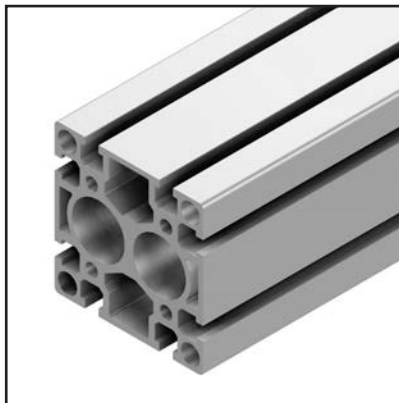
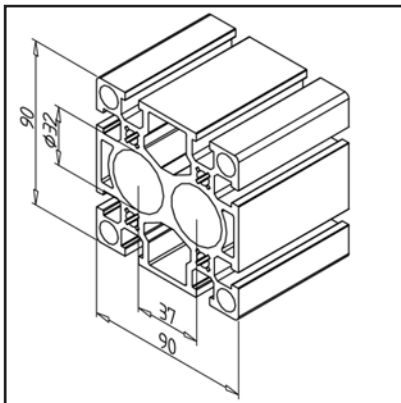

TECHN. DATA / ITEMS SUPPLIED

- Aluminium, extruded, anodized E6/EV1
- $I_x = 208.888 \text{ cm}^4$
- $I_y = 223.949 \text{ cm}^4$
- $w_x = 46.419 \text{ cm}^3$
- $w_y = 49.766 \text{ cm}^3$
- Weight = 7.514 kg/m
- Bar length = 6 m
- Packing unit = 12 m

APPLICATIONS

- All types of heavy constructions
- Linear guides LB as slide
- Central bore $\text{Ø } 32 \text{ mm}$ for ball-bushings LME 20, for ball-bearings 6201 or 6002, for compressed air piping or guiding of hydraulic add-in cylinders

ASSEMBLY

- MiniTec power-lock fastener
- Mounting bracket 45 or 90
- Screw connection

PROFILE 90 X 90 G

Part no.

20.1082/0

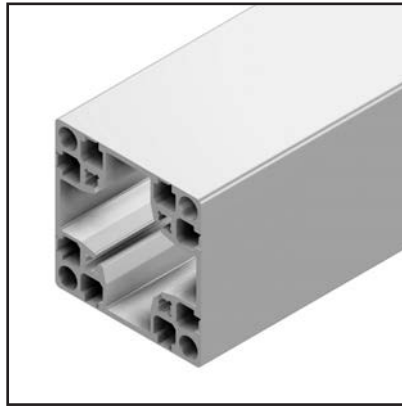
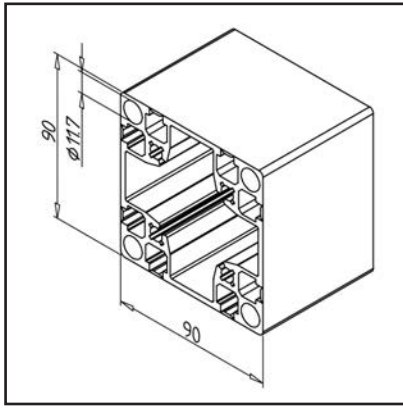
**TECHN. DATA / ITEMS SUPPLIED**

- Aluminium, extruded, anodized E6/EV1
- $I_x = 195.271 \text{ cm}^4$
- $I_y = 195.271 \text{ cm}^4$
- $w_x = 43.393 \text{ cm}^3$
- $w_y = 43.393 \text{ cm}^3$
- Weight = 5.329 kg/m
- Bar length = 6 m
- Packing unit = 12 m

APPLICATIONS

- Grooves expandable
- All types of constructions, specifically for high hygiene requirements in the food industry, medical technology, bottling of beverages
- Guide for internal counterweights in a central hollow chamber

ASSEMBLY

- MiniTec power-lock fastener
- closed grooves can be opened with the groove opener **part no. 26.0815/0** to the desired length

PROFILE 90 X 90 2 G

Part no.

20.1044/0

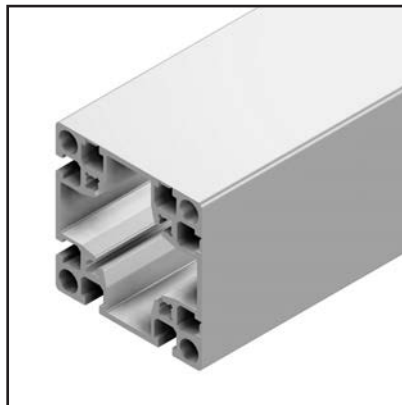
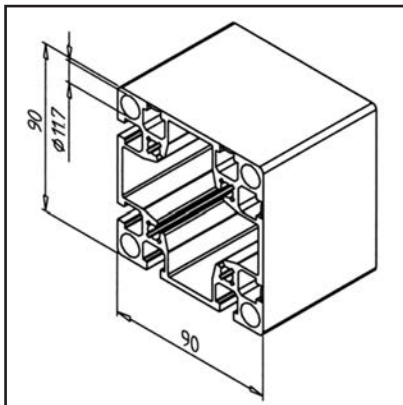
**TECHN. DATA / ITEMS SUPPLIED**

- Aluminium, extruded, anodized E6/EV1
- $I_x = 190.169 \text{ cm}^4$
- $I_y = 190.169 \text{ cm}^4$
- $w_x = 41.825 \text{ cm}^3$
- $w_y = 41.825 \text{ cm}^3$
- Weight = 5.217 kg/m
- Bar length = 6 m
- Packing unit = 12 m

APPLICATIONS

- Grooves expandable
- All types of constructions, specifically for high hygiene requirements in the food industry, medical technology, bottling of beverages
- Guide for internal counterweights in a central hollow chamber

ASSEMBLY

- MiniTec power-lock fastener
- closed grooves can be opened with the groove opener **part no. 26.0815/0** to the desired length

PROFILE 90 R 90°

Part no.

20.1091/0

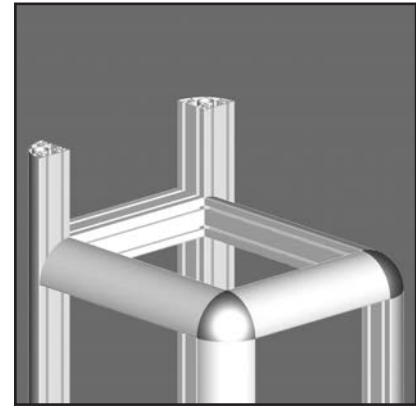
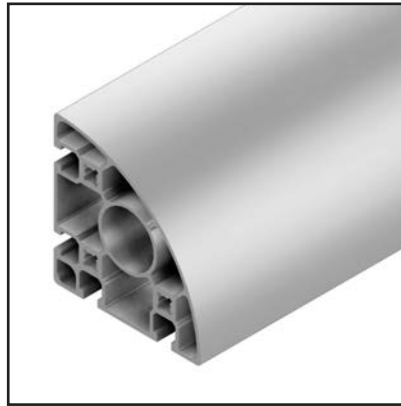
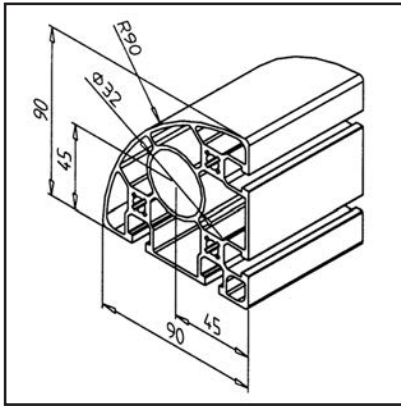

TECHN. DATA / ITEMS SUPPLIED

- Aluminium, extruded, anodized E6/EV1
- $I_x = 113.389 \text{ cm}^4$
- $I_y = 113.389 \text{ cm}^4$
- $w_x = 21.874 \text{ cm}^3$
- $w_y = 21.874 \text{ cm}^3$
- Weight = 4.265 kg/m
- Bar length = 6 m
- Packing unit = 12 m

APPLICATIONS

- Tables, frames
- All kinds of constructions

ASSEMBLY

- MiniTec power-lock fastener
- Angles
- Bolt connector
- End cap, **part no. 22.1021/1**
- Connecting plate M10 - M20
- Corner Connection 90 R 90°

PROFILE 32 X 180

Part no.

20.1016/0

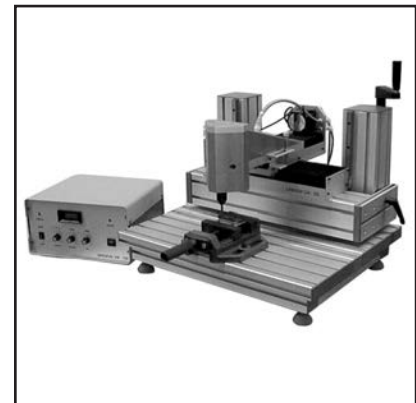
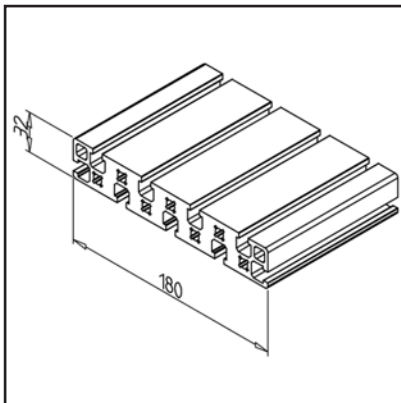

TECHN. DATA / ITEMS SUPPLIED

- Aluminium, extruded, anodized E6/EV1
- $I_x = 33.804 \text{ cm}^4$
- $I_y = 843.825 \text{ cm}^4$
- $w_x = 21.068 \text{ cm}^3$
- $w_y = 93.758 \text{ cm}^3$
- Weight = 9.539 kg/m
- Bar length = 6 m
- Packing unit = 6 m

APPLICATIONS

- Slide plate LR
- Tensioning area
- Base plates
- All types of heavy constructions

ASSEMBLY

- MiniTec power-lock fastener
- Mounting bracket 45 or 90
- Screw connection

PROFIL 90 X 135

Part no.

20.1148/0

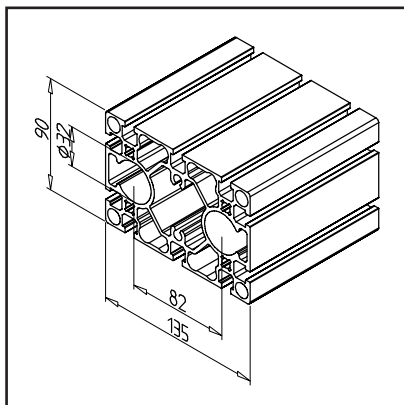
**TECHN. DATA / ITEMS SUPPLIED**

- Aluminium, extruded, anodized E6/EV1
- $I_x = 286.480 \text{ cm}^4$
- $I_y = 631.058 \text{ cm}^4$
- $w_x = 63.662 \text{ cm}^3$
- $w_y = 93.490 \text{ cm}^3$
- Weight = 8.992 kg/m
- Bar length = 6 m
- Packing unit = 6 m

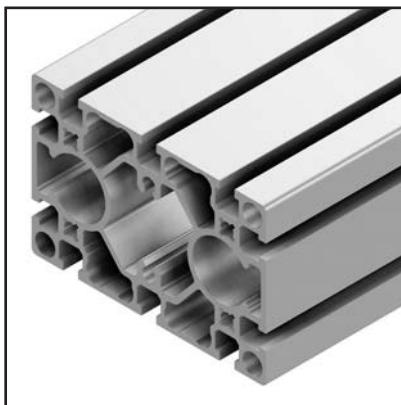
**APPLICATIONS**

- Central bore $\varnothing 32$ mm for ball-bushings LME 20, for ball-bearings 6201 or 6002, for compressed air piping or guiding of hydraulic add-in cylinders
- Linear guides LB as slide
- All types of heavy constructions

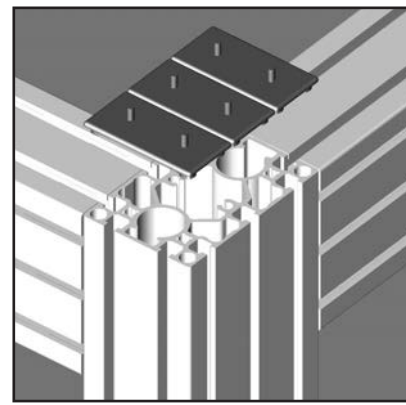
**ASSEMBLY**

- Screw connection
- MiniTec power-lock fastener
- Mounting bracket 45 or 90

PROFILE 90 X 180 S

Part no.

20.1013/0

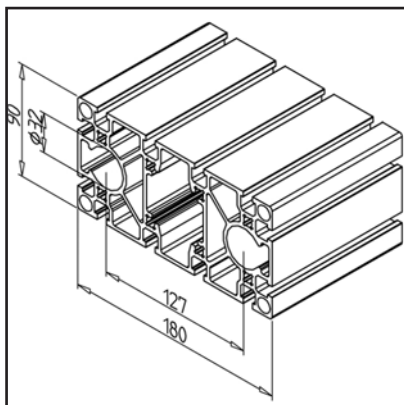
**TECHN. DATA / ITEMS SUPPLIED**

- Aluminium, extruded, anodized E6/EV1
- $I_x = 376.784 \text{ cm}^4$
- $I_y = 1421.865 \text{ cm}^4$
- $w_x = 83.729 \text{ cm}^3$
- $w_y = 157.983 \text{ cm}^3$
- Weight = 11.482 kg/m
- Bar length = 6 m
- Packing unit = 6 m

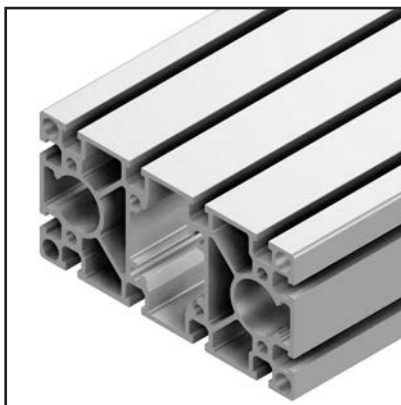
**APPLICATIONS**

- All types of heavy constructions
- Linear guides LB as slide
- Central bore $\varnothing 32$ mm for ball-bushings LME 20, for ball-bearings 6201 or 6002, for compressed air piping or guiding of hydraulic add-in cylinders

**ASSEMBLY**

- MiniTec power-lock fastener
- Mounting bracket 45 or 90
- Screw connection

PROFILE 270 X 19

Part no.

20.1077/0

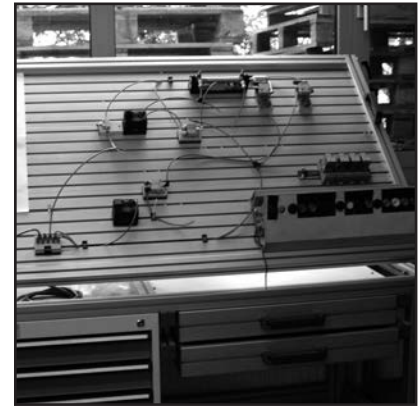
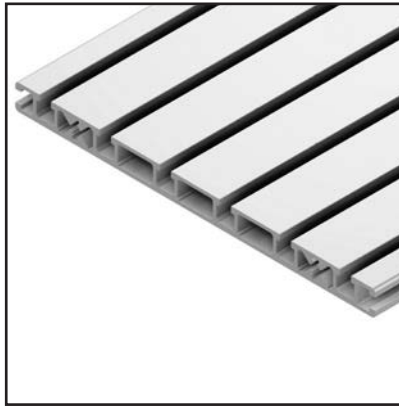
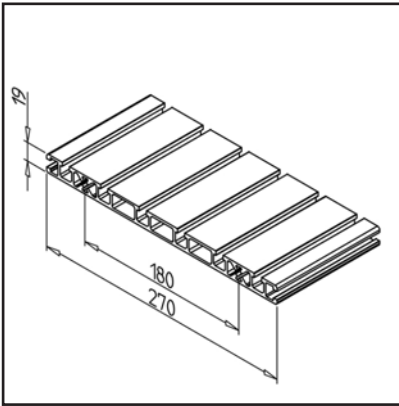

TECHN. DATA / ITEMS SUPPLIED

- Aluminium, extruded, anodized E6/EV1
- $I_x = 10.348 \text{ cm}^4$
- $I_y = 1352.197 \text{ cm}^4$
- $w_x = 10.167 \text{ cm}^3$
- $w_y = 100.162 \text{ cm}^3$
- Weight = 5.612 kg/m
- Bar length = 6 m
- Packing unit = 18 m

APPLICATIONS

- Mounting plates
- Workstations
- Training set-ups for training and further education with universal clamping base **part no. P2.0060/0**
- Demonstration units

ASSEMBLY

- MiniTec power-lock fastener
- Screw connection
- Bolt connector

HANDLE PROFILE ALUMINIUM

Part no.

20.1045/0

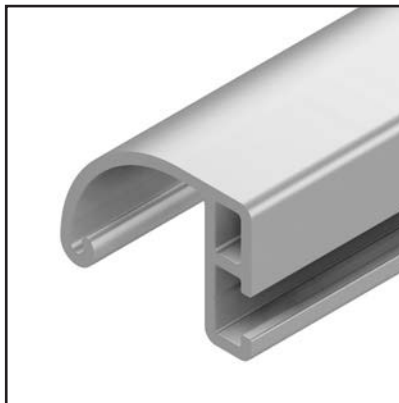
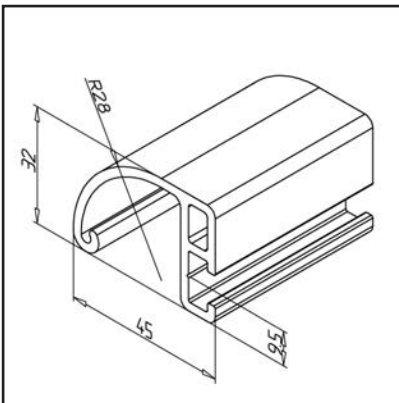

TECHN. DATA / ITEMS SUPPLIED

- Aluminium, extruded, anodized E6/EV1
- $I_x = 3.531 \text{ cm}^4$
- $I_y = 7.654 \text{ cm}^4$
- $w_x = 1.985 \text{ cm}^3$
- $w_y = 2.856 \text{ cm}^3$
- Weight = 0.890 kg/m
- Bar length = 6 m

APPLICATIONS

- Handle of diverse lengths
- Sheet edges
- Work station end points
- Cover ledge for cable, pneumatic conducts

ASSEMBLY

- Screw connection
- Angles
- Lateral cover with end cap left **part no. 22.1055/0** and right **part no. 22.1054/0**

HANDLE PROFILE 32

Part no.

20.1088/0

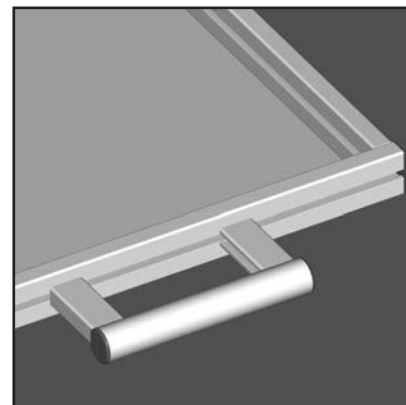
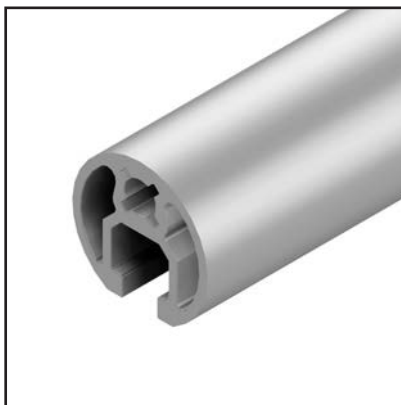
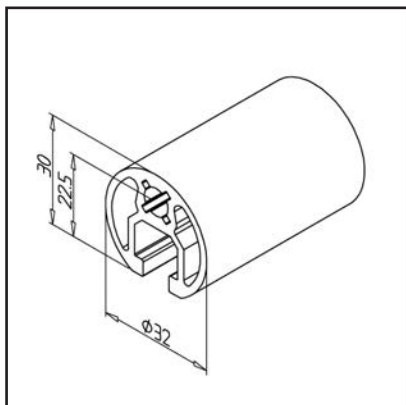
**TECHN. DATA / ITEMS SUPPLIED**

- Aluminium, extruded, anodized E6/EV1
- $I_x = 2.601 \text{ cm}^4$
- $I_y = 2.636 \text{ cm}^4$
- $w_x = 1.682 \text{ cm}^3$
- $w_y = 1.649 \text{ cm}^3$
- Weight = 0.911 kg/m
- Bar length = 6 m
- Packing unit = 84 m

APPLICATIONS

- Handles of different lengths for doors, drawers, handrails
- Edging of surface elements or posters up to 8 mm
- Profile section for suspending roller tracks or similar

ASSEMBLY

- Angle 19 GD-Z, **part no. 21.2078/0**
- Bolt connector
- Screw connection
- Lateral cover with end cap for handle profile 32

ANGULAR PROFILE 89 X 89

Part no.

20.1011/0

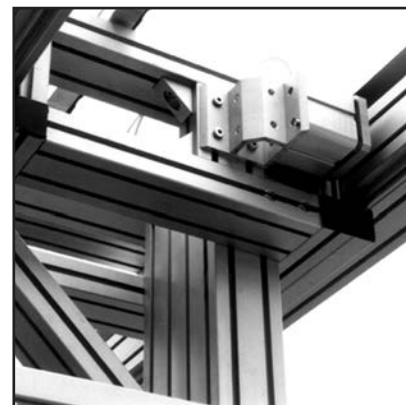
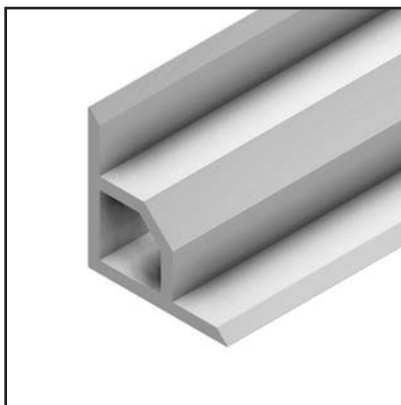
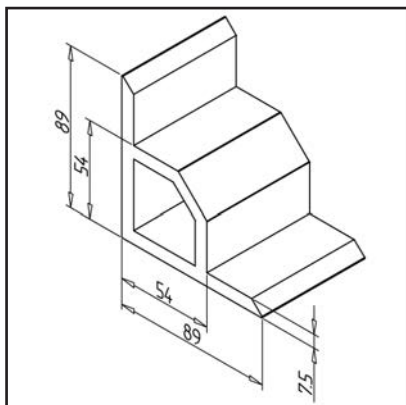
**TECHN. DATA / ITEMS SUPPLIED**

- Aluminium, extruded, anodized E6/EV1
- $I_x = 105.416 \text{ cm}^4$
- $I_y = 105.416 \text{ cm}^4$
- $w_x = 17.413 \text{ cm}^3$
- $w_y = 17.413 \text{ cm}^3$
- Weight = 4.868 kg/m
- Bar length = 3 m
- Packing unit = 12 m

APPLICATIONS

- Consoles
- Contact areas
- Starting material for the production of custom mounting brackets

ASSEMBLY

- Screws M8 x 20 and square nuts M8

PROFILE CAPS

SELF-LOCKING PROFILE CAPS FOR ALUMINIUM PROFILES

Due to unprotected profile ends, dirt and foreign bodies can penetrate into the inside of the profiles, which can lead to hygienic problems not only in sensitive environments. All this is prevented by profile caps: The profiles remain clean and protected, the risk of cutting injuries is minimized. Last but not least, they harmoniously round off the look of the aluminium profiles. In practice, however, it is annoying for users when these functions are no longer guaranteed due to loose and falling out profile caps.

This problem is effectively solved with our self-locking profile

caps. These are permanently anchored in the profile by means of an integrated safety pin. It therefore remains at the intended location even under extreme conditions and under the toughest conditions. True to the motto "The Art of Simplicity", the Minitec profile caps are very easy to use: The locking pin is hammered flush into the profile using a plastic hammer. Nevertheless, the profile cap can be removed effortlessly: The pins are punched through with a pin four millimeters in diameter. Separately available spare pins make the profile caps reusable.



Insert cap



Hammer the pin



Profile stays clean and protected

MINITEC ALUMINIUM PROFILE CAPS FOR HEAVY LOADS



Thread M08 shape



Tighten the cap
(Flat headed screw M08x10)



PROFILE CAPS

Profile sections	ABS grey	Al anodized (fastening screw included)	VA
------------------	----------	---	----

Profile series 30 (Thickness 3 mm)			
23x16	22.0994/1 *		
16x30	22.0981/1 *		
23x23	22.0992/1 *		
23x30	22.0993/1 *		
30x30	22.1146/1 *	22.1149/2	
30R90°	22.1144/1 *		
30R60°	22.1169/1 *		
30R45°	22.1168/1 *		
30R30°	22.1167/1 *		
30x60	22.1134/1 *		
60x60x30	22.0978/1 *		

Profile series 45 (Thickness 3 mm)			
19x32	22.1220/1 *	22.1060/2	
19x45	22.1001/1 *	22.1064/2	
45x19	22.1136/1 *		
32x32	22.1002/1 *	22.1062/2	
45x32	22.1003/1 *	22.1065/2	
45x32 clamp profile	22.1046/1	22.1065/2	
45x45	22.1004/1 *	22.1067/2	22.1067/5
45R4	22.1137/1 *		
45R90°	22.0996/1 *	22.0996/2	
45R60°	22.1018/1 *	22.1018/2	
45R45°	22.1017/1 *	22.1017/2	
45R30°	22.1019/1 *	22.1019/2	
Profile height adjustment	22.0979/1		
45/45°	22.0995/1 *		
45/22,5°	22.1052/1		
19x90	22.1014/1		
90x32	22.0982/1		
45x90	22.1007/1 *	22.1068/2	
45x60	22.1058/1		
60x60	22.1057/1		
45x135	22.1049/1		
45x180	22.1048/1		
90x90	22.0983/1 *	22.1008/2	
90R90°	22.1021/1		
32x180	22.1059/1		
90x180	2x 22.0983/1*	2x 22.1008/2	
270x19	3x 22.1014/1		
HANDLE PROFILE	right 22.1054/0 left 22.1055/0		
HANDLE PROFILE 32	22.1162/1 *		

* With pin

ACCESSORIES	material	Part No.
Flat head screw M8x10 for fixing caps made of aluminum or stainless steel	VA	21.1666/0
Replacement pins for caps with hammer taps (10 pack)	ABS grey	22.1009/1

Other covers	material	Part No.
End cap G for G-Profile 45	PA6 grey	22.1056/0
End cap GL for G-Profile 45	PA6 grey	22.1208/1
End cap G for G-Profile 30	PA6 grey	22.1182/1
End cap GL for G-Profile 30	PA6 grey	22.1183/1
Lamella plug 7	PE grey	22.1200/1
Plug 7	PE grey	22.1215/1
Lamella plug 9	PE grey	22.1201/1
Lamella plug 15	PE grey	22.1202/1
Lamella plug 22	PE grey	22.1209/1

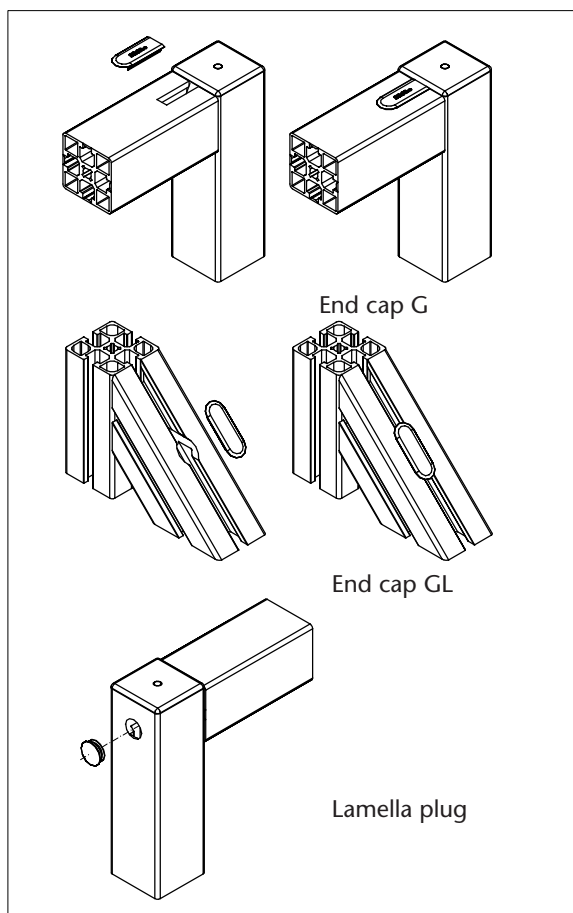

SEALING	material	Part No.
Seal plate 45	Silicon	24.1117/0
Seal plate 45 with slot	Silicon	24.1116/0
Seal plate 45 with double-slot	Silicon	24.1118/0

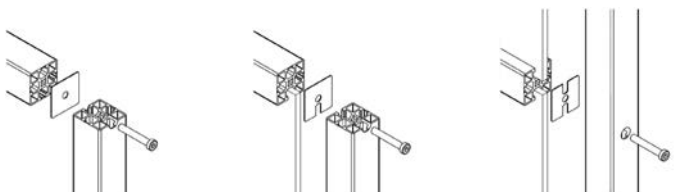

- Seal plate 45

- Seal plate 45 with slot

- Seal plate 45 with double-slot

POWER-LOCK FASTENER

PROFILE CONNECTION WITHOUT MACHINING



Due to recent studies there is much optimization potential especially in connection technology for profile systems. The connection must be seen as a complete system.

The total cost of a connection is composed of a number of factors:

- Design and dimensioning of bores and threads
- Providing equipment and devices
- Procurement and management of drilling and threading tools
- Work Preparation
- Working time for drilling, threading
- Internal transport

The decisive factor in this consideration is not the cost of the individual connectors. Fundamental cost factor is working time - both in design, production planning and workshop.

MiniTec power-lock fastener 45 SF

Apart from the cost and time advantages, the MiniTec power-lock fastener has numerous other advantages such as subsequent adjustment, ESD suitability, ergonomic design and optical advantages. The MiniTec power-lock fastener has become even faster with the thread-forming screws. The connector is simply screwed to the profile with the screw at the front. With a standard cordless screwdriver this whole process takes a maximum of 3 seconds. No preparation for drilling, threading, measuring or planning is required. Not only the economic superiority speaks for the MiniTec connector with self-tapping screw: Thanks to the trilobular shank shape combined with the radius profile shape of the thread flanks, the new screws develop low torques. The radius profile shape causes low material displacement and reduces the amount of forming work required. The torque moments are up to 50% lower. This ensures reliable assembly and higher clamping forces with less clamping force dispersion.

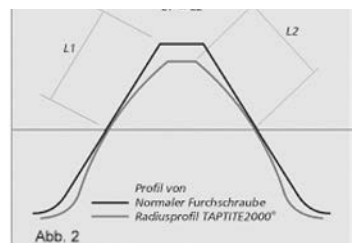
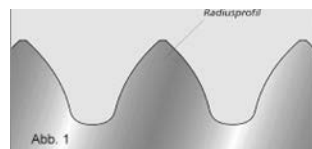

POWER-LOCK FASTENER

PROFILE CONNECTION WITHOUT MACHINING

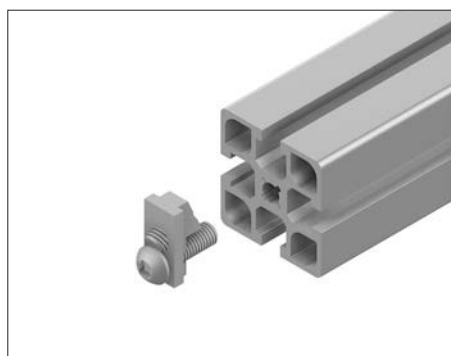

1

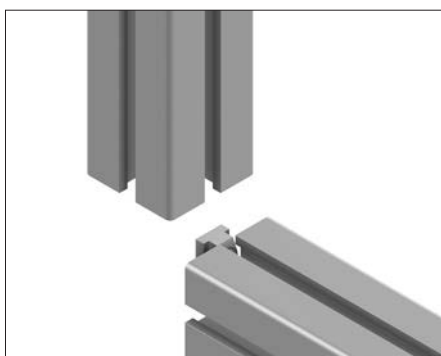

2



3

ASSEMBLY

1. Slightly tighten pressure piece with screw M8 x 25 on the front side of the profile
2. Push profile 2 with its groove beneath the edges of the pressure piece until the desired position is reached
3. Tighten the screw M8 with hex screwdriver SW4. Recommended tightening torque approximately 12 Nm

Advantages

- The corners of the profile connection remain free for surface elements
- The joint is invisible from the outside
- Secured against rotation
- Load capacity: 6000 N (UL-Profile: 4000N)
- Cross connections can be easily implemented
- For ESD applications, the electrical conductivity of the two profiles must be produced separately for this connector. *
- Ergonomically optimized
- With the "SF" version, no thread needs to be inserted in the profile beforehand. The thread is produced automatically by screwing the screw into the central bore of the profile.

Name	Part no.	Description
Power-Lock fastener 45	21.1018/0	with filister screw M8/SW5
Power-Lock fastener 45 SF	21.0818/0	with self-tapping Torx screw M8/T40,
Power-Lock fastener 45 H	21.1018/1	Cylindrical screw M8/SW5, Corrosion resistant version for use in corrosive environments
Power-Lock fastener 45 SF short *	21.0020/0	with self-tapping Torx screw M8/T40, for profile connections with flush end cap
Power-Lock fastener30	21.0014/0	with filister screw M8/SW5
Power-Lock fastener 30 SF	21.0016/0	with self-tapping Torx screw M8/T40



Impulse wrench **Part no. 26.0800/0**
for particularly joint-gentle work.

CROSS-CONNECTOR

FRICTIONAL CONNECTION OF INTERSECTING PROFILES WITHOUT MACHINING



Both profiles are adjustable in direction of the groove. Particularly suitable for the attachment of linear axes LR / LB to machine frames.

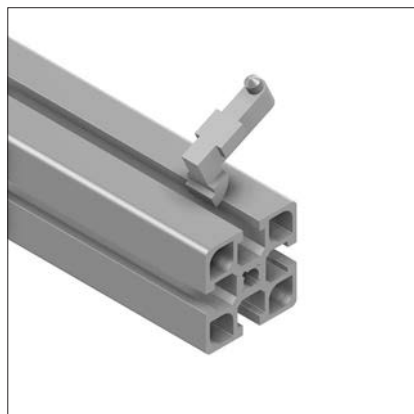

1

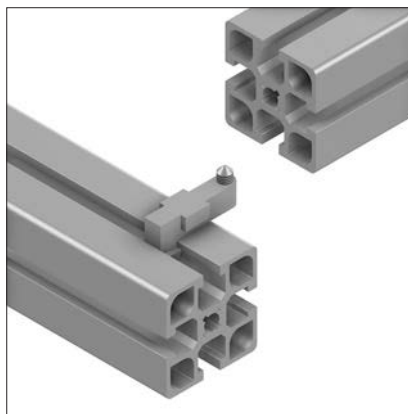

2

ASSEMBLY

1. Swivel the connector into any existing base frame
2. Insert the profile to be connected over the connector
3. Position the brace profile
4. Tighten the set screw in the connector with a torque of 10 Nm

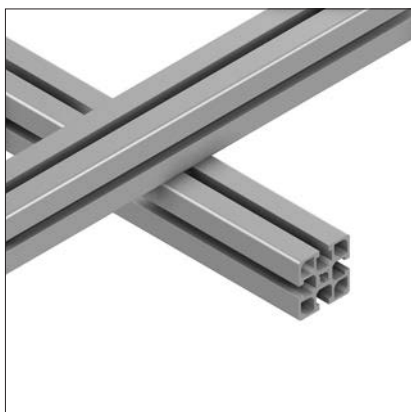

3

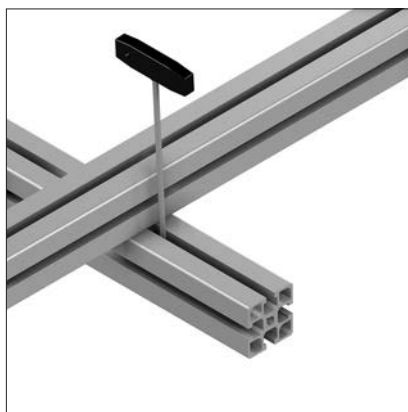

4

POWER-LOCK FASTENER N

FOR SUBSEQUENT FITTING OF PROFILES INTO EXISTING FRAMES WITHOUT MACHINING

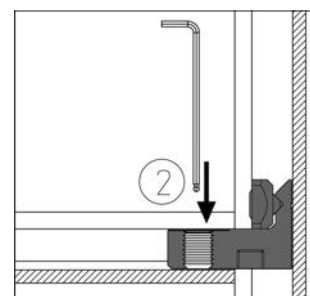
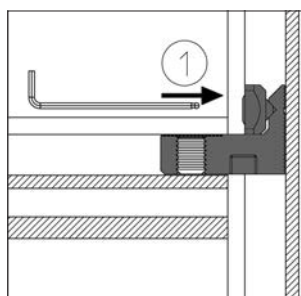
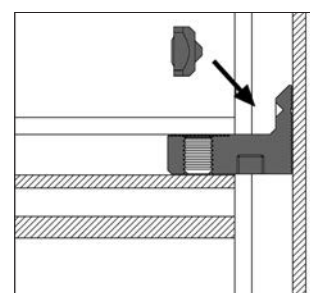
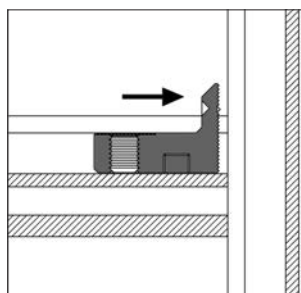
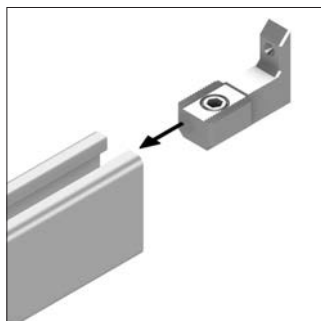
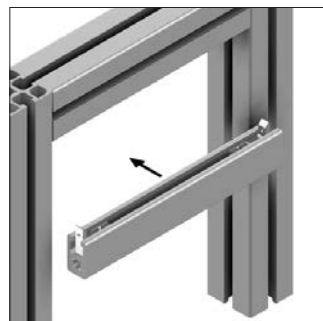
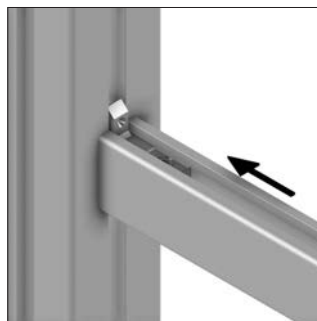
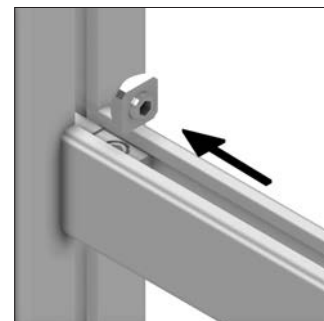
**1****2****3****4**

ASSEMBLY

1. Slide the connector into the strut to be retrofitted
2. Position the strut in the construction
3. Slide connector into existing profile
4. Insert square nut with pre-assembled stud into the groove, position via connector and tighten, then tighten screw in connector (both 10 Nm).

MITRE CONNECTIONS

CONSTRUCTIONS WITH HIGH VISUAL DEMANDS

Mitre connections are used for high visual requirements on design. It should be noted that the capacity of these compounds are less than standard connectors. For heavily loaded structures mitre connections should not be used!

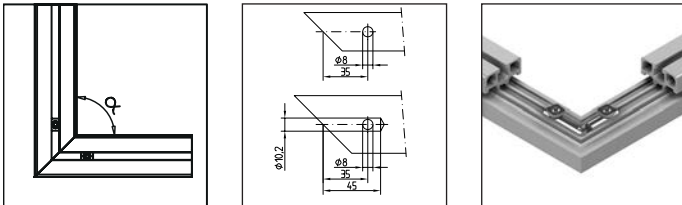

Mitre connector
for front side connection of profiles at any angle of 30° to 180°

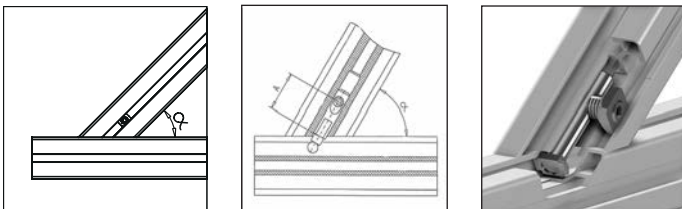

Mitre connector N
for connecting profiles with the grooves of continuous profiles at any angle of 30° to 90°

Description	Part no.	Description
Mitre connector 45 for profiles series 45	21.1400/0	Drill Ø 10.2 mm bore in the profile core bore. Drill Ø 8.2 bore at the distance 36.5 mm from the profile end. Insert the mitre connector in both open profile ends, position the M8 square nut with the set screw and tighten it.
Mitre connector 30 for profile series 30	21.1890/0	Core bore needs no machining. Other installation steps like mitre connector 45.
Mitre connector N 45 for profile series 45	21.1401/0	Drill Ø 10.2 mm bore in the profile core bore. Drill Ø 8.2 bore depending on the angle and at distance A from the profile end /see table). Insert the mitre connector in the open profile end, position the M8 square nut with the set screw and tighten it.
Mitre connector N 30 for profiles series 30	21.0945/0	Core bore needs no machining. Other installation steps like mitre connector N 45.

TIPP ✓

- Drilling jig part no. 26.1050/0 for mitre connector 45
- Drilling jig part no. 26.1060/0 for mitre connector N45
- Drilling jig part no. 26.1063/0 for mitre connector 30
- Drilling jig part no. 26.1056/0 for mitre connector N30

MITRE CONNECTIONS

CONSTRUCTIONS WITH HIGH VISUAL DEMANDS

Drilling jig for mitre connector N30 / N45

Distance A (position of the lateral bore of the threaded pin) depends on the mitre angle. The exact amount is to be taken from the middle bore core drilling of the mitred profile to the middle of the drilling. To safely exclude dimensional errors and ensure the correct functioning of the connection, we recommend the use of our drilling jig for mitre connector N30, part no. 26.1056/0 or N45 part no. 26.1060/0.

Distances for common angles:

α	30°	35°	40°	45°	50°	55°	60°	65°	70°	75°	80°	85°	90°
A(mm)	21,0	22,9	24,8	25,9	27,0	27,6	28,2	28,6	29,0	29,2	29,4	29,45	29,5



Mitre connection N

Drilling jig for mitre connector 30 / 45

Distance A (position of the lateral bore of the threaded pin) for front-side connection of profiles is consistently 35 mm. The exact amount is to be taken from the middle bore core drilling of the mitred profile to the middle of the drilling. To safely exclude dimensional errors and ensure the correct junctioning of the connection, we recommend the use of our drilling jig for mitre connector 30, part no. 26.1063/0 or 45 part no. 26.1050/0.



Use of MiniTec drilling jigs

Slide jig central bore of the mitred profile to the stopper. Tighten with screw. Insert into profile with bore through the drilling guide inside the fixing screw.

BOLT AND BUTT CONNECTORS

SUBSEQUENT ASSEMBLY OF PROFILES INTO EXISTING FRAMES, EXTENSION OF PROFILES

Bolt connectors

To compensate for the lower load capacity compared to our standard connectors, bolt connectors should always be used in pairs. The weakening of the profile cross-section must be taken into account.

The correct functioning of this connection requires precise machining of the connecting bore. The distance from the end of the profile of 22.5 mm \pm 0.3 mm must be observed. Another criterion is the precise shape of the connecting bore. Deviations from the circular shape lead to a reduction in the load-bearing surface of the connector. It is therefore necessary to drill the connecting bore on a milling machine.

This connection is not suitable for constructions with air flow in the profile for pneumatic applications.

Butt connectors

The machining of the profiles corresponds to the machining of the connectors. For the profile extension we recommend the combination of steel butt connectors and clamping strips.

T-slot bar 90

- Profile extension
- Slide into profile groove and clamp with set screws
- No machining required
- For larger profile cross-sections or higher loads, please use several t-slot bars.
- Can be used in combination with butt connectors

Application

For rectangular connection of profiles

- Subsequent mounting of profiles into existing frames
- Adjustable
- Extension of profiles

Processing

Step drilling $\varnothing 7 / \varnothing 20$ mm, resp. $\varnothing 9 / \varnothing 15$ mm, 16 mm depth: middle of the groove, 20 mm from profile end. Use drilling jig for positioning.

1. Insert hex screw M8 x 35 in bolt and - if possible - pre-assemble square nut into second profil.
 2. Insert bolt in step drilling and connect with square nut.
 3. Pretighten with ball-headed key SW5. Final tightening with L-key 5 A/F.
- Recommended locking torque: 15 Nm
 - Static load: 3500 N

Mounting bracket 45

- Profile extension
- Connection of profiles
- Subsequent insertion of profiles into existing constructions
- Removable attachments
- Movable in groove direction

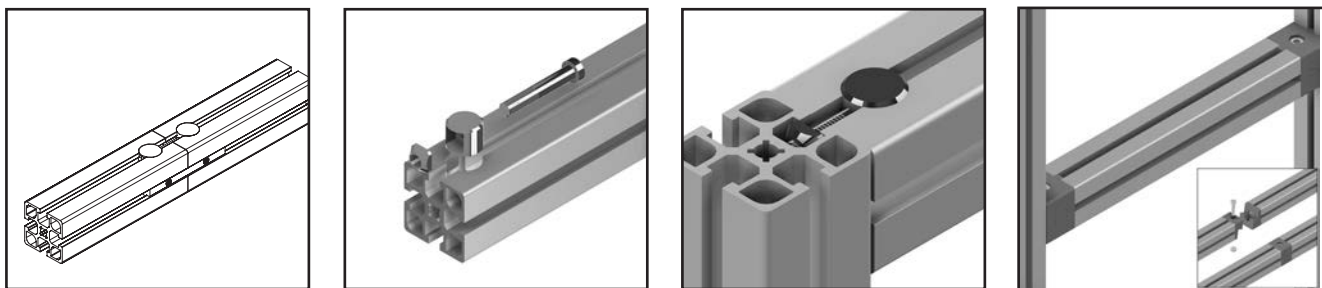

Description	Part no.	Description
Bolt connector 15	21.1024/0	For profile series 32 and narrow side 19 9x15 stepped bore, 16 mm tief, 22,5 mm from the end of profile
Bolt connector 20	21.1021/0	For profile series 45 7x20 stepped bore, 16 mm deep, 22,5 mm from the end of profile
Butt connector 20	21.1020/0	For profile series 45 7x20 stepped bore, 16 mm deep, 22,5 mm from both ends of profile
T-slot bar 90	21.1029/0	For profiles with grid dimension 45 Slide into groove and fasten
Mounting bracket 45	21.1411/0	For profiles with grid dimension 45 Insert face front thread



Drilling jig part no. **26.1092/0** for correct position of the stepped bore

SCREW CONNECTION

FORM-LOCKING CONNECTION WHICH MUST BE SECURED AGAINST DISLOCATION



APPLICATION

- Construction with high dynamic loads

Processing

Thread M8; step drilling $\varnothing 9 / \varnothing 15$ mm with drilling jig M8 x 50;

- Position anti-twist lock in the groove
- Push the screw through anti-twist lock
- Screw in and tighten the screw into threaded connection profile
- Recommended locking torque: 20 Nm
- Static load: 18 000 N

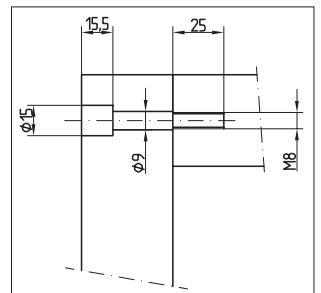
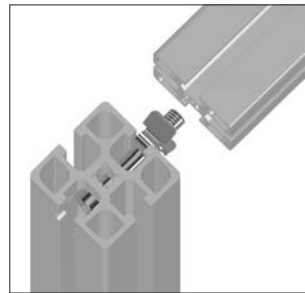
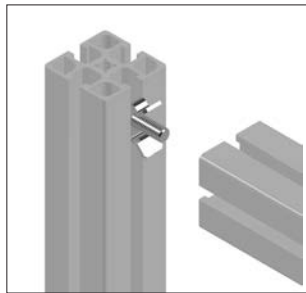
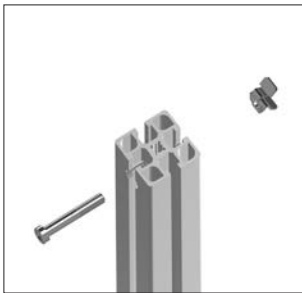

Stepped bore



Drilling jig part no. **26.1092/0** for correct position of the stepped bore

MOUNTING ANGLES

EASY INSTALLATION WITHOUT PROCESSING

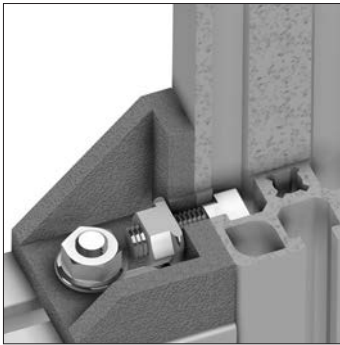

Angle aluminum die casting, powder coated, grey

- No processing
- Retrofitting of profiles possible
- Adjustable



Optional with cover

Caps made of oil resistant ABS, grey

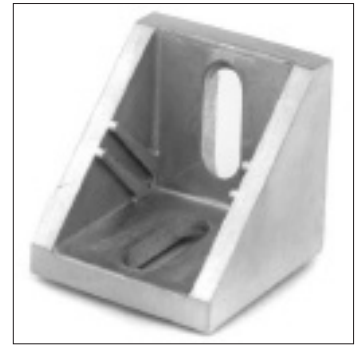

ESD version

- Without powder coating
- With ESD square nuts Z

ASSEMBLY

- Use fastening material from fastening kit.

LOAD CAPACITY

angle	Number of screws	Fmax (N)	Mmax (Nm)
Mounting angles 19	2	3.600	280
Mounting angle 25	2	3.600	280
Mounting angles 45	2	3.600	280
Mounting angles 45x90	4	7.200	560
Mounting angles 90	8	14.400	1.120

All values include double safety

These values are valid only for angles mounted in pairs if used one-sided, the load reduces as follows:

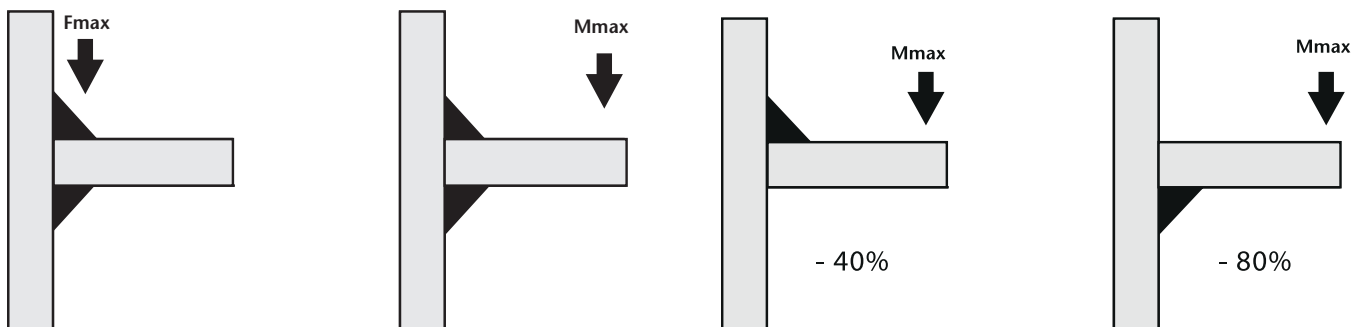

PROTECTIVE FIELD SUSPENSION, ADJUSTABLE ANGLE (part no. 21.1403/0)

CONNECTING PROTECTION FIELDS

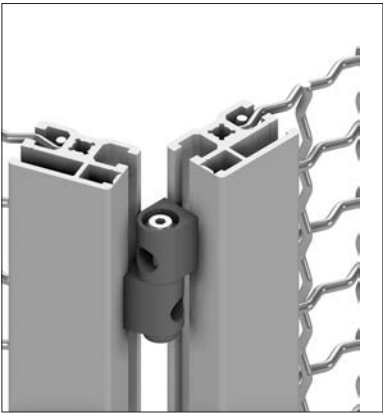

MOUNTING POSSIBILITIES

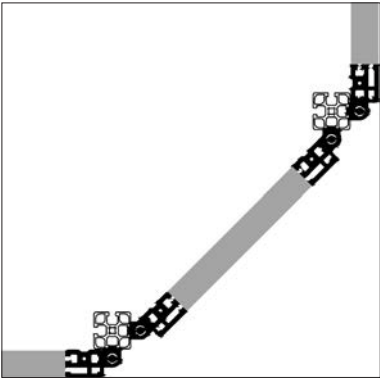
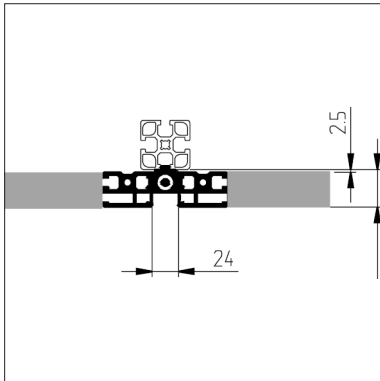
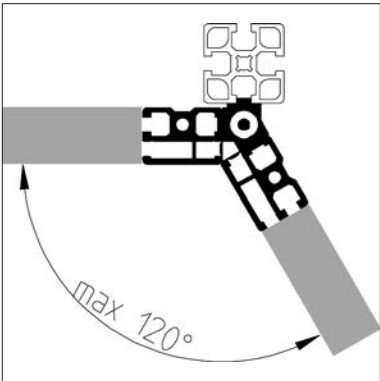
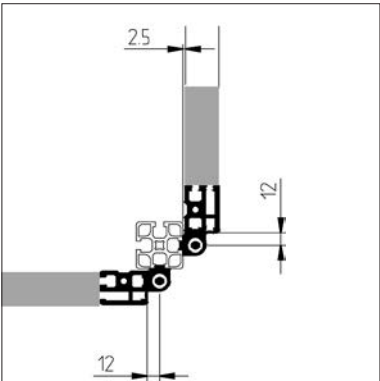

SCREWS

OTHER STANDARDS AND DIMENSIONS ARE AVAILABLE ON REQUEST

CYLINDER SCREWS

M8 with flat head and hexagon socket



Thread	Galvanized	Stainless
M08 x 12	21.1264/0	
M08 x 16	21.1200/0	21.1200/1
M08 x 18	21.1268/0	
M08 x 20	21.1202/0	21.1202/2
M08 x 22	21.1280/0	21.2017/0
M08 x 25	21.1204/0	21.1204/1
M08 x 30	21.1206/0	21.1206/1
M08 x 35	21.1208/0	21.1208/1
M08 x 40	21.1210/0	21.1210/1
M08 x 45	21.1211/0	
M08 x 50	21.1212/0	21.1212/1
M08 x 55	21.1877/0	
M08 x 60	21.1214/0	
M08 x 65	21.1299/0	
M08 x 70	21.1282/0	
M08 x 75	21.1392/0	
M08 x 80	21.1225/0	
M08 x 90	21.1226/0	
M08 x 100	21.1662/0	

M6 with flat head and hexagon socket

Thread	Galvanized	Stainless
M06 x 12	21.1143/0	21.1143/1
M06 x 14	21.1367/0	
M06 x 16	21.1238/0	21.1238/1
M06 x 18	21.1239/0	
M06 x 20	21.1240/0	21.1340/1
M06 x 22	21.1265/0	
M06 x 25	21.1242/0	21.1242/1
M06 x 30	21.1243/0	21.1243/1
M06 x 35	21.1245/0	21.1693/0
M06 x 40	21.1247/0	21.1247/1
M06 x 45	21.1172/0	
M06 x 50	21.1171/0	21.1171/1
M06 x 55	21.1248/0	21.1248/1
M06 x 60	21.1154/0	
M06 x 65	21.1868/0	
M06 x 70	21.1591/0	

M5 with flat head and hexagon socket

Thread	Galvanized	Stainless
M05 x 08	21.1193/0	
M05 x 10	21.1279/0	
M05 x 12	21.1220/0	21.1220/1
M05 x 16	21.1235/0	
M05 x 20	21.1222/0	
M05 x 25	21.1224/0	21.1224/1
M05 x 30	21.1237/0	21.1237/1
M05 x 35	21.2195/0	
M05 x 40	21.1284/0	21.1284/1
M05 x 45	21.1219/0	
M05 x 50	21.1691/0	
M05 x 55	21.1353/0	

COUNTERSUNK SCREWS

M8 with hexagon socket



Thread	Galvanized	Stainless
M08 x 10	21.1552/0	21.1550/0
M08 x 12	21.1263/0	
M08 x 16	21.1513/0	21.1513/1
M08 x 20	21.1514/0	21.1514/1
M08 x 25	21.1520/0	
M08 x 30	21.1516/0	
M08 x 35	21.1947/0	
M08 x 40	21.1547/0	
M08 x 45	21.1645/0	
M08 x 50	21.1517/0	21.1517/1
M08 x 55	21.1546/0	
M08 x 60	21.1523/0	
M08 x 65	21.1949/0	
M08 x 70	21.1950/0	
M08 x 90	21.1946/0	

M6 with hexagon socket

Thread	Galvanized	Stainless
M06 x 10	21.2219/0	21.2219/1
M06 x 12	21.1518/0	
M06 x 16	21.1506/0	21.1506/1
M06 x 20	21.1507/0	
M06 x 25	21.1566/0	
M06 x 30	21.1508/0	
M06 x 35	21.1509/0	
M06 x 40	21.1510/0	
M06 x 45	21.1951/0	
M06 x 50		21.2236/1
M06 x 55	21.1511/0	
M06 x 60	21.1512/0	
M06 x 65	21.2156/0	
M06 x 70	21.2134/0	

M5 with hexagon socket

Thread	Galvanized	Stainless
M05 x 10	21.1532/0	
M05 x 12	21.1543/0	21.1595/0
M05 x 14	21.1519/0	
M05 x 16	21.1503/0	21.1503/1
M05 x 18	21.1537/0	
M05 x 20	21.1504/0	
M05 x 25	21.1505/0	
M05 x 30	21.1482/0	
M05 x 35	21.2215/0	
M05 x 40	21.2127/0	
M05 x 45	21.1945/0	21.1945/1
M05 x 50	21.2123/0	

M4 with hexagon socket

Thread	Galvanized	Stainless
M04 x 08	21.1500/0	
M04 x 10	21.1557/0	
M04 x 12	21.1948/0	
M04 x 16	21.1501/0	21.1501/1
M04 x 20	21.1502/0	
M04 x 25	21.1571/0	
M04 x 30	21.1203/0	

SQUARE NUTS, RHOMBUS NUTS AND SQUARE WASHERS

AVAILABLE FOR M3, M4, M5, M6 AND M8



Square nuts 30 with position-fixing, ESD-conductive

Description	Galvanized	Stainless
M8	21.1570/0	-
M6	21.1569/0	-
M5	21.1568/0	-
M4	21.1567/0	-

Square nuts



Description	Galvanized	Stainless
M8	21.1351/0	21.1351/1
M6	21.1330/0	21.1330/1
M5	21.1320/0	21.1320/1
M4	21.1310/0	21.1310/1
M3	21.1309/0	21.1309/1

Square nuts with position-fixing



Description	Galvanized	Stainless
M8	21.1351/2	21.1351/4
M6	21.1330/2	21.1330/4
M5	21.1320/2	21.1320/4
M4	21.1310/2	21.1310/4
M3	21.1309/2	21.1309/4

Square nuts Z, ESD conductive



Description	Galvanized	Stainless
M8	21.1390/0	-
M6	21.1391/0	-
M5	21.1627/0	-

Square nuts Z with position-fixing, ESD conductive



Description	Galvanized	Stainless
M8	21.1390/2	-
M6	21.1391/2	-
M5	21.1627/2	-

SPECIAL SCREWS

Screws for power-lock fastener



Fillister head screw	Galvanized	Stainless
M08 x 25	21.1189/0	-
M08 x 25 SF*	21.1492/0	-

*self-tapping thread

Screws for end caps VA/AL/LR



Flat head screw	Galvanized	Stainless
M08 x 10	-	21.1666/0

Square nuts can be pivoted at any point in the profile. When used in the vertical profile apply square nut with position-fixing. Can be pivoted like the standard square nut; the position-fixing holds the nut in the desired position.

Square nut Z must be used for ESD applications. Available from M5 to M8, with and without spring plate.

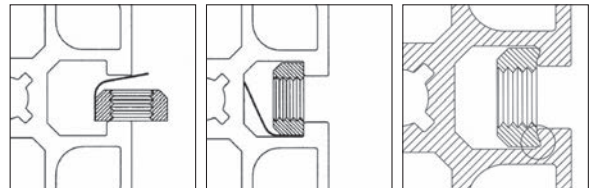

with position-fixing

ESD conductive

Square nuts M8 L



Description	Galvanized	Stainless
M8	21.1368/0	-

Square nuts M8 L with position-fixing



Description	Galvanized	Stainless
M8	21.1368/2	-

Rhombus nut F

(Thread M6 with pitch error for self-locking of the screw connection)



Description	Galvanized	Stainless
M6	21.1354/0	-

Square washers



Description	Galvanized	Stainless
Square washers 8	21.1360/0	21.1360/1
Square washers 6	21.1363/0	-
Square washers 5	21.1362/0	-

Hex nut with flange, self-locking



Description	Galvanized	Stainless
M8	21.1334/0	-

Screws for mounting surface elements



Flat head screw	Galvanized	Stainless
M06 x 12	21.2074/0	-
M06 x 16	21.1246/0	-
M06 x 20	21.1246/1	-

POWER-LOCK FASTENER 30 SF

Part no. 21.0016/0

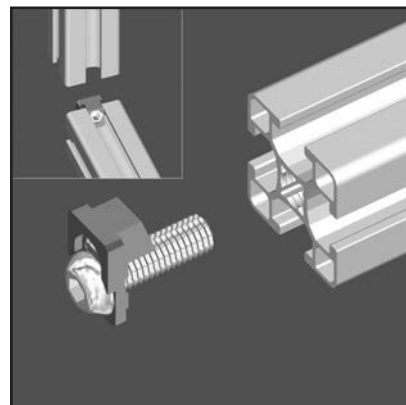
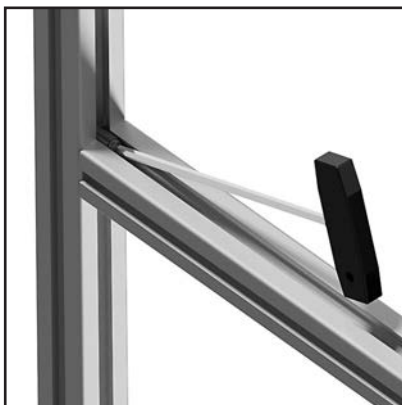
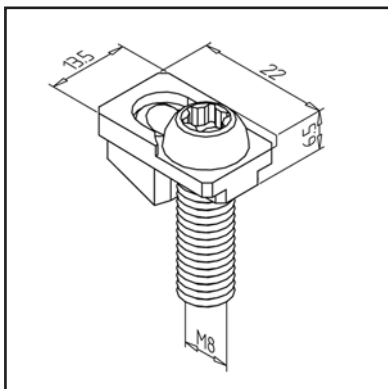

TECHN. DATA / ITEMS SUPPLIED

- Steel, galvanized
- Self tapping torx screw T40
- Power-Lock fastener 30 (standard) **part no. 21.1014/0** with filister head screw A/F 5
- Package size of 100 pieces in Kantainer version SF **part no. 21.0016/0100** version Standard **part no. 21.0014/0100**
- Weight = 0.021 kg/piece

APPLICATIONS

- For force-locked connection
- Also suitable for cross joints
- Appropriate for ESD implementations

ASSEMBLY

- Fasten the connector frontally to the profile with the torx wrench T 40
- Tighten the set screw M8 with the wrench SW 4
- Recommended locking torque: 12 Nm
- For screwing in self-tapping screws for MiniTec power-lock fastener: Impulse wrench **part No. 26.0800/0**

POWER-LOCK FASTENER 45 SF

Part no. 21.0818/0

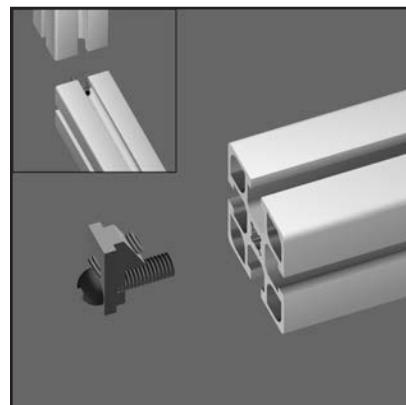
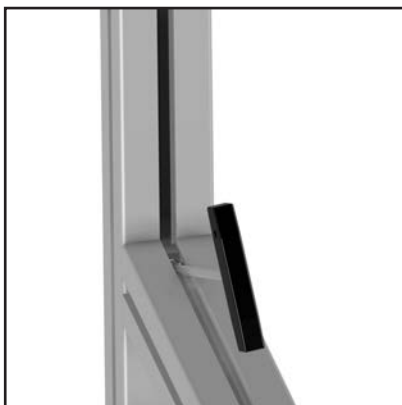
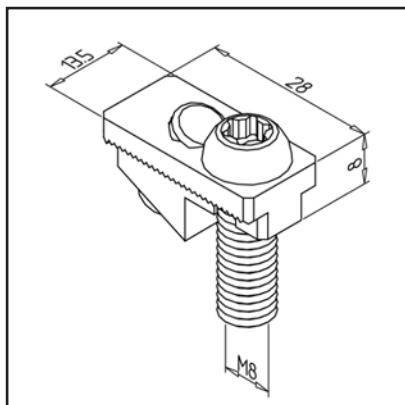

TECHN. DATA / ITEMS SUPPLIED

- Steel, galvanized
- Self tapping torx screw T40
- Power-lock fastener 45 (standard) **part no. 21.1018/0**, with filister head screw SW 5
- Power-Lock fastener 45 H - stainless version **part no. 21.1018/1** with cylinder head screw A/F 5
- Package size of 100 pieces in Kantainer version SF **part no. 21.0818/0100** version Standard **part no. 21.1018/0100**
- Weight = 0.030 kg/piece

APPLICATIONS

- Power-lock connection for all profiles, also suitable for crossjoints
- For larger profile sections several fasteners can be used
- Appropriate for ESD implementations

ASSEMBLY

- Fasten the connector frontally to the profile with the torx wrench T 40
- Tighten the set screw M8 with the wrench SW 4
- Recommended locking torque: 12 Nm
- For screwing in self-tapping screws for MiniTec power-lock fastener: Impulse wrench **part No. 26.0800/0**

POWER-LOCK FASTENER 45 SF SHORT

Part no.

21.0020/0

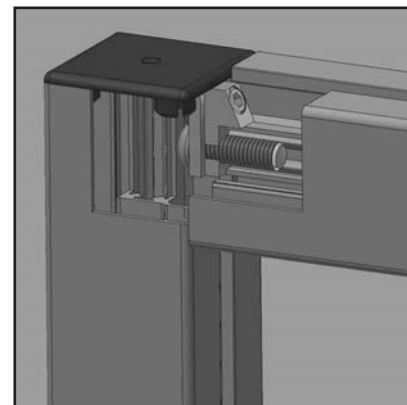
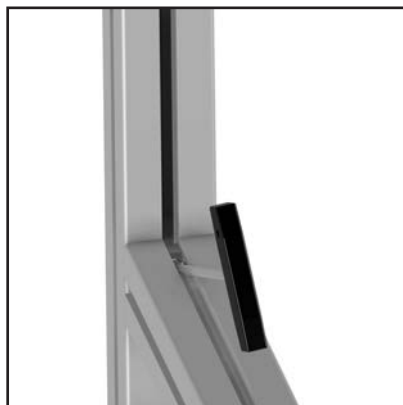
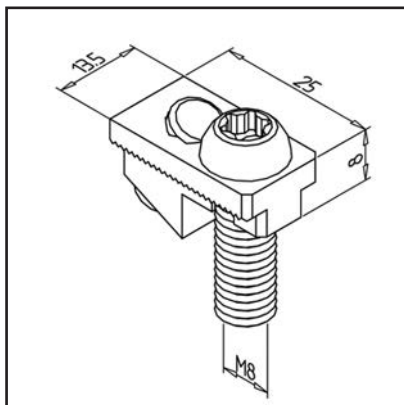
**TECHN. DATA / ITEMS SUPPLIED**

- Steel, galvanized
- Self tapping torx screw T40
- Weight = 0.028 kg/piece

APPLICATIONS

- For mounting profiles with flush cover cap
- For ESD applications of the fastener electr. conductivity of the two profiles has to be produced.

ASSEMBLY

- Fasten the connector frontally to the profile with the torx wrench T 40
- Tighten the set screw M8 with the wrench SW 4
- Recommended locking torque: 12 Nm
- For screwing in self-tapping screws for MiniTec power-lock fastener: Impulse wrench **part No. 26.0800/0**

POWER-LOCK FASTENER N 30

Part no.

21.0033/0

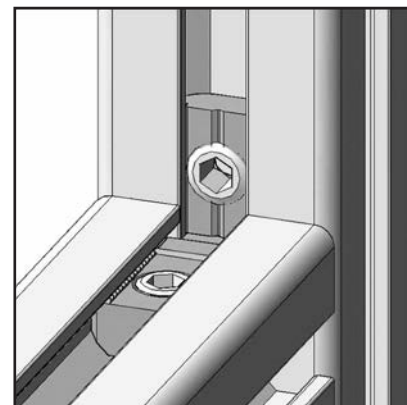
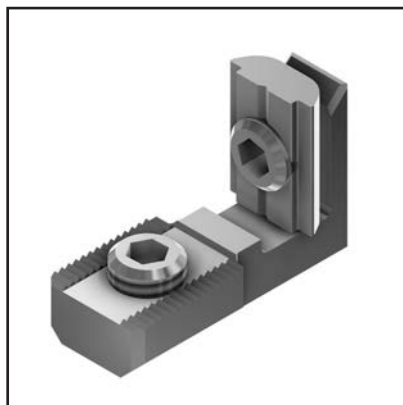
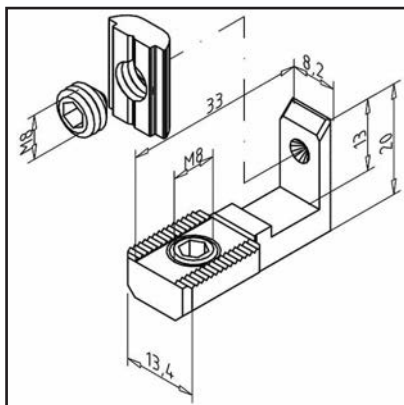
**TECHN. DATA / ITEMS SUPPLIED**

- Steel, galvanized
- Connection element with pre-assembled threaded pin M8
- 1 Slide nut M8 with pre-assembled setscrew
- Weight = 0.025 kg/piece

APPLICATIONS

- For force-locked connection
- Especially for post-mounting of additional profiles in existing constructions

ASSEMBLY

- Position the profile with the connector
- Swing in and tighten sliding nut with threaded pin
- Tighten set screw of fastener
- Tighten both threaded pins with SW 4 and with 10 Nm torque

POWER-LOCK FASTENER N 45

Part no.

21.0918/0

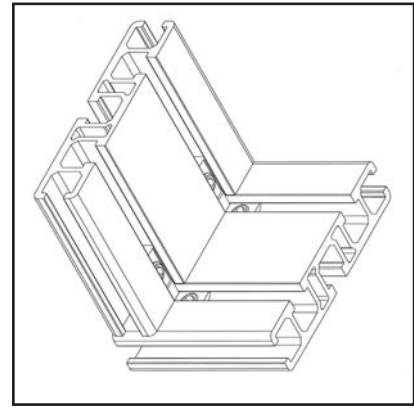
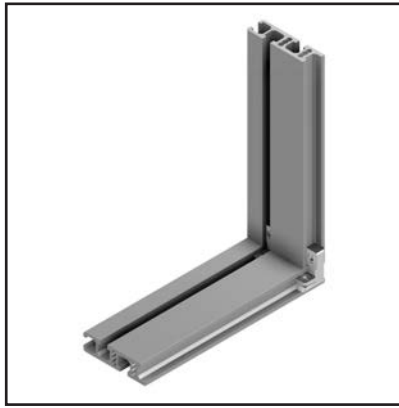
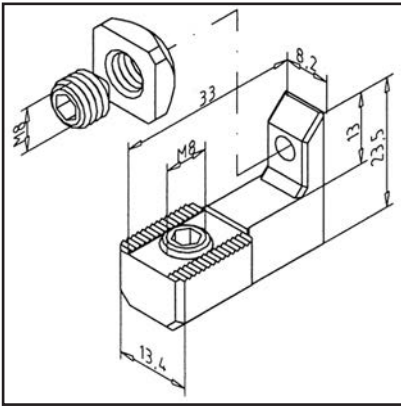

TECHN. DATA / ITEMS SUPPLIED

- Steel, galvanized
- Connection element with pre-assembled threaded pin M8
- 1 Slide nut M8 with pre-assembled setscrew
- Weight = 0.036 kg/piece

APPLICATIONS

- For connecting all profiles of the profile series 45
- Especially for post-mounting of additional profiles in existing constructions
- For profile sections bigger than 45 x 45 several fasteners can be used

ASSEMBLY

- Position the profile with the connector
- Swing in and tighten sliding nut with threaded pin
- Tighten set screw of fastener
- Tighten both threaded pins with SW 4 and with 10 Nm torque

CROSS-CONNECTOR 45

Part no.

21.0006/0

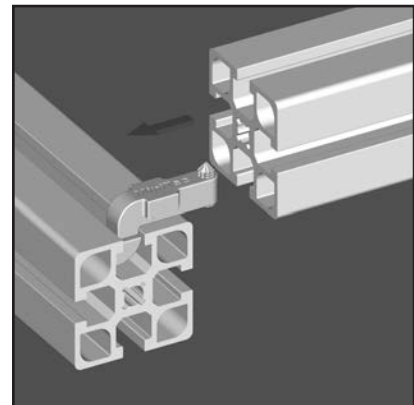
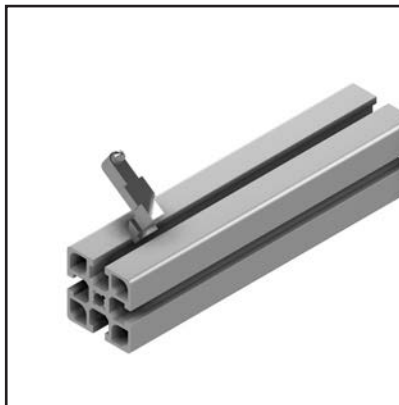
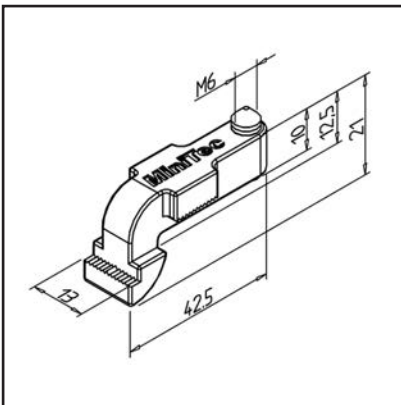

TECHN. DATA / ITEMS SUPPLIED

- Steel, galvanized
- Connection element with pre-assembled threaded pin M6
- Weight = 0.035 kg/piece

APPLICATIONS

- For connecting all profiles of the profile series 45
- Especially for retrofitting profiles into existing constructions
- Suitable for ESD applications

ASSEMBLY

- Swing the connector into the existing frame
- Push the new profile over the connector
- Tighten set screw in connector with wrench size 3 to 10 Nm torque

SCREW-CONNECTION 30 N

Part no.

21.1385/0

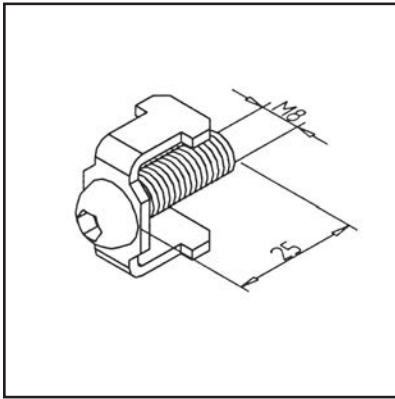

TECHN. DATA / ITEMS SUPPLIED

- Steel, galvanized
- Anti-twist lock with cylinder-head screw
- Weight = 0.017 kg/piece

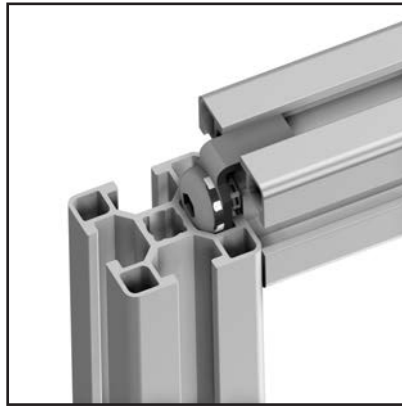

APPLICATIONS

- Connection of profiles

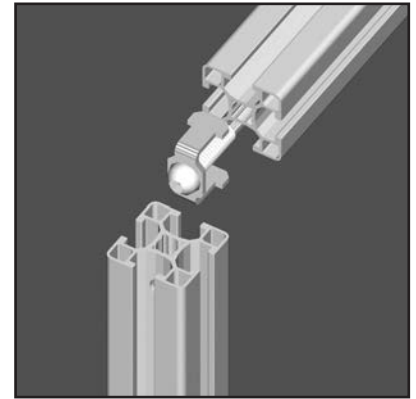

ASSEMBLY

- Bring in the Thread M8 x 25 in the centre borehole of the profile
- Insert bore \varnothing 7 mm in profile 2
- Install screw and anti-rotation lock on profile 1 and insert in groove of profile 2
- Pull through hole \varnothing 7 mm with Allen wrench
- Recommended locking torque: 20 Nm
- The bore \varnothing 7 mm can be closed with plug 7 **part no. 22.1215/1**, should be used with our closed t-slot profiles

SCREW CONNECTION 45

Part no.

21.1017/0

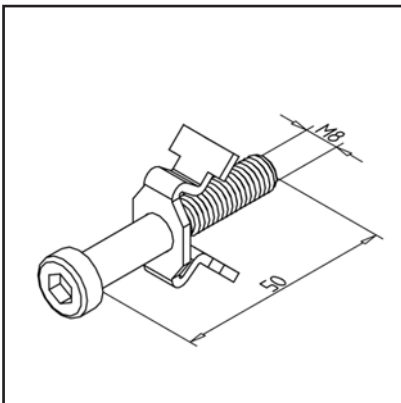

TECHN. DATA / ITEMS SUPPLIED

- Steel, galvanized
- Anti-twist lock with cylinder-head screw
- Weight = 0.027 kg/piece



APPLICATIONS

- Effective against slipping
- Secured connection of all profiles

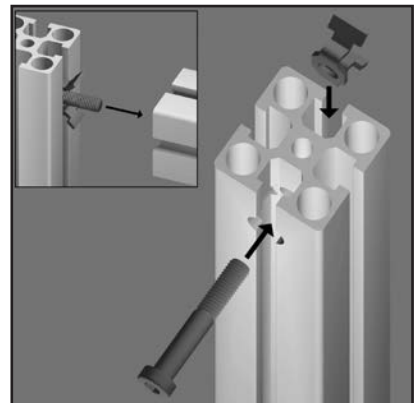

ASSEMBLY

- Insert the threaded screw M8 x 25 into the central bore of profile
- Insert the stepped bore \varnothing 9 x 15 into profile 2
- Insert the anti-twist lock
- Insert the screw through the anti-rotation lock into the tapped hole in profile 2, tighten
- Recommended locking torque: 20 Nm

SCREW CONNECTION 32

Part no. 21.1386/0

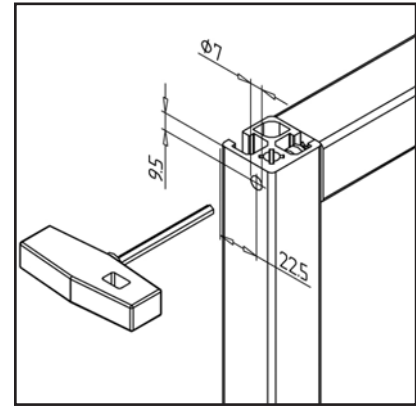
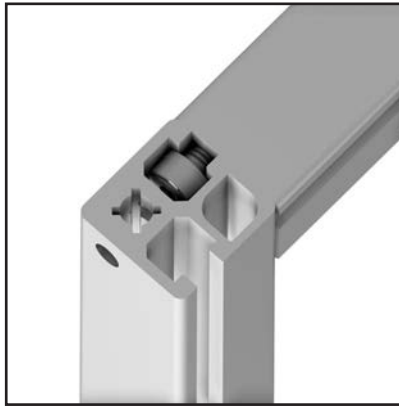
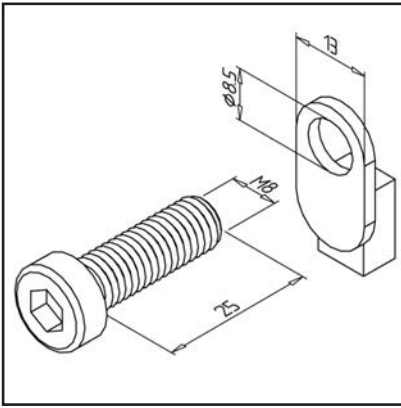

TECHN. DATA / ITEMS SUPPLIED

- Aluminium, Pressure die-casting
- Hex socket cap screw M8 x 25
- Weight = 0.015 kg/piece

APPLICATIONS

- Effective non-rotating connection for 32mm and 19mm profiles

ASSEMBLY

- Insert the threaded screw M8 x 25 into the central bore of profile
- Insert bore \varnothing 7 mm in profile 2
- Fasten the screw to the profile 1 with the anti-twist lock and insert it into profile 2
- Tighten the screw to 20 Nm
- The bore \varnothing 7 mm can be closed with plug 7 **part no. 22.1215/1**, should be used with our closed t-slot profiles

HAMMER SCREW

Part no. 21.1370/0

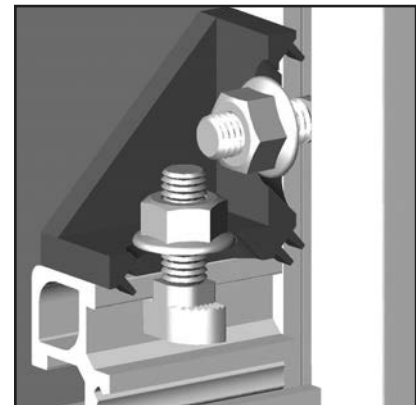
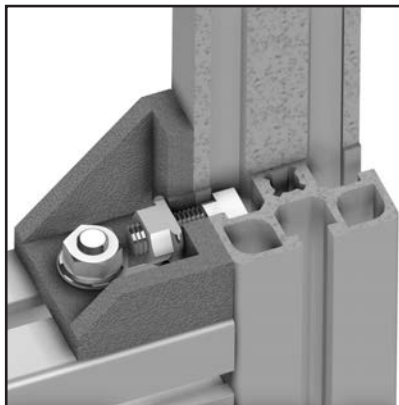
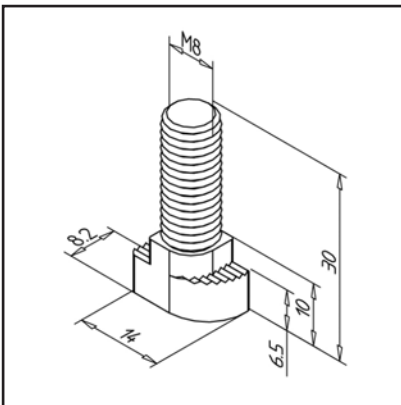

TECHN. DATA / ITEMS SUPPLIED

- Steel, galvanized
- Thread (d) : M 8
- Length (l) : 23.5 mm
- Weight = 0.013 kg/piece

APPLICATIONS

- Simple attachment of add-on parts or accessories on profiles
- Attachment of mounting bracket: 45 x 90 GD-Z **part no. 21.1397/0**, 45 GD **part no. 21.1133/0**, 45 GD-Z **part no. 21.1349/0**, 90 GD-Z **partno. 21.0978/0**

ASSEMBLY

- Insert the hammer screw in the profile groove, screw on nut M8
- When tightening the nut, the hammer head will turn crosswise
- **Recommended nut:** Hexagon nut self-locking with flange **part no. 21.1334/0**

BOLT CONNECTOR 15

Part no.

21.1024/0

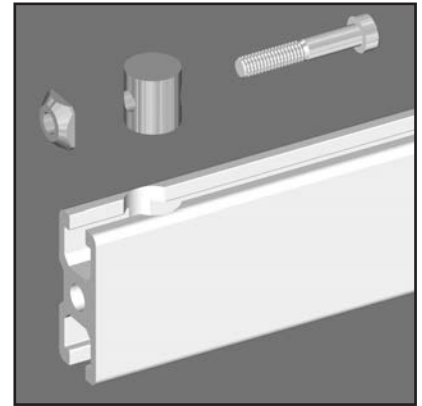
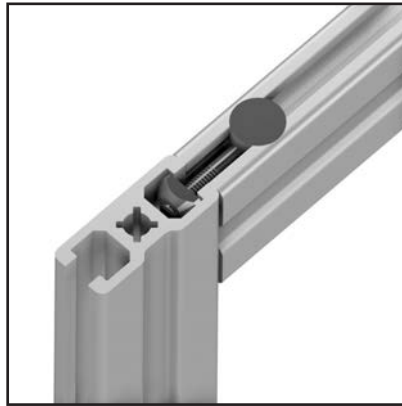
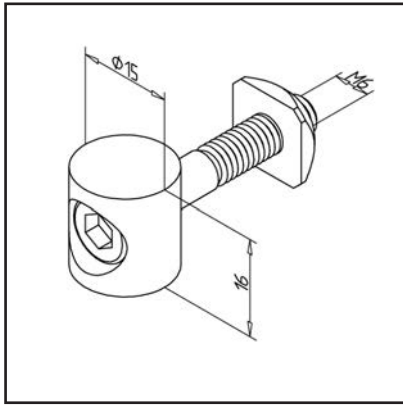
**TECHN. DATA / ITEMS SUPPLIED**

- Aluminium, anodized E6/EV1
- With fastening material steel, zinc plated
- Weight = 0.032 kg/piece

APPLICATIONS

- Connection of profiles 19 and 32
- Especially for post-mounting of additional profiles in existing constructions

ASSEMBLY

- Insert the stepped bore $\varnothing 9 \times 15$, 16 mm deep, positioned 22.5 mm from the end of the profile to the center of the groove
- Insert the connector and pre-tighten the screw with the ball head wrench SW 4
- Fastening with Allen wrench
- Recommended locking torque: 15 Nm

BOLT CONNECTOR 20

Part no.

21.1021/0

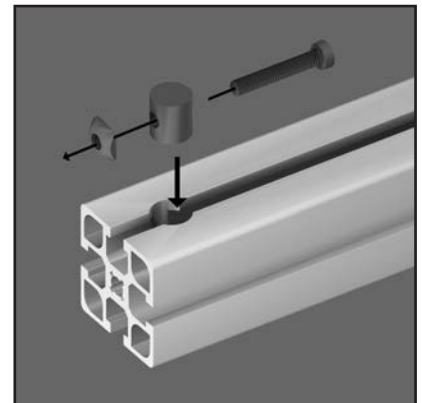
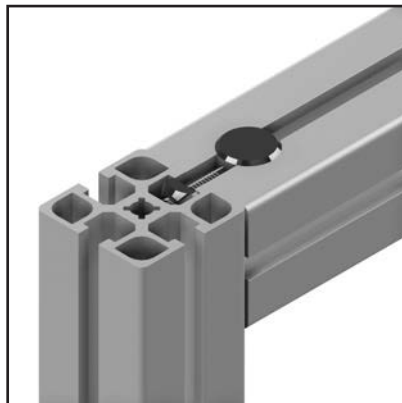
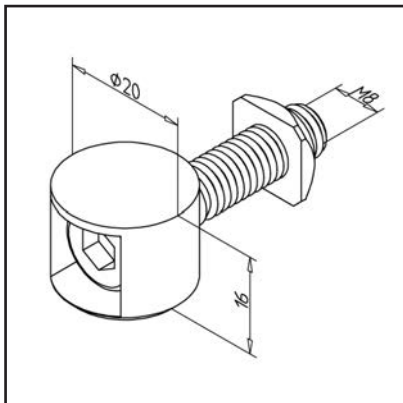
**TECHN. DATA / ITEMS SUPPLIED**

- Zinc, Pressure die-casting, galvanized
- With fastening material steel, zinc plated
- Weight = 0.036 kg/piece

APPLICATIONS

- For connecting all profiles of the profile series 45
- Especially for post-mounting of additional profiles in existing constructions
- For connection of profile 45 x 19

ASSEMBLY

- Insert the stepped bore $\varnothing 7 \times 20$, 16 mm deep, positioned 22.5 mm from the end of the profile to the center of the groove
- Insert the connector and pre-tighten the screw with the ball head wrench SW 5
- Fastening with Allen wrench
- Recommended locking torque: 15 Nm

BUTT CONNECTOR 20

Part no.

21.1020/0

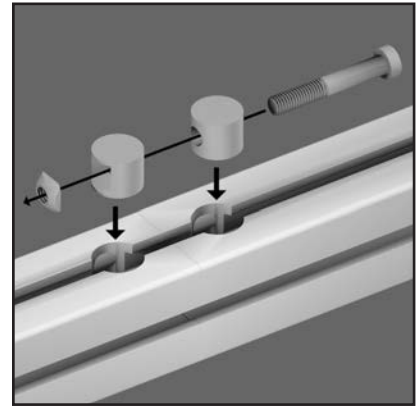
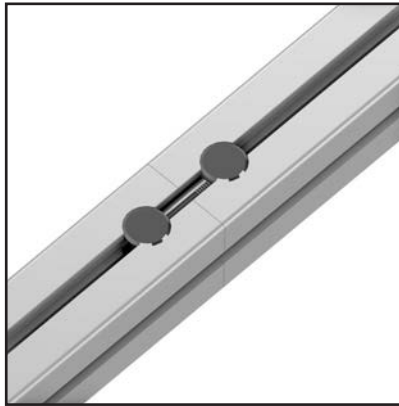
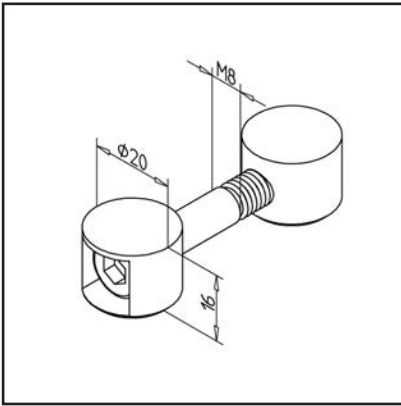

TECHN. DATA / ITEMS SUPPLIED

- Zinc, Pressure die-casting, galvanized
- With fastening material steel, zinc plated
- Weight = 0.056 kg/piece

APPLICATIONS

- Profile extension
- Butt connectors

ASSEMBLY

- Insert the stepped bore $\varnothing 7 \times 20$, 16 mm deep, positioned 22.5 mm from the end of the profile to the center of the groove
- Insert the connector and pre-tighten the screw with the ball head wrench SW 5
- Fastening with Allen wrench
- Recommended locking torque: 15 Nm

T-SLOT BAR 90

Part no.

21.1029/0

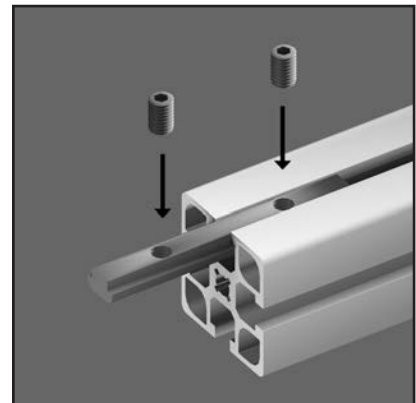
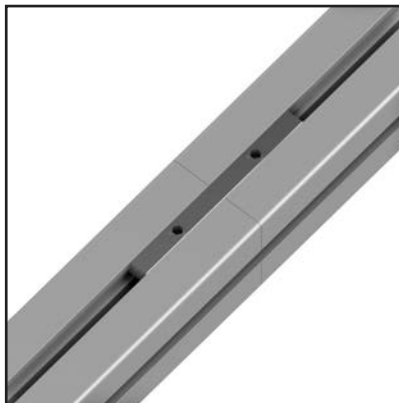
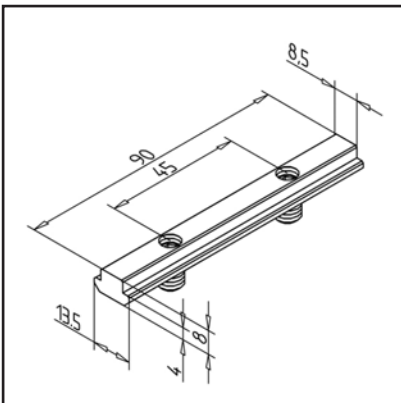

TECHN. DATA / ITEMS SUPPLIED

- Steel, galvanized
- 2 set screws M8, with hexagonal socket SW 4
- Stainless version **part no. 21.0992/0**
- Weight = 0.062 kg/piece

APPLICATIONS

- Profile extension
- Fastening rollers in standard carriages LW

ASSEMBLY

- Swing into profile groove
- Clamp with set screw
- No machining required
- For larger profile cross sections or higher loads, several clamping strips must be used

T-SLOT BAR 135

Part no.

21.0988/0

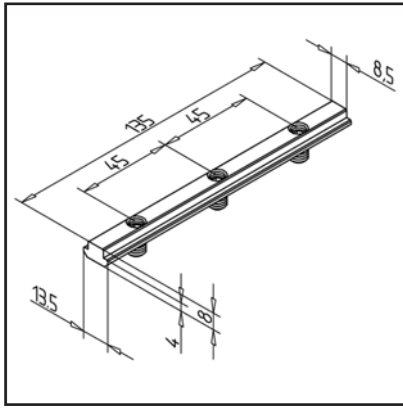
**TECHN. DATA / ITEMS SUPPLIED**

- Steel, galvanized
- 3 set screws M8, with hexagonal socket SW4
- Stainless version **part no. 21.0987/0**
- Weight = 0.094 kg/piece

**APPLICATIONS**

- Fastening rollers in standard carriages LW

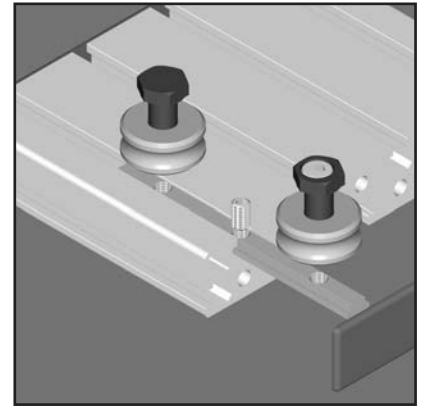
**ASSEMBLY**

- Swing into profile groove
- No machining required

T-SLOT BAR 140

Part no.

28.0026/0

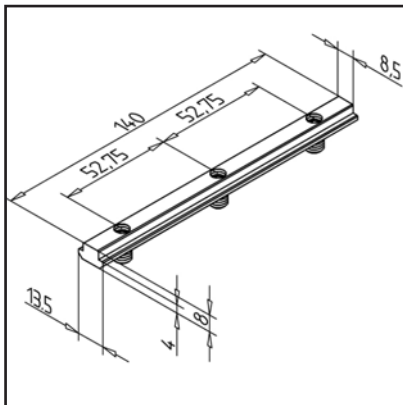
**TECHN. DATA / ITEMS SUPPLIED**

- Steel, galvanized
- 3 set screws M8, with hexagonal socket SW4
- Stainless version **part no. 28.0030/0**
- Weight = 0.096 kg/piece

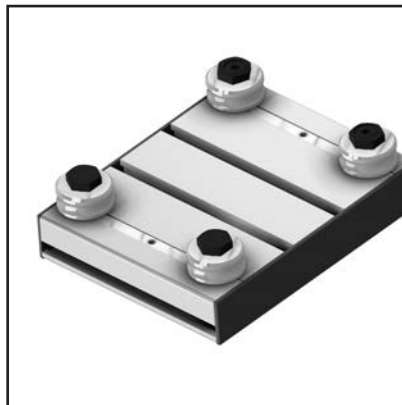
**APPLICATIONS**

- Fastening of pulleys in linear slide LW 32 E

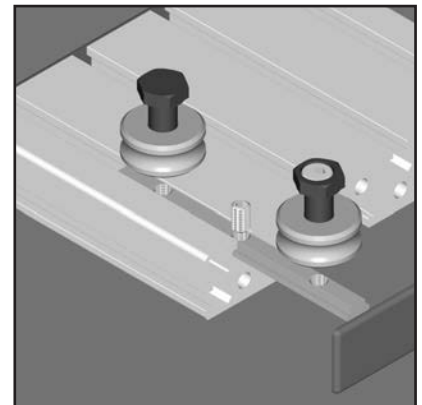
**ASSEMBLY**

- Swing into profile groove
- No machining required

T-SLOT BAR 180

Part no. 21.1101/0

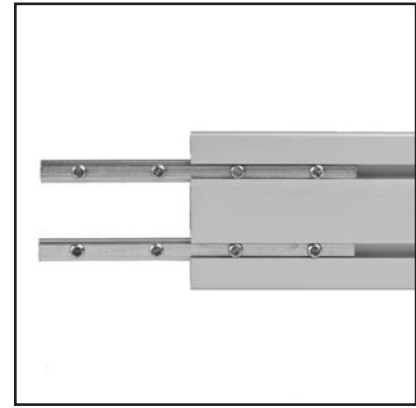
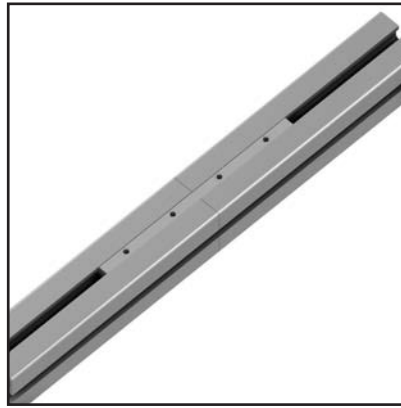
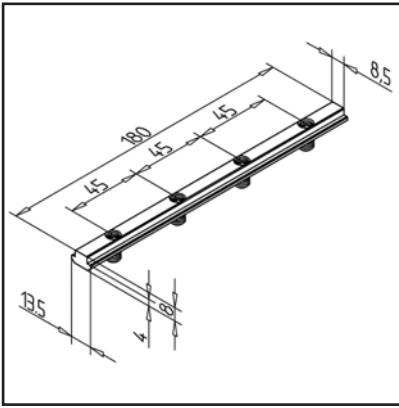

TECHN. DATA / ITEMS SUPPLIED

- Steel, galvanized
- 4 set screws M8, with hexagon socket SW4
- Stainless version **part no. 21.0986/0**
- Weight = 0.125 kg/piece

APPLICATIONS

- Front side connection at joining line
- Profile extension
- Fastening rollers in standard carriages LW

ASSEMBLY

- Swing into profile groove
- No machining required
- For larger profile cross sections or higher loads, several clamping strips must be used

T-SLOT BAR PROFILE

Part no. 21.1030/0

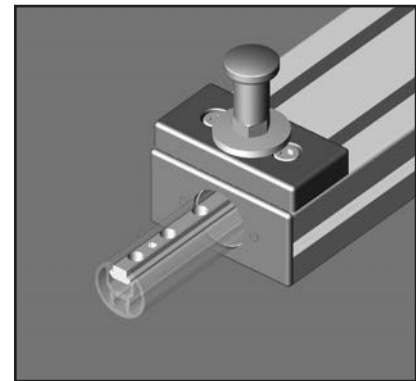
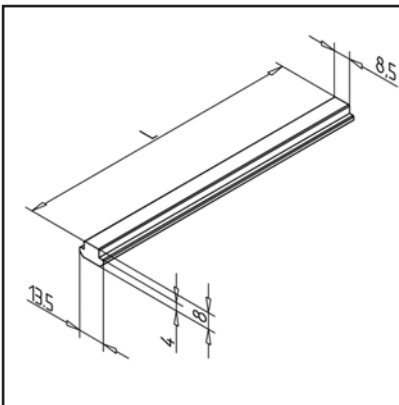

TECHN. DATA / ITEMS SUPPLIED

- Steel, bright
- Stainless version **part no. 21.1030/1**
- Weight = 0.650 kg/m
- Bar length = 3 m

APPLICATIONS

- Manufacture of terminal blocks, connecting elements in special lengths
- Production of reinforcements
- Ledges with special perforation

ASSEMBLY

- Swing into profile groove

MITRE CONNECTOR N 30

Part no.

21.0945/0

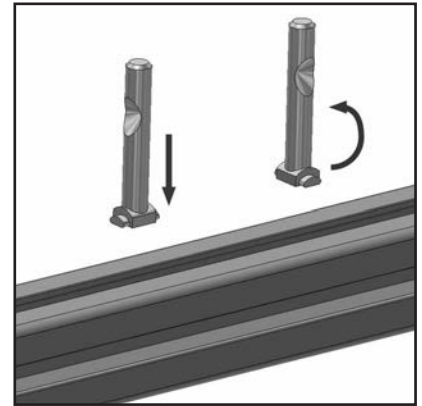
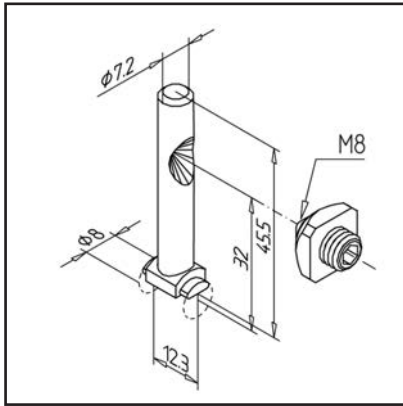
**TECHN. DATA / ITEMS SUPPLIED**

- Steel, galvanized
- With fastening material steel, zinc plated
- Weight = 0.023 kg/piece

APPLICATIONS

- Mitre connection of profiles on profile groove
- For subsequent fitting in the groove

ASSEMBLY

- Insert into groove and central bore
- Use a drilling jig for mitre connector N30
part no. 26.1056/0

MITRE CONNECTOR N 45

Part no.

21.1401/0

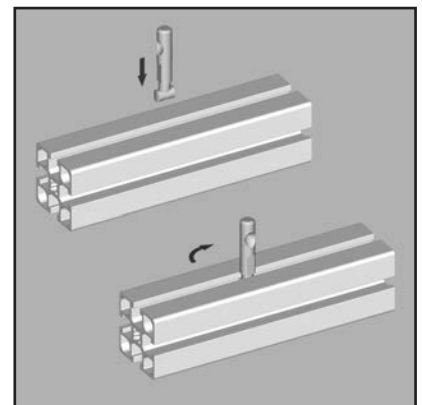
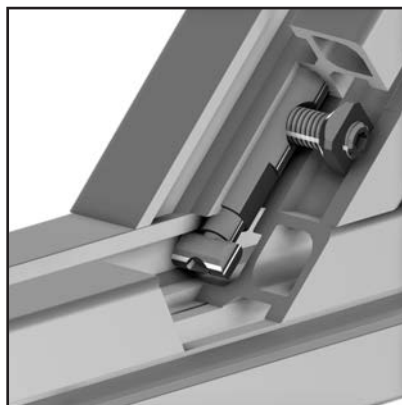
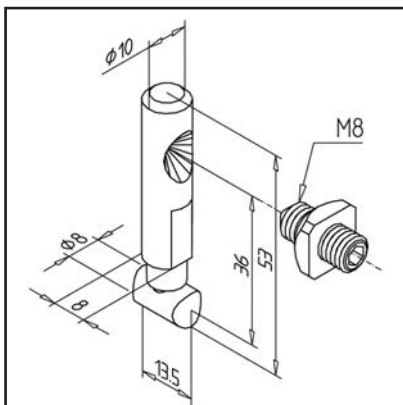
**TECHN. DATA / ITEMS SUPPLIED**

- Steel, galvanized
- With fastening material steel, zinc plated
- Weight = 0.035 kg/piece

APPLICATIONS

- Mitre connection of profiles on profile groove
- For subsequent fitting in the groove

ASSEMBLY

- Drill profile bore of $\phi 10.2$ mm
- Use a drilling jig for mitre-connector N45
part no. 26.1060/0

MITRE CONNECTOR 30

Part no.

21.1890/0

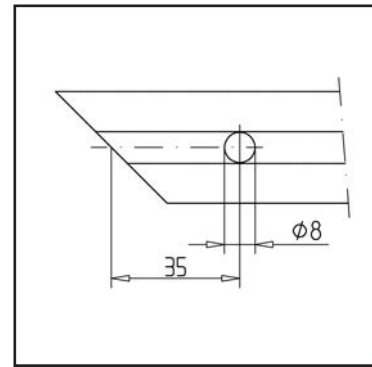
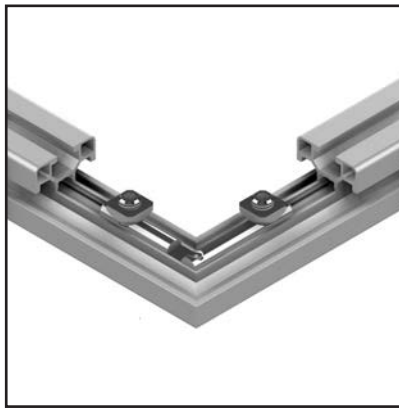
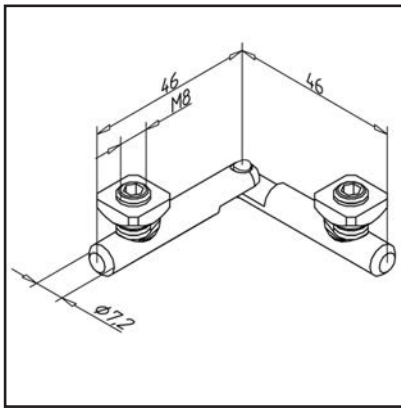

TECHN. DATA / ITEMS SUPPLIED

- Steel, galvanized
- With fastening material steel, zinc plated
- Weight = 0.040 kg/piece

APPLICATIONS

- display windows, showcases
- Store equipment
- Displays
- Frames

ASSEMBLY

- Insert the miter connector 30 into both profile ends
- Position the sliding nuts M8 above the bores and screw in the threaded pin. Attach the connector with the threaded pin M8
- Drilling jig **part no. 26.1063/0**

MITRE CONNECTOR 45

Part no.

21.1400/0

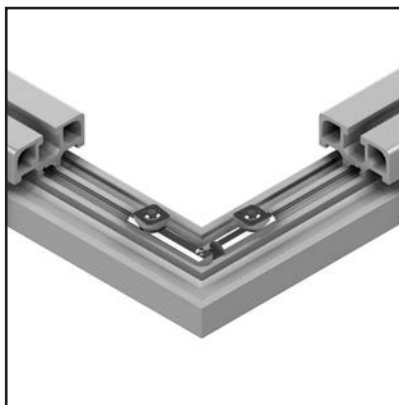
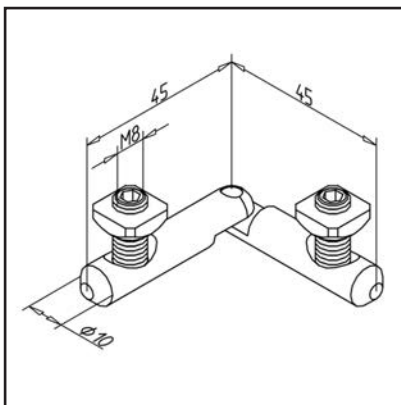

TECHN. DATA / ITEMS SUPPLIED

- Steel, galvanized
- With fastening material steel, zinc plated
- Weight = 0.065 kg/piece

APPLICATIONS

- display windows, showcases
- Store equipment
- Displays
- Frames

ASSEMBLY

- Insert the miter connector into both profile ends
- Position the sliding nuts M8 above the bores and screw in the threaded pin. Attach the connector with the threaded pin M8
- Use a drilling jig for mitre-connector 45 **part no. 26.1050/0**

MOUNTING BRACKET 30

Part no.

21.2068/0

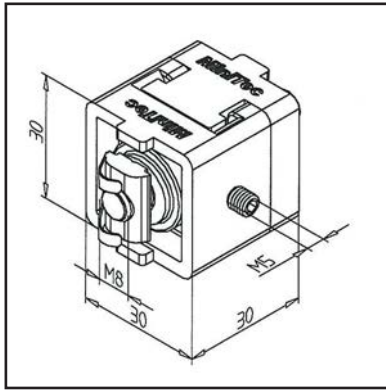
**TECHN. DATA / ITEMS SUPPLIED**

- PA, Injection Mould, grey
- With fastening material steel, zinc plated
- Weight = 0.041 kg/piece

**APPLICATIONS**

- Connection of profiles
- Profile extension
- Subsequent insertion of profiles into existing constructions, displaceable in groove direction
- Removable attachments

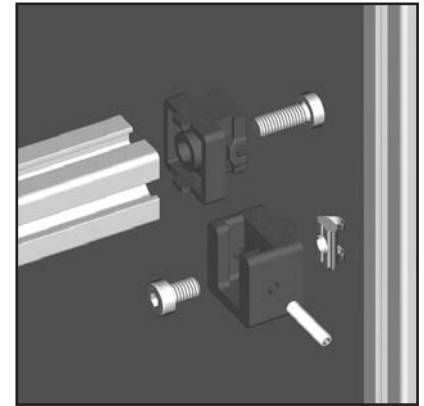
**ASSEMBLY**

- Fasten to profiles with supplied hardware
- Insert cross-tie profile into T-solt
- For adjustment use set screw M5

MOUNTING BRACKET 45

Part no.

21.1411/0

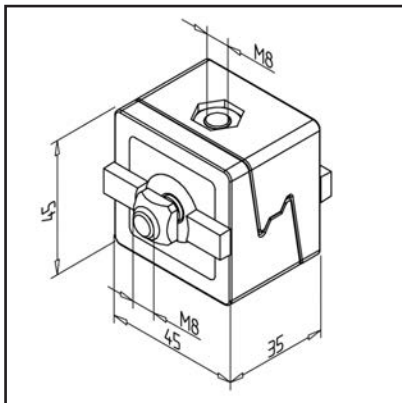
**TECHN. DATA / ITEMS SUPPLIED**

- Zinc, Pressure die-casting, powder-coated, grey
- With fastening material steel, zinc plated
- Weight = 0.429 kg/piece

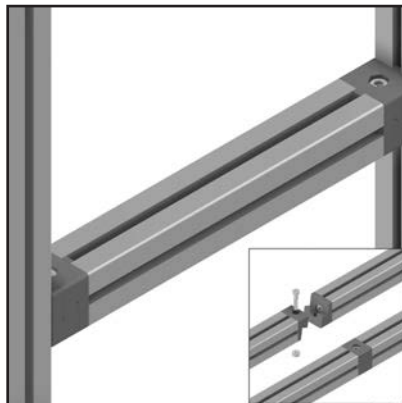
**APPLICATIONS**

- Connection of profiles
- Profile extension
- Subsequent insertion of profiles into existing constructions
- Attaching bearing surfaces
- Removable attachments
- Slidable in the groove direction

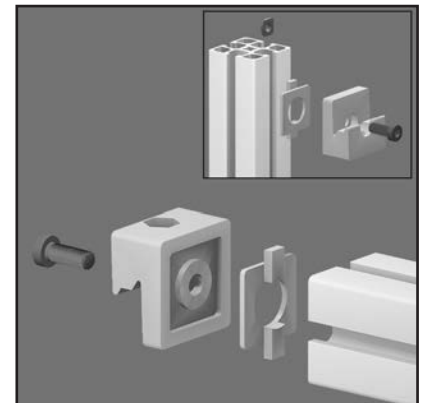
**ASSEMBLY**

- Fasten to profile groove with supplied hardware
- When retrofitting on a vertical groove, preferably use square nut M8 with nut fixation **part no. 21.1351/2**
- Recommended locking torque: 20 Nm

MOUNTING ANGLE 16 GD-Z

Part no.

21.2077/0

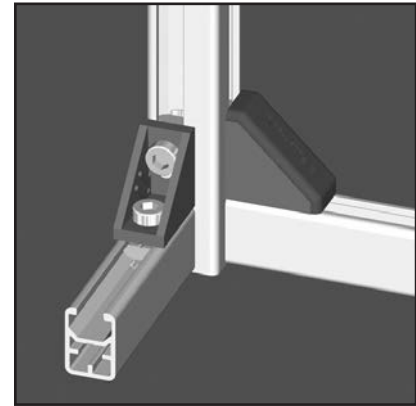
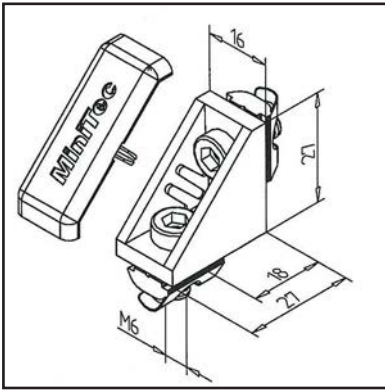

TECHN. DATA / ITEMS SUPPLIED

- Aluminium, Pressure die-casting, powder-coated, grey
- With fastening material steel, zinc plated
- Removable centering tabs
- **Conductive version part no. 21.2077/6**
- Weight = 0.021 kg/piece

APPLICATIONS

- Construction from profiles with width of 16 and 23; specifically suitable for the subsequent mounting of elements in existent constructions
- Fastening of surface elements, table tops
- Reinforcement of constructions made from profile series 16 or 23

ASSEMBLY

- Fasten to profile groove with supplied hardware
- Recommended torque: 8 Nm
- Fitting end cap MW 16 GD-Z grey, **part no. 22.1138/1**

MOUNTING ANGLE 19 GD-Z

Part no.

21.2078/0

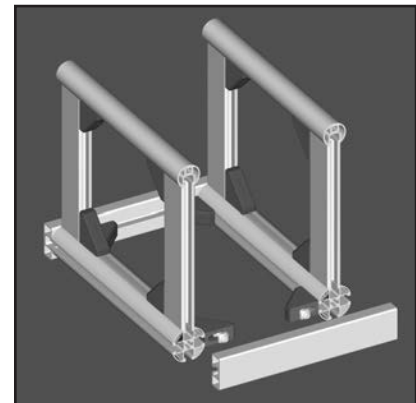
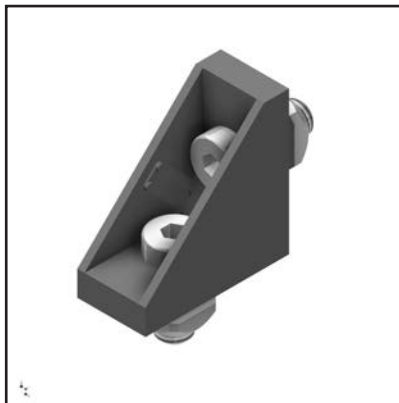
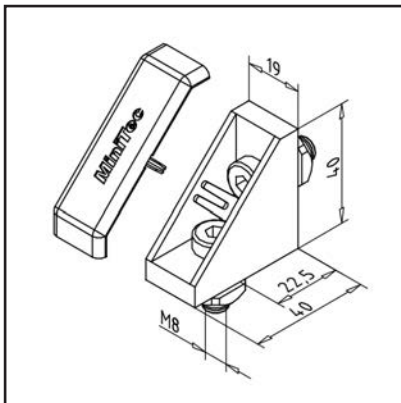

TECHN. DATA / ITEMS SUPPLIED

- Aluminium, Pressure die-casting, powder-coated, grey
- With fastening material steel, zinc plated
- Package size of 50 pieces **part no. 21.2078/050**
- **Conductive version part no. 21.2078/6**
- Use on vertical struts **part no. 21.2078/7** (square nut with position-fixing)
- Weight = 0.055 kg/piece

APPLICATIONS

- Connection of profiles 19 and 32
- Subsequent insertion of profiles into existing constructions
- Attaching bearing surfaces
- Slidable in the groove direction

ASSEMBLY

- Fasten to profile groove with supplied hardware
- Fitting end cap MW 19 GD-Z, grey, **part no. 22.1139/1**
- Recommended locking torque: 20 Nm

MOUNTING ANGLE 25 GD-Z

Part no.

21.0969/0

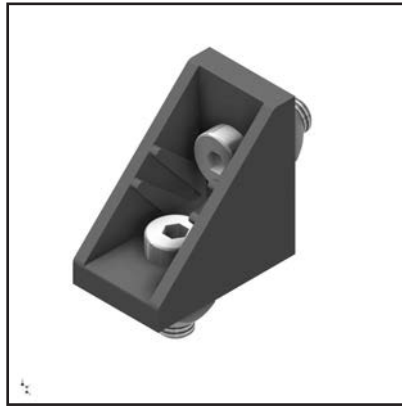
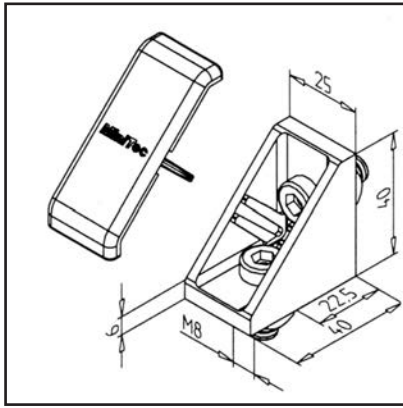
**TECHN. DATA / ITEMS SUPPLIED**

- Aluminium, Pressure die-casting, powder-coated, grey
- With fastening material steel, zinc plated
- Removable centering tabs
- Package size of 50 pieces **part no. 21.0969/050**
- **Conductive version part no. 21.0969/6**
- Use on vertical struts **part no. 21.0969/7** (square nut with position-fixing)
- Weight = 0.066 kg/piece

APPLICATIONS

- General constructions, particularly for subsequent insertion of profiles into existing constructions
- Fastening of surface elements, table tops
- Strengthening of profile constructions

ASSEMBLY

- Fasten to profile groove with supplied hardware
- If non-aligning grooves, break centering tabs with pliers
- Fitting end cap MW 25 GD-Z, **part no. 22.0997/1**
- Recommended locking torque: 20 Nm

MOUNTING ANGLE 25 S

Part no.

21.1134/0

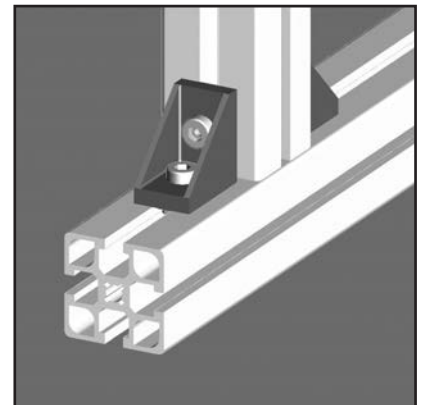
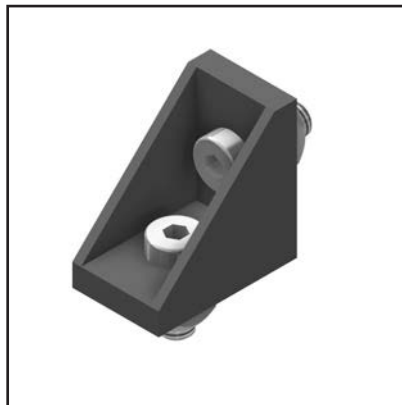
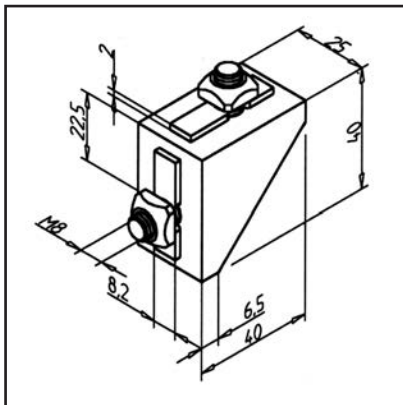
**TECHN. DATA / ITEMS SUPPLIED**

- Aluminium, Pressure die-casting, powder-coated, grey
- With fastening material steel, zinc plated
- With ridge as anti-twist device
- Package size of 50 pieces **part no. 21.1134/050**
- **Conductive version part no. 21.1134/6**
- Use on vertical struts **part no. 21.1134/7** (square nut with position-fixing)
- Weight = 0.067 kg/piece

APPLICATIONS

- General constructions, particularly for subsequent insertion of profiles into existing constructions
- Strengthening of profile constructions

ASSEMBLY

- Fasten to profile groove with supplied hardware
- Recommended locking torque: 20 Nm

MOUNTING ANGLE 30 GD

Part no.

21.0905/0

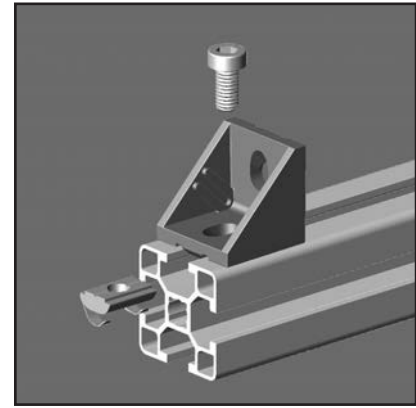
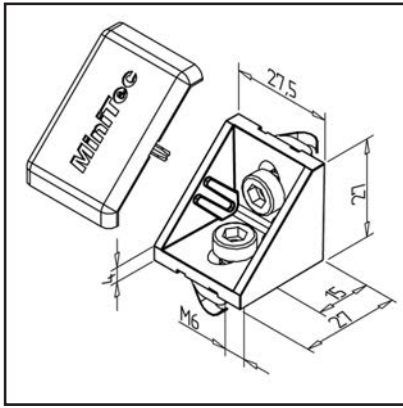

TECHN. DATA / ITEMS SUPPLIED

- Aluminium, Pressure die-casting, powder-coated, grey
- With fastening material steel, zinc plated
- Removable centering tabs
- Package size of 50 pieces **part no. 21.0905/050**
- conductive version **part no. 21.0905/6**
- Weight = 0.029 kg/piece

APPLICATIONS

- All types of constructions; specifically suited for the subsequent mounting of elements in existing constructions
- Fastening of surface elements, table tops

ASSEMBLY

- Strengthening of profile constructions
- Fasten to profile groove with supplied hardware
- Recommended torque: 8 Nm
- Fitting end cap MW 30 grey, **part no. 22.0989/1**

MOUNTING ANGLE 45 GD

Part no.

21.1133/0

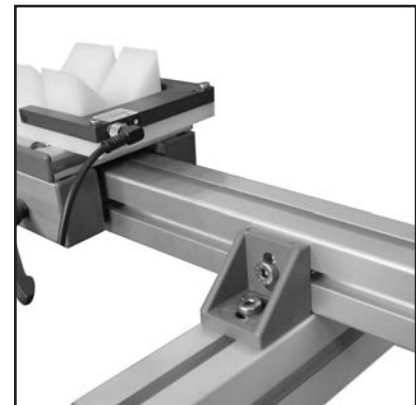
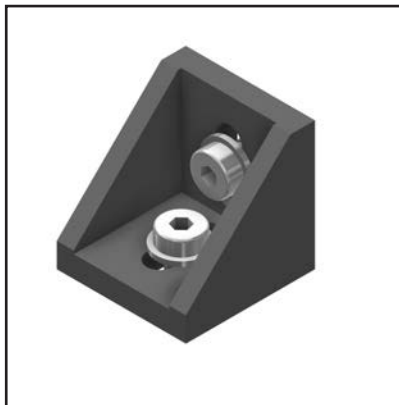
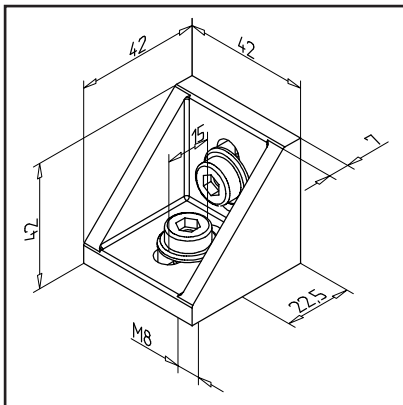

TECHN. DATA / ITEMS SUPPLIED

- Aluminium, Pressure die-casting, powder-coated, grey
- With fastening material steel, zinc plated
- Package size of 50 pieces **part no. 21.1133/050**
- **Conductive version part no. 21.1133/6**
- Use on vertical struts **part no. 21.1133/7** (square nut with position-fixing)
- Weight = 0.114 kg/piece

APPLICATIONS

- General constructions, particularly for subsequent insertion of profiles into existing constructions
- Fastening of surface elements, table tops
- Strengthening of profile constructions

ASSEMBLY

- Fasten to profile groove with supplied hardware
- Hammer head screw **part no. 21.1370/0** can be used
- Recommended locking torque: 20 Nm

MOUNTING ANGLE 45 GD-Z

Part no. 21.1349/0

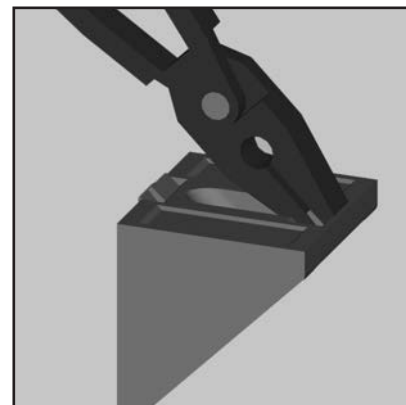
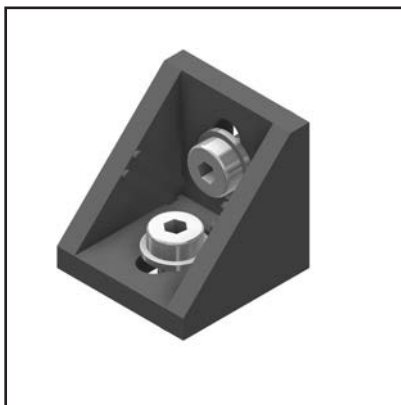
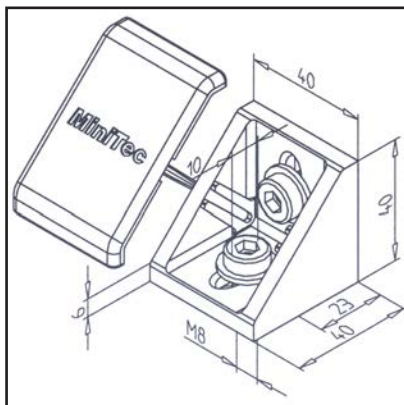
**TECHN. DATA / ITEMS SUPPLIED**

- Aluminium, Pressure die-casting, powder-coated, grey
- With fastening material steel, zinc plated
- Removable centering tabs
- Package size of 50 pieces **part no. 21.1339/050**
- Package size of 50 pieces **part no. 21.1349/750**
- Conductive version **part no. 21.1349/8**
- Use on vertical struts **part no. 21.1349/7** (square nut with position-fixing)
- Weight = 0.086 kg/piece

APPLICATIONS

- General constructions, particularly for subsequent insertion of profiles into existing constructions
- Fastening of surface elements, table tops
- Strengthening of profile constructions

ASSEMBLY

- Fasten to profile groove with supplied hardware
- If non-aligning grooves, break centering tabs with pliers
- Hammer head screw **part no. 21.1370/0** can be used
- Fitting end cap MW 45 GD-Z, **part no. 22.1024/1**
- Recommended locking torque: 20 Nm

MOUNTING ANGLE 45 SST

Part no. 21.0007/0

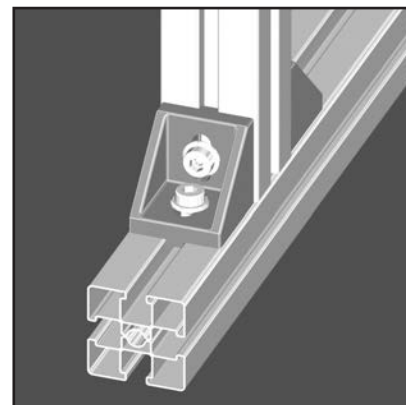
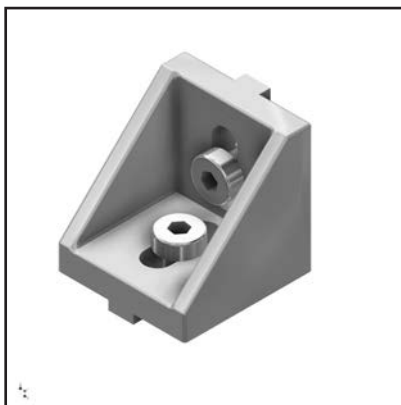
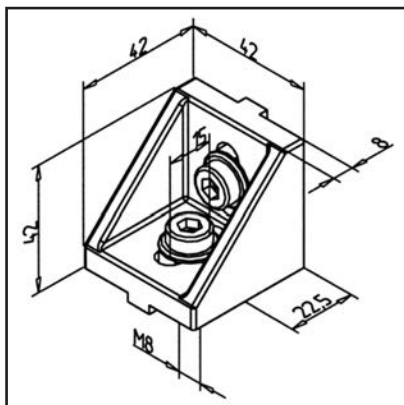
**TECHN. DATA / ITEMS SUPPLIED**

- Stainless steel, blasted
- Fastening kit
- Use on vertical struts **part no. 21.0007/7** (square nut with position-fixing)
- Weight = 0.255 kg/piece

APPLICATIONS

- General constructions, particularly for subsequent insertion of profiles into existing constructions
- Strengthening of profile constructions

ASSEMBLY

- Fasten to profile groove with supplied hardware
- Recommended locking torque: 20 Nm

MOUNTING ANGLE 30 R 90°

Part no.

21.2109/0

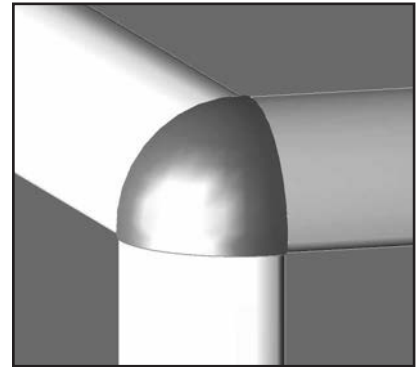
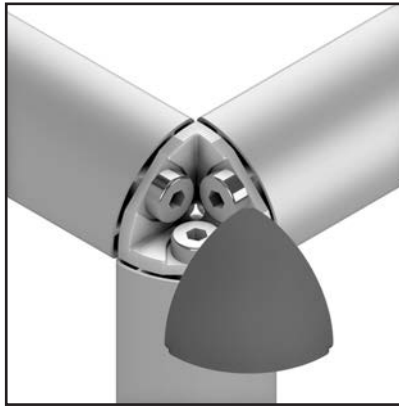
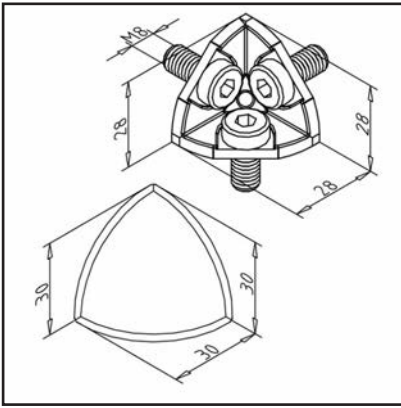

TECHN. DATA / ITEMS SUPPLIED

- Aluminium, Pressure die-casting, bright
- With fastening material steel, zinc plated
- End cap MW 30 R 90° **part no. 22.1143/1**
- Weight = 0.043 kg/piece

APPLICATIONS

- Corner fastening of profiles 30 R 90°
- Constructions for show cases, tables etc.

ASSEMBLY

- in the central bore of the profile with supplied hardware
- Clip the end cap

MOUNTING ANGLE 45 R 90°

Part no.

21.1710/1

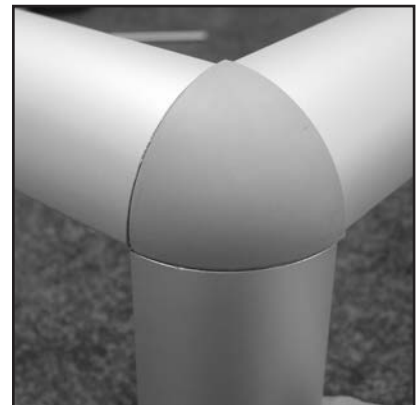
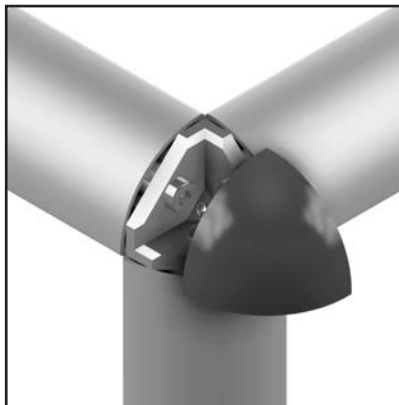
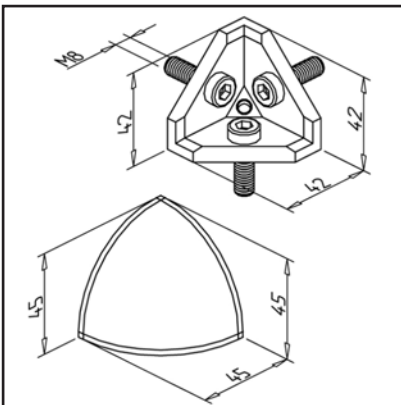

TECHN. DATA / ITEMS SUPPLIED

- Aluminium, Pressure die-casting, bright
- With fastening material steel, zinc plated
- End cap MW 45 R 90° **part no. 22.1033/1**
- Weight = 0.098 kg/piece

APPLICATIONS

- Corner fastening of profiles 45 R 90°
- Constructions for show cases, tables etc.

ASSEMBLY

- in the central bore of the profile with supplied hardware
- Clip the end cap

MOUNTING ANGLE 45°

Part no.

21.1708/1

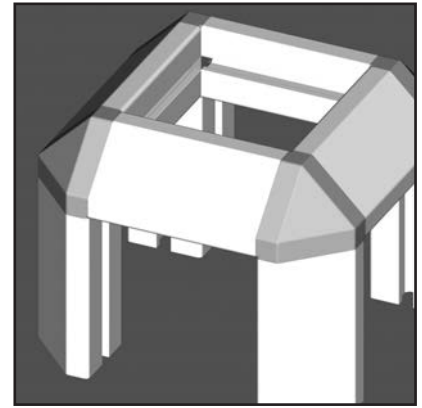
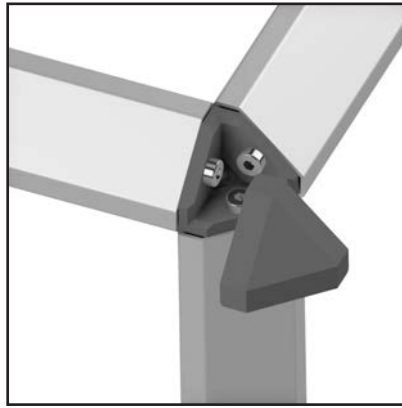
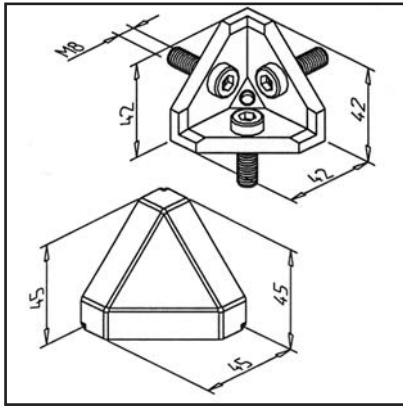
**TECHN. DATA / ITEMS SUPPLIED**

- Aluminium, Pressure die-casting, bright
- With fastening material steel, zinc plated
- End cap 45°/3, grey **part no. 22.1027/1**
- Weight = 0.107 kg/piece

APPLICATIONS

- Corner fastening of profiles 45 / 45°
- Constructions for show cases, tables etc.

ASSEMBLY

- in the central bore of the profile with supplied hardware
- Clip the end cap

MOUNTING ANGLE 45 G

Part no.

21.2503/1

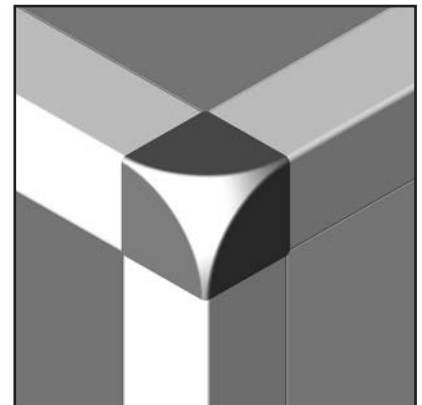
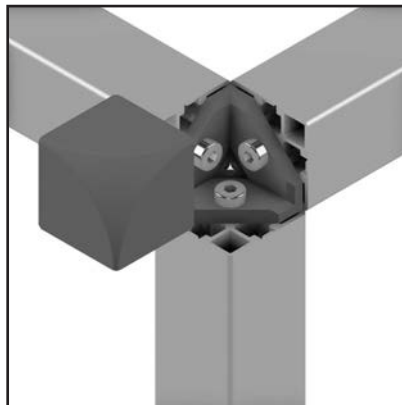
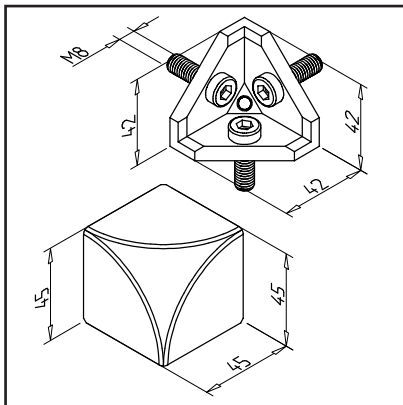
**TECHN. DATA / ITEMS SUPPLIED**

- Aluminium, Pressure die-casting, bright, grey
- With fastening material steel, zinc plated
- End cap MW 45/45/45 grey **part no. 22.1177/1**
- Weight = 0.121 kg/piece

APPLICATIONS

- Constructions for show cases, tables etc.
- Connection of profiles 45x45, preferably G-profile

ASSEMBLY

- Fasten to central profile bore with fixation material from delivery scope
- Clip the end cap

MOUNTING ANGLE 45 X 90 GD-Z

Part no. 21.1397/0

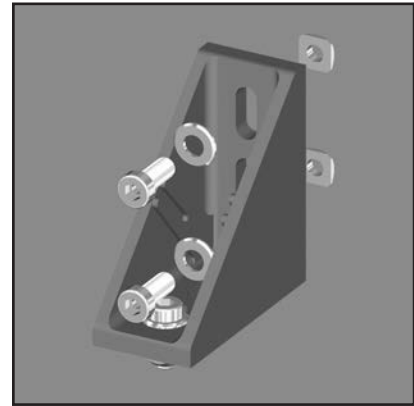
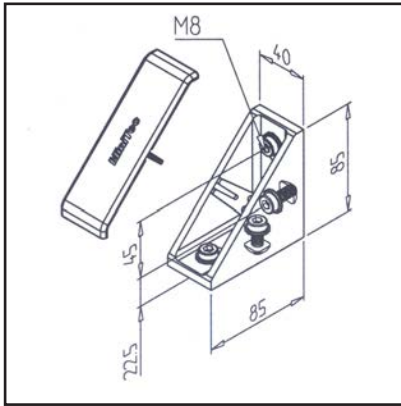

TECHN. DATA / ITEMS SUPPLIED

- Aluminium, Pressure die-casting, powder-coated, grey
- With fastening material steel, zinc plated
- Package size of 25 pieces **part no. 21.1397/025**
- **Conductive version part no. 21.1397/6**
- Use on vertical struts **part no. 21.1397/7** (square nut with position-fixing)
- Weight = 0.281 kg/piece

APPLICATIONS

- General constructions, particularly for subsequent insertion of profiles into existing constructions
- Fastening of surface elements, table tops
- Strengthening of profile constructions

ASSEMBLY

- Fasten to profile groove with supplied hardware
- Hammer head screw **part no. 21.1370/0** can be used
- Fitting end cap MW 45 x90 GD-Z, **part no. 22.0998/1**
- Recommended locking torque: 20 Nm

MOUNTING ANGLE 90 GD-Z

Part no. 21.0978/0

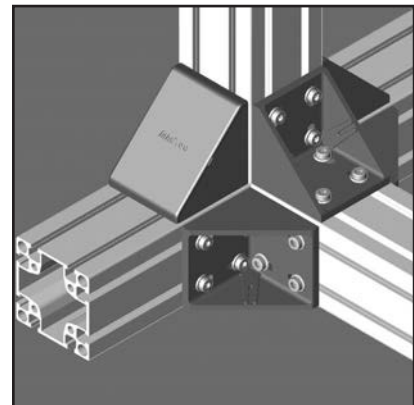
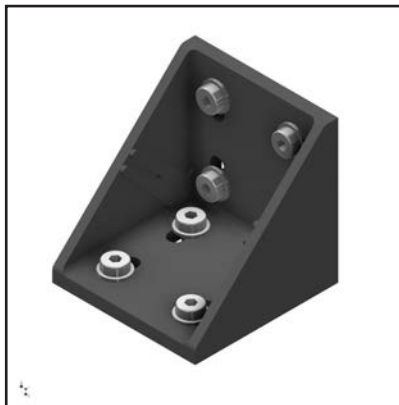
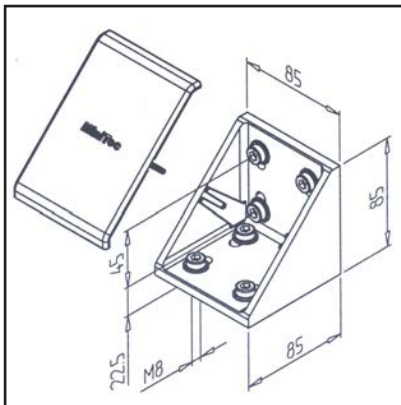

TECHN. DATA / ITEMS SUPPLIED

- Aluminium, Pressure die-casting, powder-coated, grey
- With fastening material steel, zinc plated
- Package size of 25 pieces **part no. 21.0978/025**
- **Conductive version part no. 21.0978/6**
- Use on vertical struts **part no. 21.0978/7** (square nut with position-fixing)
- Weight = 0.497 kg/piece

APPLICATIONS

- For profiles 90 and 180
- General constructions, particularly for subsequent insertion of profiles into existing constructions
- Strengthening of profile constructions

ASSEMBLY

- Fasten to profile groove with supplied hardware
- Hammer head screw **part no. 21.1370/0** can be used
- Matching cap MW 90 GD-Z **part-No. 22.0999/1**
- Recommended locking torque: 20 Nm

CORNER CONNECTION 90 R 90°

Part no.

21.2199/0

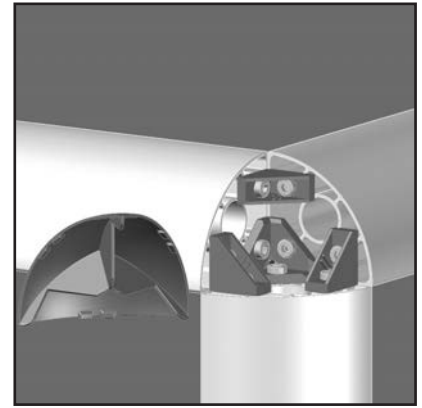
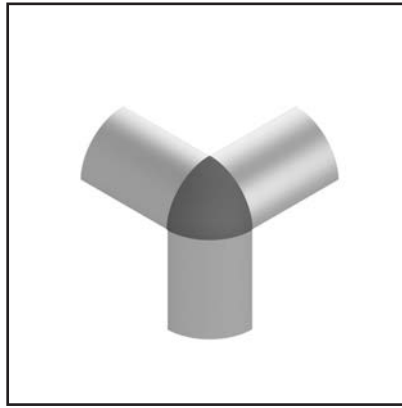
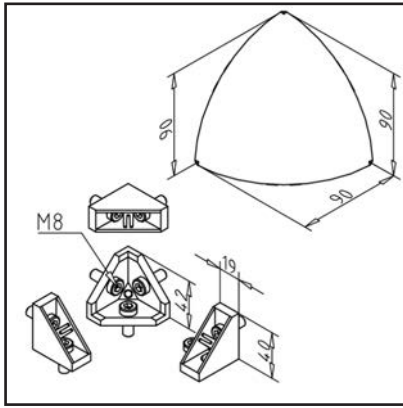
**TECHN. DATA / ITEMS SUPPLIED**

- Aluminium, Pressure die-casting, bright
- With fastening material steel, zinc plated
- End cap MW 90 R 90° **part no. 22.0980/1**
- Angle 45°, **part no. 21.1708/2**
- Mounting bracket 19 GD-Z, **part no. 21.2078/2**
- Weight = 0.267 kg/piece

APPLICATIONS

- Corner connections of profiles 90 R 90°
- Constructions for show cases, tables etc.

ASSEMBLY

- Fasten to central profile bore with fixation material from delivery scope
- Clip the end cap

T-SHEET SST

Part no.

21.0019/0

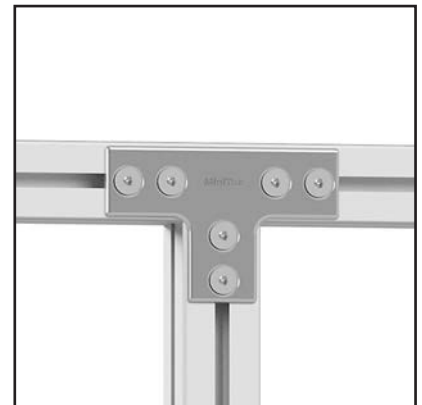
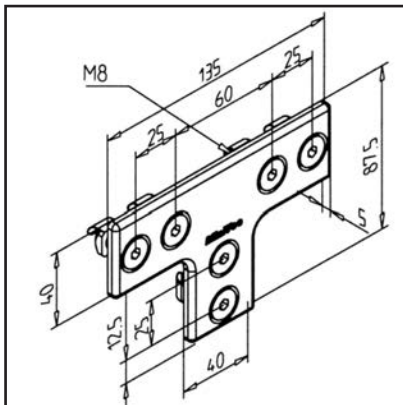
**TECHN. DATA / ITEMS SUPPLIED**

- Stainless steel, blasted
- Fastening kit
- Weight = 0.259 kg/piece

APPLICATIONS

- Strengthening of profile constructions

ASSEMBLY

- Attach to the profile with supplied hardware
- Use power-lock fasteners if tractive forces appear

ANGLE-SHEET SST

Part no.

21.0018/0

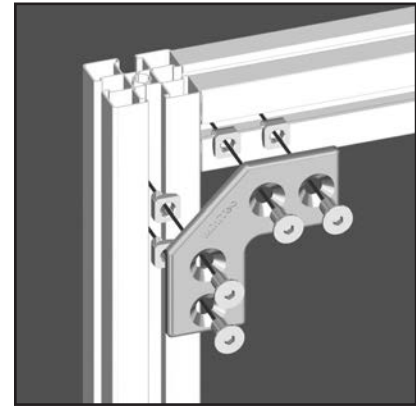
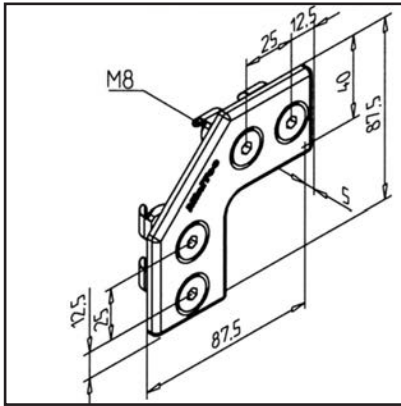

TECHN. DATA / ITEMS SUPPLIED

- Stainless steel, blasted
- Fastening kit
- Weight = 0.163 kg/piece

APPLICATIONS

- Strengthening of profile constructions
- Also suitable for cross joints (double application)

ASSEMBLY

- Attach to the profile with supplied hardware
- Use power-lock fasteners if tractive forces appear

MULTI CONNECTOR 30

Part no.

22.1140/0

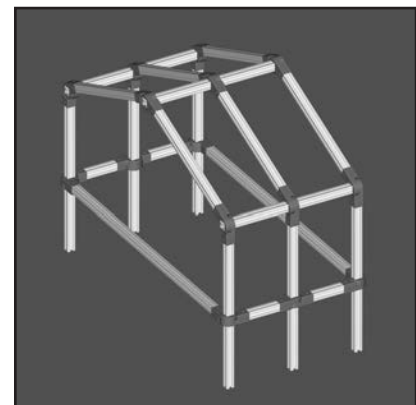
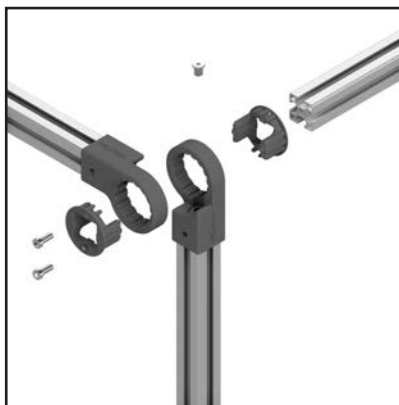
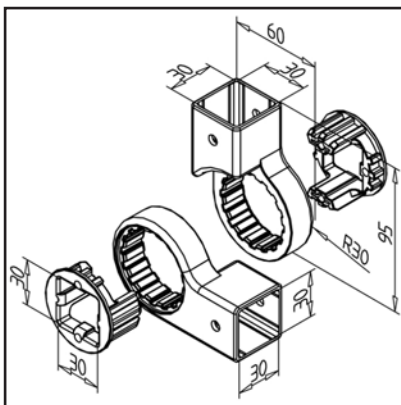

TECHN. DATA / ITEMS SUPPLIED

- ABS, Injection Mould, grey
- With fastening material steel, zinc plated
- Weight = 0.135 kg/piece

APPLICATIONS

- Easy connection for profiles
- Angle adjustable in 22,5° raster

ASSEMBLY

- Fix swivel arm front to profile
- Insert socket from the side
- Insert other profile into socket and position it
- Secure with 2 cylinder screws against moving

ADAPTER G32 / G32

Part no.

21.0954/0

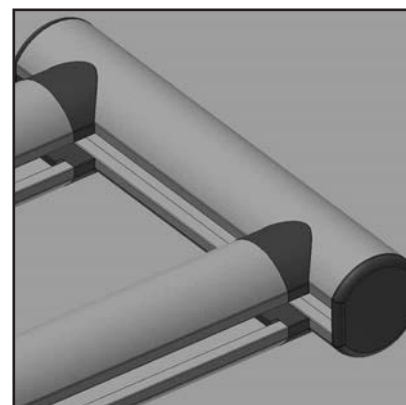
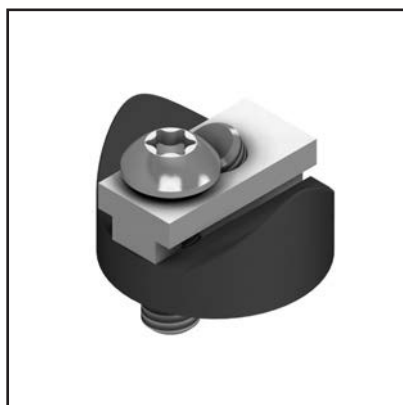
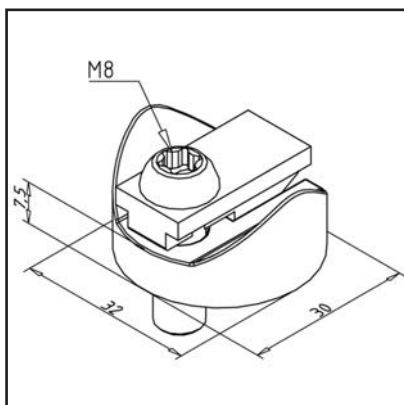
**TECHN. DATA / ITEMS SUPPLIED**

- Aluminium, Pressure die-casting, powder-coated, grey
- With fastening material steel, zinc plated
- Weight = 0.041 kg/piece

APPLICATIONS

- For connection of handle profile 32 with handle profile 32

ASSEMBLY

- Screw on profile face and fasten with power-lock fastener
- Push in cross direction profile and attach it to the desired location

ADAPTER G32 / 30 X 30

Part no.

21.0955/0

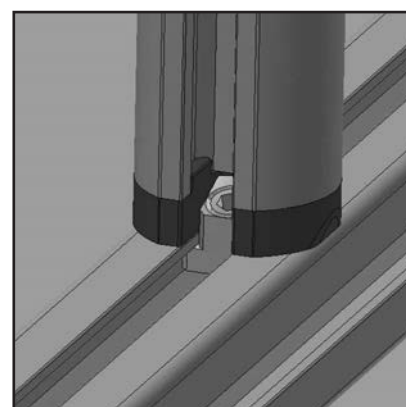
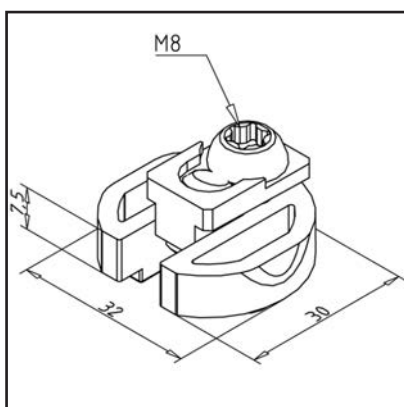
**TECHN. DATA / ITEMS SUPPLIED**

- Aluminium, Pressure die-casting, powder-coated, grey
- With fastening material steel, zinc plated
- Weight = 0.032 kg/piece

APPLICATIONS

- For connection of handle profile 32 with profiles of width 30

ASSEMBLY

- Screw on profile face and fasten with power-lock fastener
- Push in cross direction profile and attach it to the desired location

ADAPTER 30 X 30 / G32

Part no.

21.0953/0

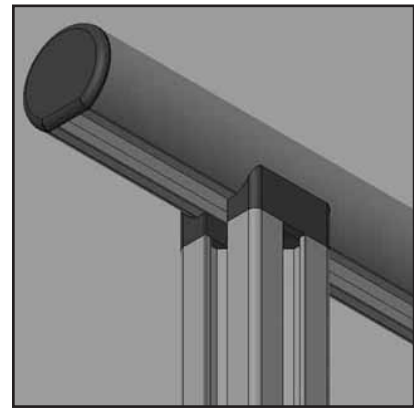
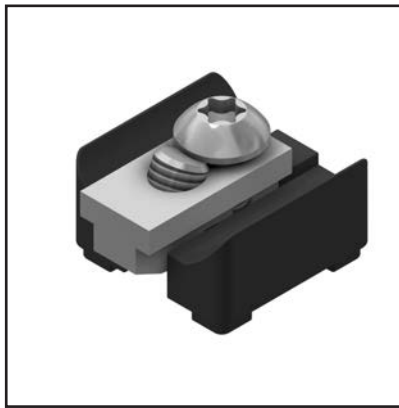
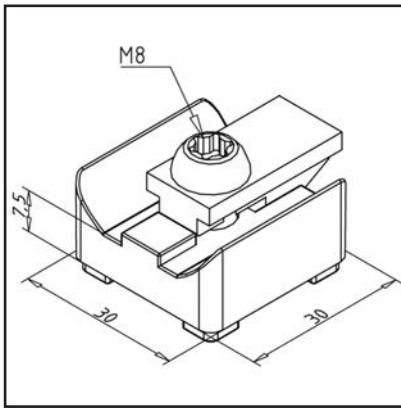

TECHN. DATA / ITEMS SUPPLIED

- Aluminium, Pressure die-casting, powder-coated, grey
- With fastening material steel, zinc plated
- Weight = 0.046 kg/piece

APPLICATIONS

- For connection of profile 30 x 30 with handle profile 32

ASSEMBLY

- Screw on profile face and fasten with power-lock fastener
- Push in cross direction profile and attach it to the desired location

CONNECTING BAR

Part no.

21.1113/0

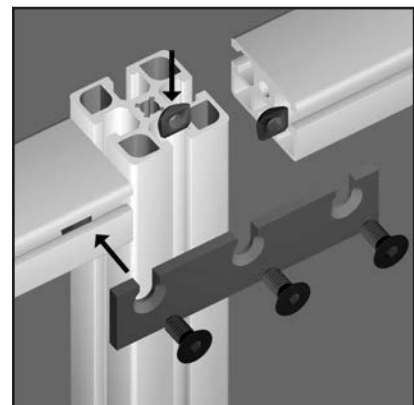
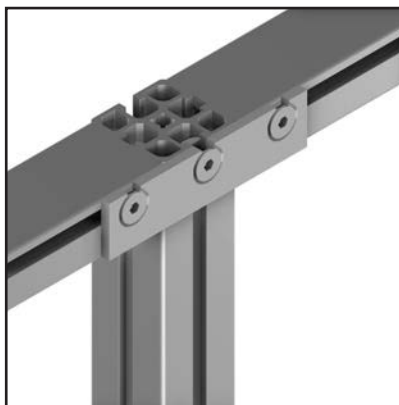
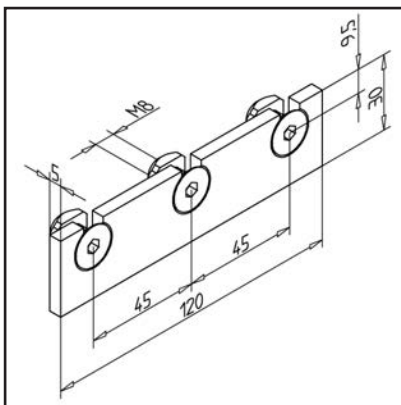

TECHN. DATA / ITEMS SUPPLIED

- Steel, galvanized
- With fastening material steel, zinc plated
- Weight = 0.156 kg/piece

APPLICATIONS

- Connection of different profiles
- Retrofitting profiles

ASSEMBLY

- Fasten to profile groove with supplied hardware
- No machining required

PROTECTIVE FIELD SUSPENSION 45 ST

Part no.

21.1404/0

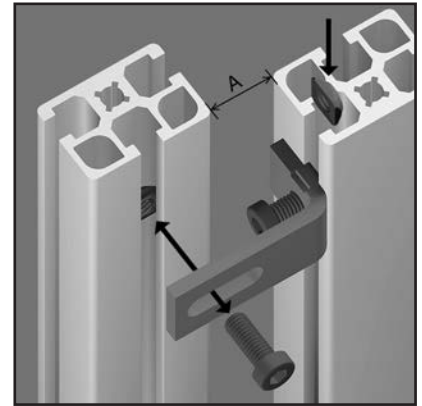
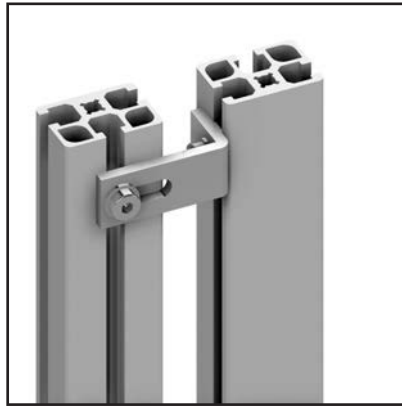
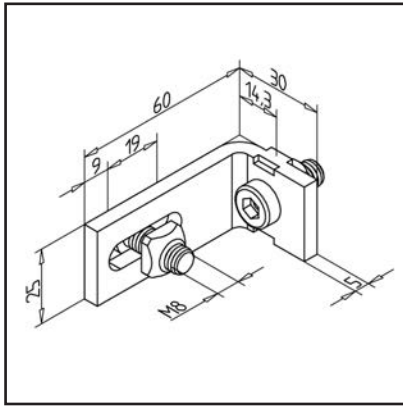
**TECHN. DATA / ITEMS SUPPLIED**

- Steel, galvanized
- With fastening material steel, zinc plated
- Weight = 0.104 kg/piece

APPLICATIONS

- Fixation of guard units from profile 45 x 32
- Usable in frames made from any profile
- The protective field flush fits to the column

ASSEMBLY

- Fasten to profile groove with supplied hardware
- No machining required
- First attach the brackets to the standing profile, then connect the protective field from the rear to the brackets
- A = 10 mm - 28 mm

PROTECTIVE FIELD SUSPENSION 19

Part no.

21.1399/0

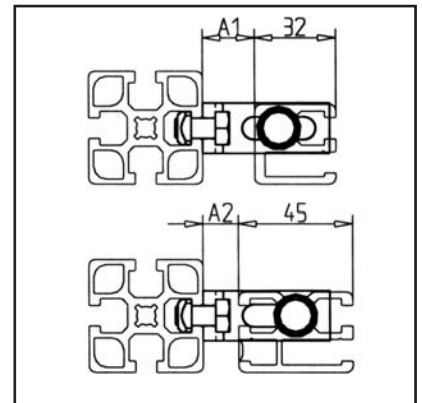
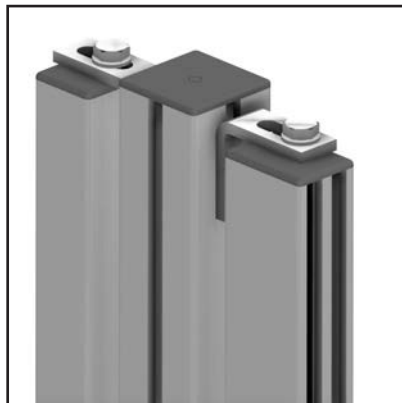
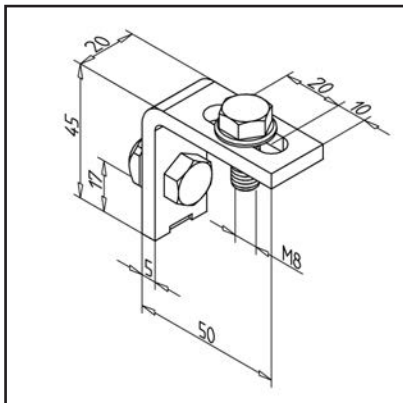
**TECHN. DATA / ITEMS SUPPLIED**

- Steel, galvanized
- With fastening material steel, zinc plated
- Weight = 0.089 kg/piece

APPLICATIONS

- Fastening protective fields from clamping profile 32 x 32, 45 x 32 or standard profiles
- Attachment of protective fields at any angle
- When using clamping profile 32x32 use end cap **part no. 22.1032/3**
- When using clamping profile 45x32 use end cap **part no. 22.1046/3**

ASSEMBLY

- Spread screw threads M8 x 20 into the profile ending of the protective field
- Install protective field suspension on posts
- Fix guard with screws of fastening kit
- Alternatively: For very fast assembly, the lower two threads can be fitted with the retaining pin 25 **part no. 21.1758/0**. Screw fastening only on the two upper threads
- A1 = 10.5 mm - 30.5 mm A2 = 10.5 mm - 17.5 mm

PROTECTIVE FIELD SUSPENSION 45 AL

Part no.

21.1407/0

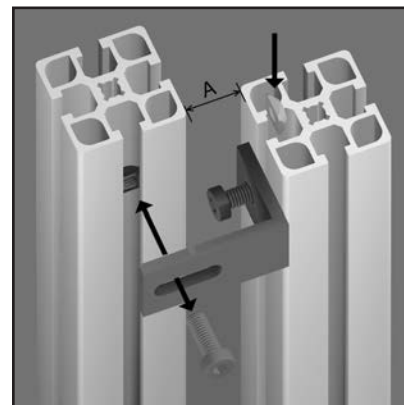
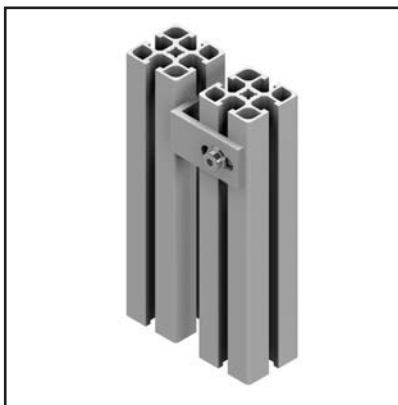
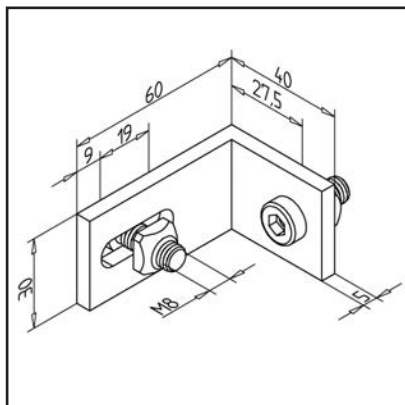

TECHN. DATA / ITEMS SUPPLIED

- Aluminium, anodized E6/EV1
- With fastening material steel, zinc plated
- Weight = 0.068 kg/piece

APPLICATIONS

- Fixation of guard units from profile 45 x 45
- Usable in frames made from any profile
- The protective field flush fits to the column

ASSEMBLY

- Fasten to profile groove with supplied hardware
- No machining required
- First attach the brackets to the standing profile, then connect the protective field from the rear to the brackets
- A = 10 mm - 28 mm

PROTECTIVE FIELD SUSPENSION GD-K

Part no.

21.0008/0

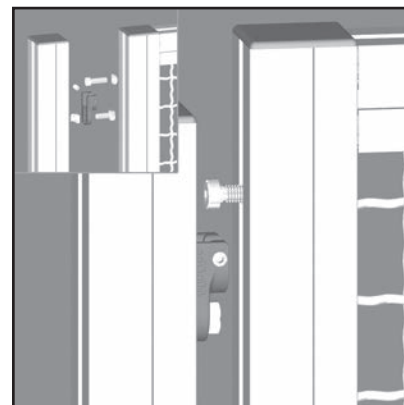
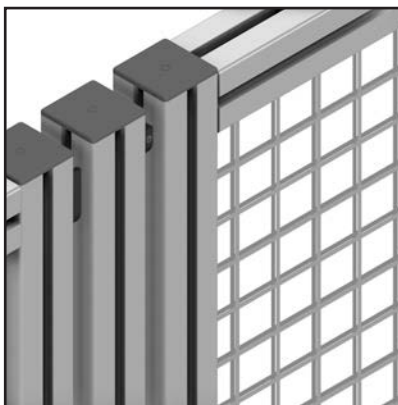
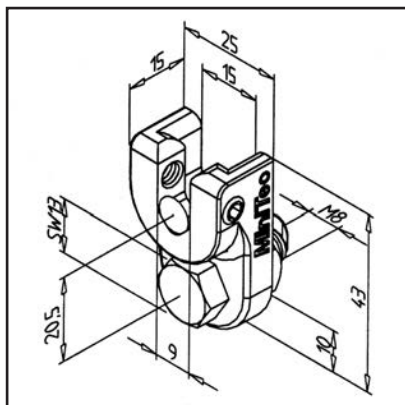

TECHN. DATA / ITEMS SUPPLIED

- Aluminium, Pressure die-casting, powder-coated, grey
- With fastening material steel, zinc plated
- Weight = 0.039 kg/piece

APPLICATIONS

- Guards from all profiles
- Movable flaps
- It is also possible to mount the guards at the front when fitting the suspensions to the front of the post

ASSEMBLY

- Fasten protective field hanger assembly in place on columns
- Guard unit with cylinder screws M8 x 25 furnished
- Hang the guard in place, and tighten the set screw using an Allen key from the rear
- A = 16 mm ± 0.75
- **Guard cannot be removed from outside**

PROTECTIVE FIELD SUSPENSION WITH ADJUSTABLE ANGLE

Part no.

21.1403/0

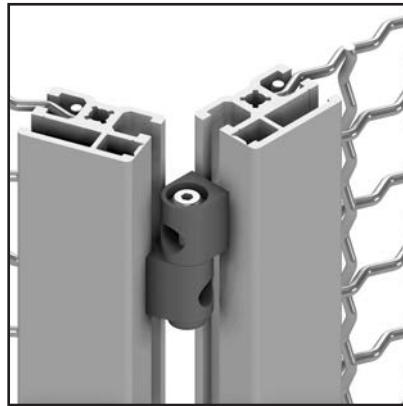
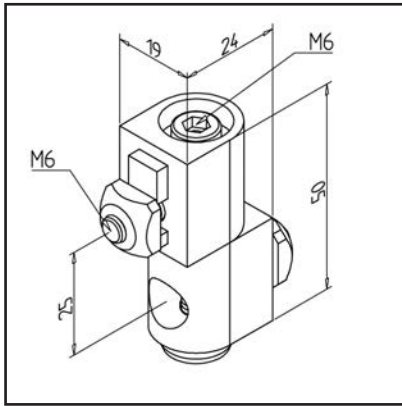

TECHN. DATA / ITEMS SUPPLIED

- Aluminium, Pressure die-casting, powder-coated, grey
- With fastening material steel, zinc plated
- Weight = 0.114 kg/piece

APPLICATIONS

- Connection of profile support under preferred angle
- Installation of safety fence elements at any angle

ASSEMBLY

- Assemble and align lower halves onto posts
- Assemble and mount upper halves on guard unit
- Insert the cylinder head screw and tighten it with key 4 A/F. The inserted hexagon nut in the lower fixing half is secured against torsion

CONNECTING PLATE 30 X 60

Part no.

21.2113/0

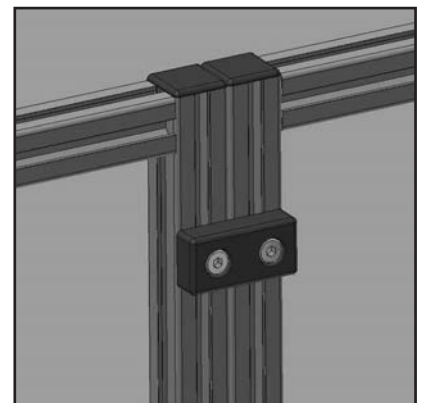
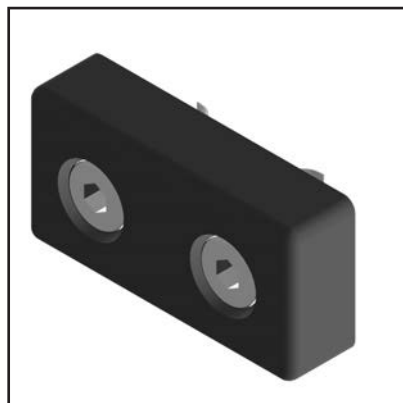
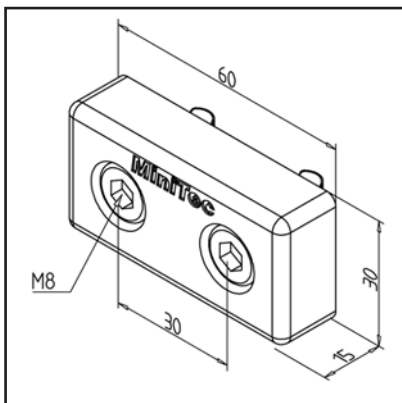

TECHN. DATA / ITEMS SUPPLIED

- Aluminium, Pressure die-casting, powder-coated, grey
- With fastening material steel, zinc plated
- Weight = 0.085 kg/piece

APPLICATIONS

- Connection of two guards without gap
- Strengthening of guard units
- Connection of pre-assembled modules

ASSEMBLY

- Install to groove of protective field and posts with supplied hardware

CONNECTING PLATE 90 X 32

Part no.

21.1346/0

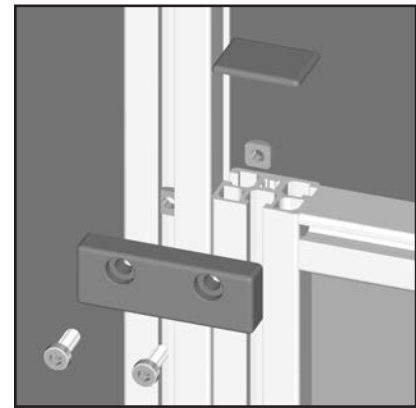
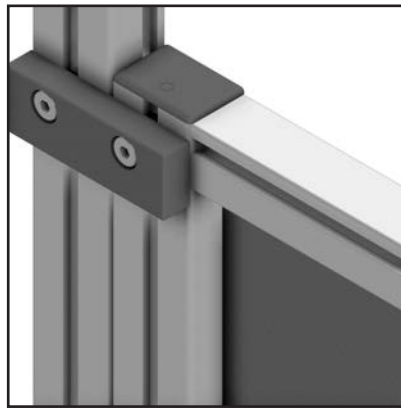
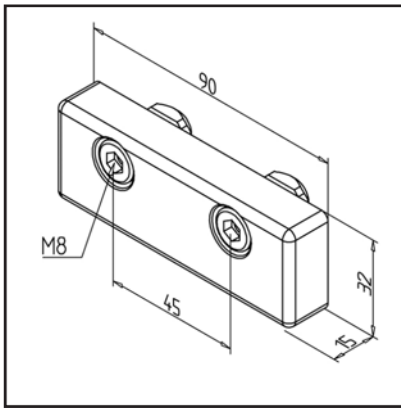

TECHN. DATA / ITEMS SUPPLIED

- Aluminium, Pressure die-casting, powder-coated, grey
- With fastening material steel, zinc plated
- Weight = 0.136 kg/piece

APPLICATIONS

- Connection of two guards without gap
- Strengthening of guard units
- Connection of pre-assembled modules

ASSEMBLY

- Install to groove of protective field and posts with supplied hardware

CONNECTING PLATE 45 X 90

Part no.

21.1472/0

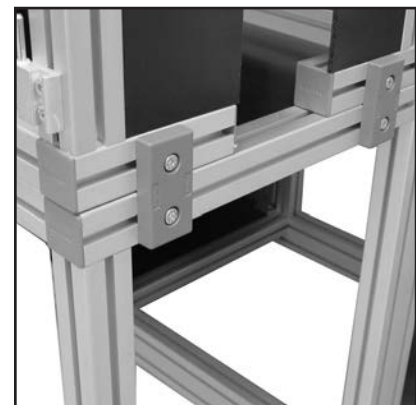
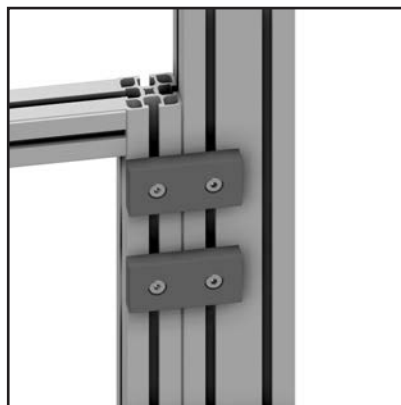
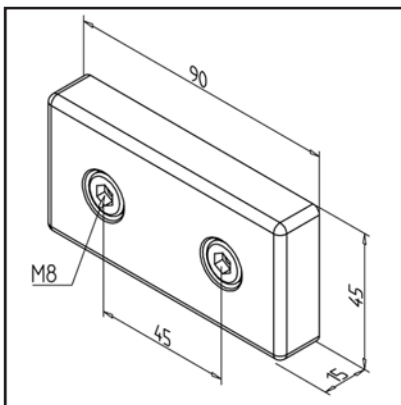

TECHN. DATA / ITEMS SUPPLIED

- Aluminium, Pressure die-casting, powder-coated, grey
- With fastening material steel, zinc plated
- Weight = 0.182 kg/piece

APPLICATIONS

- Connection of two guards without gap
- Strengthening of guard units
- Connection of pre-assembled modules

ASSEMBLY

- Install to groove of protective field and posts with supplied hardware

CONNECTING PLATE 90 X 90

Part no.

21.1473/0

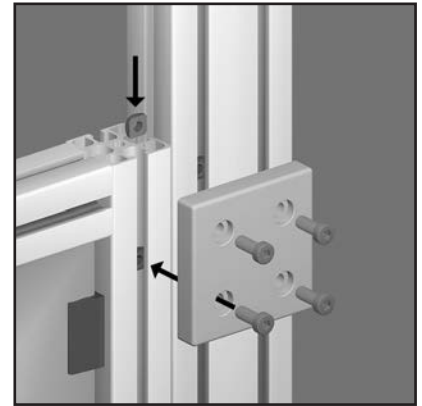
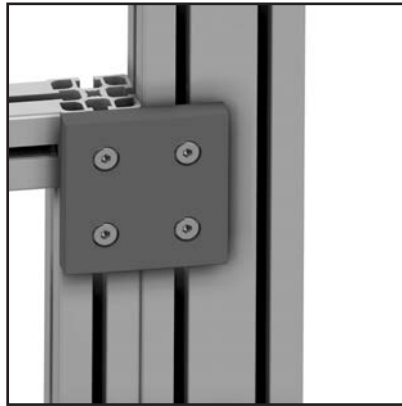
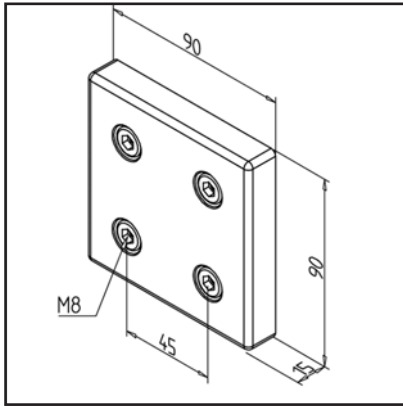
**TECHN. DATA / ITEMS SUPPLIED**

- Aluminium, Pressure die-casting, powder-coated, grey
- With fastening material steel, zinc plated
- Weight = 0.366 kg/piece

APPLICATIONS

- Connection of two guards without gap
- Strengthening of guard units
- Connection of pre-assembled modules

ASSEMBLY

- Install to groove of protective field and posts with supplied hardware

CLAMPING CLAW

Part no.

21.1027/0

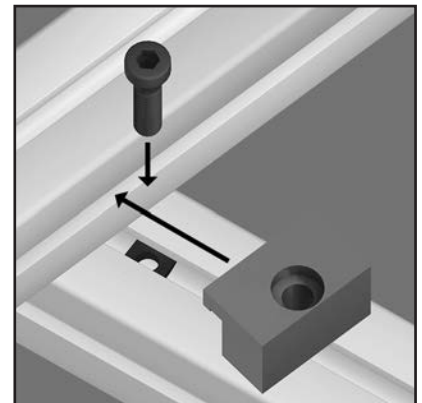
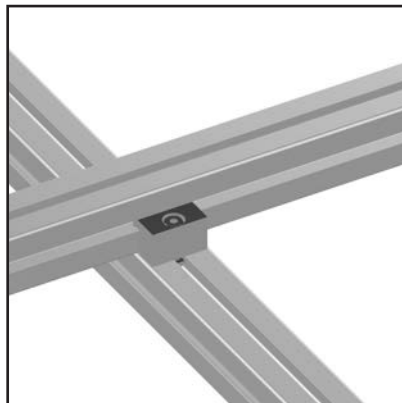
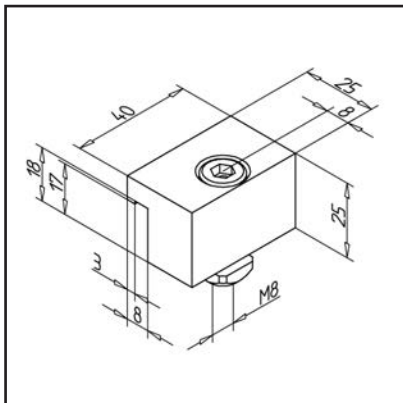
**TECHN. DATA / ITEMS SUPPLIED**

- Aluminium, anodized E6/EV1
- With fastening material steel, zinc plated
- Weight = 0.063 kg/piece

APPLICATIONS

- Parallel connection of profiles at various angles

ASSEMBLY

- Fasten to profile groove with supplied hardware
- No machining required

DETACHABLE HINGE 19

Part no.

21.1100/0

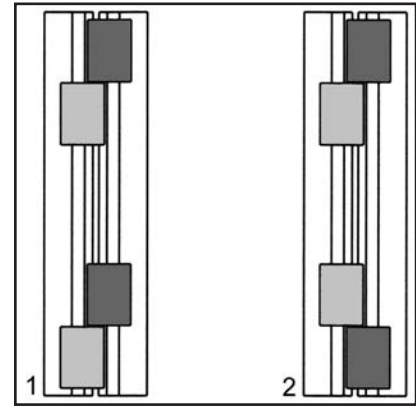
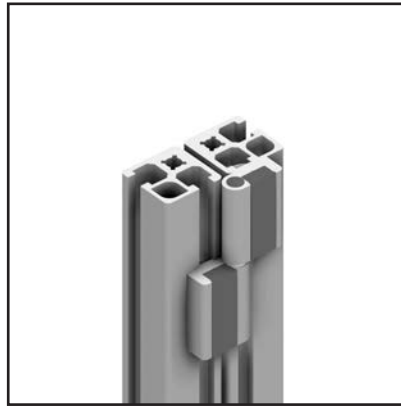
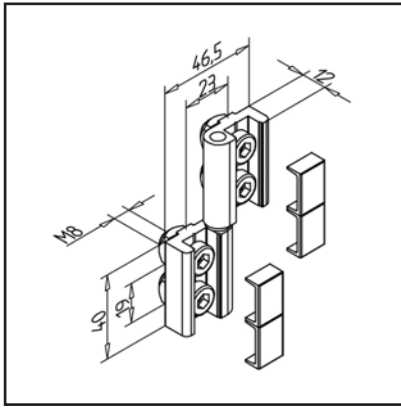

TECHN. DATA / ITEMS SUPPLIED

- Aluminium, anodized E6/EV1
- with stainless steel shaft
- With fastening material steel, zinc plated
- End caps
- Spring plate design **part no. 21.1100/7**
- load capacity up to 400 N
- Weight = 0.110 kg/piece

APPLICATIONS

- Detachable doors, hatches, surface elements in a vertical arrangement
- If the hinges are arranged in the opposite direction, non-detachable and horizontally mounted structures can also be produced
- Connection of profiles 19 at various angles

ASSEMBLY

- Fasten to profile groove with supplied hardware.
- For fixing directly on surface elements or on profile surfaces we deliver hinge 19 without fixing element **part no. 21.1100/2**
- 1: lift removable
- 2: Arrangement is not detachable

DETACHABLE HINGE 32

Part no.

21.1095/0

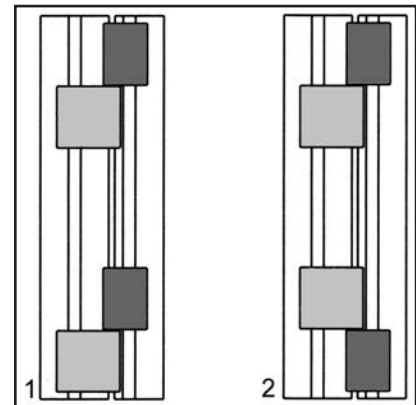
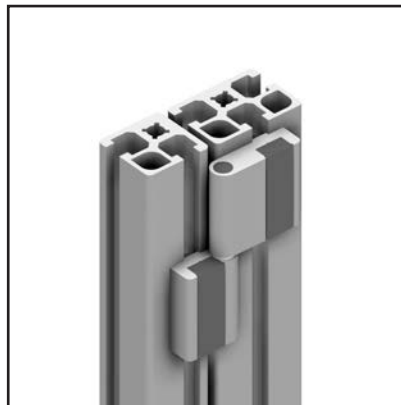
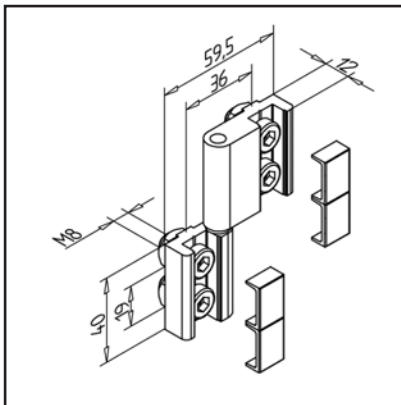

TECHN. DATA / ITEMS SUPPLIED

- Aluminium, anodized E6/EV1
- with stainless steel shaft
- With fastening material steel, zinc plated
- End caps
- **Order with position fixing nuts, part no. 21.1095/7**
- load capacity up to 400 N
- Weight = 0.134 kg/piece

APPLICATIONS

- Detachable doors, hatches, moving parts on profiles 32
- If the hinges are arranged in the opposite direction, non-detachable and horizontally mounted structures can also be produced
- Connecting profiles 19, 32 and 45 at any angle

ASSEMBLY

- Fasten to profile groove with supplied hardware.
- For fixing directly on surface elements or on profile surfaces we deliver hinge 32 without fixing element **part no. 21.1095/2**
- 1: lift removable
- 2: Arrangement is not detachable

DETACHABLE HINGE 45

Part no.

21.1096/0

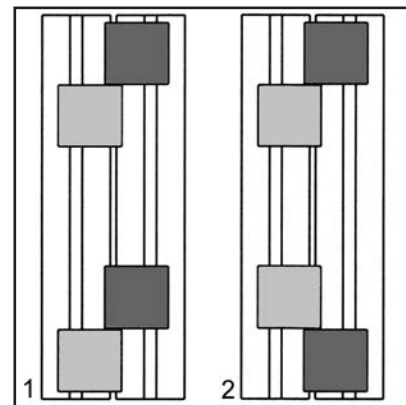
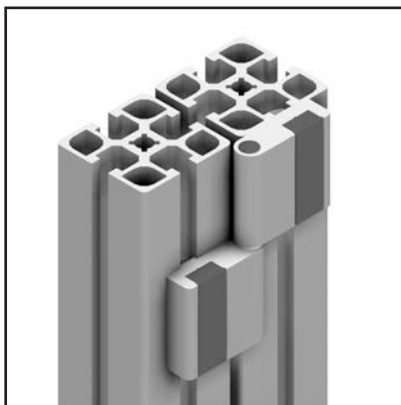
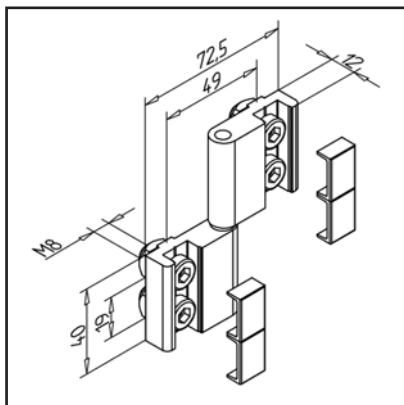
**TECHN. DATA / ITEMS SUPPLIED**

- Aluminium, anodized E6/EV1
- with stainless steel shaft
- With fastening material steel, zinc plated
- End caps
- Order with position fixing nuts, **part no. 21.1096/7**
- load capacity up to 400 N
- Weight = 0.151 kg/piece

APPLICATIONS

- Detachable doors, hatches, moving parts on profiles 45
- Connection of profiles 45 at various angles
- Suspension of protective fields
- If the hinges are arranged in the opposite direction, non-detachable and horizontally mounted structures can also be produced

ASSEMBLY

- Fasten to profile groove with supplied hardware.
- For fixing directly on surface elements or on profile surfaces we deliver hinge 45 without fixing element **part no. 21.1096/2**
- 1: lift removable
- 2: Arrangement is not detachable

DETACHABLE HINGE L 19/30

Part no.

21.1374/0

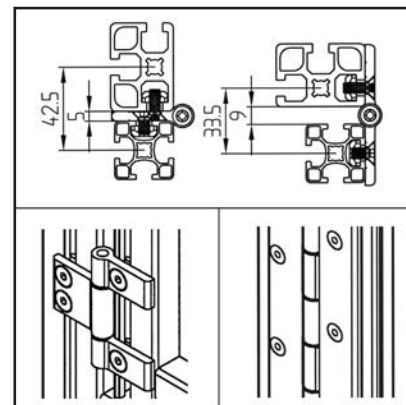
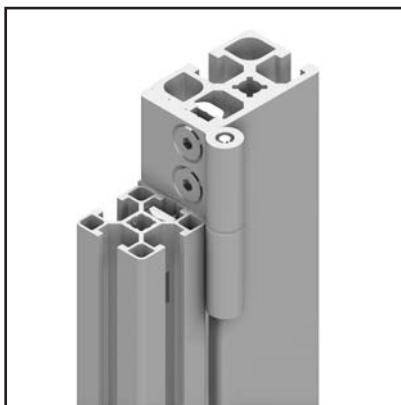
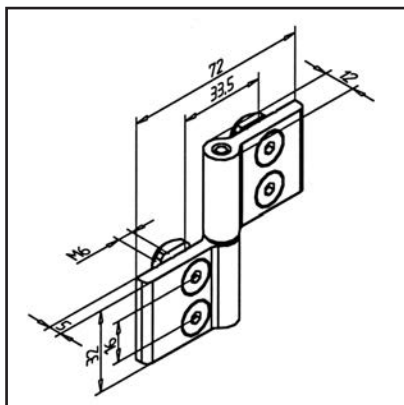
**TECHN. DATA / ITEMS SUPPLIED**

- Aluminium, anodized E6/EV1
- with stainless steel shaft
- With fastening material steel, zinc plated
- load capacity up to 400 N
- Weight = 0.089 kg/piece

APPLICATIONS

- Detachable doors, hatches, moving parts to profiles 19, 32 and 45
- If the hinges are arranged in the opposite direction, non-detachable and horizontally mounted structures can also be produced
- Connecting profiles 19 and 30 at any angle

ASSEMBLY

- Fasten to profile groove with supplied hardware.
- The hinge profile 5GB **part no. 20.0093/0** (not anodized) is available for the production of hinges in variable lengths and bore spacings as well as piano hinges

DETACHABLE HINGE L 30/30

Part no.

21.1376/0

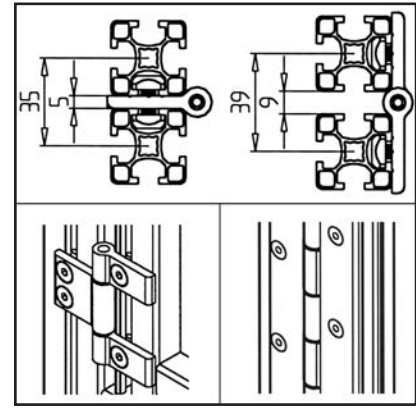
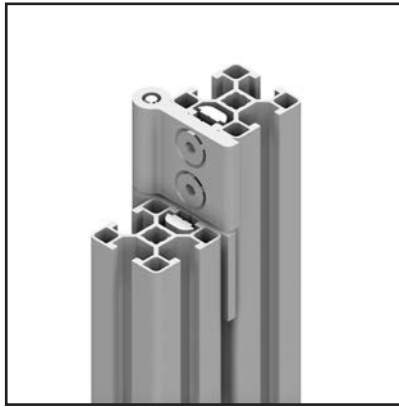
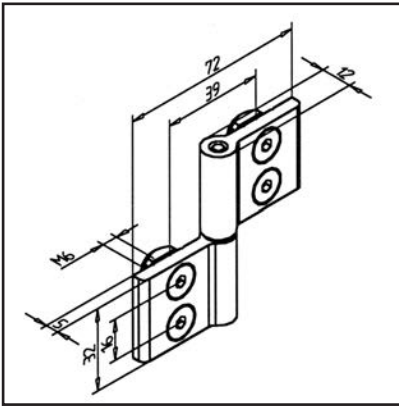

TECHN. DATA / ITEMS SUPPLIED

- Aluminium, anodized E6/EV1
- with stainless steel shaft
- With fastening material steel, zinc plated
- load capacity up to 400 N
- Weight = 0.089 kg/piece

APPLICATIONS

- Detachable doors, hatches, movable attachments
- If the hinges are arranged in the opposite direction, non-detachable and horizontally mounted structures can also be produced
- Connection of profiles 30 under preferred angle

ASSEMBLY

- Fasten to profile groove with supplied hardware.
- The hinge profile 5GB **part no. 20.0093/0** (not anodized) is available for the production of hinges in variable lengths and bore spacings as well as piano hinges

DETACHABLE HINGE L 30/45

Part no.

21.1377/0

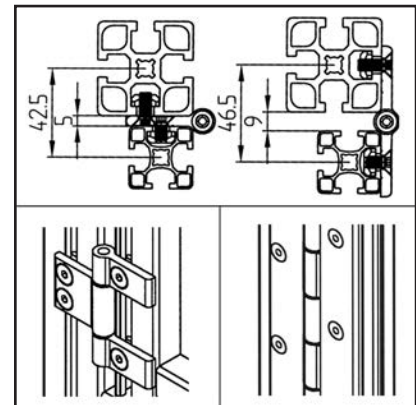
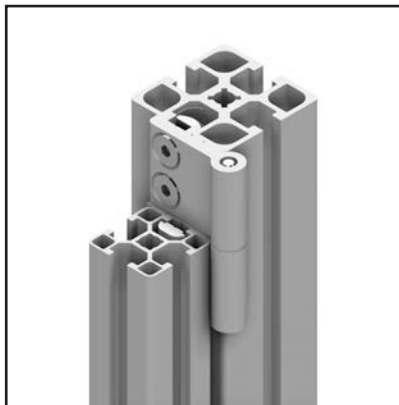
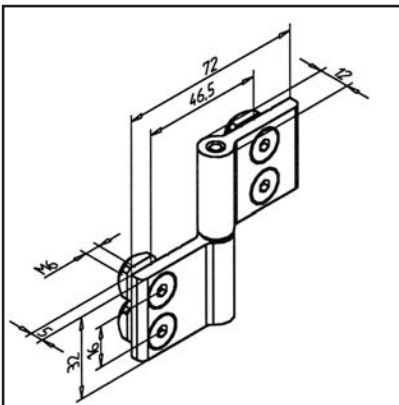

TECHN. DATA / ITEMS SUPPLIED

- Aluminium, anodized E6/EV1
- with stainless steel shaft
- With fastening material steel, zinc plated
- load capacity up to 400 N
- Weight = 0.089 kg/piece

APPLICATIONS

- Detachable doors, hatches, movable attachments
- If the hinges are arranged in the opposite direction, non-detachable and horizontally mounted structures can also be produced
- Connection of profiles 30 and 45 at various angles

ASSEMBLY

- Fasten to profile groove with supplied hardware.
- The hinge profile 5GB **part no. 20.0093/0** (not anodized) is available for the production of hinges in variable lengths and bore spacings as well as piano hinges

DETACHABLE HINGE L 45/45

Part no.

21.1378/0

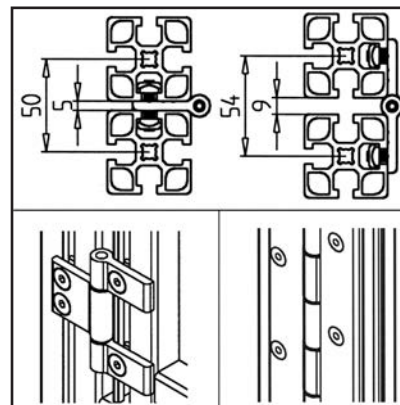
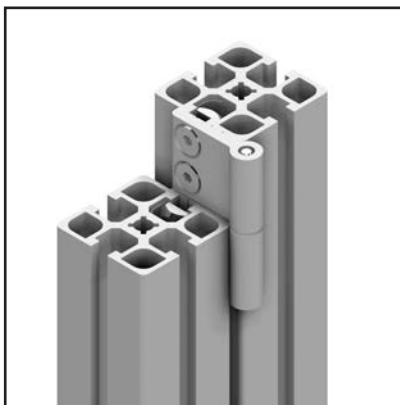
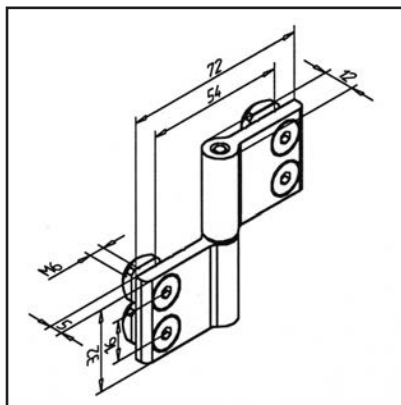

TECHN. DATA / ITEMS SUPPLIED

- Aluminium, anodized E6/EV1
- with stainless steel shaft
- With fastening material steel, zinc plated
- load capacity up to 400 N
- Weight = 0.089 kg/piece

APPLICATIONS

- Detachable doors, hatches, moving parts on profiles 45
- Suspension of protective fields
- If the hinges are arranged in the opposite direction, non-detachable and horizontally mounted structures can also be produced
- Connection of profiles 45 at various angles

ASSEMBLY

- Fasten to profile groove with supplied hardware.
- The hinge profile 5GB **part no. 20.0093/0** (not anodized) is available for the production of hinges in variable lengths and bore spacings as well as piano hinges

DOOR HINGE SMALL

Part no.

21.0973/0

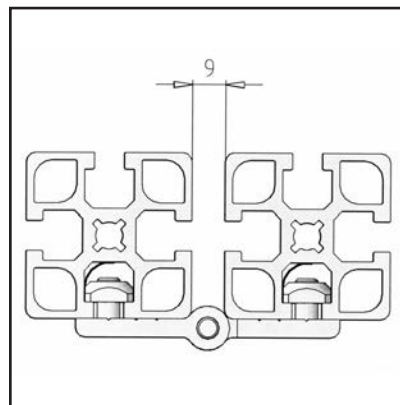
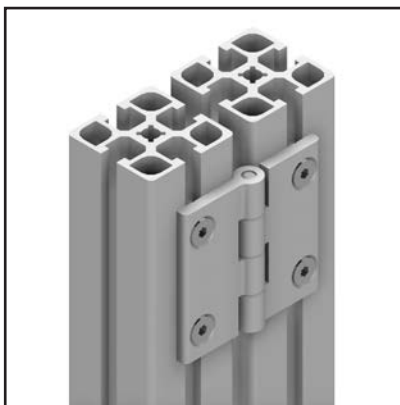
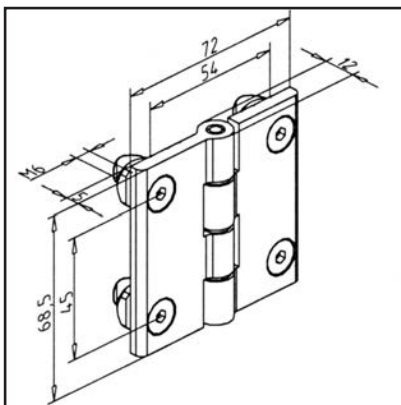

TECHN. DATA / ITEMS SUPPLIED

- Aluminium, anodized E6/EV1
- with stainless steel shaft
- With fastening material steel, zinc plated
- Weight = 0.120 kg/piece

APPLICATIONS

- Suitable for large doors and lids
- Guard units
- Connection of profiles at various angles

ASSEMBLY

- Screw tight to the profile groove with supplied hardware

DOOR HINGE LARGE

Part no.

21.0970/0

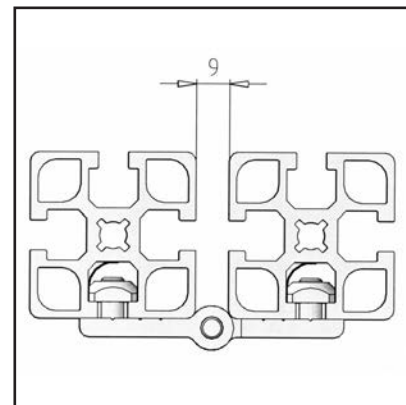
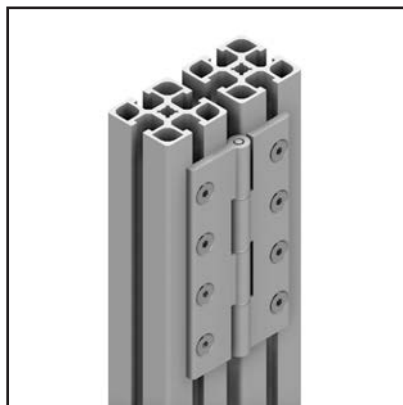
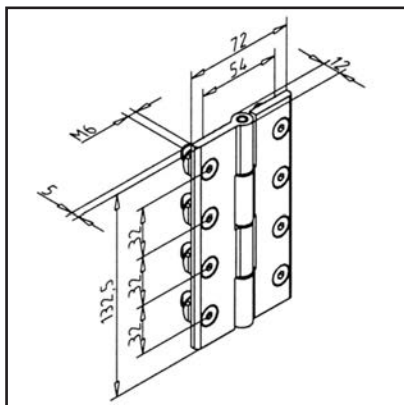
**TECHN. DATA / ITEMS SUPPLIED**

- Aluminium, anodized E6/EV1
- with stainless steel shaft
- With fastening material steel, zinc plated
- Weight = 0.235 kg/piece

APPLICATIONS

- Suitable for large doors and lids
- Guard units
- Connection of profiles at various angles

ASSEMBLY

- Screw tight to the profile groove with supplied hardware

FOLDING HINGE 19 S

Part no.

21.1044/0

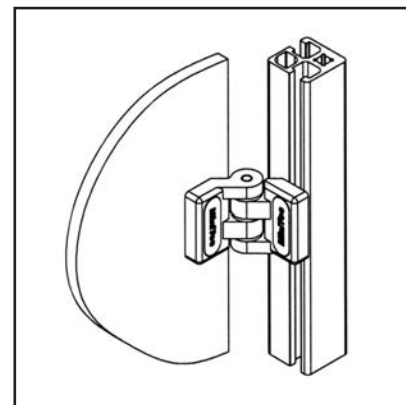
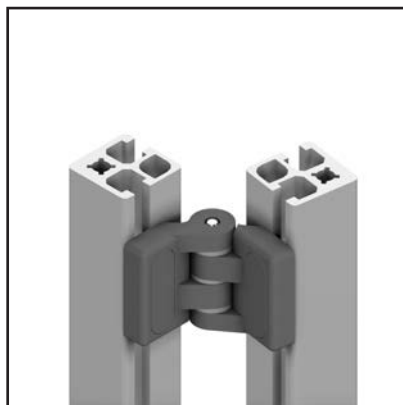
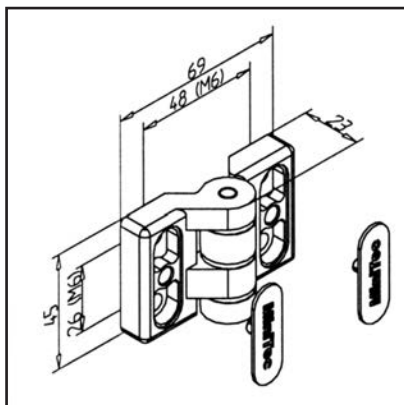
**TECHN. DATA / ITEMS SUPPLIED**

- Aluminium, Pressure die-casting, powder-coated, grey
- Hinge pin, steel, galvanised
- End caps
- Without fastening kit
- load capacity up to 600 N
- Weight = 0.100 kg/piece

APPLICATIONS

- Suitable for larger doors and hatches of profiles 19 or 32
- Guard units
- Connection of profiles 19 and 32 at any angle

ASSEMBLY

- Fasten hinge halves each with 2 screws M6 x 18 and 2 square nut on profile, or fasten directly with screws on to surface elements according to material strength
- For heavy-duty applications use multiple hinges
- Swivel range up to 270°

FOLDING HINGE 32 S

Part no.

21.1055/0

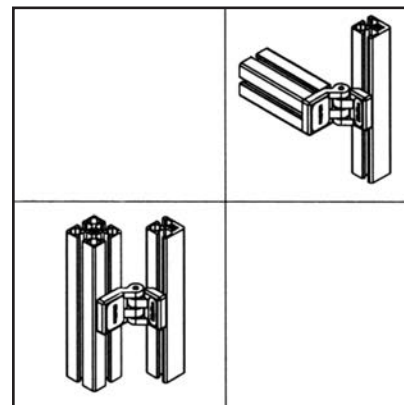
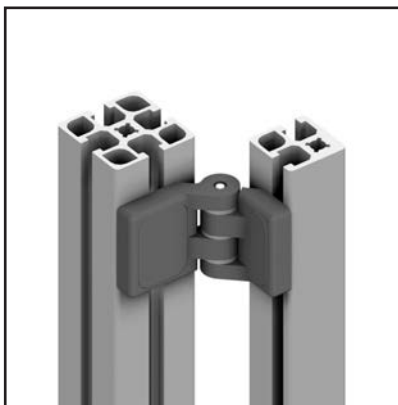
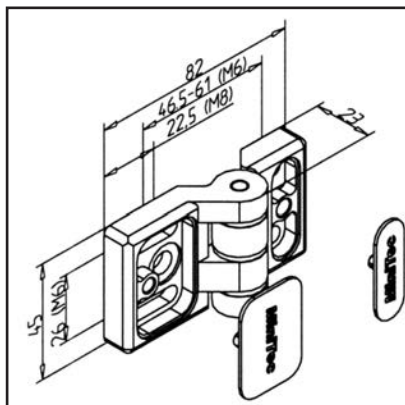

TECHN. DATA / ITEMS SUPPLIED

- Aluminium, Pressure die-casting, powder-coated, grey
- Hinge pin, steel, galvanised
- End caps
- Without fastening kit
- load capacity up to 600 N
- Weight = 0.102 kg/piece

APPLICATIONS

- Suitable for large doors and lids
- Guard units
- Connecting profiles 19, 32 and 45 at any angle

ASSEMBLY

- Fasten hinge with 2 M6 x 18 bolts and 2 square nuts on the profile groove or with screws corresponding to the material thickness directly on the surface elements
- Fasten other hinge half onto profile 45 x 45 with screw M8 x 30 or 2 screws M6 x 18
- For heavy-duty applications use multiple hinges
- Swivel range up to 270°

FOLDING HINGE 45 S

Part no.

21.1098/0

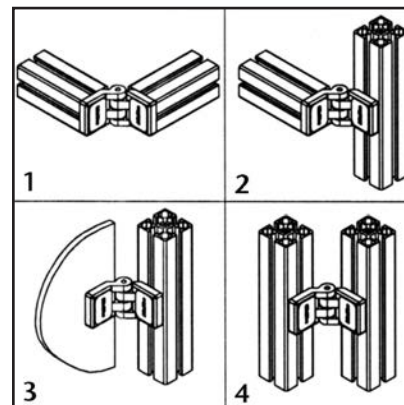
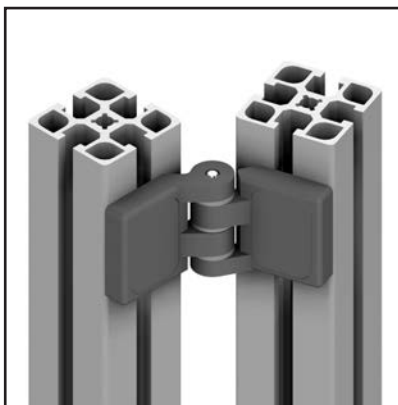
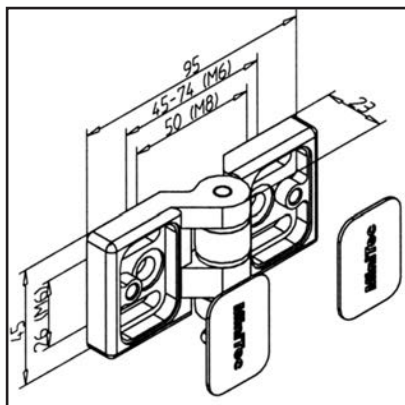

TECHN. DATA / ITEMS SUPPLIED

- Aluminium, Pressure die-casting, powder-coated, grey
- Hinge pin, steel, galvanised
- End caps
- Without fastening kit
- load capacity up to 600 N
- Weight = 0.099 kg/piece

APPLICATIONS

- Suitable for large doors and lids
- Guard units
- Connection of profiles at various angles
- For heavy-duty application use multiple hinges

ASSEMBLY

- 1: 2 screws M8 x 30
- 2: 2 screws M6 x 18, 2 square nut M6, 1 screw M8 x 30
- 3: 2 screws M6 x 18, 2 square nuts M6, for panel element 2 screws M6 according to the material thickness
- 4: 4 screws M6 x 18, 4 square nuts M6
- Swivel range up to 270°

FOLDING HINGE 30 GD

Part no.

21.2532/0

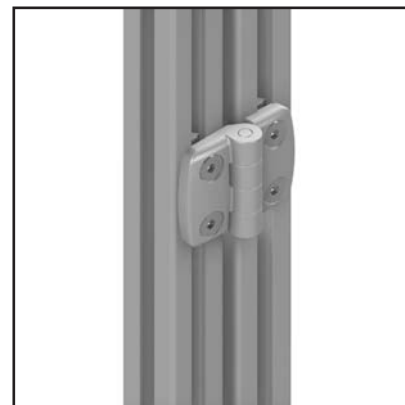
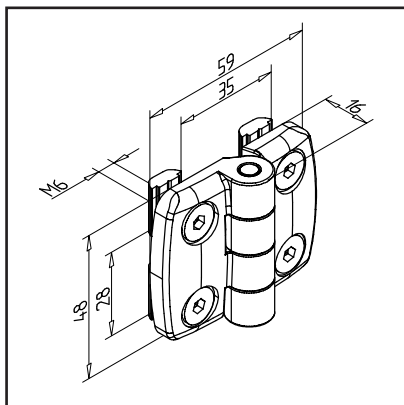
**TECHN. DATA / ITEMS SUPPLIED**

- Aluminium, Pressure die-casting, lacquered, silver
- with stainless steel shaft
- Fastening material steel, galvanized
- Load capacity up to 300 N
- Weight = 0.098 kg/piece

APPLICATIONS

- Suitable for all profiles of series 30
- Doors and lids
- Guard units
- Connection of profiles at various angles

ASSEMBLY

- Screw tight to the profile groove with supplied hardware.

FOLDING HINGE 45 M6

Part no.

21.1175/0

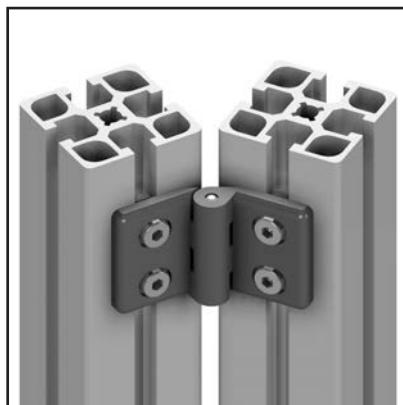
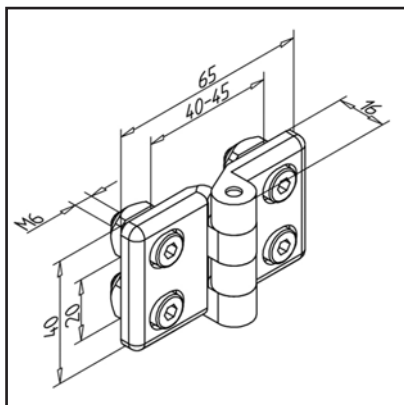
**TECHN. DATA / ITEMS SUPPLIED**

- PA, grey
- With fastening material steel, zinc plated
- load capacity up to 160 N
- Weight = 0.061 kg/piece

APPLICATIONS

- Suitable for light doors and lids
- Guard units
- Connection of profiles at various angles

ASSEMBLY

- Screw tight to the profile groove with supplied hardware.

INTERNAL HINGE AL

Part no.

21.1142/0

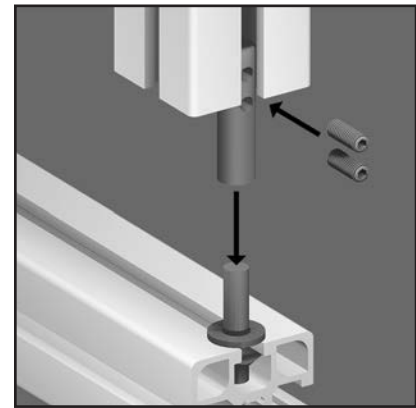
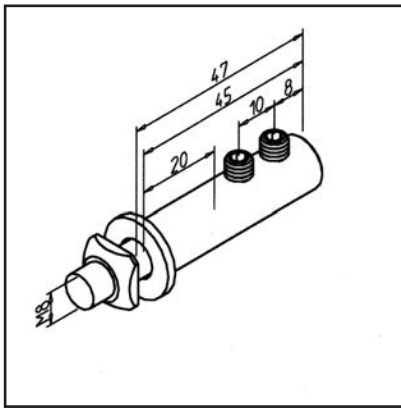

TECHN. DATA / ITEMS SUPPLIED

- Aluminium, anodized E6/EV1
- With fastening material steel, zinc plated
- load capacity up to 250 N
- Weight = 0.032 kg/piece

APPLICATIONS

- Doors
- Lids
- Movable elements
- Retrofitting of doors

ASSEMBLY

- Fix the retaining pins in the frame and place the plastic washer
- Insert hinge into door element
- Position the door element with the grooves over the retaining pins, push the hinges onto the retaining pins and tighten

SWING-OUT HINGE

Part no.

21.1187/0

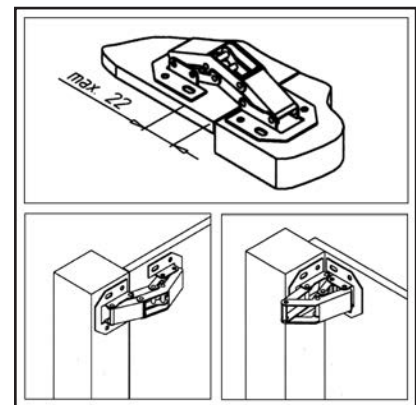
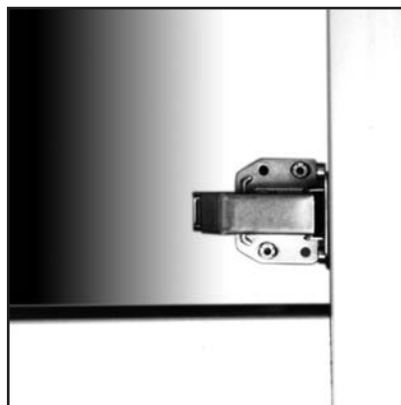
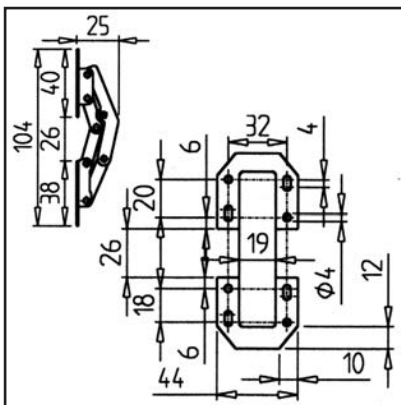

TECHN. DATA / ITEMS SUPPLIED

- Steel, galvanized
- Without fastening kit
- load capacity up to 50 N
- Weight = 0.080 kg/piece

APPLICATIONS

- For lightweight doors
- In windows, measuring devices, safety devices
- Doors latch gap-free either overlying outside or flush inside

ASSEMBLY

- On profile grooves with screws M4 x 16 and square nut M4
- Direct fixation to panel element, screw length must thus be selected according to material strength
- Fastening directly on the profile surface

JOINT 30 S

Part no.

21.2106/0

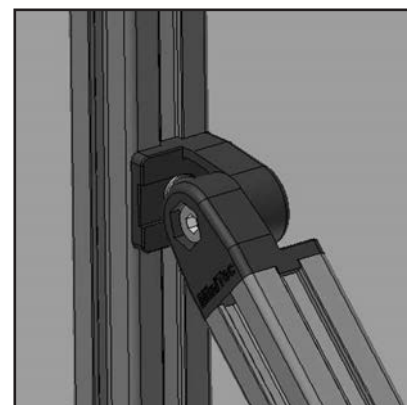
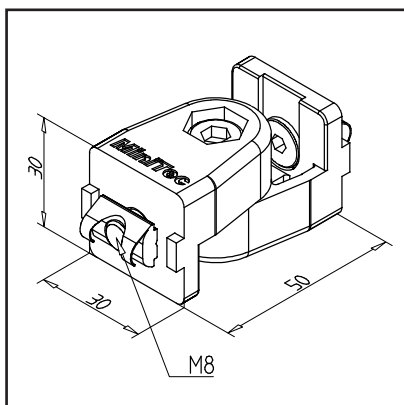
**TECHN. DATA / ITEMS SUPPLIED**

- Aluminium, Pressure die-casting, powder-coated, grey
- With fastening material steel, zinc plated
- Locking device against torsion
- Weight = 0.087 kg/piece

APPLICATIONS

- Connection of profile support under preferred angle
- Retrofitting reinforcement in existing racks
- Alternative: Swivel joint 30 S with slide bushing **part no. 21.2222/0**
- Alternative: Swivel joint 30 S with clamping lever **part no. 21.2225/0**

ASSEMBLY

- Attach the first joint half to the profile strut on the face side
- Fasten the second joint half to the supporting frame
- Screw both parts together on hinge point

JOINT 30 F/S

Part no.

21.2105/0

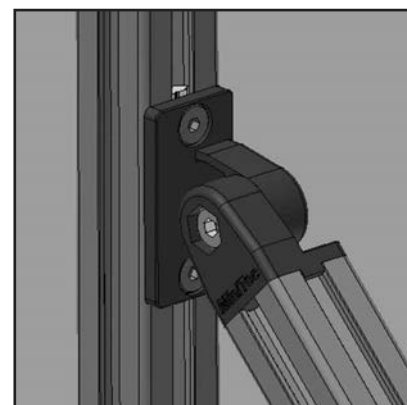
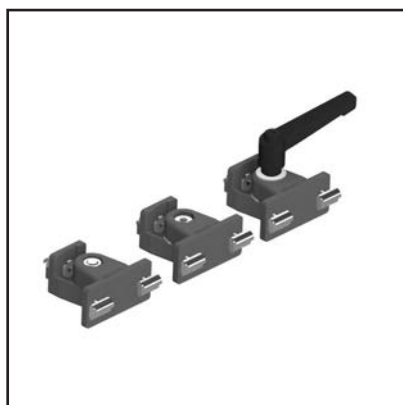
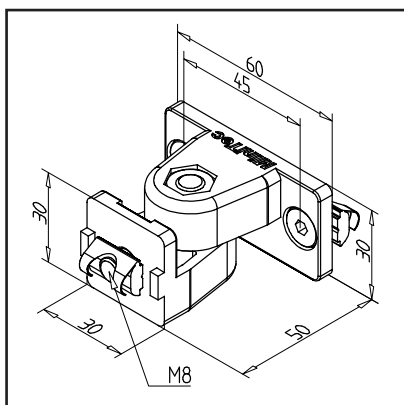
**TECHN. DATA / ITEMS SUPPLIED**

- Aluminium, Pressure die-casting, powder-coated, grey
- With fastening material steel, zinc plated
- Locking device against torsion
- Weight = 0.105 kg/piece

APPLICATIONS

- Connection of profile support under preferred angle
- Retrofitting reinforcement in existing racks
- Alternative: Swivel joint 30 F / S with sliding bushing: **part no. 21.2221/0**
- Alternatively: Swivel joint 30 F/S with clamping lever **part no. 21.2224/0**

ASSEMBLY

- Attach the first joint half to the profile strut on the face side
- Fasten the second joint half to the supporting frame
- Screw both parts together on hinge point

JOINT 30 F

Part no.

21.2111/0

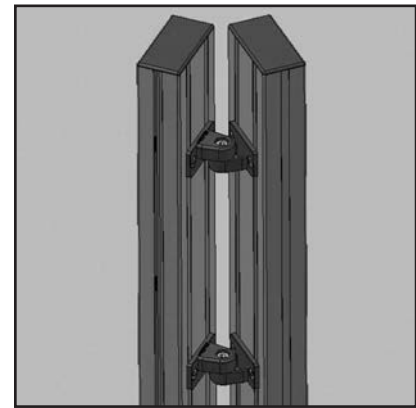
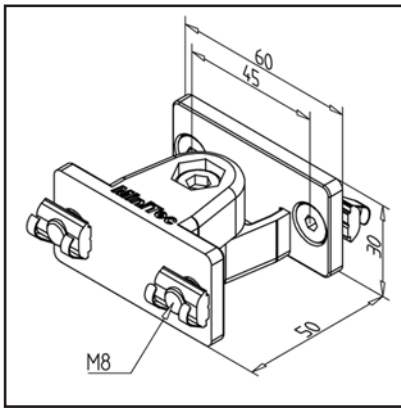

TECHN. DATA / ITEMS SUPPLIED

- Aluminium, Pressure die-casting, powder-coated, grey
- With fastening material steel, zinc plated
- Locking device against torsion
- Weight = 0.126 kg/piece

APPLICATIONS

- Connection of profile support under preferred angle
- Retrofitting reinforcement in existing racks
- Alternative: Swivel joint 30 F with slide bushing **part no. 21.2223/0**
- Alternative: Swivel joint 30 F with clamping lever **part no. 21.2226/0**

ASSEMBLY

- Fasten link to profile face
- Screw both parts together on hinge point

SWIVEL JOINT 45

Part no.

21.2030/0

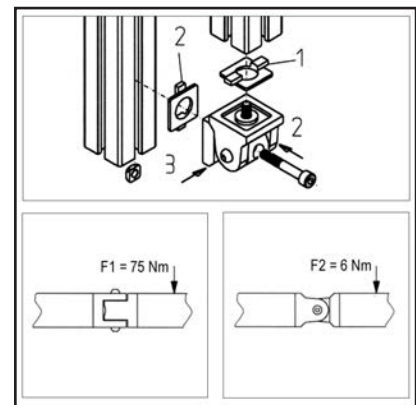
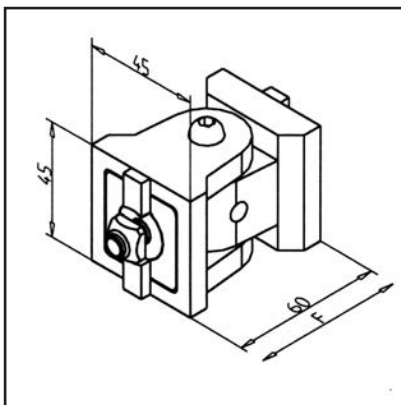

TECHN. DATA / ITEMS SUPPLIED

- Aluminium, Pressure die-casting, powder-coated, grey
- With fastening material steel, zinc plated
- Anti-rotation device AL GD
- Load F_{max} 5000 N
- Use on vertical struts **part no. 21.2030/1**
- Weight = 0.250 kg/piece

APPLICATIONS

- Connection of profiles at various angles
- Bracings
- Reinforcement of frame constructions
- Not to be used as a hinge

ASSEMBLY

- 1: Joint half with pre-mounted screw to desired position fasten
- 2: Screw from scope of supply insert and joint half of 2 fix swivel (to it mobile side 90°)
- 3: Tighten lateral connecting screws

SWIVEL JOINT 45

Part no.

21.2020/0

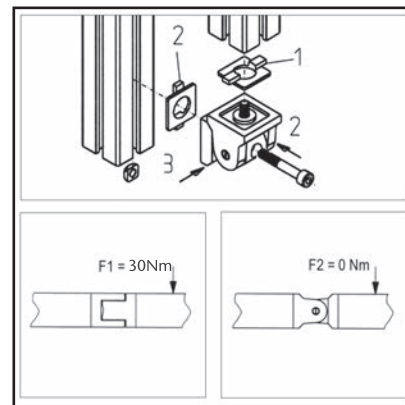
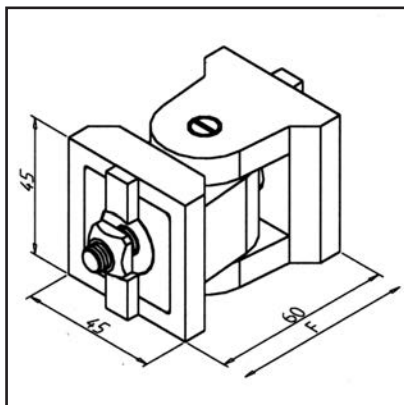
**TECHN. DATA / ITEMS SUPPLIED**

- Aluminium, Pressure die-casting, powder-coated, grey
- With fastening material steel, zinc plated
- With low-friction sliding bearing
- Anti-rotation device AL GD
- Load F_{max} 1500 N
- Use on vertical struts **part no. 21.2020/7**
- Weight = 0.240 kg/piece

APPLICATIONS

- Heavy duty swing doors, storage of moving parts
- Not lockable
- For heavy loads use multiple hinges

ASSEMBLY

- 1: Joint half with pre-mounted screw to desired position fasten
- 2: Put in the screws delivered and fix the joint half 2 (for this, swivel the movable side 90°, do not loosen the bearing pins!)

SWIVEL JOINT 45 WITH CLAMPING LEVER

Part no.

21.2010/0

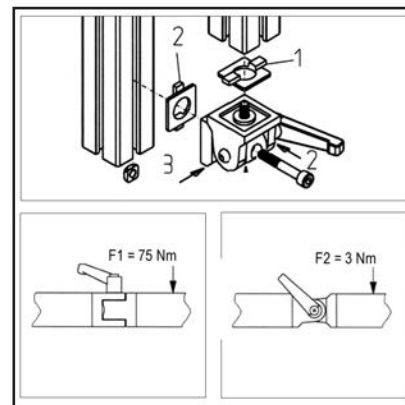
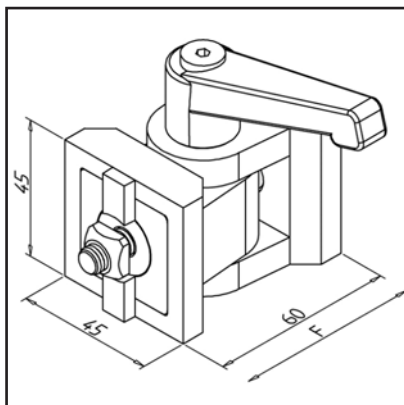
**TECHN. DATA / ITEMS SUPPLIED**

- Aluminium, Pressure die-casting, powder-coated, grey
- With fastening material steel, zinc plated
- With low-friction sliding bearing
- Anti-rotation device AL GD
- Load F_{max} 1500 N
- Use on vertical struts **part no. 21.2010/7**
- Weight = 0.339 kg/piece

APPLICATIONS

- Heavy duty swing doors, storage of moving parts
- Clamping lever for positioning of add-on parts
- Fastening of quick-to-adjust components such as gripping shells, measuring devices
- For heavy loads use multiple hinges

ASSEMBLY

- 1: Joint half with pre-mounted screw to desired position fasten
- 2: Fix with screws included
- 3: Tighten clamping lever

SWIVEL JOINT 45/15

Part no.

21.2315/0

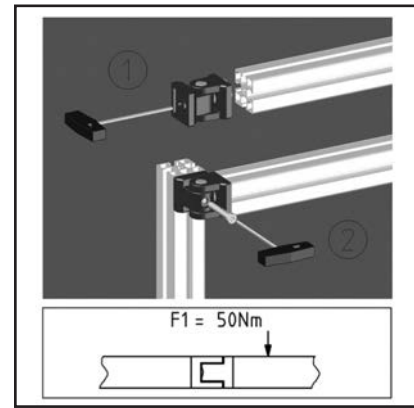
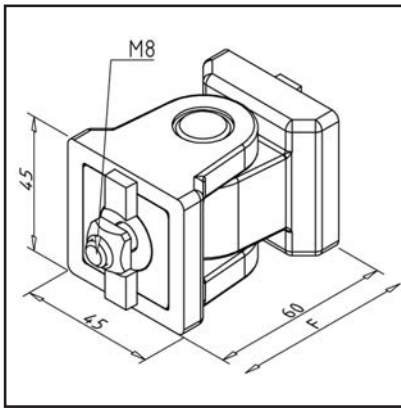

TECHN. DATA / ITEMS SUPPLIED

- Aluminium, Pressure die-casting, powder-coated, grey
- With fastening material steel, zinc plated
- With low-friction sliding bearing
- Anti-rotation device AL GD
- Load F_{max} 2700 N
- Weight = 0.312 kg/piece

APPLICATIONS

- Heavy duty swing doors, storage of moving parts
- Not lockable
- For heavy loads use multiple hinges

ASSEMBLY

- Attach the first joint half to the profile strut on the face side
- Fasten the second joint half to the supporting frame

HEAVY DUTY JOINT 45

Part no.

21.2034/0

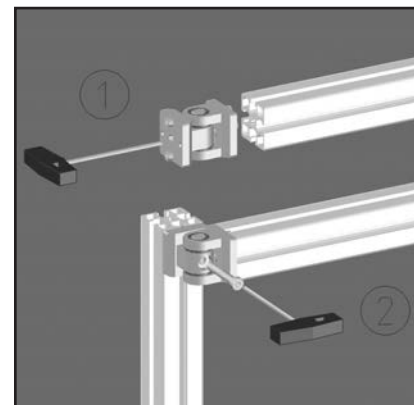
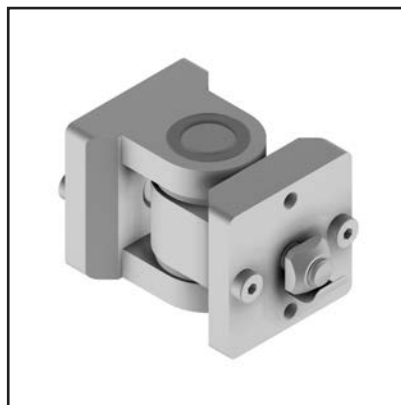
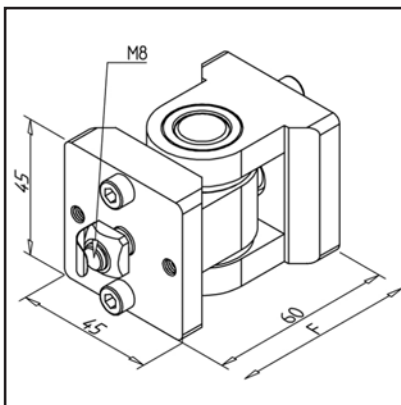

TECHN. DATA / ITEMS SUPPLIED

- Steel, galvanized
- With fastening material steel, zinc plated
- With low-friction sliding bearing
- Locking device against torsion
- Load F_{max} 3500 N
- Load F_1 max 75 Nm
- Weight = 0.680 kg/piece

APPLICATIONS

- Heavy duty swing doors, storage of moving parts
- Not lockable
- For heavy loads use multiple hinges

ASSEMBLY

- Attach the first joint half to the profile strut on the face side
- Fasten the second joint half to the supporting frame

JOINT 45 R

Part no.

21.2041/0

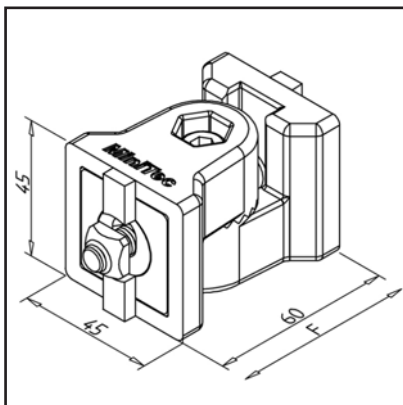
**TECHN. DATA / ITEMS SUPPLIED**

- Aluminium, Pressure die-casting, powder-coated, grey
- With fastening material steel, zinc plated
- Anti-rotation device AL GD
- Load F_{max} 5000 N
- Use on vertical struts **part no. 21.2041/7**
- Weight = 0.263 kg/piece

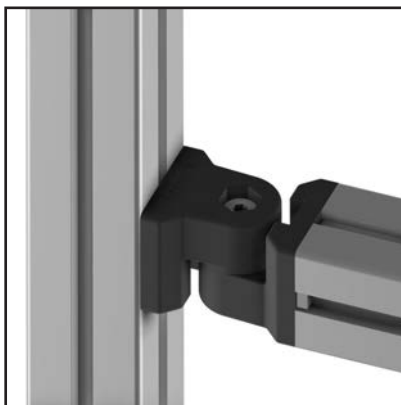
**APPLICATIONS**

- Setting angle 180° in steps of 15°
- Fastening of heavy attachments such as extension arms, gripper cup holders, devices
- Safe adjustment through tooth system

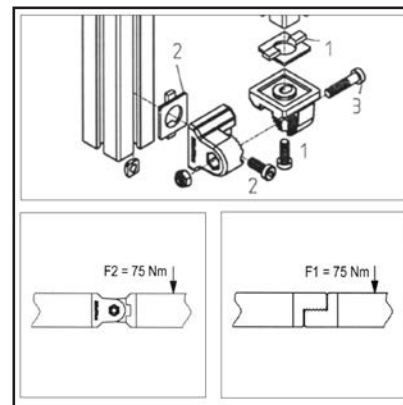
**ASSEMBLY**

- 1: Place locking device and screw first half of the bracket
- 2: Fix second half
- 3: Connect the 2 halves in desired angle and tighten

JOINT 45 R WITH STAR GRIP

Part no.

21.2230/0

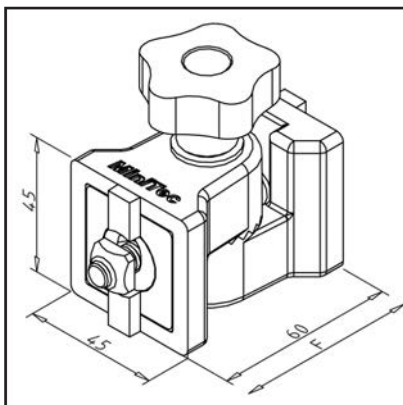
**TECHN. DATA / ITEMS SUPPLIED**

- Aluminium, Pressure die-casting, powder-coated, grey
- With fastening material steel, zinc plated
- Anti-rotation device AL GD
- Load F_{max} 5000 N
- Use on vertical struts **part no. 21.2230/7**
- Weight = 0.279 kg/piece

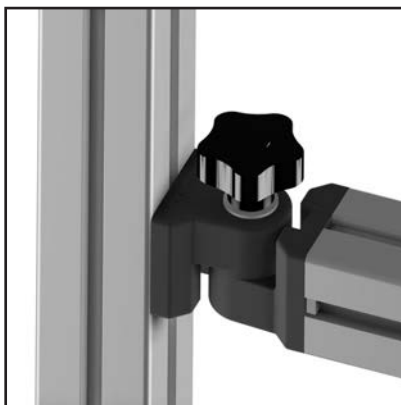
**APPLICATIONS**

- Setting angle 180° in steps of 15°
- Fastening of heavy attachments such as extension arms, gripper cup holders, devices
- Safe adjustment through tooth system

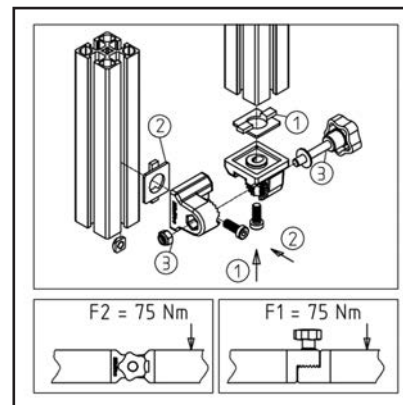
**ASSEMBLY**

- 1: Place locking device and screw first half of the bracket
- 2: Fix second half
- 3: Connect the 2 halves in desired angle and tighten

GAS PRESSURE SPRING 6 / 15

Part no.

24.1126/0

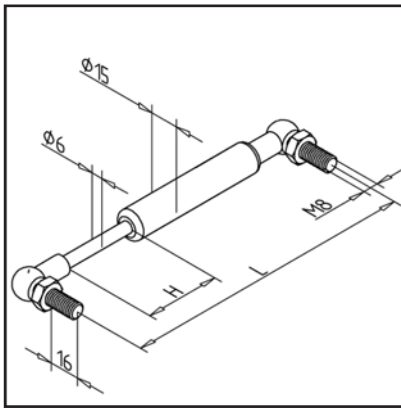

H (mm)	L (mm)
20	115,5
40	155,5
60	194,5
80	235
100	273
120	316
150	375,5

TECHN. DATA / ITEMS SUPPLIED

- Stroke (H) alternatively 20 / 40 / 60 / 80 / 100 / 120 / 150 mm
- Power (F) between 50 and 400 N (increments 50 N)
- **Please indicate desired length of stroke and force**

APPLICATIONS

- For weight compensation with foldable elements
- Suitable for lift and swivel movements

ASSEMBLY

- Fix with thread bolt M8 to profile groove of other components

GAS PRESSURE SPRING 8 / 20

Part no.

24.1127/0

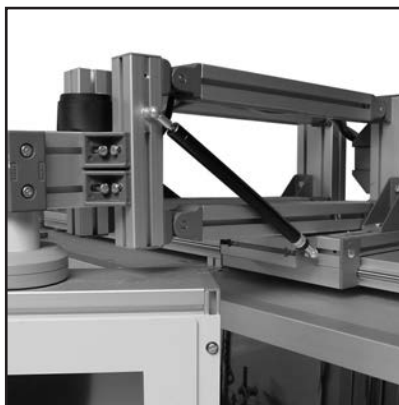
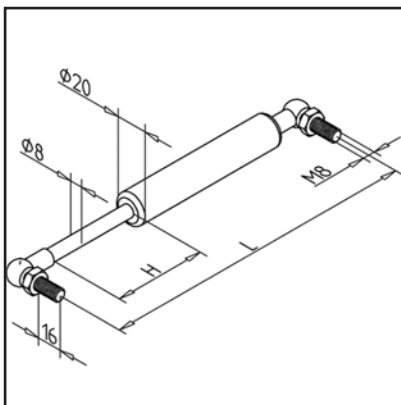

H (mm)	L (mm)
57	206
80	244
100	286
120	326
140	366
160	405
180	446
200	485,5
220	527
250	585,5

TECHN. DATA / ITEMS SUPPLIED

- Stroke (H) alternatively 57 / 80 / 100 / 120 / 140 / 160 / 180 / 200 / 220 / 250 mm
- Power (F) between 80 and 750 N (increments 50 N)
- **Please indicate desired length of stroke and force**

APPLICATIONS

- For weight compensation with foldable elements
- Suitable for lift and swivel movements

ASSEMBLY

- Fix with thread bolt M8 to profile groove of other components

GAS PRESSURE SPRING 10/22

Part no.

24.1128/0

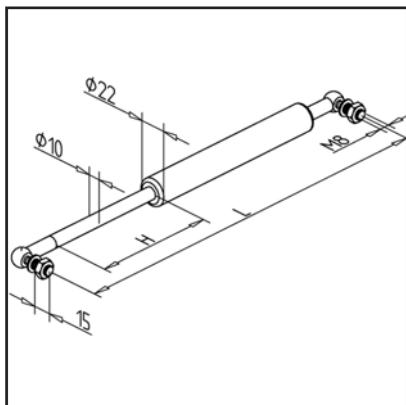

H (mm)	L (mm)
98	286
148	386
198	486
248	586
295	686
345	786
395	886
445	986
495	1086

TECHN. DATA / ITEMS SUPPLIED

- Stroke (H) alternatively 100 / 150 / 200 / 250 / 300 / 350 / 400 mm
- Power (F) between 100 and 1200 N (increments 50 N)
- **Please indicate desired length of stroke and force**

APPLICATIONS

- For weight compensation with foldable elements
- Suitable for lift and swivel movements

ASSEMBLY

- Fix with thread bolt M8 to profile groove of other components

UPRIGHT BEARING

Part no.

28.0158/0

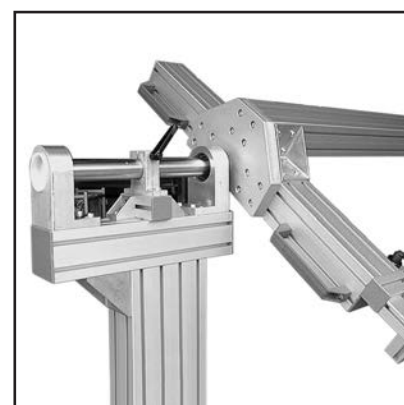
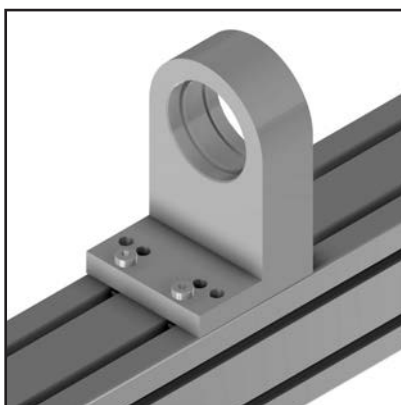
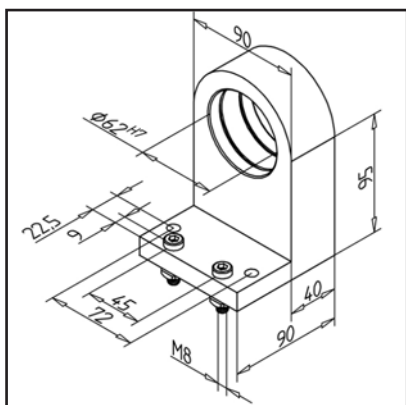
**TECHN. DATA / ITEMS SUPPLIED**

- Aluminium, bright
- With fastening material steel, zinc plated
- Without ball bearing
- Weight = 1.180 kg/piece

APPLICATIONS

- Large swivelling frame
- Guiding of shafts, axles, drums, tires lengthwise and crosswise to the profile

ASSEMBLY

- Mounting hole suitable for radial ball bearings 6206 2RS **part no. 50.0977/1**
- Fasten to the profile with supplied hardware

HANDLE AL

Part no.

21.1138/0

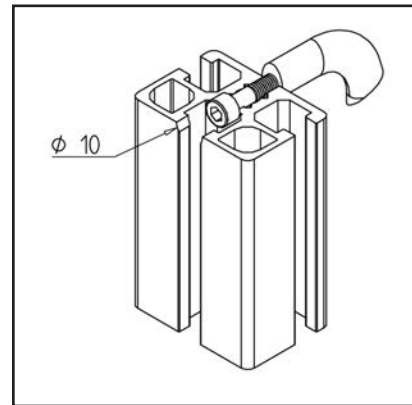
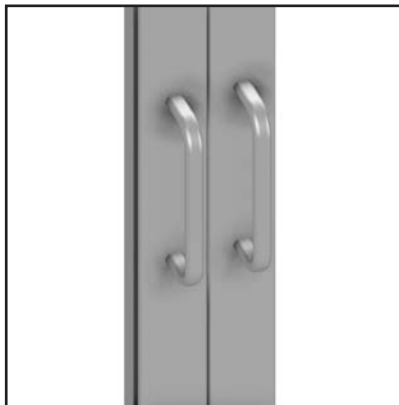
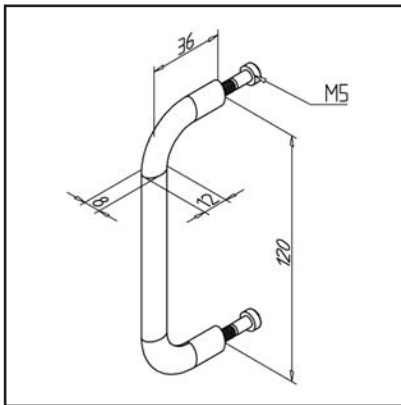

TECHN. DATA / ITEMS SUPPLIED

- Aluminium, anodized E6/EV1
- With fastening material steel, zinc plated
- Weight = 0.050 kg/piece

APPLICATIONS

- display windows, showcases
- Cabinets
- Doors

ASSEMBLY

- Fasten to the profile with supplied hardware
- Provided with stepped bore $\phi 10$ mm x 5.5 mm or through-hole $\phi 5.5$ mm

HANDLE AL ANGLED

Part no.

21.1348/0

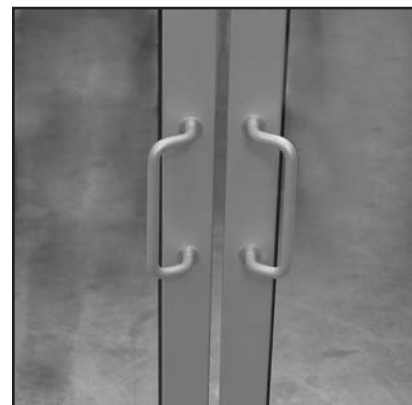
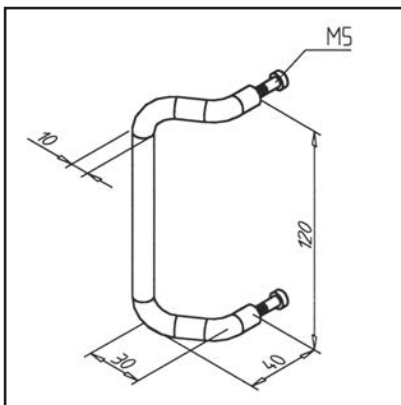

TECHN. DATA / ITEMS SUPPLIED

- Aluminium, anodized E6/EV1
- With fastening material steel, zinc plated
- Weight = 0.065 kg/piece

APPLICATIONS

- display windows, showcases
- Cabinets
- Doors

ASSEMBLY

- Fasten to the profile with supplied hardware
- Provided with stepped bore $\phi 10$ mm x 5.5 mm or through-hole $\phi 5.5$ mm

HANDLE GP

Part no.

21.2317/0

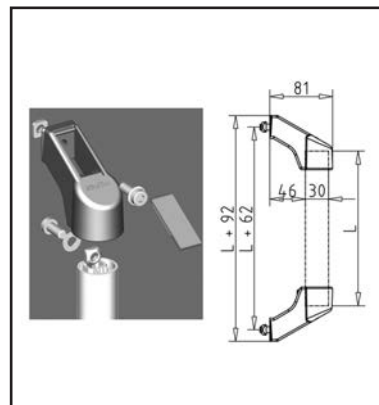
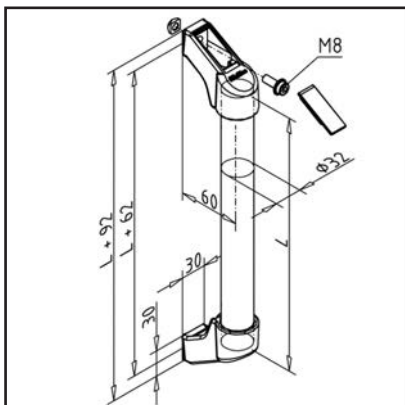

TECHN. DATA / ITEMS SUPPLIED

- Handle profile aluminium, anodized E6/EV1
- Bracket ABS, grey
- Fastening material steel, galvanized
- Standard length (L) 300 mm
- **Other lengths on request**
- **In case of divergent length please specify dimension L**
- Construction set without profile **part no. 21.2317/1**
- Weight = 0.427 kg/piece

APPLICATIONS

- Doors and lids
- Carriage
- Railing

ASSEMBLY

- Attach bracket to handle profile
- Use the included fastening material to attach the profile to the profile grooves

HAND GRIP WITH REACH PROTECTOR

Part no.

21.1048/0

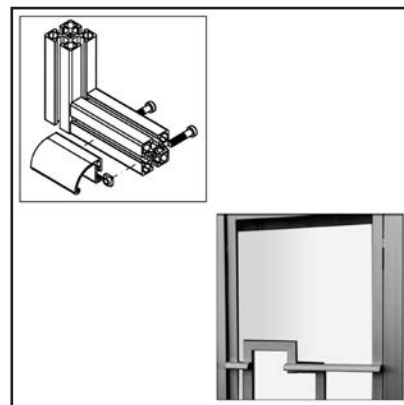
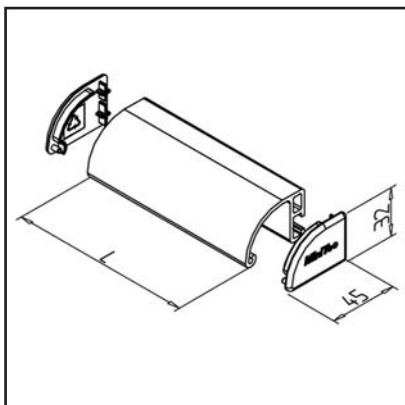

TECHN. DATA / ITEMS SUPPLIED

- Aluminium, anodized E6/EV1
- End caps
- Without fastening kit
- Standard length (L) 120 mm
- **Other lengths on request**
- **In case of divergent length please specify dimension L**
- Weight = 0.110 kg/piece

APPLICATIONS

- Doors
- Lids
- Guard units
- Furniture

ASSEMBLY

- On profile groove with 2 cylinder screws M6 x 16 and square nuts M6, at 15 mm, short hex keys SW 4 required
- Directly on panel element with cylinder screw M6, length according to material thickness
- Installation is also possible from the rear, insert the square nut M6

HANDLE BAR 32

Part no.

21.0962/0

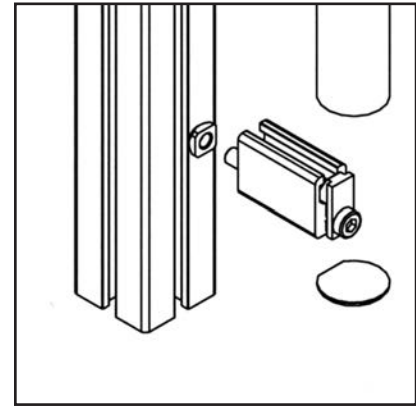
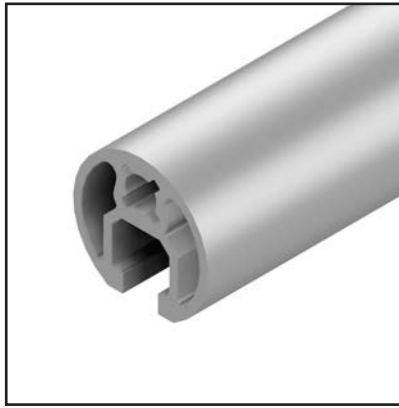
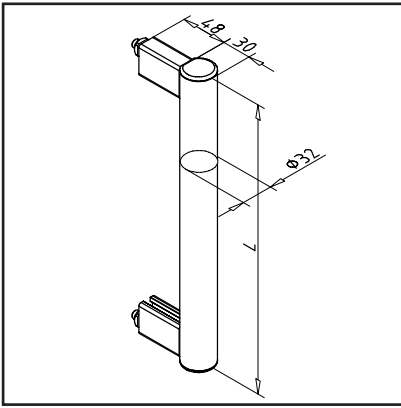

TECHN. DATA / ITEMS SUPPLIED

- Aluminium, anodized E6/EV1
- Ready-to-install kit from MiniTec aluminum profiles
- With fastening material steel, zinc plated
- Standard length (L) 300 mm
- **Other lengths on request**
- **Please specify dimension L**
- Weight = 0.510 kg/piece

APPLICATIONS

- Handle for very large doors, lids, trolleys, removable surface elements

ASSEMBLY

- Enter square nut in existing construction
- Pre-install spacers with a long screw and connector profile
- Insert the handle profile and tighten the profile connector to spacers
- Install caps

HANDLE 90

Part no.

21.1099/1

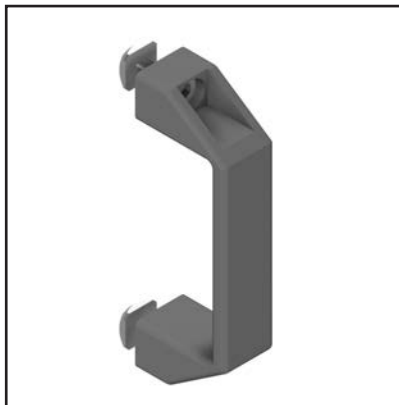
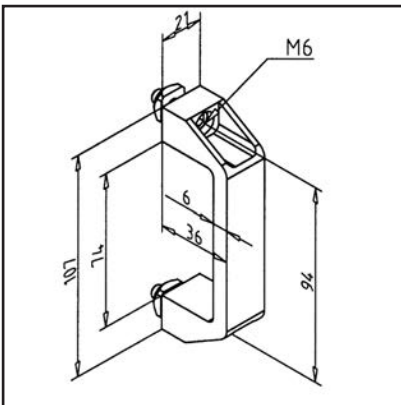

TECHN. DATA / ITEMS SUPPLIED

- PA, grey
- With fastening material steel, zinc plated
- Use on vertical struts **part no. 21.1099/4** (square nut with position-fixing)
- Upon request, available in black, **part no. 21.1099/0**
- Weight = 0.030 kg/piece

APPLICATIONS

- Doors
- Lids
- Guard units

ASSEMBLY

- Fasten to profile groove with supplied hardware.
- Directly on panel element with cylinder screw M6, length according to material thickness

HANDLE 120

Part no. 21.1092/1

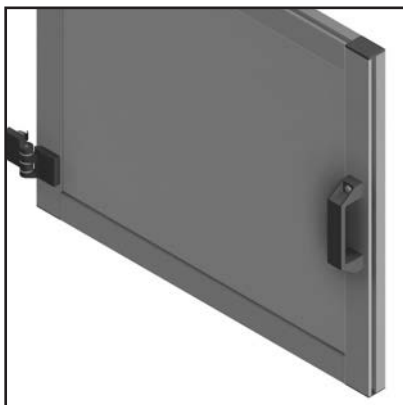
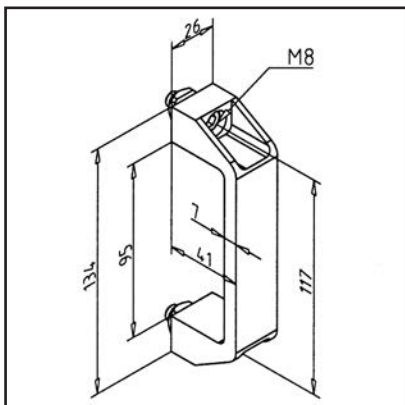

TECHN. DATA / ITEMS SUPPLIED

- PA, grey
- With fastening material steel, zinc plated
- Use on vertical struts **part no. 21.1092/4** (square nut with position-fixing)
- Upon request, available in black, **part no. 21.1092/0**
- ESD-compatible, also available in black **part no. 32.1007/0**, upon request
- Weight = 0.070 kg/piece

APPLICATIONS

- Doors
- Lids
- Guard units

ASSEMBLY

- Fasten to profile groove with supplied hardware.
- Directly on surface element with cylinder head screw M8

HANDLE 135

Part no. 21.2530/1

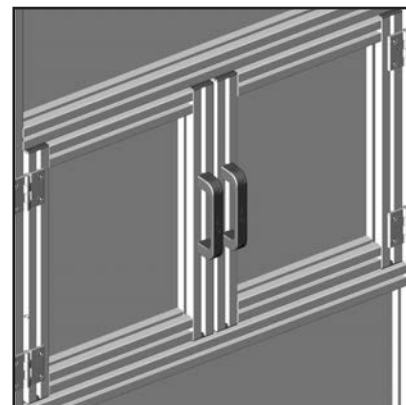
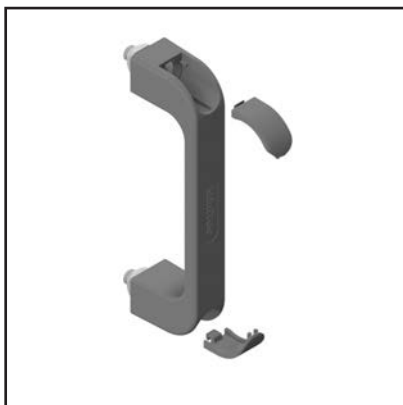
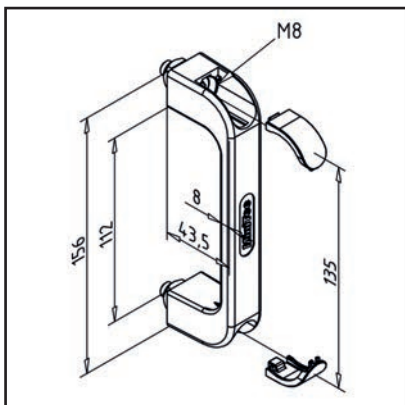

TECHN. DATA / ITEMS SUPPLIED

- PA, grey
- With fastening material steel, zinc plated
- Use on vertical struts **part no. 21.2530/7**
- Weight = 0.080 kg/piece

APPLICATIONS

- Doors
- Lids
- Guard units

ASSEMBLY

- Fasten to profile groove with supplied hardware.
- Directly on surface element with cylinder head screw M8

HANDLE 180

Part no.

21.1094/1

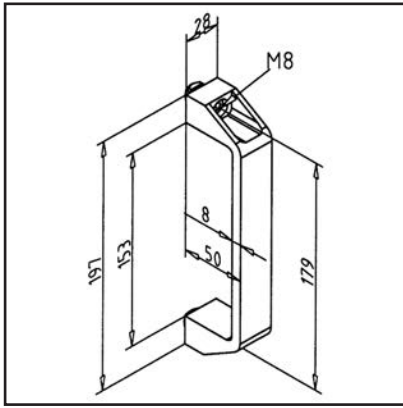

TECHN. DATA / ITEMS SUPPLIED

- PA, grey
- With fastening material steel, zinc plated
- Use on vertical struts **part no. 21.1094/4** (square nut with position-fixing)
- Upon request, available in black, **part no. 21.1094/0**
- Weight = 0.100 kg/piece

APPLICATIONS

- Doors
- Lids
- Guard units

ASSEMBLY

- Fasten to profile groove with supplied hardware.
- Directly on surface element with cylinder head screw M8

LOCK CYLINDER

Part no.

21.1752/0

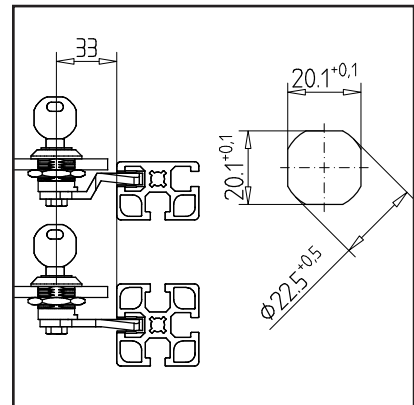
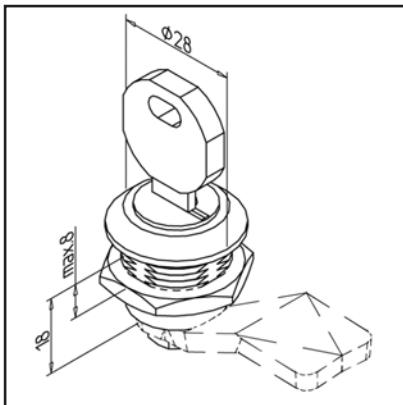

TECHN. DATA / ITEMS SUPPLIED

- Zinc, Pressure die-casting, chromed
- With fastening nut steel, galvanized
- 2 keys
- Without locks
- Weight = 0.100 kg/piece

APPLICATIONS

- Light doors from surface elements up to 8 mm thickness

ASSEMBLY

- Bore Ø 22 mm in panel element
- As an alternative to torsion-protected mounting Milling according to sketch
- Select the locking tongue suitable for the application or profiles used.
- To prevent damage to the profile grooves, additional edging and cover profiles can be used.

DEADBOLT 32 WITH ALLEN WRENCH SW 10

Part no.

21.1087/8

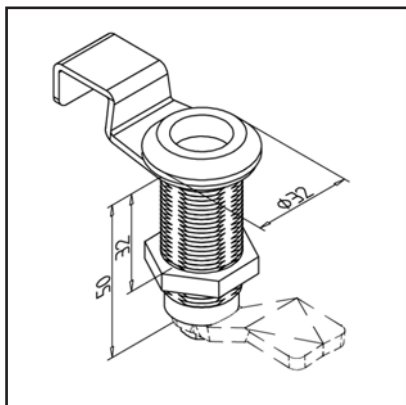
**TECHN. DATA / ITEMS SUPPLIED**

- Zinc, Pressure die-casting, black
- For Allen wrench SW 10
- With fastening nut steel, galvanized
- With opening bracket, steel, black
- Without locks
- Weight = 0.102 kg/piece

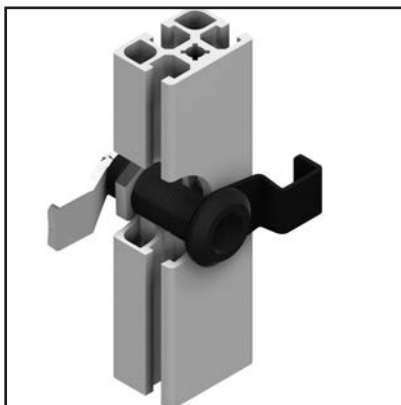
**APPLICATIONS**

- For profiles 32
- Locking of doors and lids in guard units

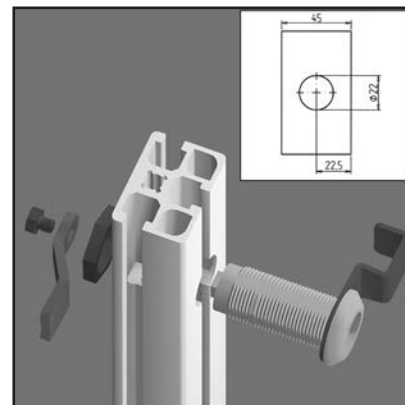
**ASSEMBLY**

- Drill hole \varnothing 22 mm in the centre of the profile, recommended: anti-twist protection F **part no.. 21.0941/0.**
- To ensure the torsion protection, a pocket with SW 20.1 mm can alternatively be milled.
- Tighten using front handle from the back side with the fastening nut

DEADBOLT 32 WITH SQUARE KEY SW 7

Part no.

21.1087/6

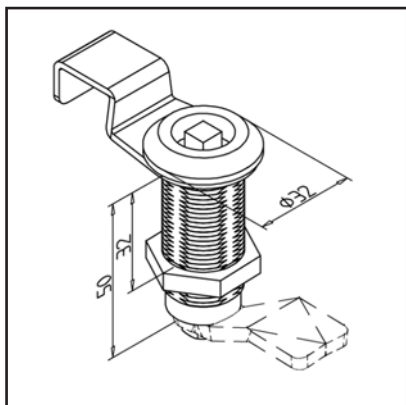
**TECHN. DATA / ITEMS SUPPLIED**

- Zinc, Pressure die-casting, black
- With square box wrench
- With fastening nut steel, galvanized
- With opening bracket, steel, black
- Without locks
- Weight = 0.179 kg/piece

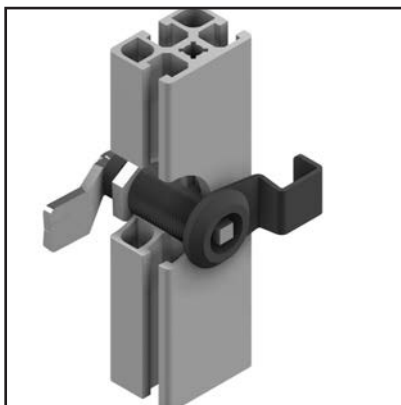
**APPLICATIONS**

- For profiles 32
- Locking of doors and lids in guard units

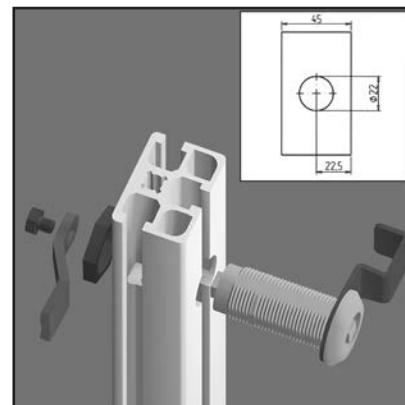
**ASSEMBLY**

- Drill hole \varnothing 22 mm in the centre of the profile, recommended: anti-twist protection F **part no.. 21.0941/0.**
- To ensure the torsion protection, a pocket with SW 20.1 mm can alternatively be milled.
- Tighten using front handle from the back side with the fastening nut

DEADBOLT 45 WITH ALLEN WRENCH SW 10

Part no.

21.1087/9

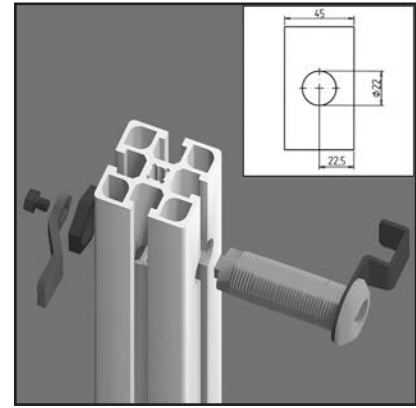
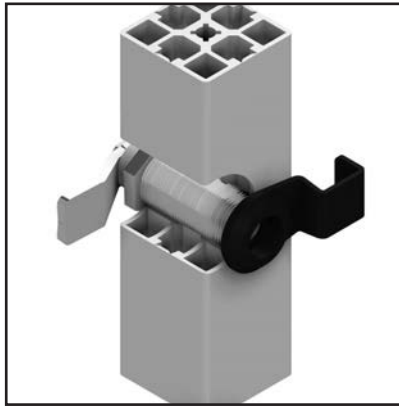
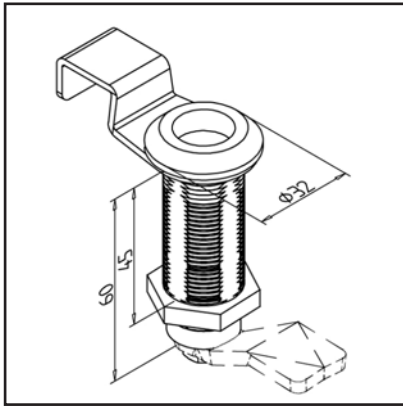

TECHN. DATA / ITEMS SUPPLIED

- Zinc, Pressure die-casting, black
- For Allen wrench SW 10
- With fastening nut steel, galvanized
- With opening bracket, steel, black
- Without locks
- Weight = 0.111 kg/piece

APPLICATIONS

- For profiles 45
- Locking of doors and lids in guard units

ASSEMBLY

- Drill hole \varnothing 22 mm in the centre of the profile, recommended: anti-twist protection F **part no.. 21.0941/0.**
- To ensure the torsion protection, a pocket with SW 20.1 mm can alternatively be milled.
- Tighten using front handle from the back side with the fastening nut

DEADBOLT 45 WITH SQUARE KEY SW 7

Part no.

21.1087/7

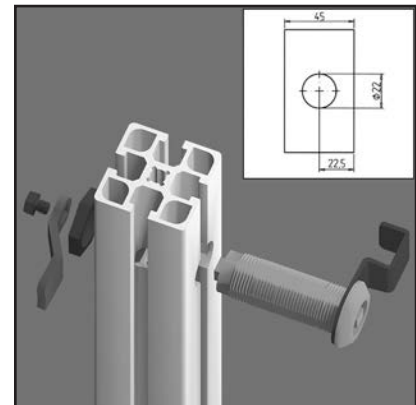
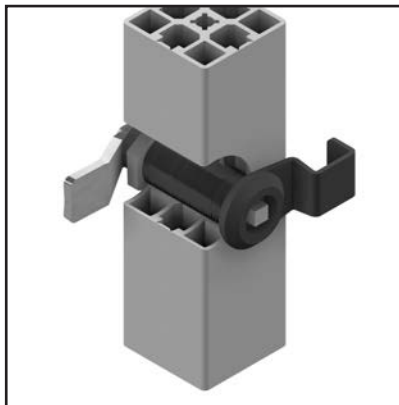
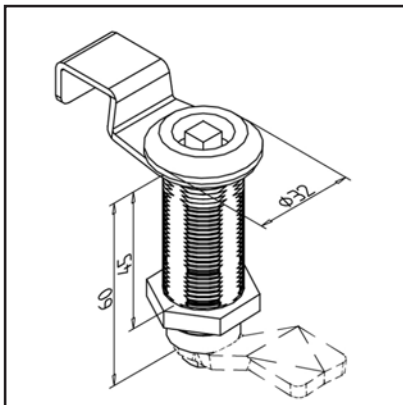

TECHN. DATA / ITEMS SUPPLIED

- Zinc, Pressure die-casting, black
- With square box wrench
- With fastening nut steel, galvanized
- With opening bracket, steel, black
- Without locks
- Weight = 0.197 kg/piece

APPLICATIONS

- For profiles 45
- Locking of doors and lids in guard units

ASSEMBLY

- Drill hole \varnothing 22 mm in the centre of the profile, recommended: anti-twist protection F **part no.. 21.0941/0.**
- To ensure the torsion protection, a pocket with SW 20.1 mm can alternatively be milled.
- Tighten using front handle from the back side with the fastening nut

RATCHET HANDLE 8

Part no.

21.2305/0

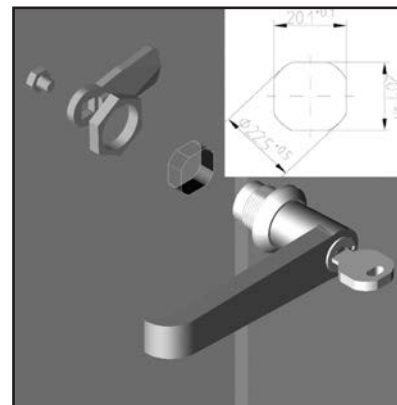
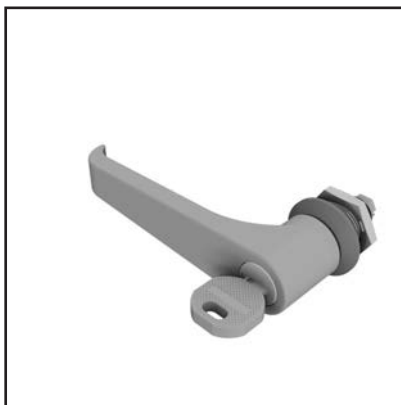
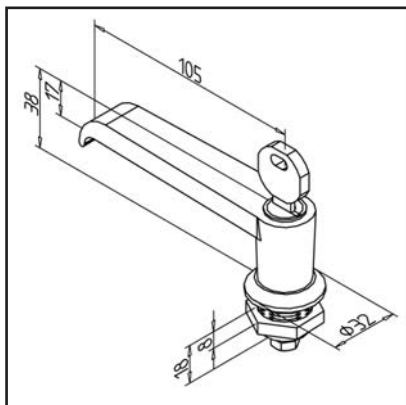
**TECHN. DATA / ITEMS SUPPLIED**

- Handle PA, grey
- Housing DG Zn GD Zn, grey
- With fastening nut steel, galvanized
- Without locks
- Weight = 0.145 kg/piece

APPLICATIONS

- Locking of doors and lids in guard units
- For surface elements up to 8 mm thickness

ASSEMBLY

- Drill the bore according to the sketch
- Using a ratchet handle, tighten the fastening nut from behind

RATCHET HANDLE 32 WITHOUT PROFILE CYLINDER LOCK

Part no.

21.1087/4

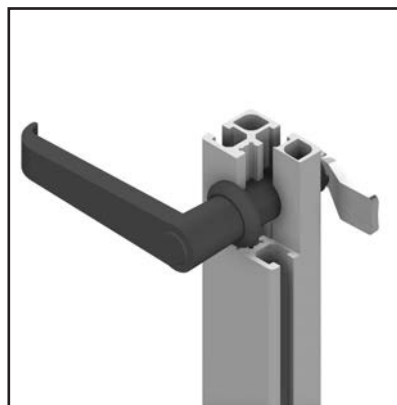
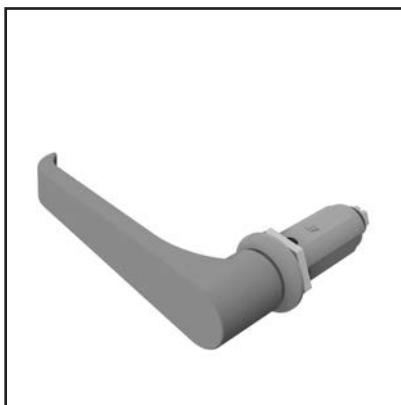
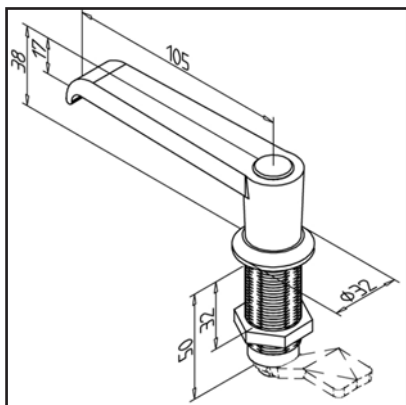
**TECHN. DATA / ITEMS SUPPLIED**

- Handle PA, grey
- Housing DG Zn GD Zn, grey
- With fastening nut steel, galvanized
- Without locks
- On request also available in black, **part no. 21.1087/2**
- Weight = 0.172 kg/piece

APPLICATIONS

- For profiles 32
- Locking of doors and lids in guard units

ASSEMBLY

- Drill hole $\varnothing 22$ mm in the centre of the profile, recommended: anti-twist protection F **part no. 21.0941/0**.
- To ensure the torsion protection, a pocket with SW 20.1 mm can alternatively be milled.
- Using a ratchet handle, tighten the fastening nut from behind

RATCHET HANDLE 32 WITH LOCK

Part no. 21.1091/4

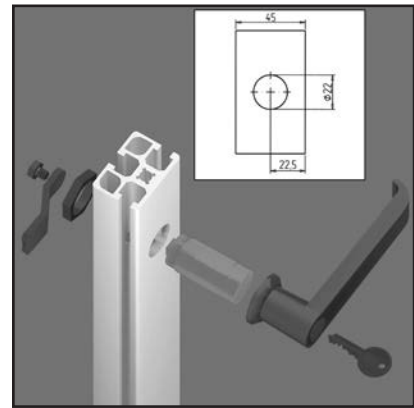
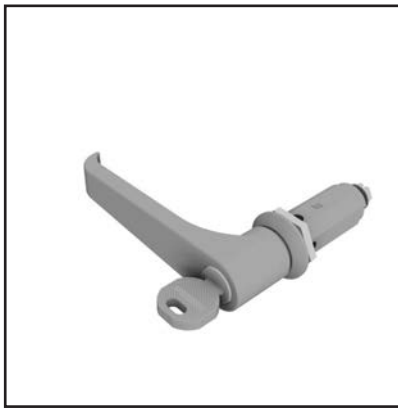
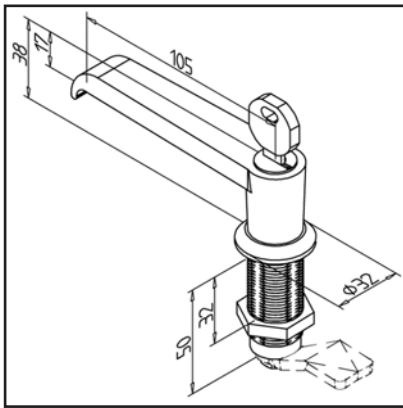

TECHN. DATA / ITEMS SUPPLIED

- Handle PA, grey
- Housing DG Zn GD Zn, grey
- With fastening nut steel, galvanized
- Without locks
- Upon request, available in black, **part no. 21.1091/2**
- Weight = 0.211 kg/piece

APPLICATIONS

- For profiles 32
- Locking of doors and lids in guard units

ASSEMBLY

- Drill hole \varnothing 22 mm in the centre of the profile, recommended: anti-twist protection F **part no. 21.0941/0**.
- To ensure the torsion protection, a pocket with SW 20.1 mm can alternatively be milled.
- Using a ratchet handle, tighten the fastening nut from behind

RATCHET HANDLE 45 WITHOUT LOCK

Part no. 21.1087/3

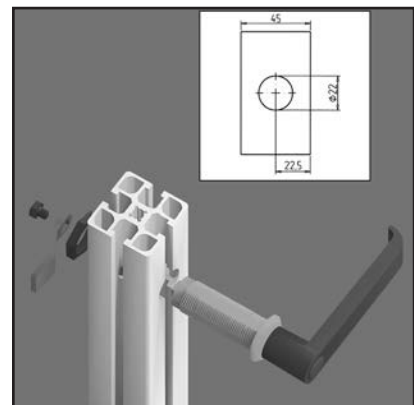
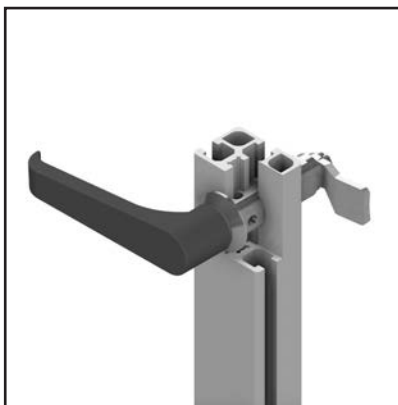
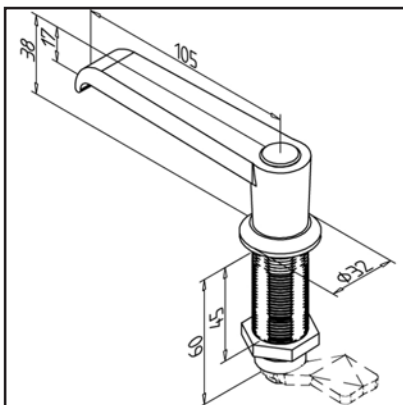

TECHN. DATA / ITEMS SUPPLIED

- Handle PA, grey
- Housing DG Zn GD Zn, grey
- With fastening nut steel, galvanized
- Without locks
- Upon request, available in black, **part no. 21.1087/1**
- Weight = 0.194 kg/piece

APPLICATIONS

- For profiles 45
- Locking of doors and lids in guard units

ASSEMBLY

- Drill hole \varnothing 22 mm in the centre of the profile, recommended: anti-twist protection F **part no. 21.0941/0**.
- To ensure the torsion protection, a pocket with SW 20.1 mm can alternatively be milled.
- Using a ratchet handle, tighten the fastening nut from behind

RATCHET HANDLE 45 WITH LOCK

Part no.

21.1091/3

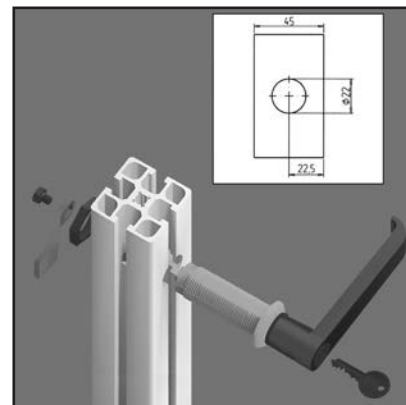
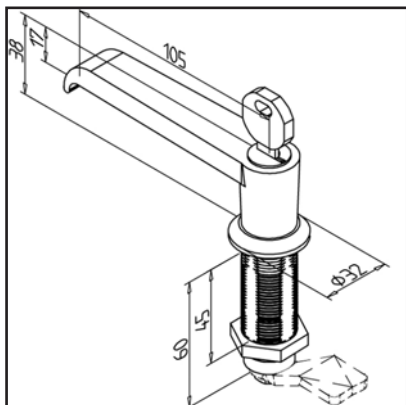
**TECHN. DATA / ITEMS SUPPLIED**

- Handle PA, grey
- Housing DG Zn GD Zn, grey
- With fastening nut steel, galvanized
- Without locks
- Upon request, available in black, **part no. 21.1091/1**
- Weight = 0.230 kg/piece

APPLICATIONS

- For profiles 45
- Locking of doors and lids in guard units

ASSEMBLY

- Drill hole \varnothing 22 mm in the centre of the profile, recommended: anti-twist protection F **part no.. 21.0941/0.**
- To ensure the torsion protection, a pocket with SW 20.1 mm can alternatively be milled.
- Using a ratchet handle, tighten the fastening nut from behind

TOGGLE HANDLE 19

Part no.

21.1015/2

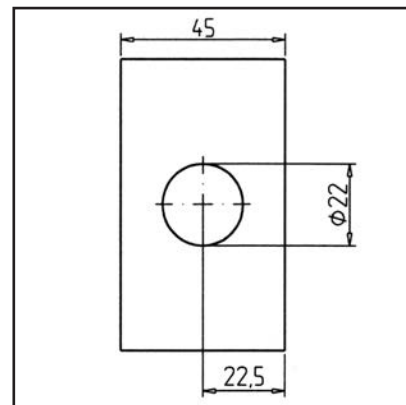
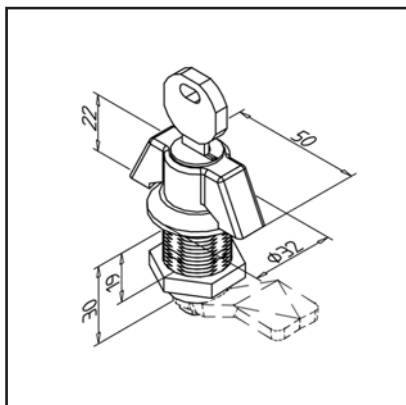
**TECHN. DATA / ITEMS SUPPLIED**

- Zinc, Pressure die-casting, chromed
- With fastening nut steel, galvanized
- Without locks
- Weight = 0.150 kg/piece

APPLICATIONS

- For profiles 19
- Locking of doors and lids in guard units

ASSEMBLY

- Drill hole \varnothing 22 mm in the centre of the profile, recommended: anti-twist protection F **part no.. 21.0941/0.**
- To ensure the torsion protection, a pocket with SW 20.1 mm can alternatively be milled.
- Using a ratchet handle, tighten the fastening nut from behind

TOGGLE HANDLE 32

Part no.

21.1015/0

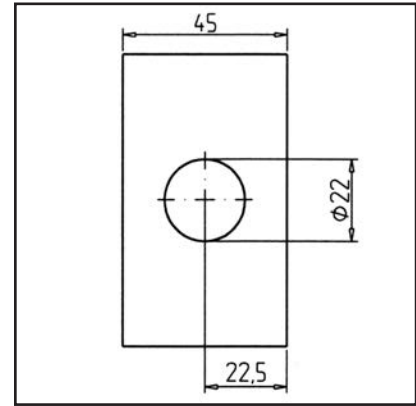
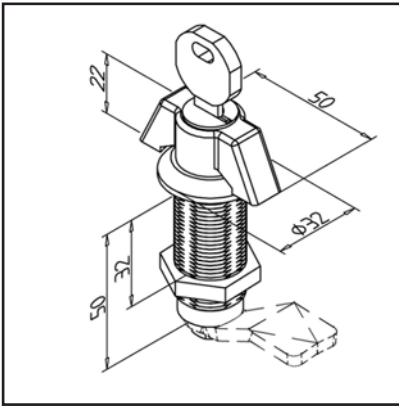

TECHN. DATA / ITEMS SUPPLIED

- Zinc, Pressure die-casting, chromed
- With fastening nut steel, galvanized
- Without locks
- Weight = 0.190 kg/piece

APPLICATIONS

- For profiles 32
- Locking of doors and lids in guard units

ASSEMBLY

- Drill hole \varnothing 22 mm in the centre of the profile, recommended: anti-twist protection F **part no.. 21.0941/0.**
- To ensure the torsion protection, a pocket with SW 20.1 mm can alternatively be milled.
- Using a ratchet handle, tighten the fastening nut from behind

TOGGLE HANDLE 45

Part no.

21.1015/1

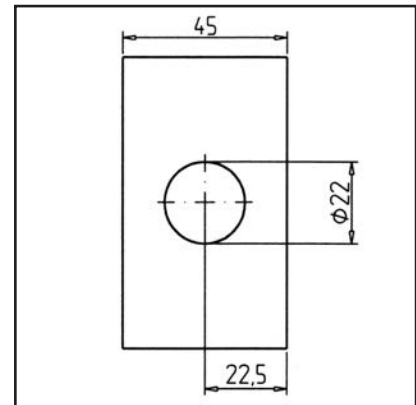
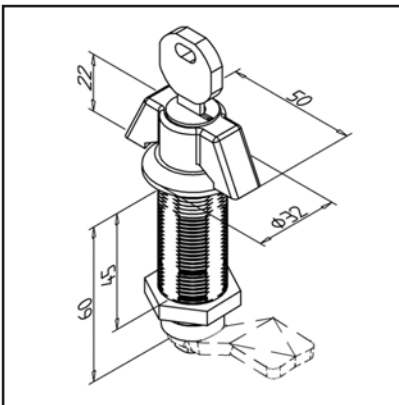

TECHN. DATA / ITEMS SUPPLIED

- Zinc, Pressure die-casting, chromed
- With fastening nut steel, galvanized
- Without locks
- Weight = 0.210 kg/piece

APPLICATIONS

- For profiles 45
- Locking of doors and lids in guard units

ASSEMBLY

- Drill hole \varnothing 22 mm in the centre of the profile, recommended: anti-twist protection F **part no.. 21.0941/0.**
- To ensure the torsion protection, a pocket with SW 20.1 mm can alternatively be milled.
- Using a ratchet handle, tighten the fastening nut from behind

TWIST PROTECTION F

Part no.

21.0941/0

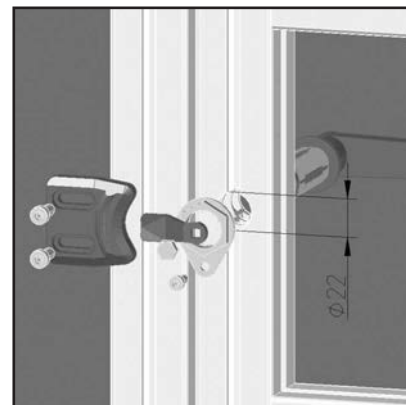
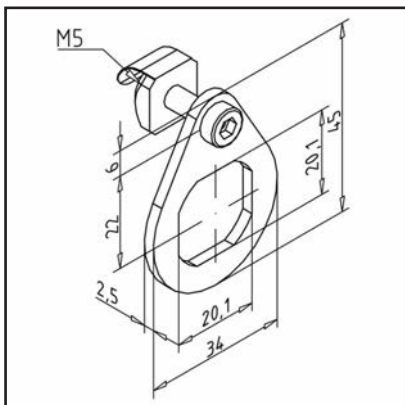

TECHN. DATA / ITEMS SUPPLIED

- Stainless steel
- With fastening material steel, zinc plated
- Weight = 0.021 kg/piece

APPLICATIONS

- Secure sash locks, latch handles and toggle handles against self-acting loosening or overturning
- Specifically intended for use with door stop S, **part no. 21.1767/0**

ASSEMBLY

- Install front handle, T-handle or L-handle as usual, tighten hexagon nut
- Swivel in square nut and mount twist stop
- Install the latch

DOOR CATCH S

Part no.

21.1767/0

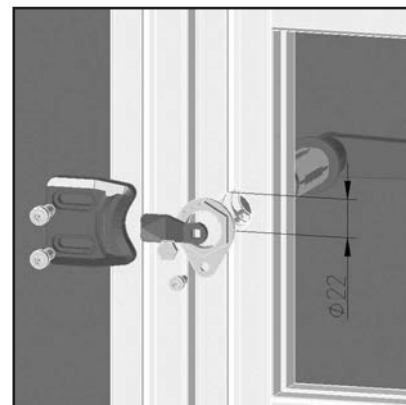
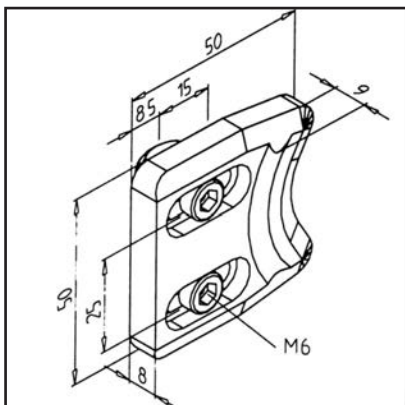

TECHN. DATA / ITEMS SUPPLIED

- Zinc, Pressure die-casting, black
- With fastening material steel, zinc plated
- Weight = 0.077 kg/piece

APPLICATIONS

- Stop for doors and hatches
- Specifically suitable in connection with handle, T-handle and bolt lock
- Also door catch

ASSEMBLY

- Fasten to the posts with supplied hardware

DOOR CATCH 19

Part no.

21.1755/0

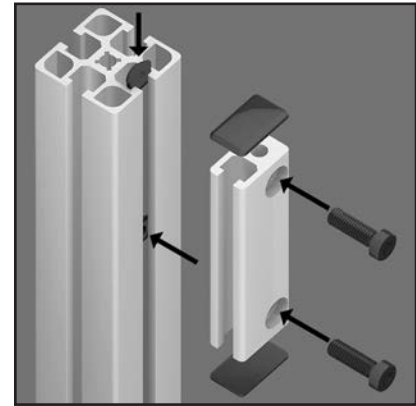
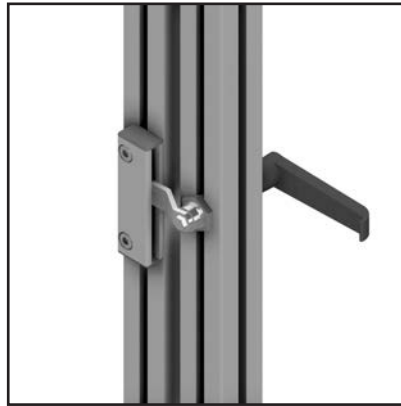
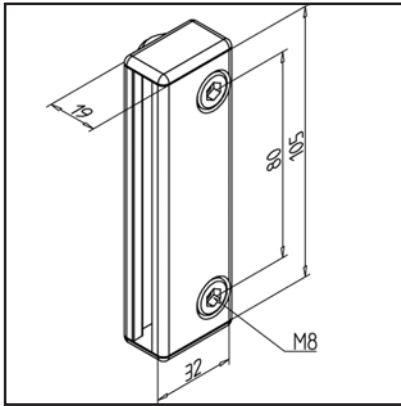

TECHN. DATA / ITEMS SUPPLIED

- Aluminium, anodized E6/EV1
- From profile 19 x 32
- End caps
- With fastening nut steel, galvanized
- Weight = 0.040 kg/piece

APPLICATIONS

- Locking of doors and lids in connection with handles or bolt locks

ASSEMBLY

- Fasten to profile groove with supplied hardware.

LOCKS

FITTING PRINCIPLES & SELECTION OF LOCKS

FITTING PRINCIPLES

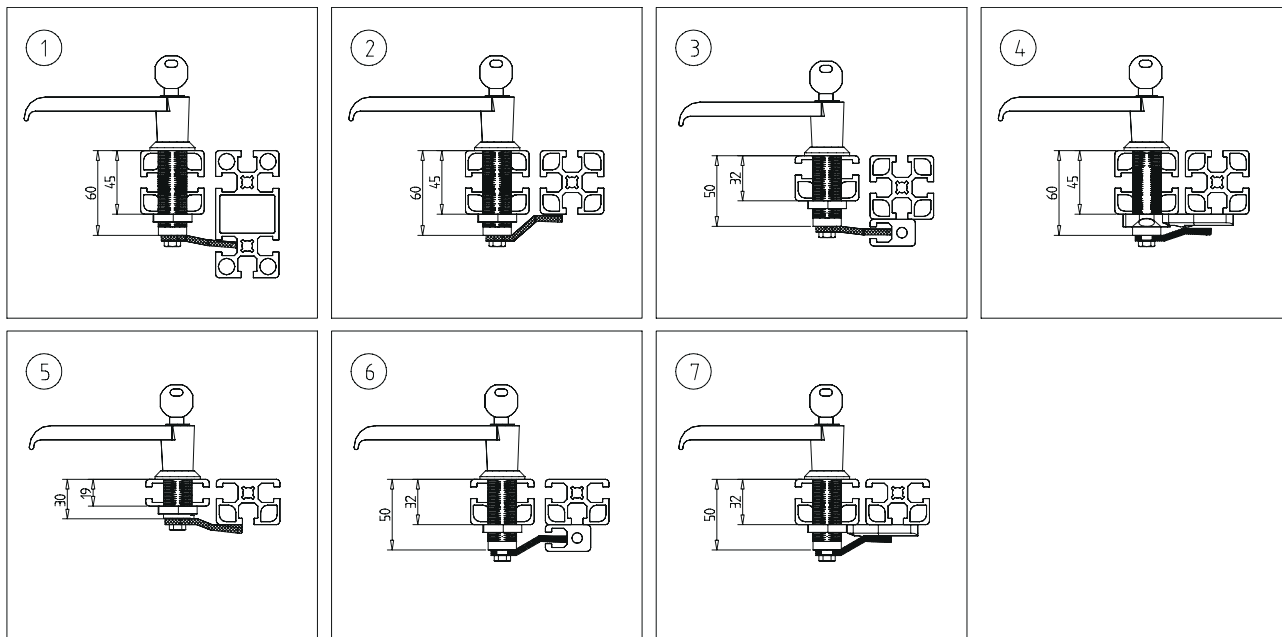

SELECTION OF LOCKS

Door profile	Door profile 45 x 45 mm	Door profile 32 x 45 mm	Door profile 19 x 45 mm	Surface element 4-8 mm
	Handle, T-Handle or Bolt lock 45	Handle, T-Handle or Bolt lock 32	Handle, T-Handle or Bolt lock 19	cylinder lock
part no. of locks				
1 - 90 x 45	21.1093/1	21.1093/0	-	21.1093/2
2 - 45 x 45	21.1093/5	21.1093/3	21.1093/4 o. /0	21.1093/2
3 - with catch 19	21.1093/4	21.1093/2	-	-
4 - with door catch S	21.1093/3	21.1093/1	-	-
5 - 32 x 45	-	-	21.1093/1	-
6 - with catch 19	-	21.1093/5	-	21.1093/0
7 - with door catch S	-	21.1093/4	21.1093/0	-

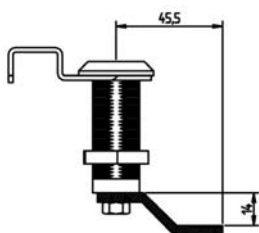

Part no. 21.1093/0

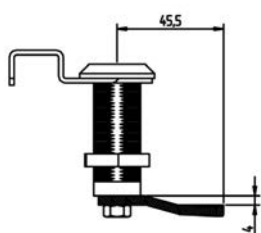

Part no. 21.1093/1

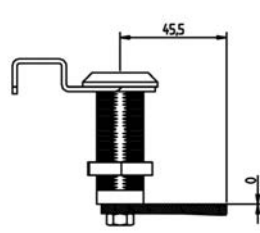

Part no. 21.1093/2

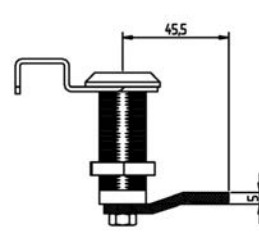

Part no. 21.1093/3

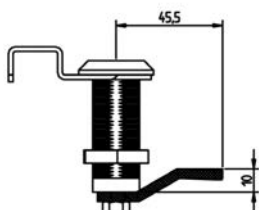

Part no. 21.1093/4

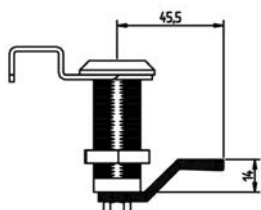

Part no. 21.1093/5

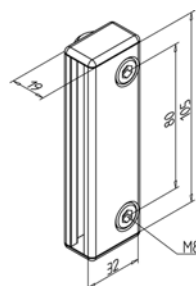

Part no. 21.1755/0

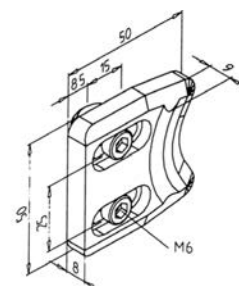

Part no. 21.1767/0

ROD LOCK

ONE OR TWO-SIDED LOCKING

Items Supplied

- Bolt lock, steel, black with square key
- Guiding element, steel, galvanized
- Latch with rollers (l = 1100 mm), steel, galvanized
- Rod guide, plastic, black with injected nut M6

Optional

- Handle with or without lock

Application

- For locking doors at upper or lower beam
- Use 2 rods for 2-sided locking
- Order bolt lock, handle without lock or handle with cylinder lock
- Especially suited for control boxes or double-sided doors

Available versions

PROFILE	Bolt lock		Handle without lock		Handle with cylinder lock	
	1 rod	2 rods	1 rod	2 rods	1 rod	2 rods
32 x 45	21.1798/0	21.1798/2	21.1798/3	21.1798/4	21.1798/5	21.1798/6
45 x 45	21.1788/0	21.1788/2	21.1788/3	21.1788/4	21.1788/5	21.1788/6

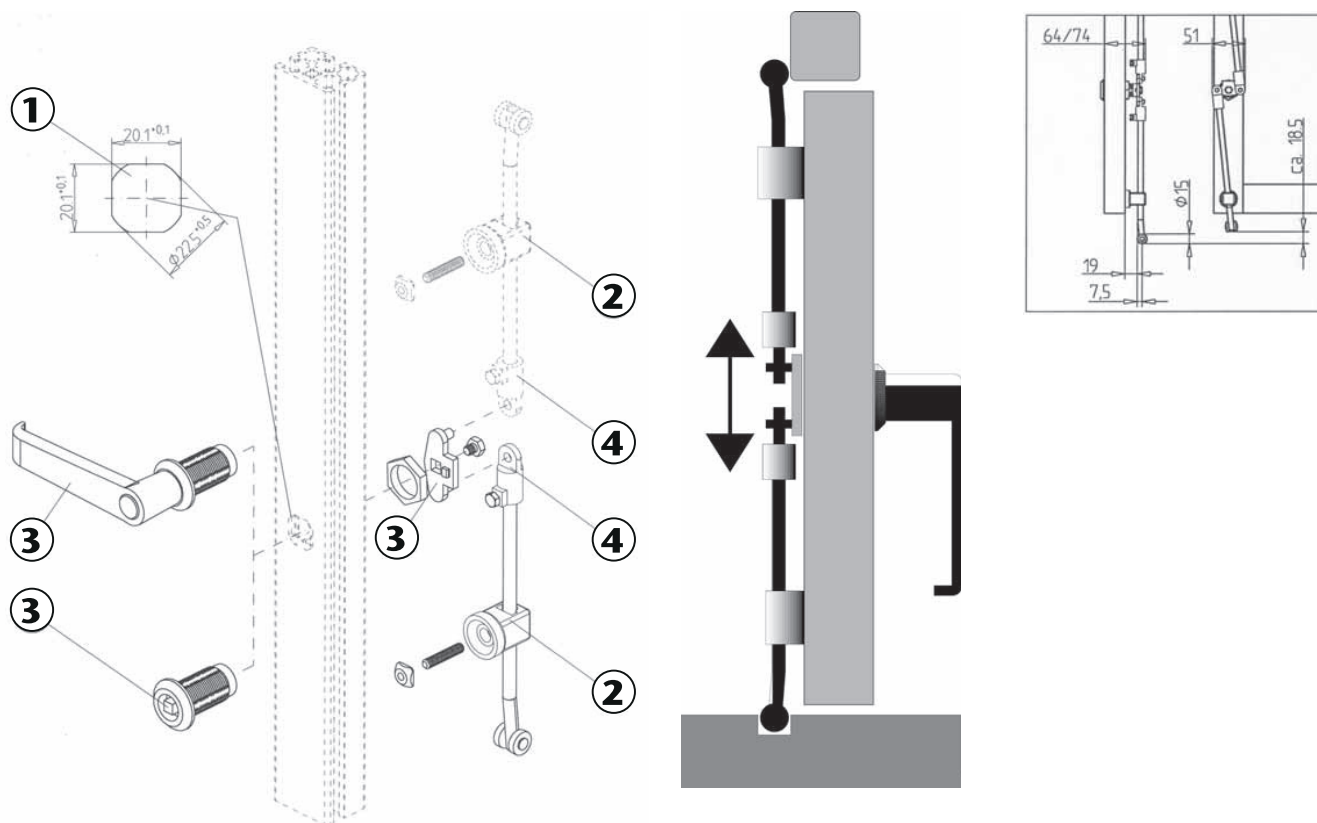

Assembly

1. Insert square recess in vertical door profile
2. Screw in setscrew M6 x 30 in rod guide, screw nut loose onto threaded pin, insert sliding nut in groove and tighten rod guide to position
3. Tighten tongue with cam or handle
4. Insert the ramp in the rod guide and fix it to the tongue

BAR LOCK WITH CASTLE TRAP

TWO-SIDED LOCK WITH LOCK TRAP, PART NO. 21.1490/0

Items Supplied

1. Rod lock insert
2. Handle
3. Lock latch (2 pieces)
4. Adapter for round bars
5. Round bar with eye (Lmax = 1200) (2 pieces)

Optional

Cable duct 45 AL part no. 20.1071/0

Protective cap cable duct 45 part no. 22.1117/1

Cable clip 45 part no. 22.1210/0

Assembly

1. Insert hole \varnothing 13 mm in vertical door profile
2. Attach the bar lock insert and lock latch with sliding nuts to the door profile
3. Shorten the round bars to the appropriate size and connect with lock latch and bar lock insert
4. Insert and fix the handle with square edging
5. Adjust lock latch

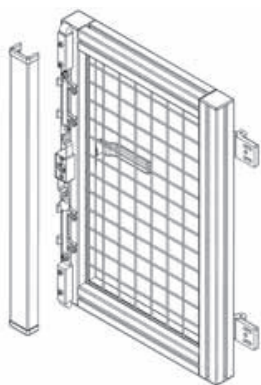

Application

- For closing doors on the upper or lower cross member
- suitable for doors in racks
- max. door height 2750 mm

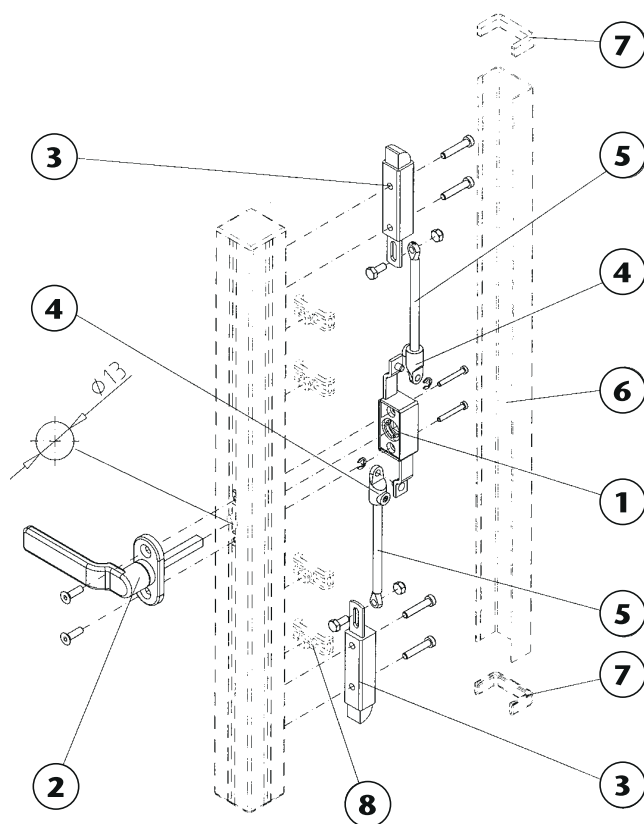

Optional:

Rod cover with cable duct

DOOR LOCK

Part no. 21.1748/0

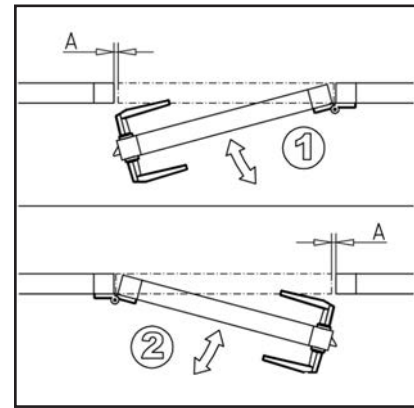
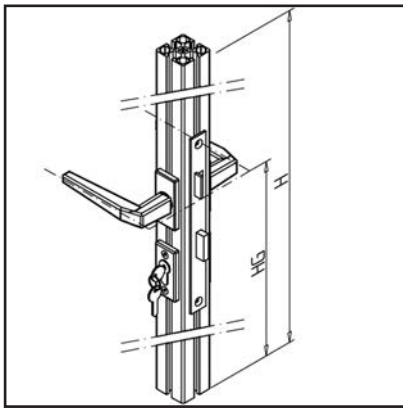

TECHN. DATA / ITEMS SUPPLIED

- Door Lock steel, zinc-plated, fitted in profile 45x45
- Fittings aluminum, anodized
- Profile cylinder with 3 keys, mounted
- **Standard design:** H = 2000mm
HG = 1000mm
- **Other lengths and profiles on request**
- **Please specify dimension H and HG level**
- **Please specify a version 1 or 2**
- Construction set without profile **part no. 21.1748/2**

APPLICATIONS

- Swing doors for guard units
- Other embodiments and profiles on request , for Example, G - sided profile with fixed knob but without lock mounting

ASSEMBLY

- Allow 5mm space between door and frame
- Using lock plate **part no. 21.0966/0** with 10 mm gap
- Closing wedge engages in opposite groove
- If possible, position cross braces outside the lock area or screw in with countersunk screw M8 x 25

LOCK PLATE FOR DOOR LOCK

Part no. 21.0966/0

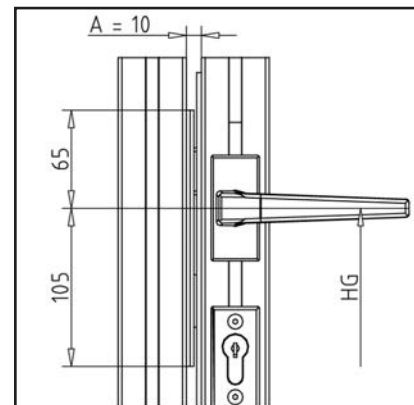
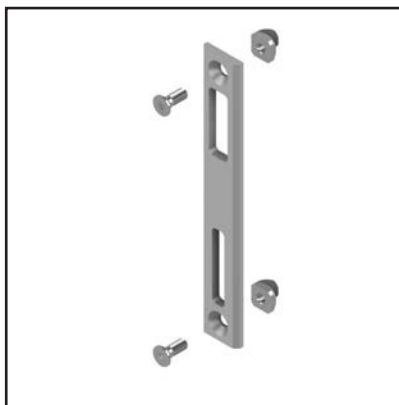
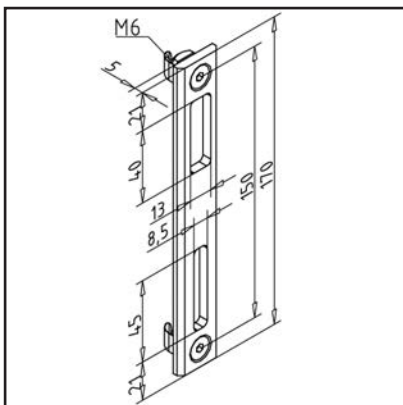

TECHN. DATA / ITEMS SUPPLIED

- Aluminium, anodized E6/EV1
- With fastening material steel, zinc plated
- Weight = 0.061 kg/piece

APPLICATIONS

- To be used in conjunction with door lock **part no. 21.1748/0**
- No post processing on the profile groove of the door post required

ASSEMBLY

- Fasten to profile groove with supplied hardware.
- Door gap at lock 10 mm

ROTARY LOCK 30

Part no. 21.0949/0

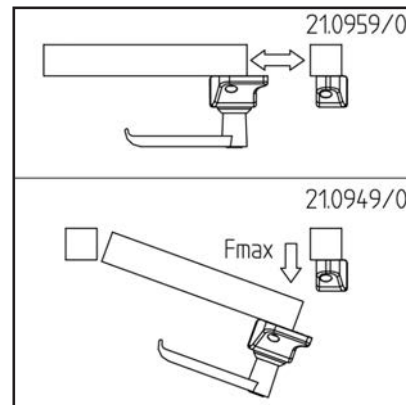
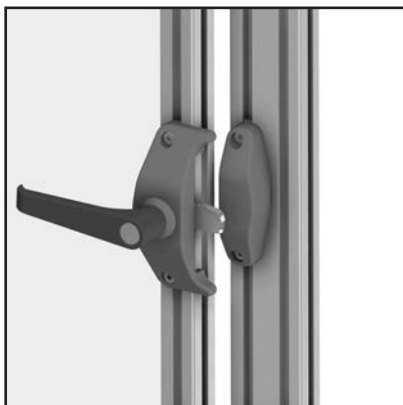
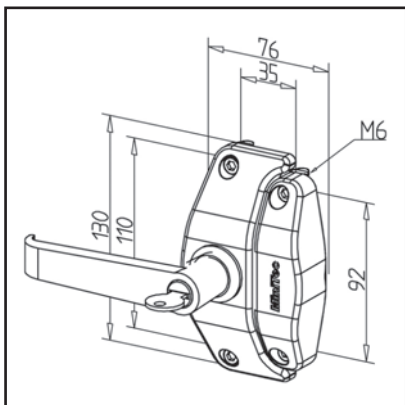

TECHN. DATA / ITEMS SUPPLIED

- Aluminium, Pressure die-casting, powder-coated, grey
- With fastening material steel, zinc plated
- Mounted handle: see **part no. 21.2305/0**
- Fmax. 1000 N
- Weight = 0.432 kg/piece

APPLICATIONS

- Rotary Lock 30 for swing doors: **part no. 21.0949/0**
- Sliding door lock 30 for sliding doors: **part no. 21.0959/0**
- For profiles series 30
- Locking of doors and panels
- No profile finishing required
- Position moveable

ASSEMBLY

- Fasten to profile groove with supplied hardware
- Fastening on profile groove - without processing/boring of profiles

ROTARY LOCK 45

Part no. 21.0948/0

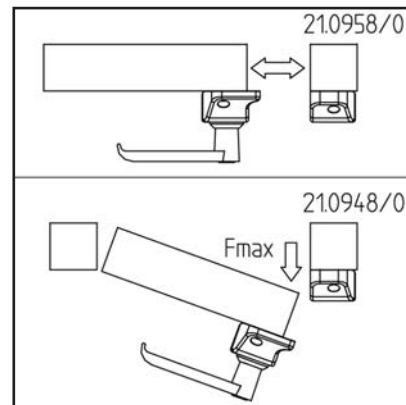
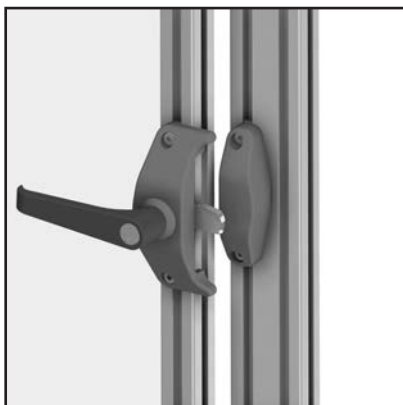
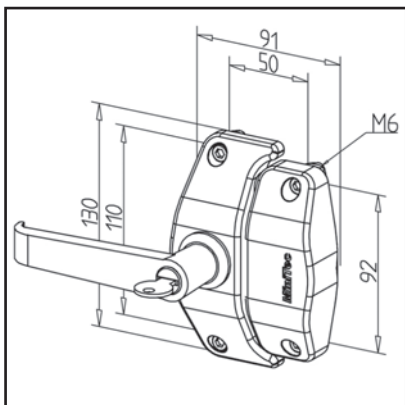

TECHN. DATA / ITEMS SUPPLIED

- With fastening material steel, zinc plated
- Mounted handle: see **part no. 21.2305/0**
- Fmax. 2200 N
- Weight = 0.476 kg/piece

APPLICATIONS

- Rotary lock 45 for swivel doors: **part no. 21.0948/0**
- Sliding door lock 45 for sliding doors **part no. 21.0958/0**
- Locking of doors and panels
- No profile finishing required
- Position moveable

ASSEMBLY

- Fasten to profile groove with supplied hardware
- Fastening on profile groove - without processing/boring of profiles
- No separate door stop required

TRUNK LOCK COMPACT

Part no.

21.2311/0

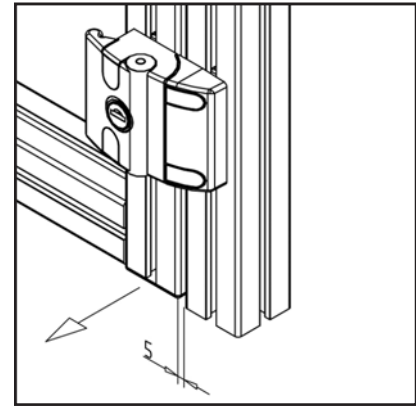
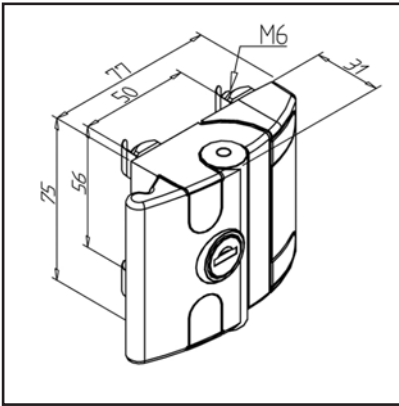

TECHN. DATA / ITEMS SUPPLIED

- Zinc, Pressure die-casting, powder-coated, black
- With fastening material steel, zinc plated
- Locking cylinder with two keys
- Weight = 0.255 kg/piece

APPLICATIONS

- Locking and securing of doors and panels in protective housings
- Door stop at the same time
- Also suitable for frameless doors
- Closed trunk can not be removed

ASSEMBLY

- Mount the latch lock to the door and posts and fit the screw cover
- No machining of the profile is necessary for assembly

TRUNK LOCK WITH AN INQUIRY

Part no.

21.2323/0

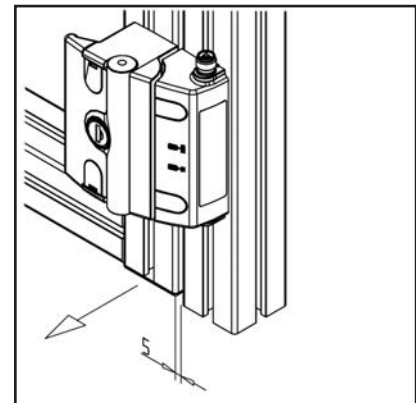
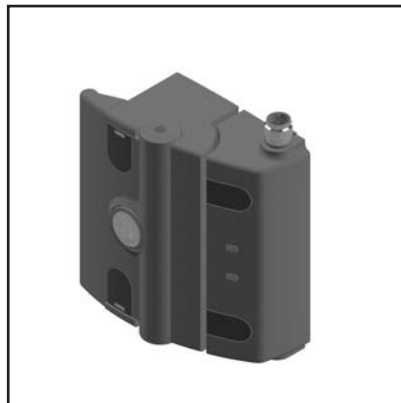
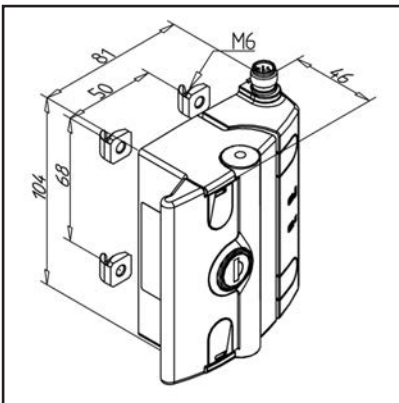

TECHN. DATA / ITEMS SUPPLIED

- Zinc, Pressure die-casting, powder-coated, black
- With fastening material steel, zinc plated
- Locking cylinder with two keys
- Reliability values according to EN ISO 13849-1 category 4 performance Level PLe
- Operating voltage DC24V ±15%
- 2 safety outputs, p-switching, short-circuit protected
- Connection type M12, 8-pin
- UL-approved
- Weight = 0.448 kg/piece

APPLICATIONS

- Locking and securing of doors and hatches Cat. 4/PLe thanks to integrated transponder coded technology
- Door stop at the same time
- Closed trunk can not be removed

ASSEMBLY

- Mount the latch lock to the door and posts and fit the screw cover
- Electrical connection can also be installed at the bottom
- No machining of the profile is necessary for assembly
- Suitable connecting cables on request

BALL LATCH SUPPORT 70

Part no.

21.1137/0

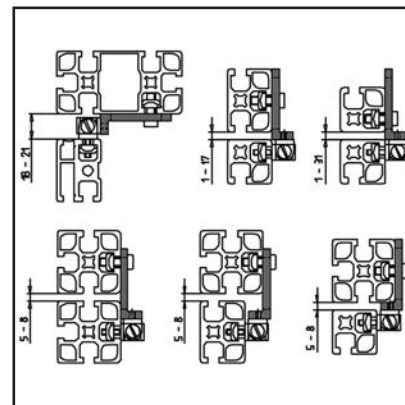
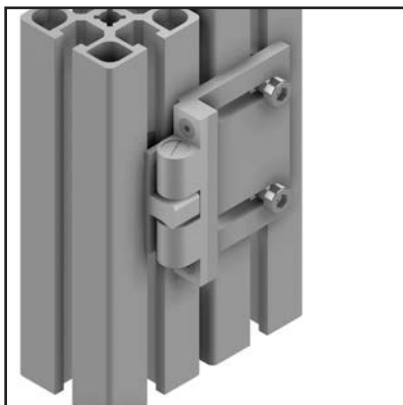
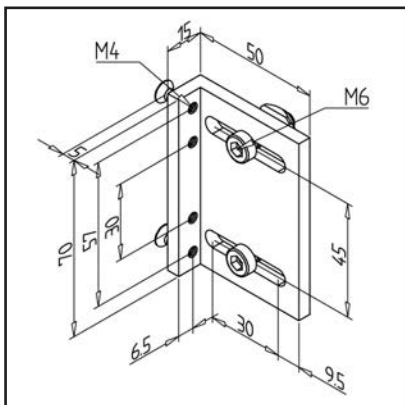

TECHN. DATA / ITEMS SUPPLIED

- Aluminium, anodized E6/EV1
- With fastening material steel, zinc plated
- Use on vertical struts **part no. 21.1137/7** (square nut with position-fixing)
- Weight = 0.050 kg/piece

APPLICATIONS

- Mounting of ball catch 70 in doors, hatches, removable surface elements
- Door stop at the same time
- Shorten the carrier when using profile 32

ASSEMBLY

- Screw tight to the profile groove with supplied hardware.

SNAP BOLT 25

Part no.

21.1758/0

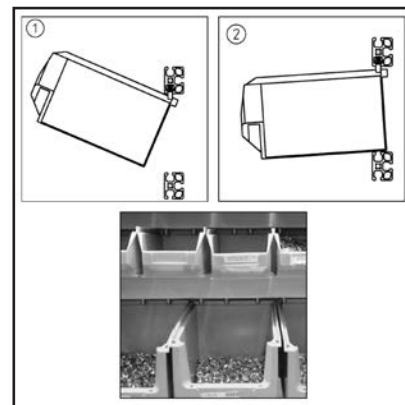
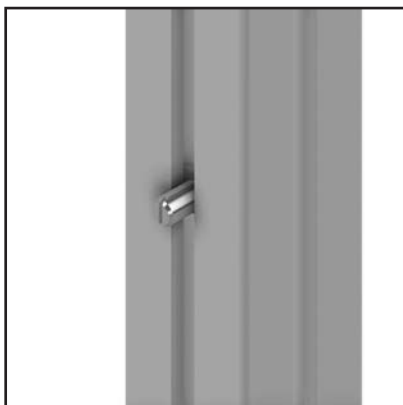
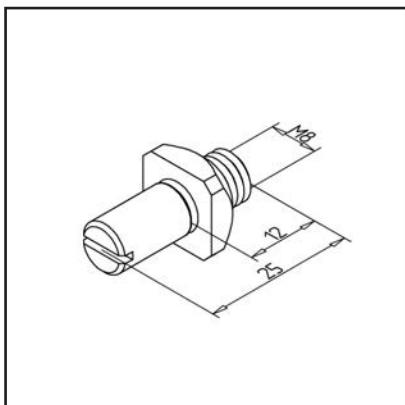

TECHN. DATA / ITEMS SUPPLIED

- Steel, galvanized
- Stainless version **part no. 21.1758/1**
- Weight = 0.012 kg/piece

APPLICATIONS

- Holder of grab containers, oddment boxes
- Support plates

ASSEMBLY

- Tighten in profile groove with sliding nut

SNAP BOLT 40

Part no.

21.1760/0

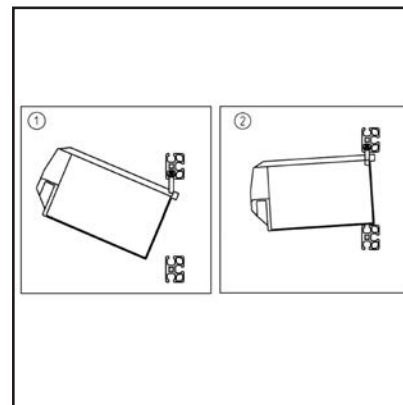
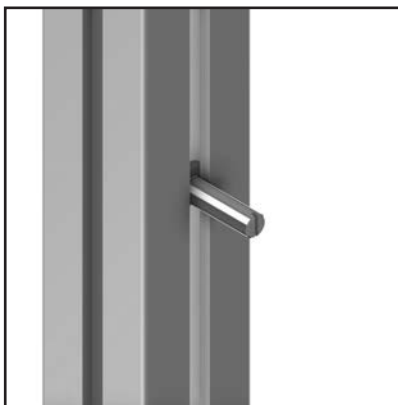
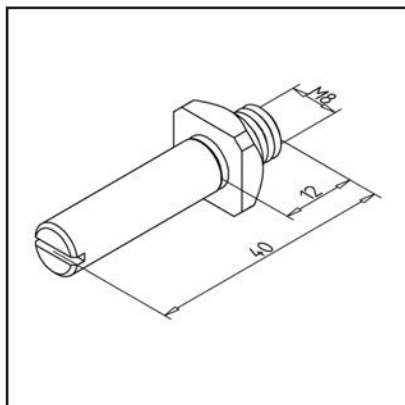

TECHN. DATA / ITEMS SUPPLIED

- Steel, galvanized
- Weight = 0.020 kg/piece

APPLICATIONS

- Holder of grab containers, oddment boxes
- Support plates

ASSEMBLY

- Tighten in profile groove with sliding nut

MAGNETIC CATCH

Part no.

21.1753/0

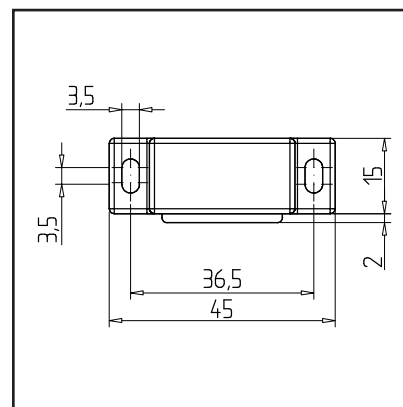
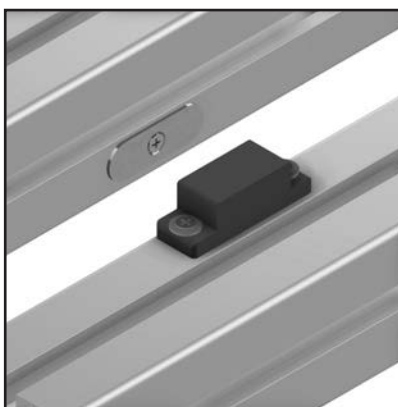
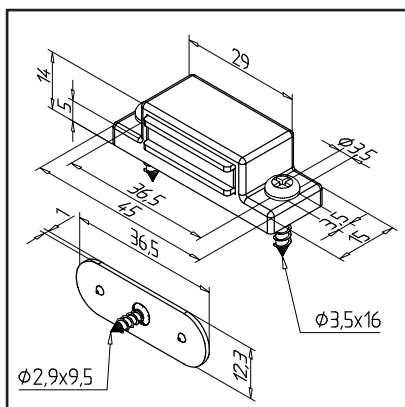

TECHN. DATA / ITEMS SUPPLIED

- PA, black
- Holding plate, steel, zinc plated
- With fastening material steel, zinc plated
- Holding force: 20 N
- Weight = 0.021 kg/piece

APPLICATIONS

- Stop and quick-release of swing doors
- Fastening of light surface elements

ASSEMBLY

- Fasten with fixing material to profile panel

MAGNET PLATE S

Part no.

21.2308/0

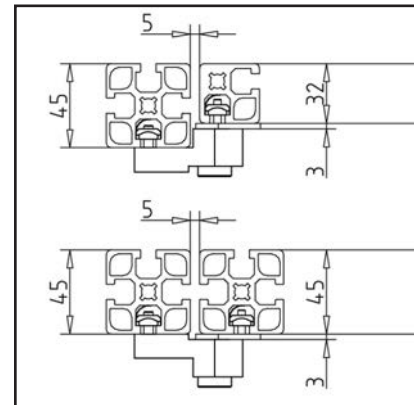
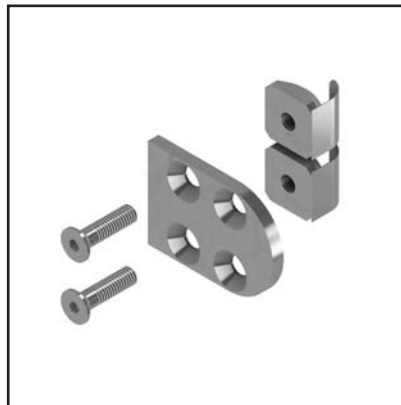
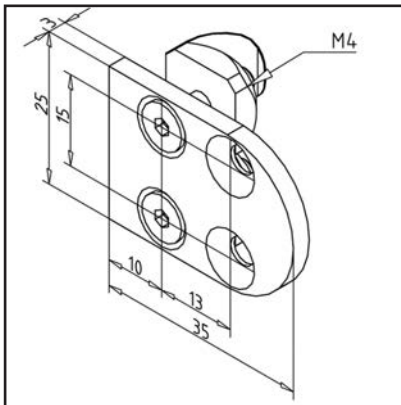

TECHN. DATA / ITEMS SUPPLIED

- Steel, galvanized
- With fastening material steel, zinc plated
- Weight = 0.031 kg/piece

APPLICATIONS

- For magnetic catch S **part no. 21.1740/0**

ASSEMBLY

- Fasten on profile groove
- No drilling required

MAGNET 6 X 9 X 50 MM

Part no.

21.0040/0

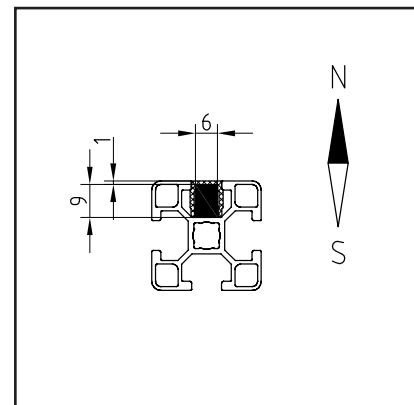
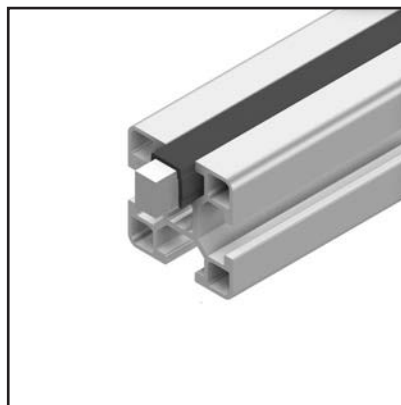
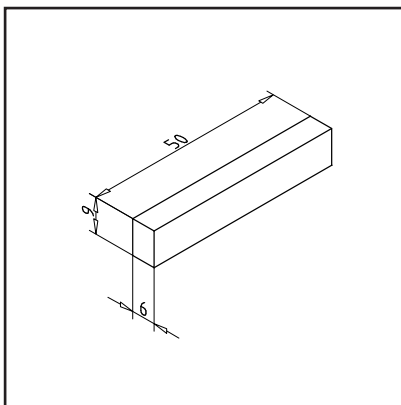

TECHN. DATA / ITEMS SUPPLIED

- NeFeB N45, nickel-plated
- Without fastening kit
- Attention: Electric- and memory devices can be faulted by the magnet
- Power density, $BH_{mx} = 342 \text{ kJ/m}^3$
- Remanence, $B_r = 1320 \text{ mT}$
- coercive field strength $H_{cj} = 955 \text{ kA/m}$
- max. service temperature $+80 \text{ }^\circ\text{C}$
- Weight = 0.023 kg/piece

APPLICATIONS

- Adhesive magnet for tools
- Use under conveyor belts as tracking, for magnetizable conveying products or at higher conveying speeds
- Fitting for all profiles of profile series 30

ASSEMBLY

- Snap or slip the cover profile into profile groove
- Insert magnet into t-slot
- For fastening: (mightily recommended) Use end cap AL, set screw with square nut or t-slot bar

MAGNET 6 X 14 X 50

Part no.

21.0032/0

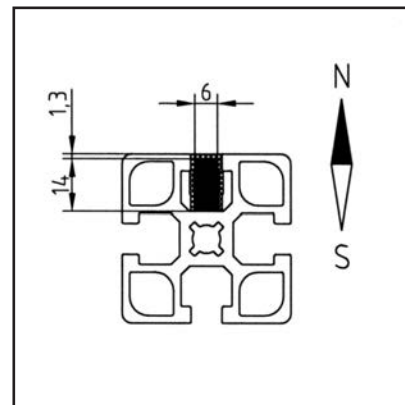
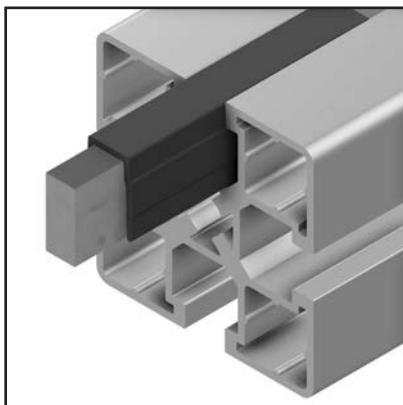
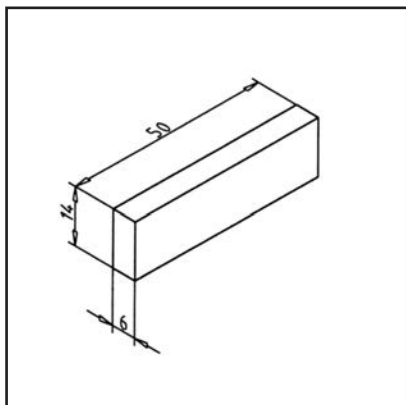
**TECHN. DATA / ITEMS SUPPLIED**

- NeFeB N35, nickel-plated
- Without fastening kit
- Attention: Electric- and memory devices can be faulted by the magnet
- Power density, $BH_{mx} = 263 \text{ kJ/m}^3$
- Remanence, $B_r = 1170 \text{ mT}$
- coercive field strength $H_{cj} = 955 \text{ kA/m}$
- max. service temperature $+80 \text{ }^\circ\text{C}$
- Weight = 0.030 kg/piece

APPLICATIONS

- Adhesive magnet for tools
- Use under conveyor belts as tracking, for magnetizable conveying products or at higher conveying speeds
- Fitting for all profiles of profile series 45

ASSEMBLY

- Snap or slip the cover profile into profile groove
- Insert magnet into t-slot
- For fastening: (mighty recommended) Use end cap AL, set screw with square nut or t-slot bar

STOPPER 25

Part no.

21.1759/0

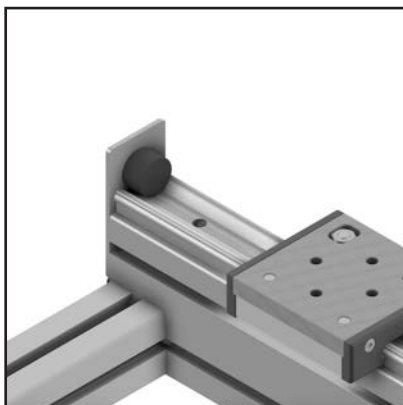
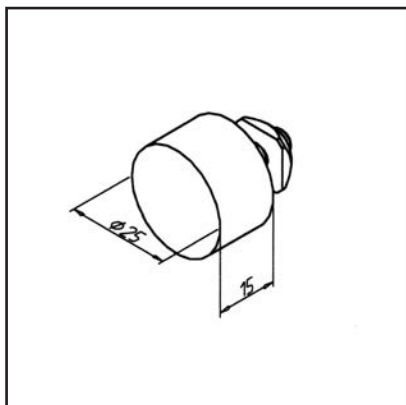
**TECHN. DATA / ITEMS SUPPLIED**

- NBR, black
- With fastening material steel, zinc plated
- With sliding nut M6
- Weight = 0.020 kg/piece

APPLICATIONS

- Stop for doors, linear guides

ASSEMBLY

- Fix with square nut M6 in profile groove

STOPPER 30

Part no.

21.1759/1

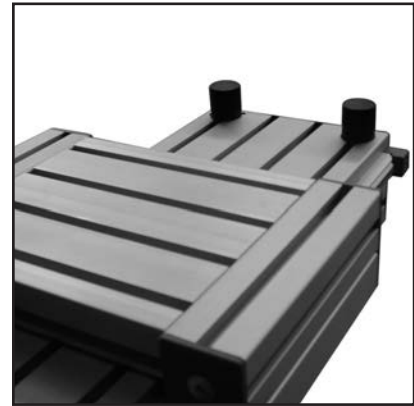
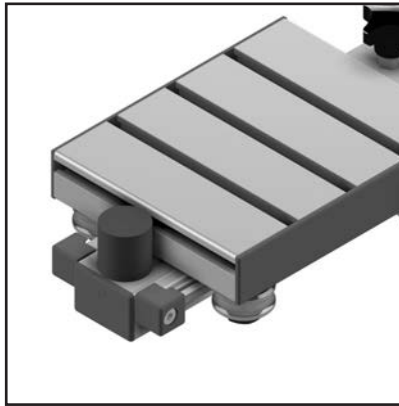
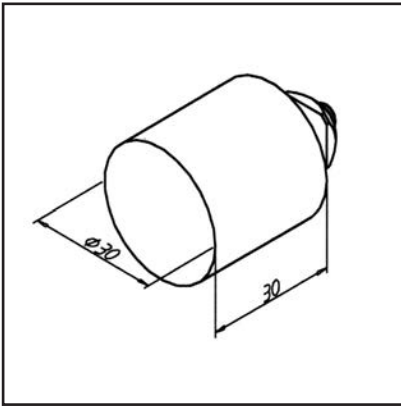

TECHN. DATA / ITEMS SUPPLIED

- NBR, black
- With fastening nut steel, galvanized
- With sliding nut M8
- Weight = 0.060 kg/piece

APPLICATIONS

- Stop for heavy doors, long guides

ASSEMBLY

- Fix with square nut M6 in profile groove

STOPPER 40

Part no.

21.2301/0

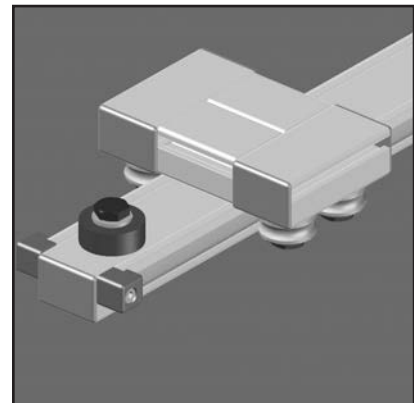
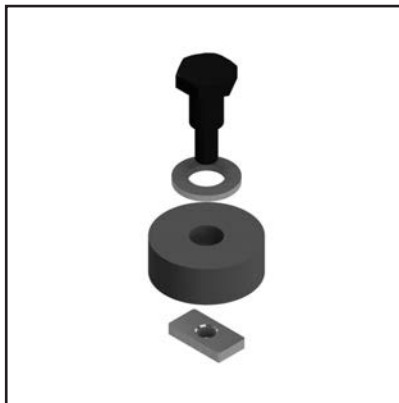
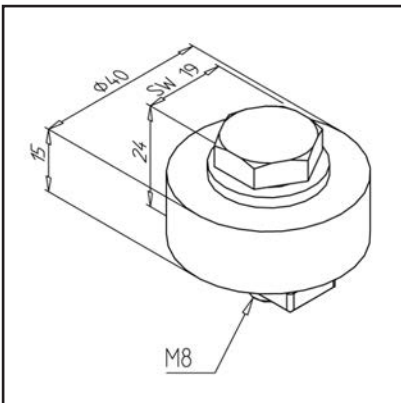

TECHN. DATA / ITEMS SUPPLIED

- NBR, black
- Fixation screw steel, burnished
- Nut and washer steel, galvanised
- With sliding nut M8
- Weight = 0.055 kg/piece

APPLICATIONS

- Stop for heavy doors, long guides

ASSEMBLY

- Fix with square nut M6 in profile groove

CONNECTING PLATES

CONNECTING PLATE 30 x 60



Items Supplied

- Aluminium, powder coated, grey
- Fastening kit

Application

- Fixing of articulated feet and castors on profiles 30x60

Assembly

- Fasten with fastening material from the scope of supply to the profile

THREAD	STRENGTH	WEIGHT	Part no.
M8	15 mm	0,085 kg	21.2114/0
M10	15 mm	0,084 kg	21.2115/0
M12	15 mm	0,082 kg	21.2116/0

CONNECTING PLATE 32 x 90



Items Supplied

- Aluminium, powder coated, grey
- Fastening kit

Application

- Fixing of articulated feet to profiles 90x32 UL

Assembly

- Fasten with fastening material from the scope of supply to the profile

Thread	Thickness	Weight	Part no.
M8	15 mm	0,164 kg	21.1356/0
M10	15 mm	0,162 kg	21.1357/0
M12	15 mm	0,160 kg	21.1358/0

CONNECTING PLATE 45 x 90



Items Supplied

- Aluminium, powder coated, grey
- Fastening kit

Application

Fixing of articulated feet and castors on profiles 45x90

Assembly

Fasten with fastening material from the scope of supply to the profile

Thread	Thickness	Weight	Part no.
M10	15 mm	0,164 kg	21.1038/0
M12	15 mm	0,162 kg	21.1039/0
M16	15 mm	0,160 kg	21.1040/0
M20	15 mm	0,156 kg	21.1047/0

CONNECTING PLATES

CONNECTING PLATE 90 x 90

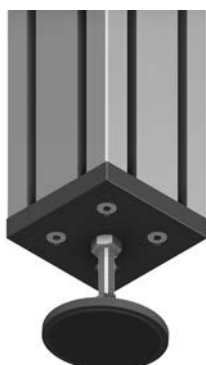

Items Supplied

- Aluminium, powder coated, grey
- Fastening kit

Application

- Fixing of articulated feet and castors on profiles 90x90

Assembly

- Fasten with fastening material from the scope of supply to the profile

Thread	Thickness	Weight	Part no.
M10	15 mm	0,332 kg	21.1041/0
M12	15 mm	0,330 kg	21.1042/0
M16	15 mm	0,345 kg	21.1043/0
M20	15 mm	0,290 kg	21.1057/0

CONNECTING PLATE 90 R 90°



Items Supplied

- Aluminium, powder coated, grey
- Fastening kit

Application

- Fixing of articulated feet and castors on profiles 90R90°

Assembly

- Fasten with fastening material from the scope of supply to the profile

Thread	Thickness	Weight	Part no.
M10	15 mm	0,277 kg	21.0009/0
M12	15 mm	0,275 kg	21.0010/0
M16	15 mm	0,272 kg	21.0011/0
M20	15 mm	0,268 kg	21.0012/0

HINGED FEET

HINGED FEET PA

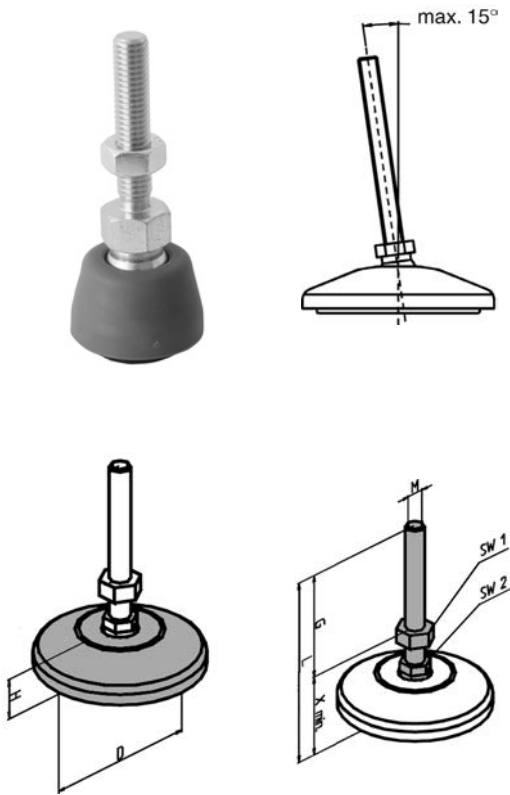

Items Supplied

- Plate PA, grey
- Anti slip insert NBR
- Spindle steel, galvanized
- Lock nut steel, galvanized
- All spindles fit all plates

Application

Height adjustable constructions of all kinds
 Protective equipment, tables, showcases
 Conveyors, system workstations

Assembly

- Direct in central drilling of the profiles (depending on profile cross-section drilled up to thread M12)
- Larger threads in connection with connection plate
- For profiles 45 x 90 and 90 x 90, a connection plate is required if the feet should be positioned centrally

Spindle	Plate			
	Ø 30	Ø 45	Ø 60	Ø 80
M8	21.1851/0	21.1871/0	21.1881/0	21.1891/0
M10	21.1852/0	21.1872/0	21.1882/0	21.1892/0
M12	-	21.1873/0	21.1883/0	21.1893/0
M16	-	21.1874/0	21.1884/0	21.1894/0

Plate		
D mm	H mm	Load capacity
30	20	300 kg
45	20	500 kg
60	20	1000 kg
80	20	1000 kg

Spindle					
M	G	X	SW1	SW2	L
8	33,5	38,5	13	14	72,5
10	42	40,5	17	14	82,5
12	90	42,5	19	14	132,5
16	107	45,5	24	17	152,5

HINGED FEET PA WITH MOUNTING HOLE

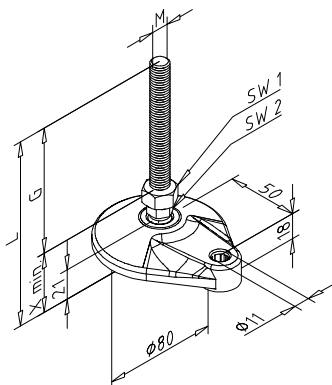

Items Supplied

- Plate PA, grey
- Spindle Steel, galvanized
- Lock nut steel, galvanized
- Anti slip insert NBR
- Load capacity: 1000 Kg

Part no.	Color	M	G	X	SW1	SW2	L
21.2510/0	grey	08	33,5	39	13	14	72,5
21.2511/0	grey	10	42	40,5	17	14	82,5
21.2512/0	grey	12	90	42,5	19	14	132,5
21.2513/0	grey	16	107	45,5	24	17	152,5

HINGED FEET

HINGED FEET GD

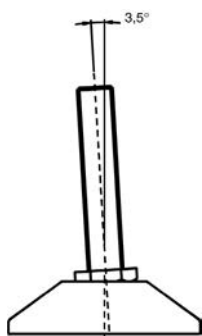

Items Supplied

- Plate die-cast aluminium powder-coated, grey
- Anti slip insert NBR
- Spindle Steel, galvanized
- Lock nut steel, galvanized
- All spindles fit all plates

Spindle	Plate	
	Ø 45	Ø 90
M10	21.1842/0	21.1862/0
M12	21.1843/0	21.1863/0
M16	21.1844/0	21.1864/0

Plate		
D mm	H mm	Load capacity
45	25	3000 kg
90	27	4000 kg

Spindle					
M	G	X	SW1	SW2	L
10	52,6	37,5	17	17	89,5
12	50,5	41	19	19	91,2
16	68	45,6	24	24	112,6

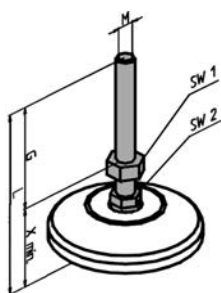
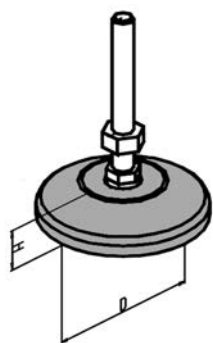

FOOT SST

Part no. 21.2053/0

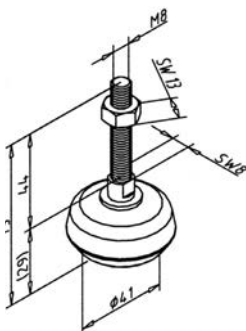

Items Supplied

- Plate Steel, VA
- Spindle insert steel VA
- Lock nut steel, VA
- Load capacity: 750 kg

Application

- Height adjustable constructions of all kinds
- Protective equipment, tables, showcases
- Conveyors, system workstations

Assembly

- Directly in central bore of the profiles, also in VA profile
Cut thread M8,
Mold in aluminum profile thread M8

CLIP - BLOCK FOR BALL HEAD

Part no.

22.1181/0

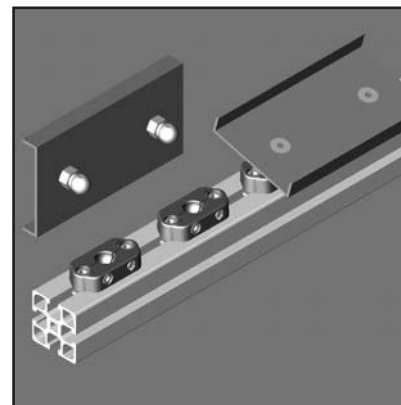
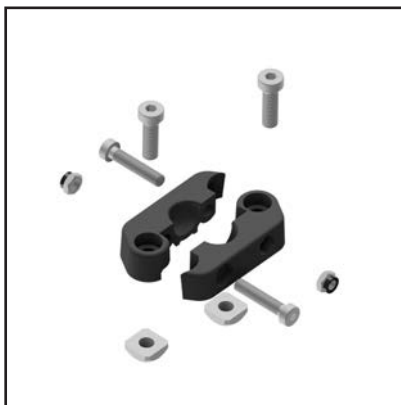
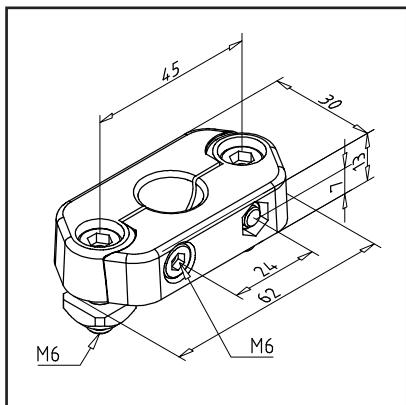

TECHN. DATA / ITEMS SUPPLIED

- PA, Injection Mould, grey
- Ball Ø15 mm
- With fastening material steel, zinc plated
- Swivel area 15°
- Load capacity up to 150 kg standing vertically
- Weight = 0.054 kg/piece

APPLICATIONS

- For the preparation of self-adjusting lines and stoppers
- Exchangeable workpiece or worktool carriers
- To be used with ball head M8 **part no. 21.2506/0** or the ball screws made of hinged feet PA

ASSEMBLY

- Fasten with fixing material to profile groove
- Holding force adjustable 0 - 50 N

BALL HEAD M8

Part no.

21.2506/0

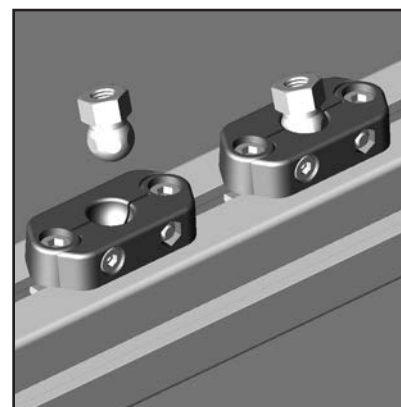
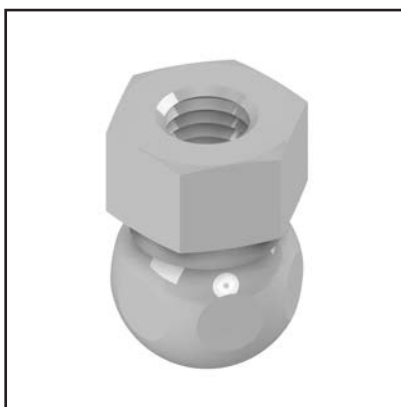
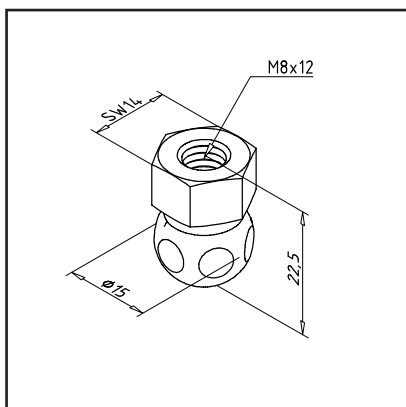

TECHN. DATA / ITEMS SUPPLIED

- Steel, galvanized
- Ball Ø15 mm
- Internal thread M8x12
- Weight = 0.020 kg/piece

APPLICATIONS

- For use in combination with Clip Block **part no. 22.1181/0**
- For the preparation of linings or hinged feet in special design, see hinged feet PA

ASSEMBLY

- Fasten onto preferred component with screw M8
- Use for fastening to profile groove setscrew M8x20 and square nut M8

FOOT 30 COMPACT

Part no.

21.2524/0

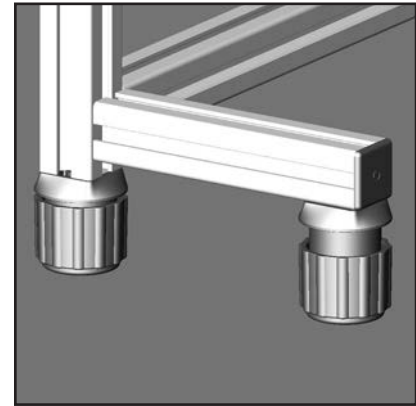
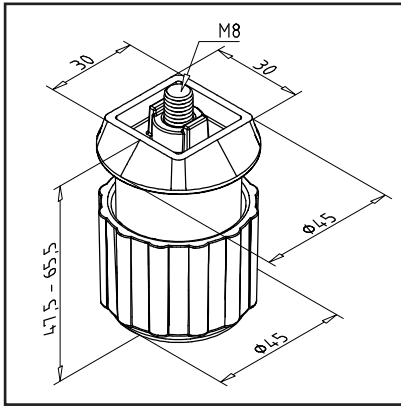

TECHN. DATA / ITEMS SUPPLIED

- PA, Injection Mould, grey
- With fastening material steel, zinc plated
- Max. load capacity: 100 Kg
- Adjustment area ± 9 mm
- With anti-skid rubber damper
- Weight = 0.121 kg/piece

APPLICATIONS

- For installation and levelling of smaller frames with nice design

ASSEMBLY

- Assembly with to profile end or on profile face with delivered fixation material

FOOT 45 COMPACT

Part no.

21.2525/0

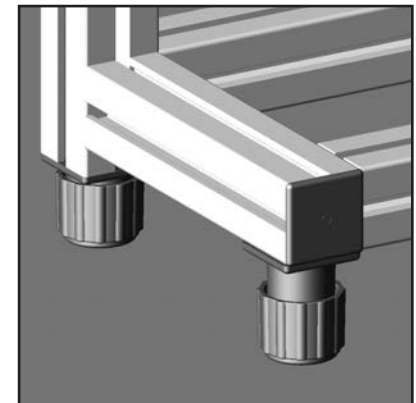
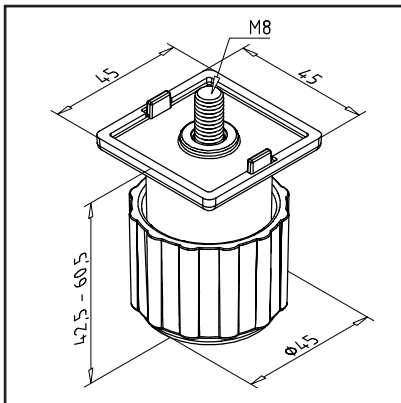

TECHN. DATA / ITEMS SUPPLIED

- PA, Injection Mould, grey
- With fastening material steel, zinc plated
- Max. load capacity: 100 Kg
- Adjustment area ± 9 mm
- With anti-skid rubber damper
- Weight = 0.117 kg/piece

APPLICATIONS

- For installation and levelling of smaller frames with nice design

ASSEMBLY

- Assembly with to profile end or on profile face with delivered fixation material

FLOOR MOUNTING PLATE 45X45 G

Part no.

22.1217/0

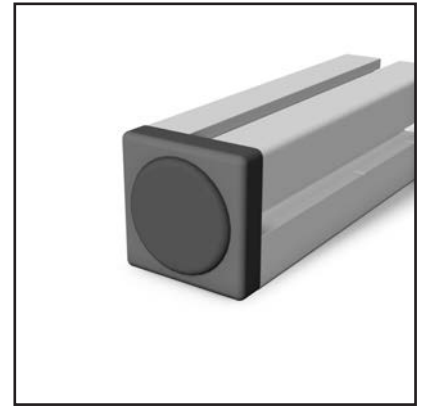
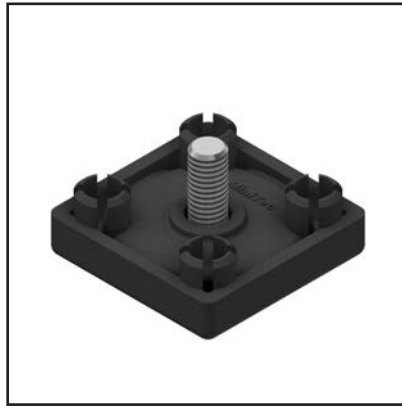
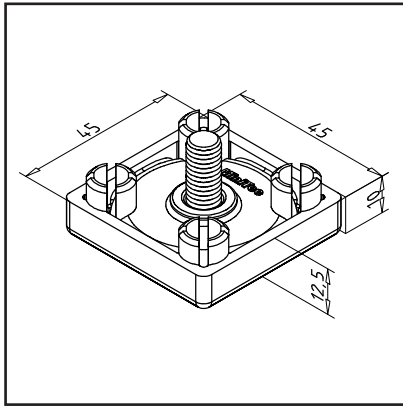

TECHN. DATA / ITEMS SUPPLIED

- ABS, Injection Mould, grey
- Anti-slip license NBR, black
- With fastening screw M8, galvanized
- Load capacity: 1000 kg
- Weight = 0.032 kg/piece

APPLICATIONS

- For use with all profiles with cross section 45x45
- For non-slip installation of tables and racks
- Reduces noise and protects the floor

ASSEMBLY

- Fasten to central profile bore with fixation material from delivery scope
- then insert anti-slip certificate

FURNITURE WHEEL WITH LOCKING DEVICE

Part no.

21.1153/0

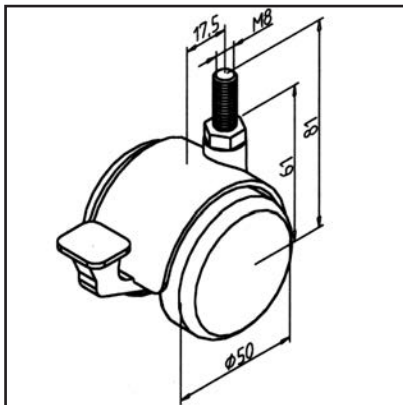

TECHN. DATA / ITEMS SUPPLIED

- PA, black
- Double role with sliding bearing
- With fastening material steel, zinc plated
- Load capacity 30 kg
- Weight = 0.080 kg/piece

APPLICATIONS

- Light movable tables
- Movable file box
- Furniture

ASSEMBLY

- Install directly in the center hole of the vertical profile with mounting material
- If the wheel must be positioned centrally for profile cross-sections 45 x 90 or greater, a base and transport plate with thread M8 is required

FURNITURE WHEEL WITHOUT LOCKING DEVICE

Part no. 21.1105/0

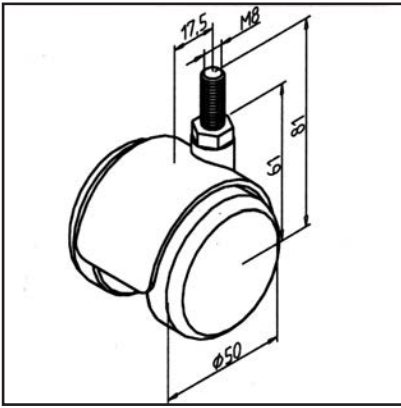

TECHN. DATA / ITEMS SUPPLIED

- PA, black
- Double role with sliding bearing
- With fastening material steel, zinc plated
- Load capacity 30 kg
- Weight = 0.076 kg/piece

APPLICATIONS

- Light movable tables
- Movable file box
- Furniture

ASSEMBLY

- Install directly in the center hole of the vertical profile with mounting material
- If the wheel must be positioned centrally for profile cross-sections 45 x 90 or greater, a base and transport plate with thread M8 is required

SWIVELLING CASTOR WITH BRAKE D 75 X 100

Part no. 21.1120/0

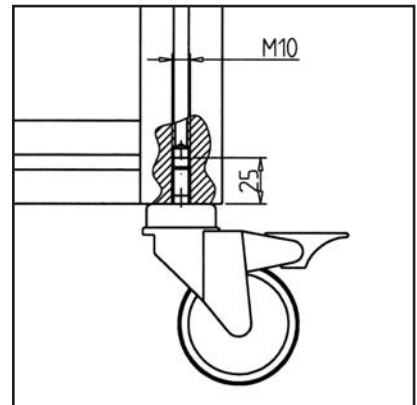
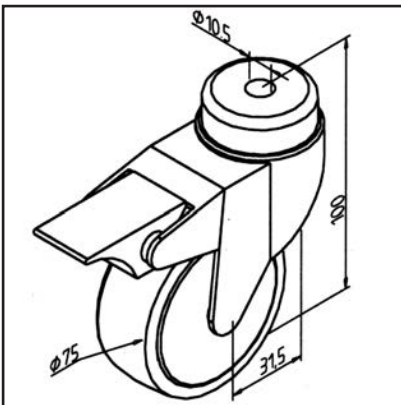

TECHN. DATA / ITEMS SUPPLIED

- Steel, galvanized
- Tire, rubber, grey
- With fastening material steel, zinc plated
- Load capacity 50 kg
- **Other versions upon request**
- Weight = 0.450 kg/piece

APPLICATIONS

- Movable tables
- Work stands
- display windows, showcases

ASSEMBLY

- Attach directly to the central bore of the vertical profile with fastening material, then drill and introduce thread M10
- A connection plate is required if the roller is to be positioned centrally with profile cross sections 45 x 90 or 90 x 90

SWIVELLING CASTOR WITHOUT BRAKE D 75 X 100

Part no.

21.1118/0

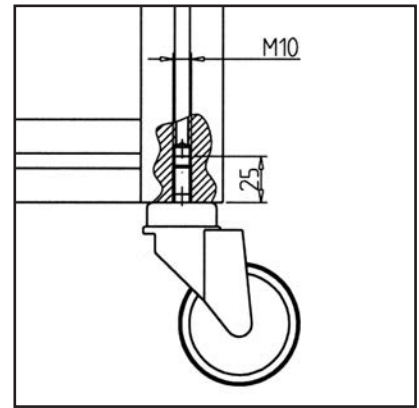
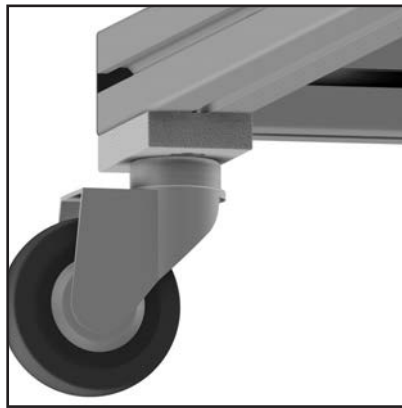
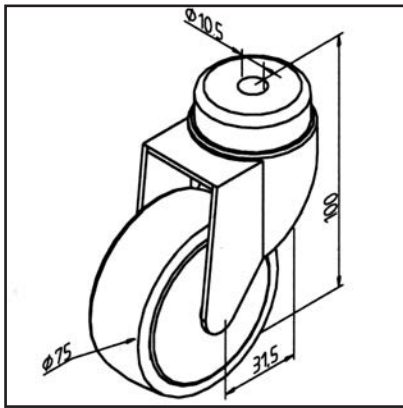

TECHN. DATA / ITEMS SUPPLIED

- Steel, galvanized
- Tire, rubber, grey
- With fastening material steel, zinc plated
- Load capacity 50 kg
- **Other versions upon request**
- Weight = 0.372 kg/piece

APPLICATIONS

- Movable tables
- Work stands
- display windows, showcases

ASSEMBLY

- Attach directly to the central bore of the vertical profile with fastening material, then drill and introduce thread M10
- A connection plate is required if the roller is to be positioned centrally with profile cross sections 45 x 90 or 90 x 90

FIXED CASTOR D 75 X 103

Part no.

21.1475/0

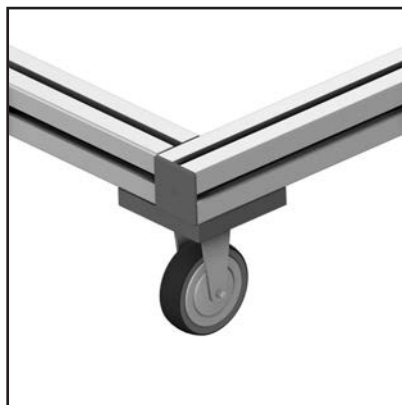
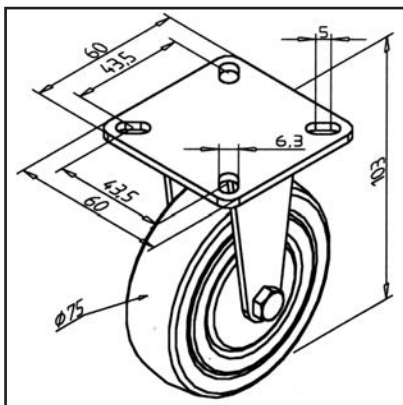

TECHN. DATA / ITEMS SUPPLIED

- Steel, galvanized
- Tire, rubber, grey
- With fastening material steel, zinc plated
- Load capacity 50 kg
- **Other versions upon request**
- Weight = 0.350 kg/piece

APPLICATIONS

- Work stands
- Frames
- Movable tables

ASSEMBLY

- to the profile groove with supplied hardware
- With mounting plate for castor **Part no. 21.1476/0** attach to profile

CONNECTING PLATE 45 X 45 VA M10

Part no.

21.2059/0

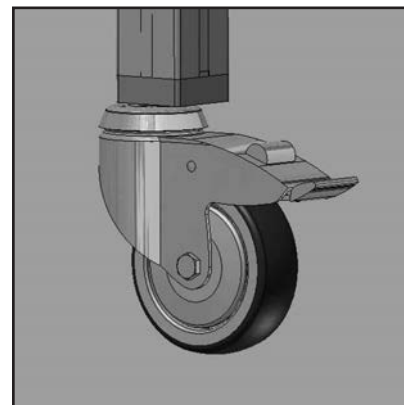
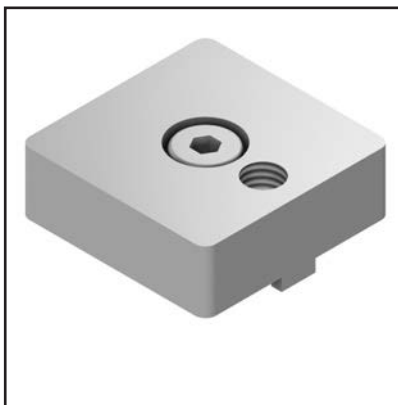
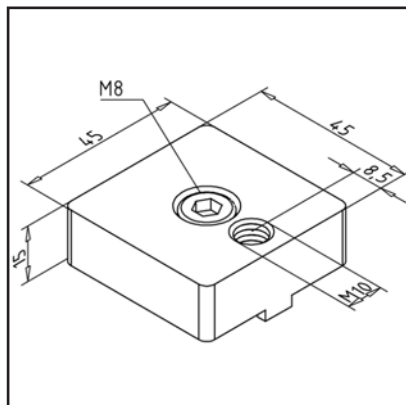

TECHN. DATA / ITEMS SUPPLIED

- Stainless steel
- Fastening kit
- Weight = 0.230 kg/piece

APPLICATIONS

- PROFILE 45 x 45
- Profile 45 x 45 VA
- Height compensation when mounting casters in combination with fixed casters on a movable base frame
- For using feet M10

ASSEMBLY

- Front attachment to profile with supplied hardware
- Fasten to profile with fastening material from the scope of delivery

FASTENING PLATE 45 SST TO FIXED CASTOR

Part no.

21.2058/0

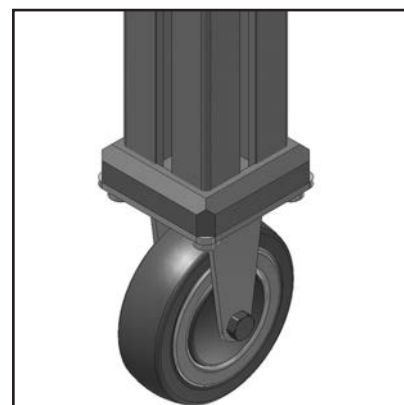
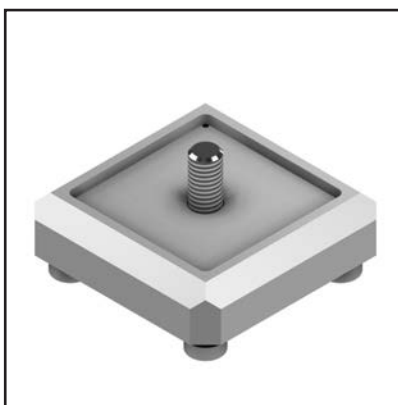
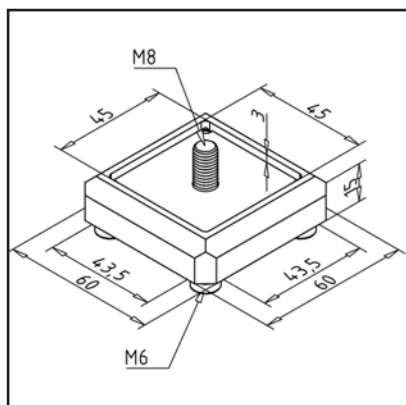

TECHN. DATA / ITEMS SUPPLIED

- Stainless steel
- Fastening kit
- Weight = 0.360 kg/piece

APPLICATIONS

- PROFILE 45 x 45
- Profile 45 x 45 VA
- For attaching the fixed caster on the front side to profile 45 x 45 and 45 x 45 VA

ASSEMBLY

- Front attachment to profile with supplied hardware

FASTENING PLATE 90 TO FIXED CASTOR

Part no. 21.1476/0

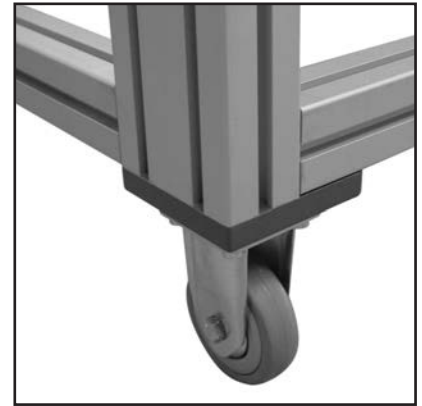
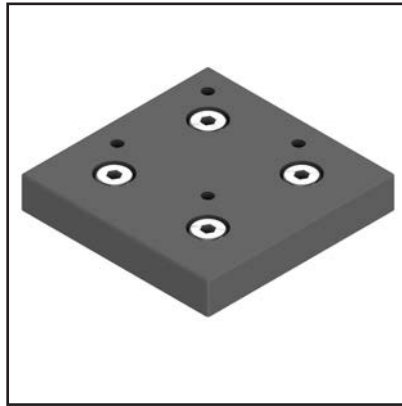
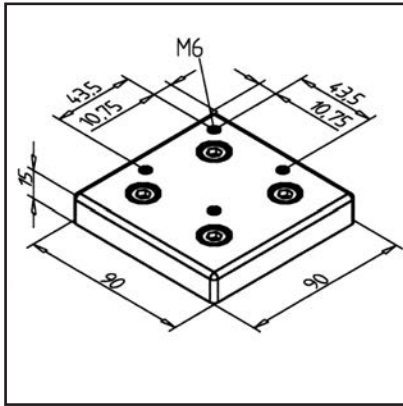

TECHN. DATA / ITEMS SUPPLIED

- Aluminium, Pressure die-casting, powder-coated, grey
- With fastening material steel, zinc plated
- Weight = 0.330 kg/piece

APPLICATIONS

- To attach the castor **part no. 21.1475/0** frontally to profile 90 x 90

ASSEMBLY

- Fasten to the profile end with supplied hardware

SWIVELLING CASTOR WITH BRAKE D 100 X 131

Part no. 21.0031/0

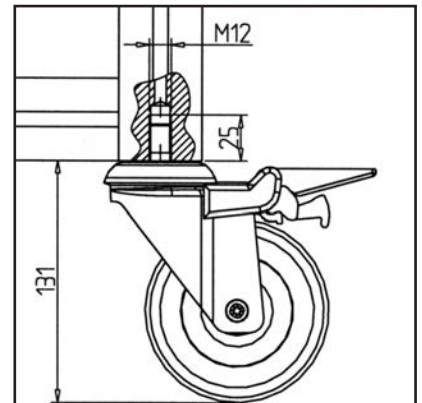
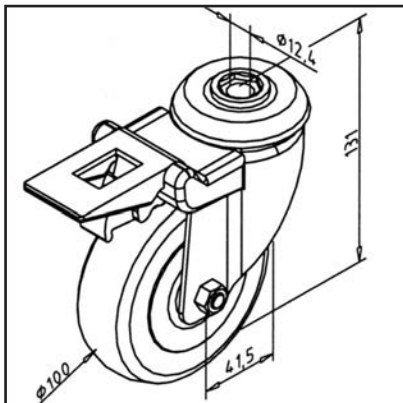

TECHN. DATA / ITEMS SUPPLIED

- Steel, galvanized
- Tire, rubber, grey
- With fastening material steel, zinc plated
- Load capacity 100 kg
- **Other versions upon request**
- Weight = 0.743 kg/piece

APPLICATIONS

- Movable tables
- Work stands
- display windows, showcases

ASSEMBLY

- Connect directly to the central bore of the vertical profile with supplied hardware, drill and introduce thread M12
- If the roller is to be centrally positioned for profile cross sections of 45 x 90 or 90 x 90, a connection plate is required

SWIVELLING CASTOR WITHOUT BRAKE D 100 X 131

Part no.

21.0030/0

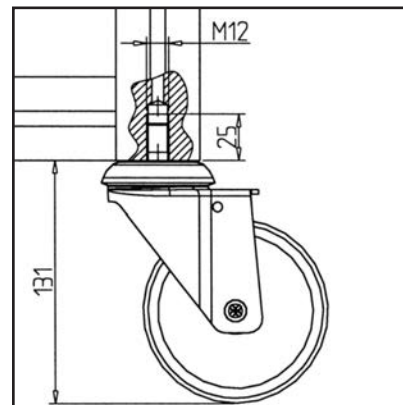
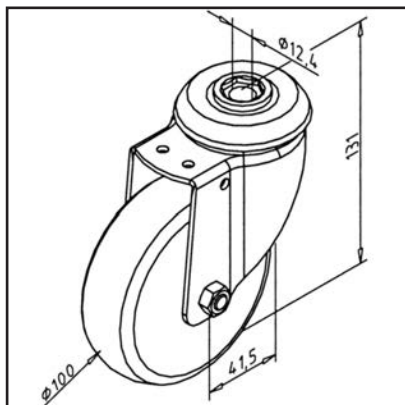

TECHN. DATA / ITEMS SUPPLIED

- Steel, galvanized
- Tire, rubber, grey
- With fastening material steel, zinc plated
- Load capacity 100 kg
- **Other versions upon request**
- Weight = 0.660 kg/piece

APPLICATIONS

- Movable tables
- Work stands
- display windows, showcases

ASSEMBLY

- Connect directly to the central bore of the vertical profile with supplied hardware, drill and introduce thread M12
- A connection plate is required if the roller is to be positioned centrally with profile cross sections 45 x 90 or 90 x 90

FLOOR MOUNTING PLATE 45

Part no.

21.1730/0

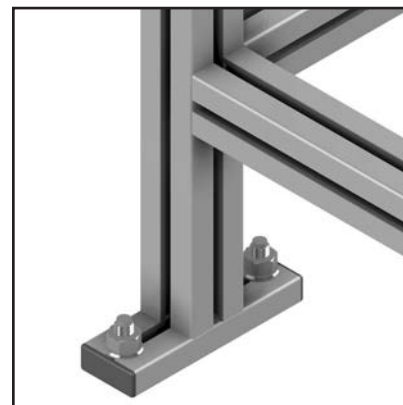
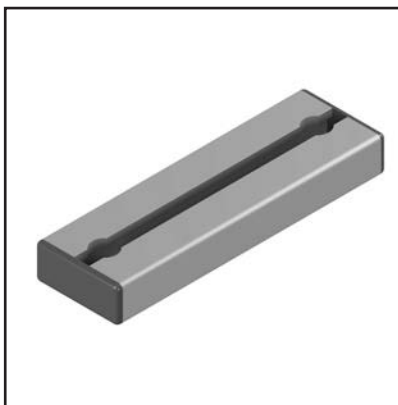
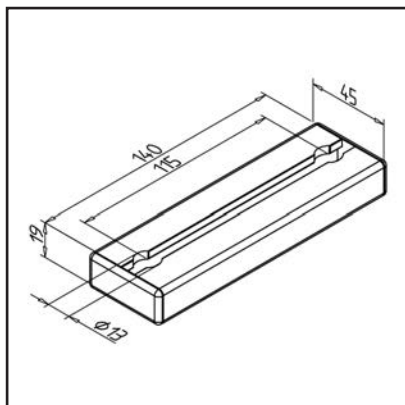

TECHN. DATA / ITEMS SUPPLIED

- Aluminium, anodized E6/EV1
- PROFILE 45 x 19
- With caps, grey
- Without fastening kit
- Weight = 0.130 kg/piece

APPLICATIONS

- Floor fixing of columns from profile 45 x 45

ASSEMBLY

- Secure profile with MiniTec profile connector
- On floor side: 2 floor anchors **part no. 21.1082/0**

FLOOR MOUNTING PLATE 90

Part no. 21.1733/0

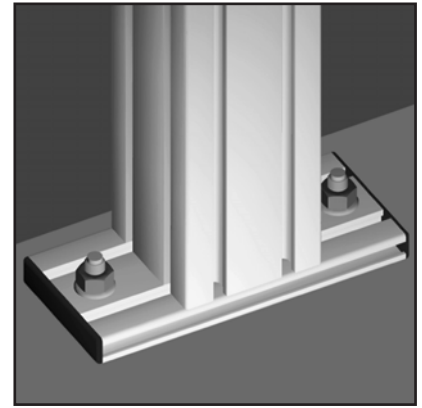
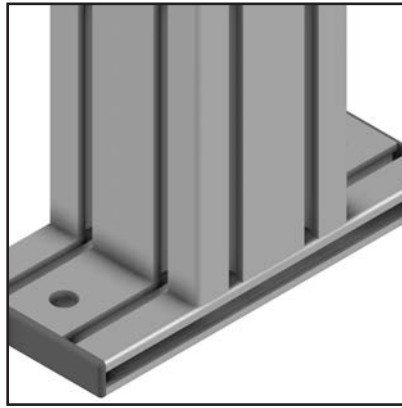
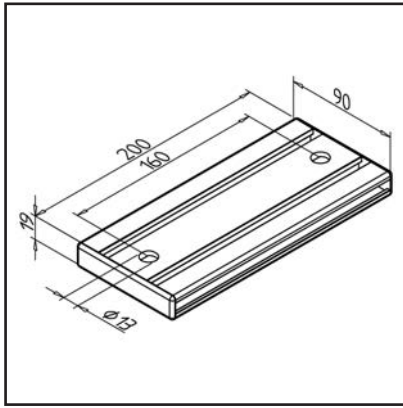

TECHN. DATA / ITEMS SUPPLIED

- Aluminium, anodized E6/EV1
- PROFILE 19 X 90
- With caps, grey
- Without fastening kit
- Weight = 0.470 kg/piece

APPLICATIONS

- Floor fixing of columns from profile 45 x 90 oder 90 x 90

ASSEMBLY

- On profile side: 2 or 4 MiniTec power-lock fasteners
- On floor side: 2 floor anchors **part no. 21.1082/0**

FLOOR ANCHOR 10

Part no. 21.1082/0

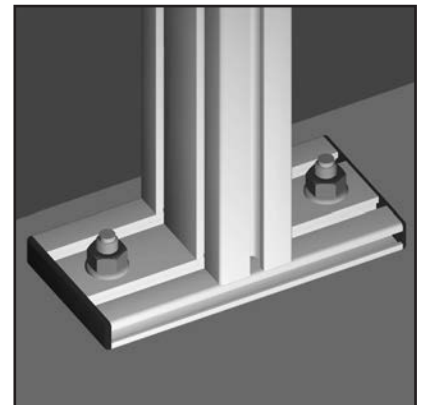
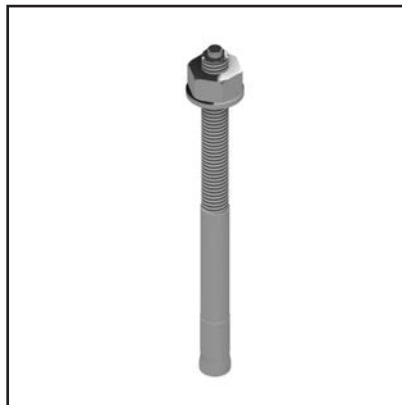
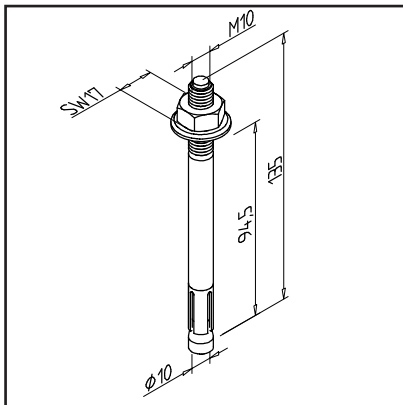

TECHN. DATA / ITEMS SUPPLIED

- Steel, galvanized
- Ø 10
- With hexagonal nut and washer
- Weight = 0.084 kg/piece

APPLICATIONS

- Secure and fasten constructions in connection with the floor mounting bracket, levelling plate or stationary plate

ASSEMBLY

- Fit bore in the bottom
- Use floor anchor in connection with angle, levelling plate or floor mounting plate

FLOOR ANCHOR 12

Part no.

21.1115/0

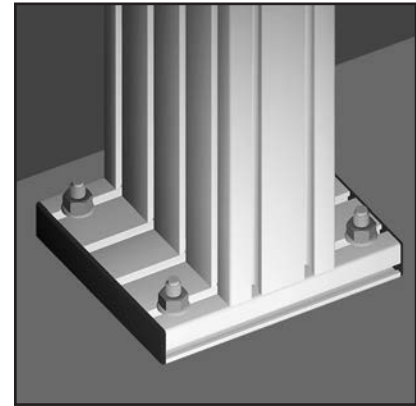
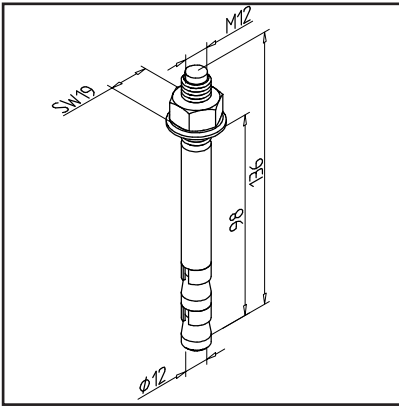

TECHN. DATA / ITEMS SUPPLIED

- Steel, galvanized
- Ø 12
- With hexagonal nut and washer
- Weight = 0.116 kg/piece

APPLICATIONS

- Secure and fasten constructions in connection with the floor mounting bracket, leveling plate or stationary plate

ASSEMBLY

- Fit bore in the bottom
- Use floor anchor in connection with angle, levelling plate or floor mounting plate

LEVELING PLATE 90 ST

Part no.

21.0976/0

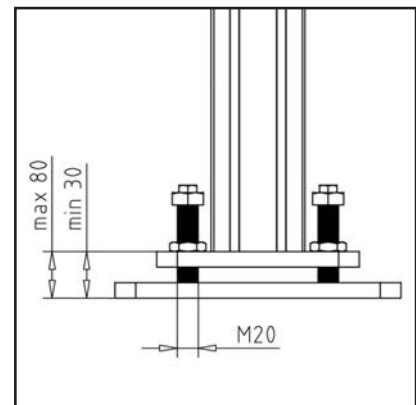
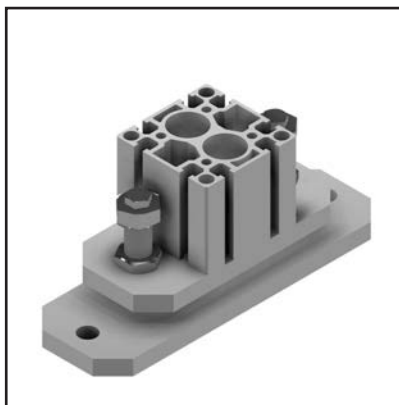
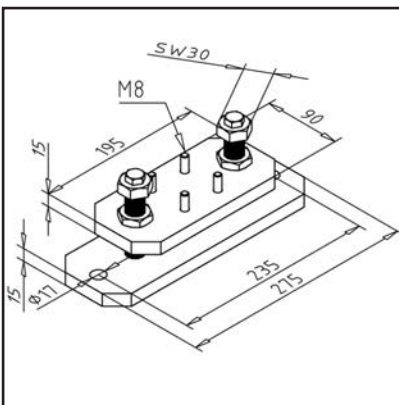

TECHN. DATA / ITEMS SUPPLIED

- Steel, galvanized
- With galvanized steel fastening material, for profile
- With leveling element
- Without dowels
- Weight = 5.146 kg/piece

APPLICATIONS

- Precise alignment of heavy constructions with cross-section 90x90 as post profile

ASSEMBLY

- Fasten footplate to the floor using a high performance anchor
- Fasten profile plate to the profile with supplied hardware
- Turn the M20 screw to set the height and secure it with the counter nut

LEVELING PLATE 180 ST

Part no.

21.0977/0

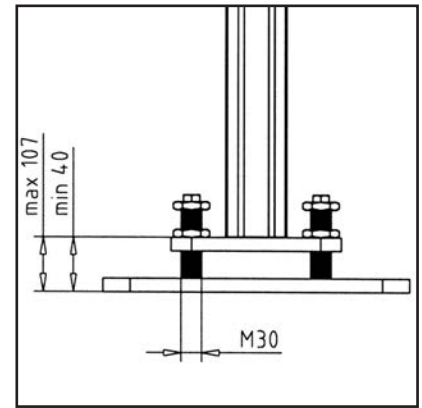
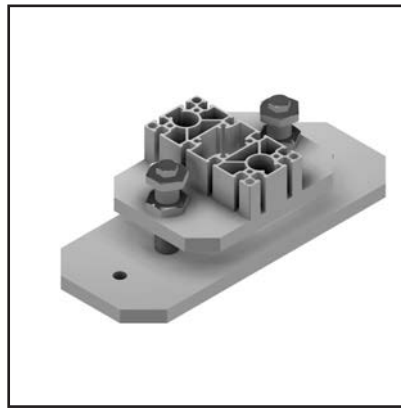
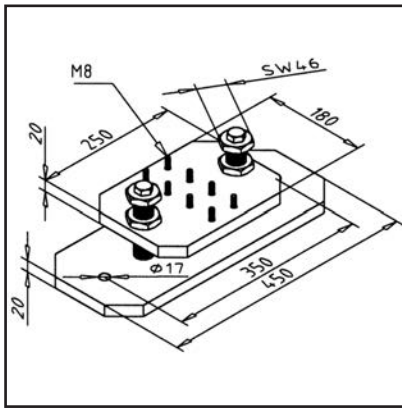

TECHN. DATA / ITEMS SUPPLIED

- Steel, galvanized
- With galvanized steel fastening material, for profile
- With leveling element
- Without dowels
- Weight = 20.347 kg/piece

APPLICATIONS

- Precise alignment of heavy constructions with cross-section 90x180 as post profile

ASSEMBLY

- Fasten footplate to the floor using a high performance anchor
- Fasten profile plate to the profile with supplied hardware
- Adjust height by turning screw M30 and secure with counter nut.

FLOOR MOUNTING ANGLE

Part no.

21.1112/0

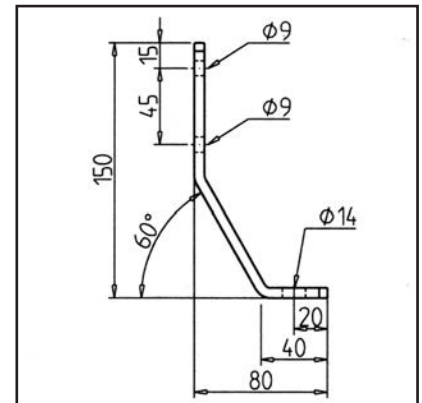
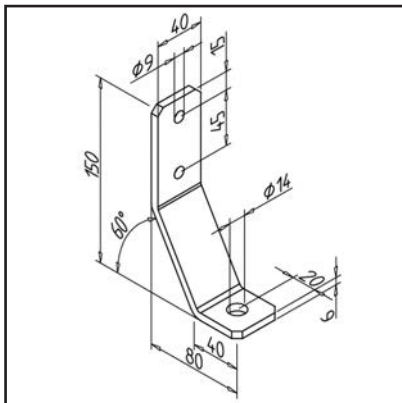

TECHN. DATA / ITEMS SUPPLIED

- Steel, powder-coated, grey
- With fastening material steel, zinc plated
- Without dowels
- Weight = 0.389 kg/piece

APPLICATIONS

- Securing and fastening of constructions on floor or wall

ASSEMBLY

- On profile side with cylinder screws M8 x 20, SW5
- Bottom side with high performance anchor 12 **part no. 21.1115/0**
- Also suitable for subsequent mounting

FLOOR MOUNTING ANGLE

Part no. 21.0015/0

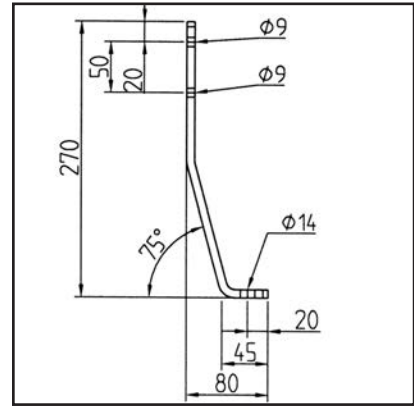
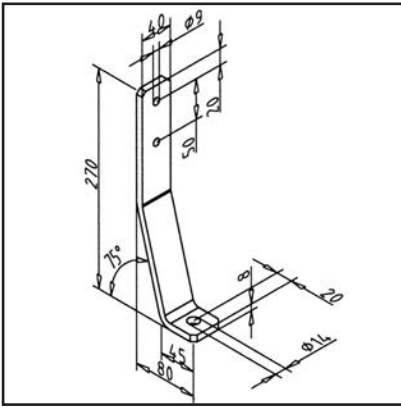

TECHN. DATA / ITEMS SUPPLIED

- Steel, powder-coated, grey
- With fastening material steel, zinc plated
- Without dowels
- Weight = 0.786 kg/piece

APPLICATIONS

- For securing heavy constructions under dynamic load on floor or wall

ASSEMBLY

- On the profile side with cylinder screw M8 x 20, SW 5
- Bottom side with high performance anchor 12 **part no. 21.1115/0**
- Also suitable for subsequent mounting

STRUT SOCKET 45 GD

Part no. 21.1729/0

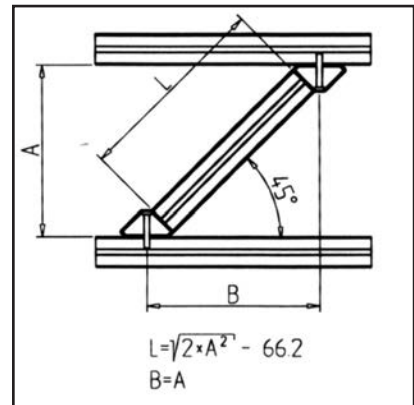
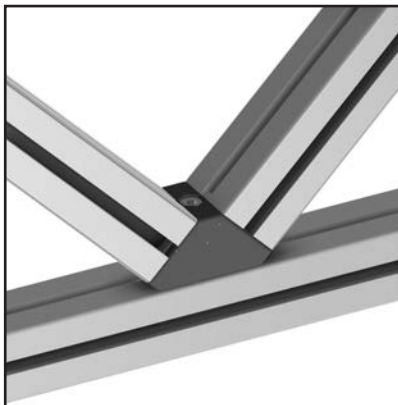
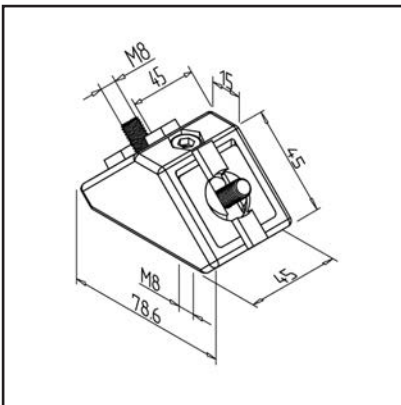

TECHN. DATA / ITEMS SUPPLIED

- Aluminium, Pressure die-casting, powder-coated, grey
- With fastening material steel, zinc plated
- Use on vertical struts **part no. 21.1729/7** (square nut with position-fixing)
- Weight = 0.261 kg/piece

APPLICATIONS

- Bracing in the composite structure

ASSEMBLY

- Pre-assemble brace base and place in frame
- Screw the brace socket onto the frame

STRUT SOCKET 45°/90

Part no.

21.1727/0

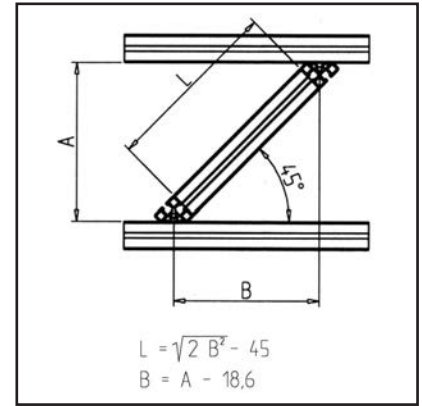
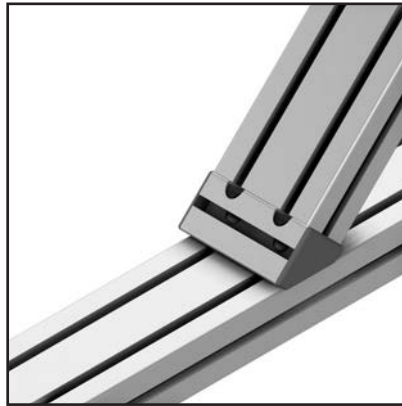
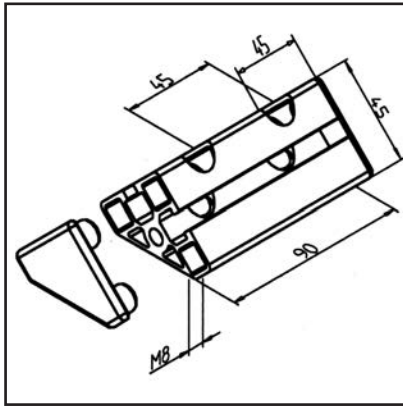

TECHN. DATA / ITEMS SUPPLIED

- Aluminium, anodized E6/EV1
- From profile 45/45°
- With fastening material steel, zinc plated
- With caps, grey
- Use on vertical struts **part no. 21.1727/4** (square nut with position-fixing)
- Weight = 0.175 kg/piece

APPLICATIONS

- Bracing in the composite structure

ASSEMBLY

- Screw the brace socket onto the frame
- Insert supports by means of MiniTec power-lock fasteners and tighten
- Install caps

CONNECTING PLATE 60 X 60 X 30

Part no.

21.0038/0

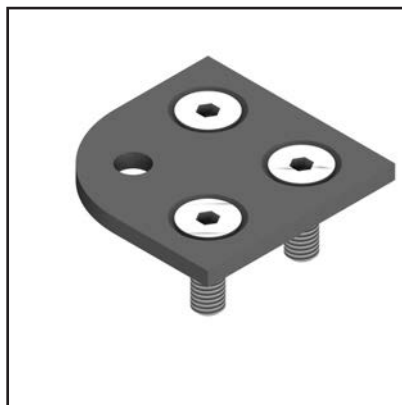
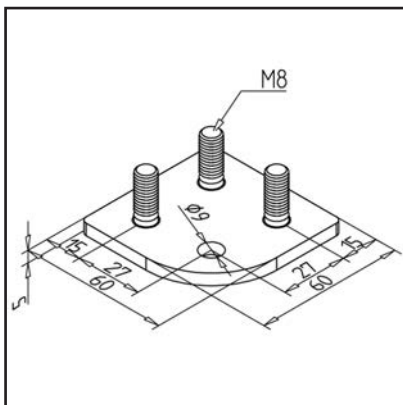

TECHN. DATA / ITEMS SUPPLIED

- Steel, powder-coated, grey
- With fastening nut steel, galvanized
- Fastening kit
- Weight = 0.145 kg/piece

APPLICATIONS

- Profile 60 x 60 x 30 **part no. 20.0982/0**
- For the construction of guide rollers
- Use of hinged foot M8

ASSEMBLY

- Front attachment to profile with supplied hardware
- Fasten to profile with fastening material from the scope of delivery

BASE AND TRANSPORT PLATE 90 X 90 X 45

Part no.

21.2505/0

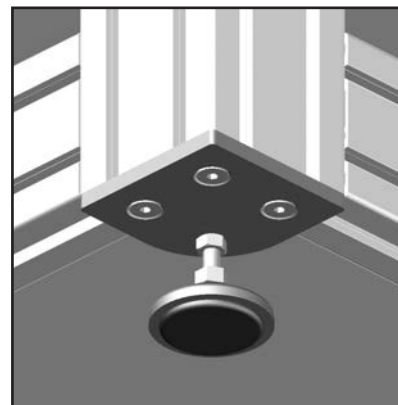
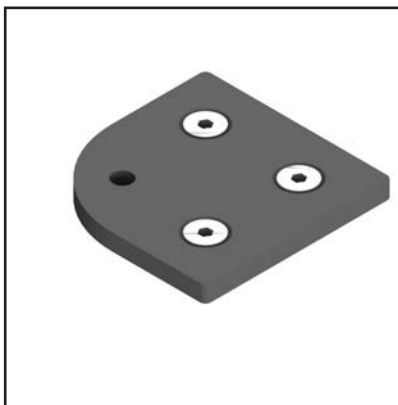
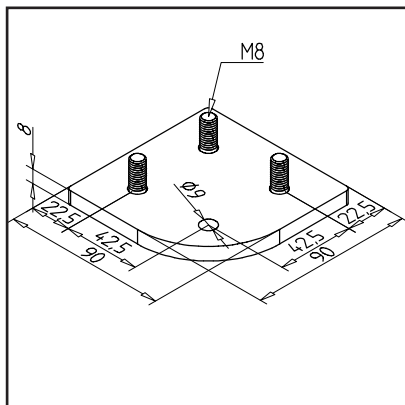

TECHN. DATA / ITEMS SUPPLIED

- Steel, powder-coated, grey
- With fastening material steel, zinc plated
- Weight = 0.488 kg/piece

APPLICATIONS

- Use of hinged foot M8
- For the construction of guide rollers
- To profile 90 x 90 x 45 **part no. 20.0984/0**

ASSEMBLY

- Front attachment to profile with supplied hardware

ADAPTER FLANGE 30

Part no.

21.2120/0

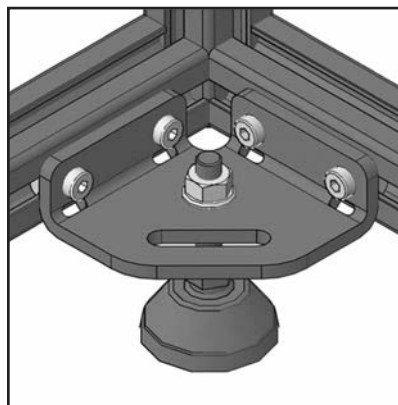
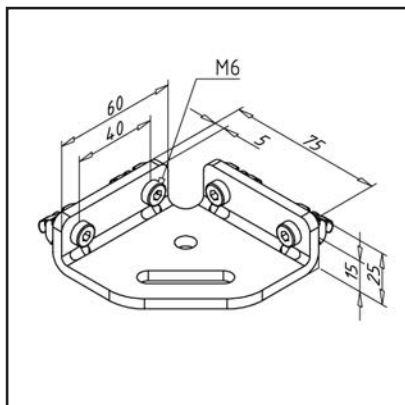

TECHN. DATA / ITEMS SUPPLIED

- Steel, powder-coated, grey
- With fastening material steel, zinc plated
- Weight = 0.261 kg/piece

APPLICATIONS

- Strengthening of profile constructions
- Fixation of internal feet or rollers
- Floor mounting and leveling constructions

ASSEMBLY

- Mount onto frame with fixation material from delivery scope

ADAPTER FLANGE 45

Part no.

21.2300/0

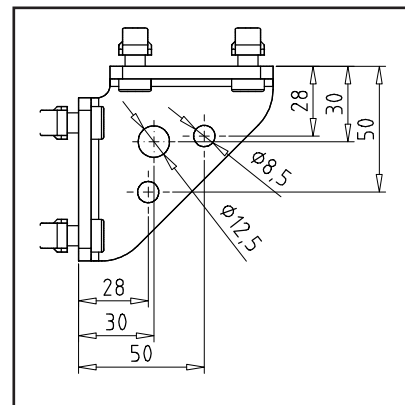
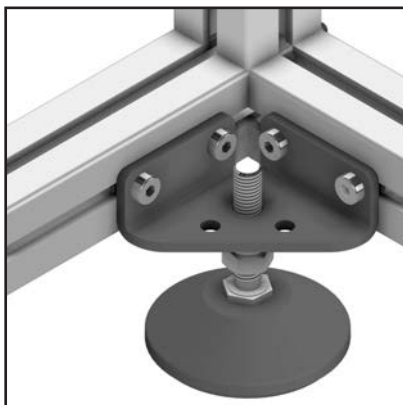
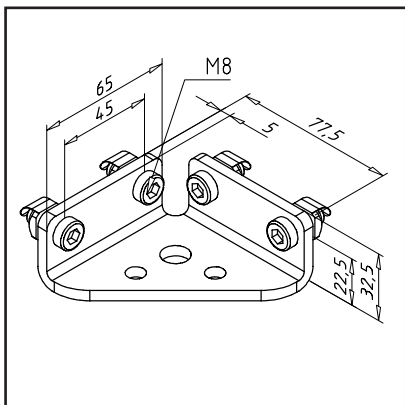

TECHN. DATA / ITEMS SUPPLIED

- Steel, powder-coated, grey
- With fastening material steel, zinc plated
- Weight = 0.311 kg/piece

APPLICATIONS

- Strengthening of profile constructions
- Fixation of internal feet or rollers
- Floor mounting and leveling constructions

ASSEMBLY

- Mount onto frame with fixation material from delivery scope

BEAM 90

Part no.

21.1783/0

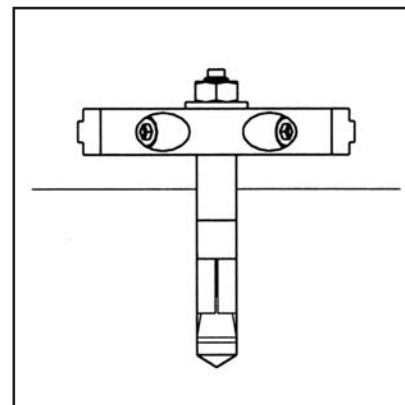
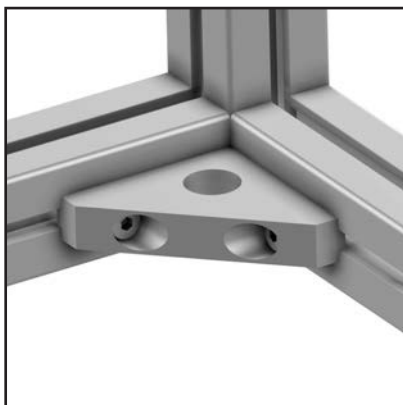
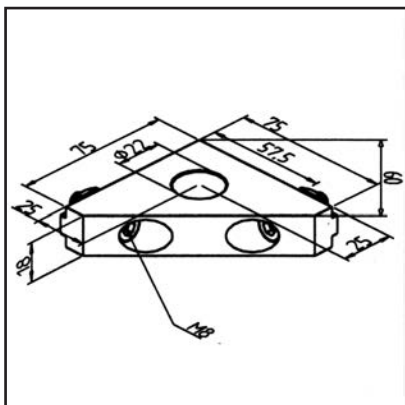

TECHN. DATA / ITEMS SUPPLIED

- Aluminium, anodized E6/EV1
- With fastening material steel, zinc plated
- Use on vertical struts **part no. 21.1783/7**
- Weight = 0.170 kg/piece

APPLICATIONS

- Strengthening of constructions
- Fixation of internal feet or rollers
- Floor mounting and leveling constructions

ASSEMBLY

- On profile side, with fastening kit
- On floor side, fasten with floor anchor

BEAM 180

Part no.

21.1784/0

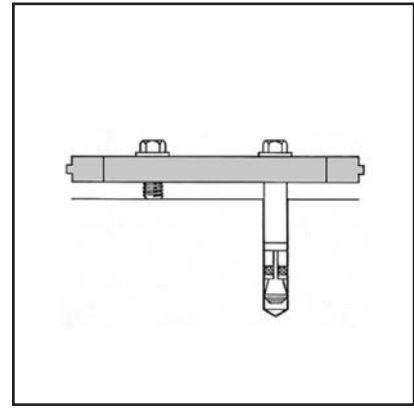
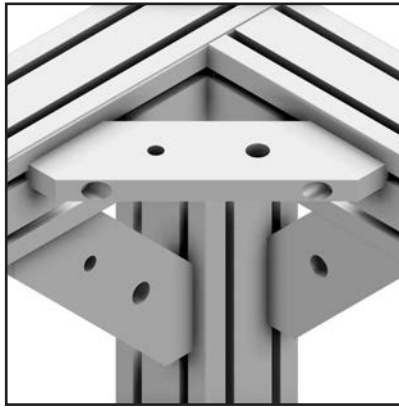
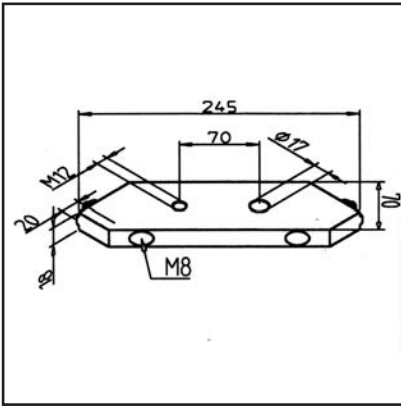

TECHN. DATA / ITEMS SUPPLIED

- Aluminium, anodized E6/EV1
- With fastening material steel, zinc plated
- Use on vertical struts **part no. 21.1784/7**
- Weight = 0.690 kg/piece

APPLICATIONS

- Strengthening of heavy constructions
- Fixation of internal feet or rollers
- Floor mounting and leveling heavy constructions

ASSEMBLY

- On profile side, with fastening kit
- On floor side, fasten with floor anchor and levelling screw M 12

STRENGTHENING ELEMENT 30

Part no.

21.2110/0

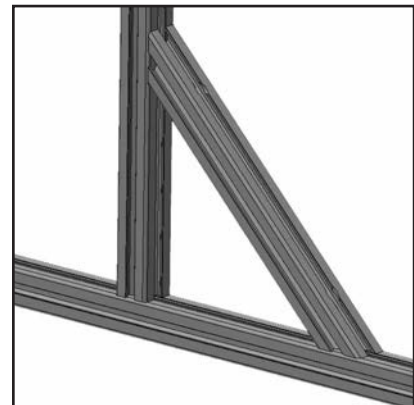
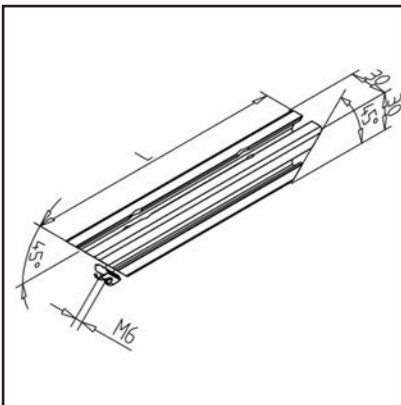

TECHN. DATA / ITEMS SUPPLIED

- Aluminium, anodized E6/EV1
- Length (l) : 360 mm
- Profile 30 x 30, ready for use
- Both ends cut at 45° with counter-bores for fastening kit
- With fastening material steel, zinc plated
- **Other lengths and designs under part no. 21.1761/5 on request**
- **Please specify dimension L**
- Weight = 0.212 kg/piece

APPLICATIONS

- Reinforcement of profile constructions in "timbered structure" principle

ASSEMBLY

- Screw on the profile groove of the frame construction with supplied hardware

STRENGTHENING ELEMENT 30 X 60

Part no.

21.2210/0

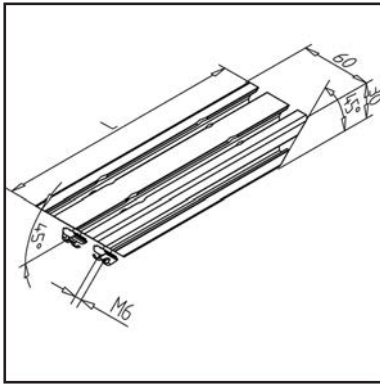
**TECHN. DATA / ITEMS SUPPLIED**

- Aluminium, anodized E6/EV1
- Length (l) : 360 mm
- Profile 30 x 60, ready for use
- Both ends cut at 45° with counter-bores for fastening kit
- With fastening material steel, zinc plated
- **Other lengths and designs under part no. 21.2210/5 on request**
- **Please specify dimension L**
- Weight = 0.338 kg/piece

**APPLICATIONS**

- Reinforcement of profile constructions in "timbered structure" principle

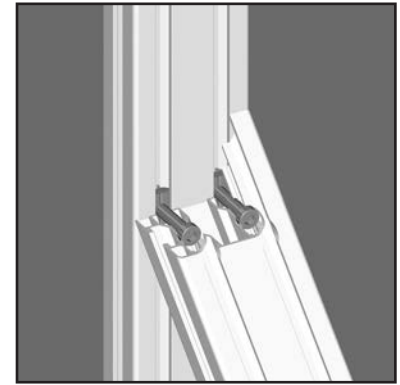
**ASSEMBLY**

- Screw on the profile groove of the frame construction with supplied hardware

STRENGTHENING ELEMENT 45

Part no.

21.1761/0

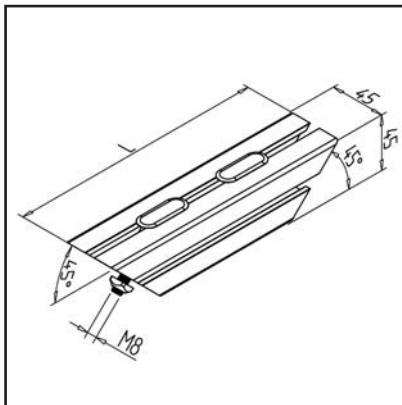
**TECHN. DATA / ITEMS SUPPLIED**

- Aluminium, anodized E6/EV1
- Length (l) : 360 mm
- Profile 45 x 45, ready for use
- Both ends cut at 45° with counter-bores for fastening kit
- With fastening material steel, zinc plated
- Use on vertical struts **part no. 21.1761/7** (square nut with position-fixing)
- **Other lengths and designs under part no. 21.1761/5 on request**
- **Please specify dimension L**
- Weight = 0.870 kg/piece

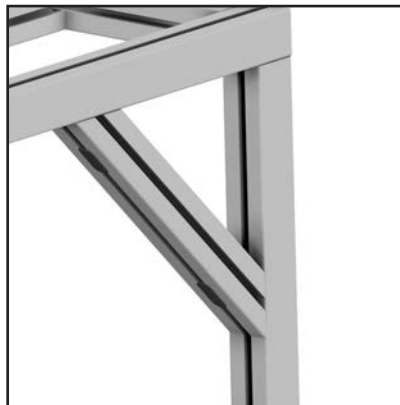
**APPLICATIONS**

- Reinforcement of profile constructions in "timbered structure" principle

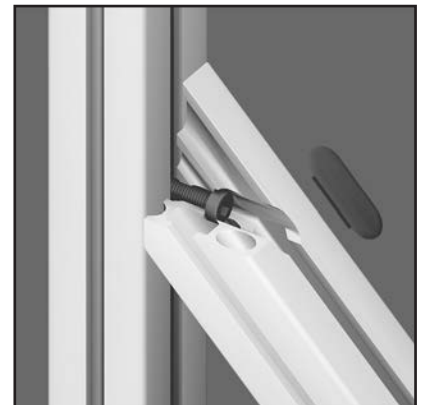
**ASSEMBLY**

- Screw on the profile groove of the frame construction with supplied hardware

STRENGTHENING ELEMENT 45 VA

Part no.

21.1706/0

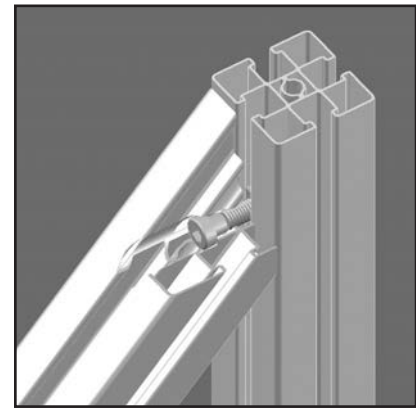
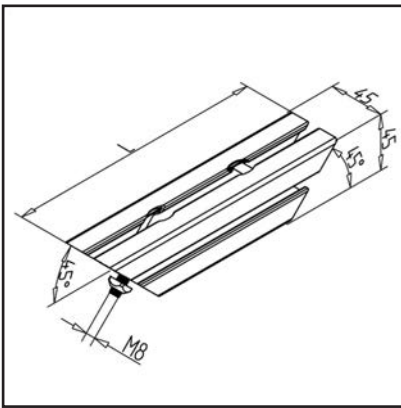

TECHN. DATA / ITEMS SUPPLIED

- Stainless steel
- Length (l) : 360 mm
- Profile 45x45 VA, ready for installation
- Both ends cut at 45° with counter-bores for fastening kit
- Fastening kit
- **Other lengths on request**
- **Please specify dimension L**
- Weight = 0.890 kg/piece

APPLICATIONS

- Reinforcement of profile constructions in "timbered structure" principle

ASSEMBLY

- Screw on the profile groove of the frame construction with supplied hardware

STRENGTHENING ELEMENT 90

Part no.

21.1762/0

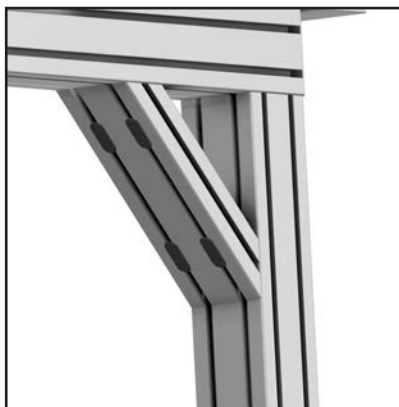
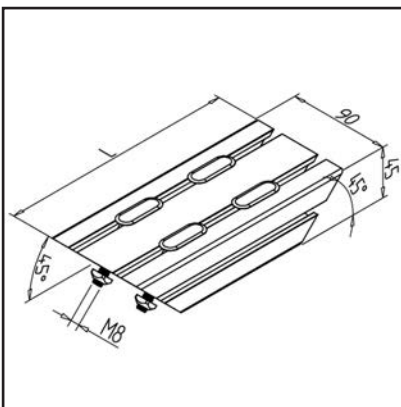

TECHN. DATA / ITEMS SUPPLIED

- Aluminium, anodized E6/EV1
- Length (l) : 360 mm
- Profile 45 x 90, ready for use
- Both ends cut at 45° with 4 counter-bores for fastening kit
- With fastening material steel, zinc plated
- **Other lengths and designs under part no. 21.1762/5 on request**
- **Please specify dimension L**
- Weight = 1.416 kg/piece

APPLICATIONS

- Reinforcement of profile constructions in "timbered structure" principle

ASSEMBLY

- Screw on the profile groove of the frame construction with supplied hardware

CANTILEVER FOOT 175

Part no.

21.2191/0

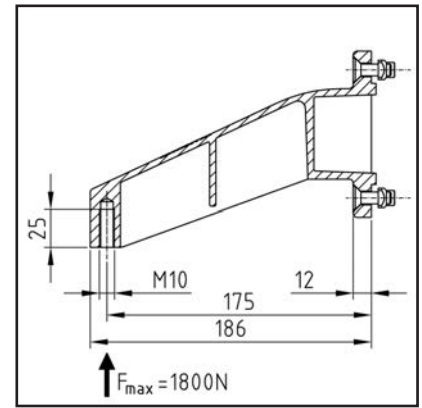
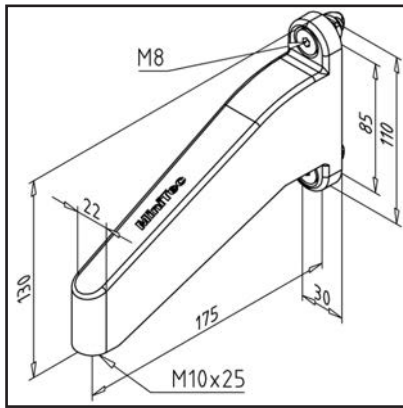

TECHN. DATA / ITEMS SUPPLIED

- Aluminium, Pressure die-casting, powder-coated, grey
- With fastening material steel, zinc plated
- Weight = 0.369 kg/piece

APPLICATIONS

- Placing frames and attaching stands

ASSEMBLY

- Attachment to profile strut with fastening material
- Fastening of casters, articulated feet, and screws M10

SUPPORTING FOOT 45 GD

Part no.

21.1731/0

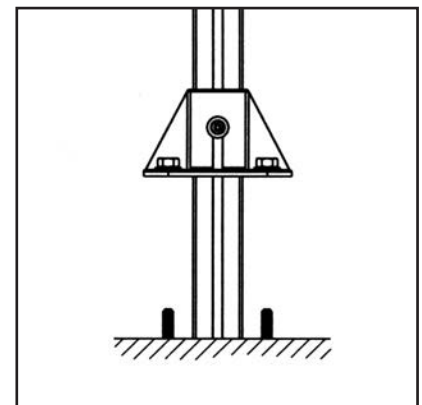
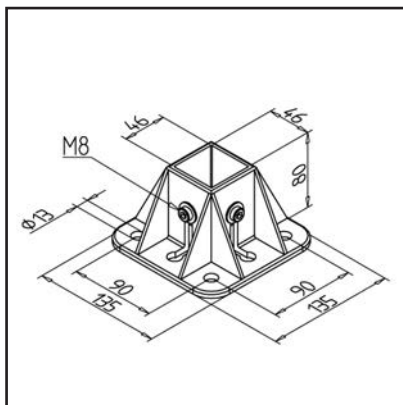

TECHN. DATA / ITEMS SUPPLIED

- Aluminium, Pressure die-casting, powder-coated, grey
- With galvanized steel fastening material, for profile
- Package size of 10 pieces **part no. 21.1731/010**
- Weight = 0.587 kg/piece

APPLICATIONS

- Suitable for profiles up to dimension 45 x 45
- Floor fastening of protective fields, sign-boards, racks
- As connection element for wall attachment; can be used both-sided

ASSEMBLY

- Insert profile into foot
- Insert the square nut with spring steel sheet into the profile groove; preassemble the screws
- Fix the floor stand to the floor or wall, using the high-performance anchors or the universal pin with a hexagonal screw
- Tighten fastening screws

COVER SUPPORTING FOOT 45

Part no. 22.1164/0

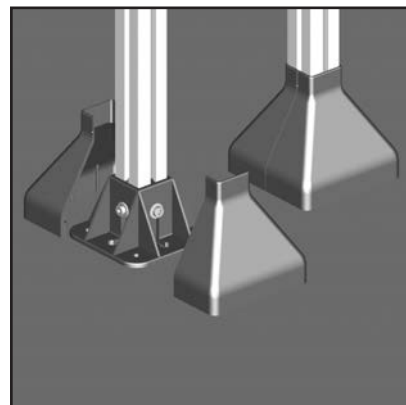
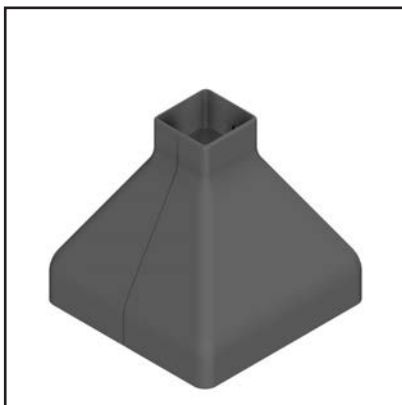
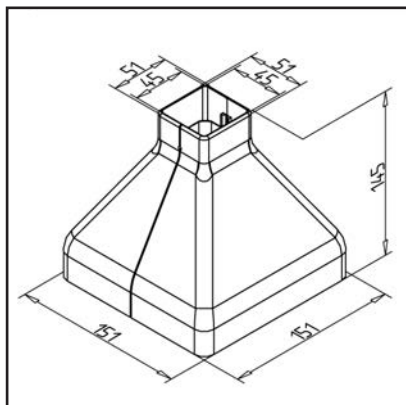

TECHN. DATA / ITEMS SUPPLIED

- ABS, grey
- Weight = 0.166 kg/pair

APPLICATIONS

- To cover the stand foot 45 GD and 45 GD open

ASSEMBLY

- Attach to profiles/stand foot

SUPPORTING FOOT 45 GD OPEN

Part no. 21.1738/0

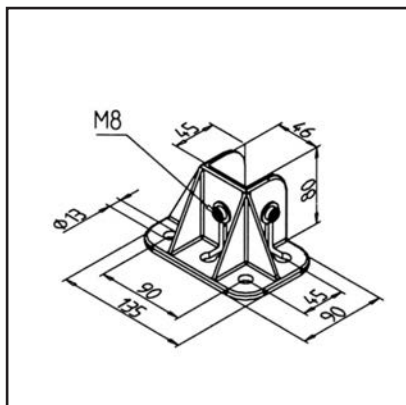

TECHN. DATA / ITEMS SUPPLIED

- Aluminium, Pressure die-casting, powder-coated, grey
- With galvanized steel fastening material, for profile
- Package size of 10 pieces **part no.. 21.1738/010**
- Weight = 0.356 kg/piece

APPLICATIONS

- Floor fastening of protective fields, signboards, racks
- As connection element for wall attachment; can be used both-sided

ASSEMBLY

- Insert profile into foot
- Insert the square nut with spring steel sheet into the profile groove; preassemble the screws
- Fix the floor stand to the floor or wall, using the high-performance anchors or the universal pin with a hexagonal screw
- Tighten fastening screws

SUPPORTING FOOT 45 GD S

Part no.

21.1723/0

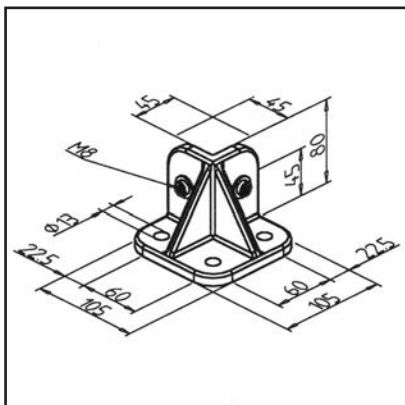

TECHN. DATA / ITEMS SUPPLIED

- Aluminium, Pressure die-casting, powder-coated, grey
- With galvanized steel fastening material, for profile
- Package size of 10 pieces **part no.. 21.1723/010**
- Weight = 0.499 kg/piece

APPLICATIONS

- Floor fastening of protective fields, sign-boards, racks
- As connection element for wall attachment; can be used both-sided
- For all profiles

ASSEMBLY

- Fix the floor stand to the floor or wall, using the high-performance anchors or the universal pin with a hexagonal screw
- Tighten fastening screws

SUPPORTING FOOT 90 GD

Part no.

21.1737/0

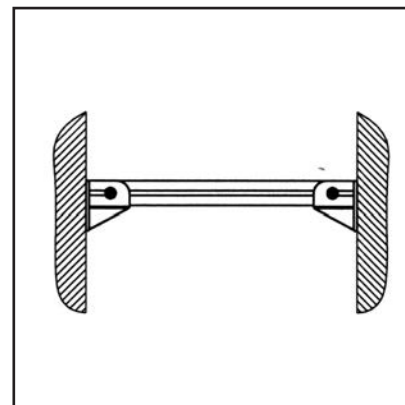
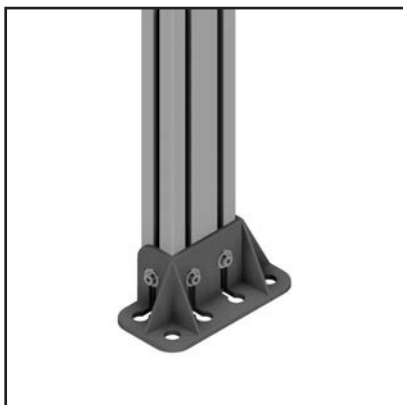
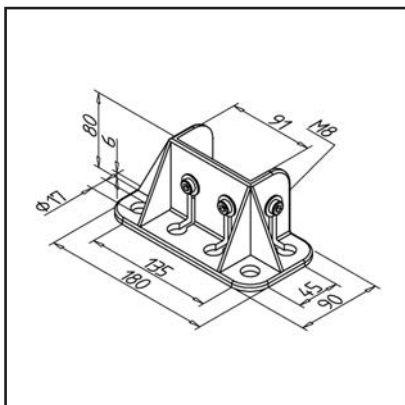

TECHN. DATA / ITEMS SUPPLIED

- Aluminium, Pressure die-casting, powder-coated, grey
- With galvanized steel fastening material, for profile
- Package size of 10 pieces **part no.. 21.1737/010**
- Weight = 0.465 kg/piece

APPLICATIONS

- Fitting for profiles with maximum dimension of 45 x 90, 90 x 90 and 90 x 180
- Floor fastening of protective fields, sign-boards, racks
- As connection element for wall attachment; can be used both-sided

ASSEMBLY

- Insert profile into foot
- Insert the square nut with spring steel sheet into the profile groove; preassemble the screws
- Fix the floor stand to the floor or wall, using the high-performance anchors or the universal pin with a hexagonal screw
- Tighten fastening screws

TRANSPORT AID

Part no.

26.1101/0

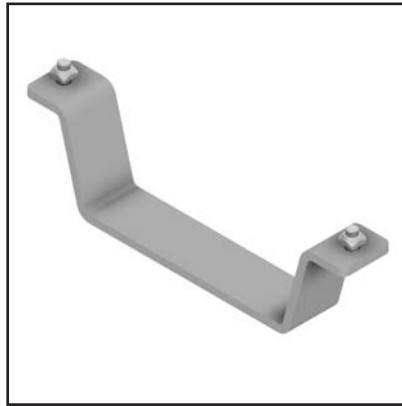
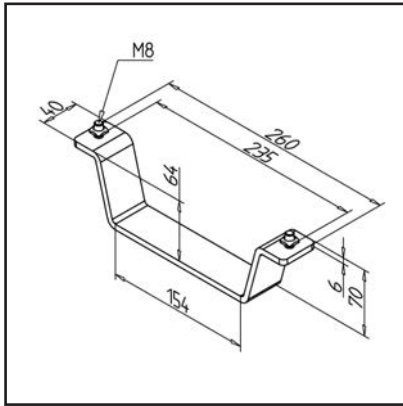
**TECHN. DATA / ITEMS SUPPLIED**

- Steel, galvanized
- With fastening material steel, zinc plated
- Weight = 0.708 kg/piece

APPLICATIONS

- Securing of constructions when transported by forklift truck

ASSEMBLY

- Mount under construction with fastening material from the scope of supply to the profile groove
- Use always in pairs

INSTALLATION OF SURFACE ELEMENTS

INSTALLING SURFACE ELEMENTS IN THE PROFILE GROOVE

Basically, a distinction must be made between installation in the profile groove and subsequent fastening of surface elements. For installation in the profile groove, the installation procedure must be planned accordingly. It is recommended to create complete protective fields which are inserted into a construction. This mounting method has particular advantages for large surfaces, when processing woven wire mesh and sealed constructions. The subsequent installation of panel elements is usually easier and the risk of damage is lower.

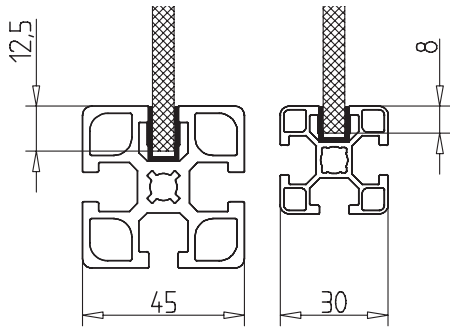

Clamp profile

Surface elements of 6 mm thickness can be combined with a clamp profile.

Install directly in the profile groove.

Allowance for surface elements in x and y direction for mounting in profile groove:

- 30er groove system +16 mm
- 45er groove system +25 mm

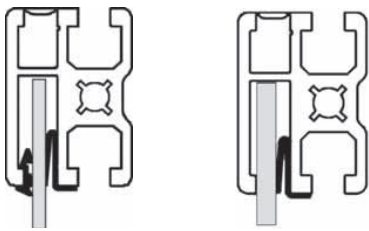

Clamping profile 45 x 32

The clamping profile 45 x 32 contains the properties of the system profiles and a safe, simple fastening of surface elements integrated.

This option is particularly recommended for large protective fields and wave grid constructions. The protective fields are prefabricated and can be easily installed with protective field suspensions in the frame of the construction. Quick removal of such protective fields is also possible.

Allowance for surface elements in x and y direction for mounting in profile groove:

- 1) Simple frame: +50 mm
- 2) Frame with one or more intermediate struts: +40 mm

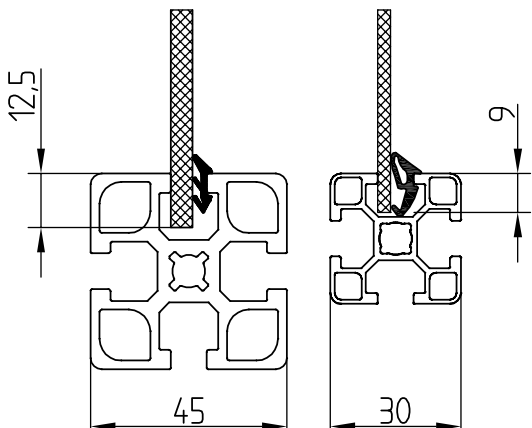
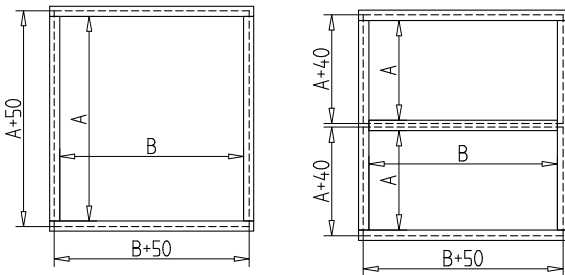

Plug seals

Panes of glass, PVC, composite material, acrylic or similar of 2 - 6 mm thickness can be filled with the plug-in seals 2, 4, 5 and 6 are secured and sealed in the profile. The plug-in seal is subsequently pressed into the gap between the disc and the profile groove flank. When using plug-in seal 4 on both sides, materials < 2 mm clamp.

Allowance for surface elements in x and y direction for mounting in profile groove:

- 30 groove system +18 mm with plug-in seal 30
- 45 groove system +25 mm with plug-in seal 2/4/5/6

INSTALLATION OF SURFACE ELEMENTS

INSTALLING SURFACE ELEMENTS IN THE PROFILE GROOVE

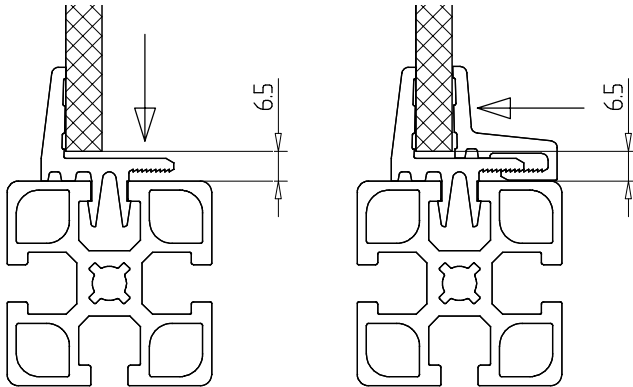
**Clamping profile PVC**

Optically appealing, simple and secure attachment of surface elements of all kinds, without circumferential gap between the construction profile and surface element.

Suitable for surface elements up to 8 mm thick, also for wavy grid.

Calculation of panel size: Clear opening - 13 mm

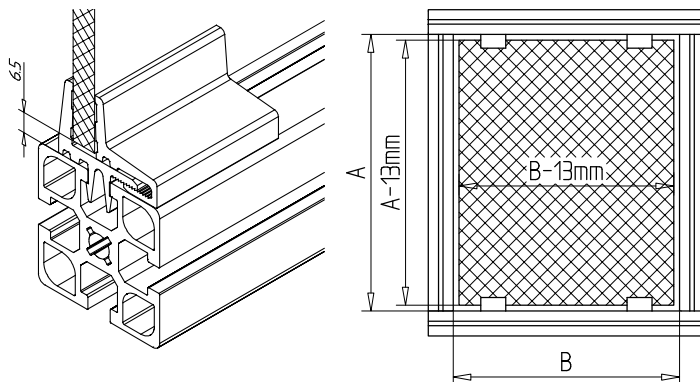
**Panel holder**

Extremely simple and cost-effective attachment of surface elements. The panel holders consist of 2 halves.

Suitable for all surface elements up to 8 mm thickness. For corrugated gratings, please use the PVC clamping profile at this point.

Calculation of panel size:

Clear opening - 13 mm (6.5 mm air circulating)

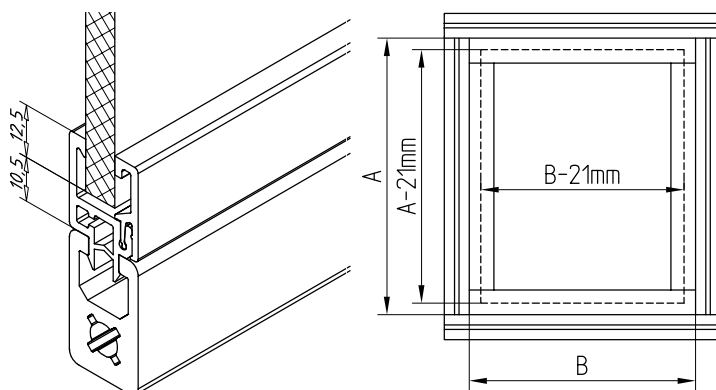
**Window Edging Profile**

Simple and economical installation of surface elements.

Also suitable for retrofitting into existing frames. No mitre cut required. Suitable for surface elements up to 8 mm thick. Dense attachment of panels < 8 mm with the plug-in gaskets.

For the subsequent installation of wave mesh, please use the PVC clamping profile.

INSTALLATION OF SURFACE ELEMENTS

INSTALLING SURFACE ELEMENTS IN THE PROFILE GROOVE

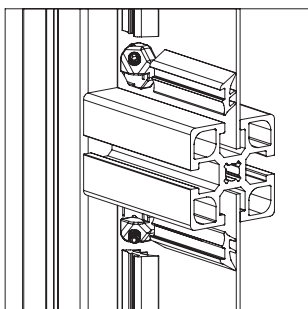

Earthing / conductive connection

For conductive connection of aluminum or steel sheets with the profile frame in the thickness of 1.5mm - 2.5mm please use our earthing block **part no. 22.1163/0**.

One surface block is sufficient per surface element. In connection with our insert seal 2, the sheet metal is fastened in the profile frame.

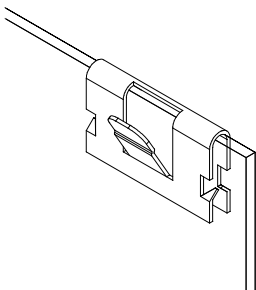

Earthing clamp **part no.: E9.0141/0**

For grounding sheet metal and thin-walled components with wall thickness of 0.7 - 2 mm

Especially suitable for:

Cable duct AL **part no. 20.1051/0**

Cable duct 45 AL **part no. 20.1071/0**

Cable duct 90 AL **part no. 20.1056/0**

- Attach to sheet metal edge
- Safe support and conductive connection is provided by claws
- For the connection of the earthing cable with 6 mm flat plug

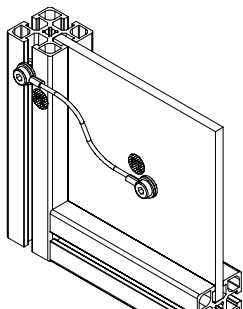

Earthing cable for ESD areas

Wire line green-yellow 4mm² Length: ca. 200 mm

Attach to profile groove with fixing material from scope of delivery.

With standard accessory for grounding of surface elements with 8 mm

part no. 32.1013/0

Attachment with eyelet on both sides for M8

part no. 32.1016/0

Attachment with eyelet on one side for M8, other side for M6

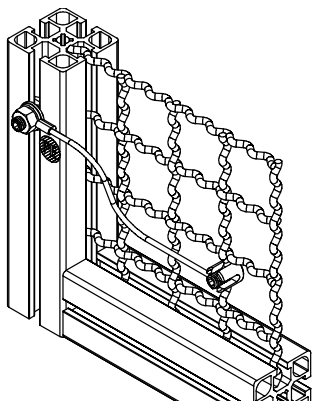

Earthing clamp wave grid **part no. E9.0143/0**

Wire line green-yellow 4mm² Length: ca. 200 mm

Attach to profile groove with fixing material from scope of delivery.

Attach grounding clip to wave grid, fasten and connect with eyelet.

INSTALLATION OF SURFACE ELEMENTS

INSTALLING SURFACE ELEMENTS IN THE PROFILE GROOVE

Panel clamp

Extremely simple and cost-effective fastening of panel elements. The terminal blocks consist of a base and locking clip. Suitable for all surface elements from 2 to 6 mm thick, except wavy grid.

Calculation of panel size:

Clear opening A / B - 12mm (6mm air circulating)

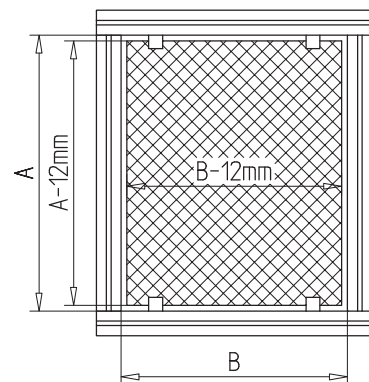
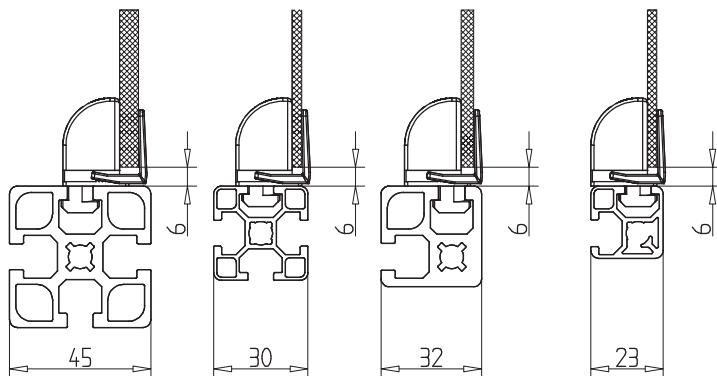
**Screw block**

Suitable for panel material up to 6 mm thick, except for wave grid.

Calculation of panel size:

Clear opening A / B - 6mm (3mm air circulating)

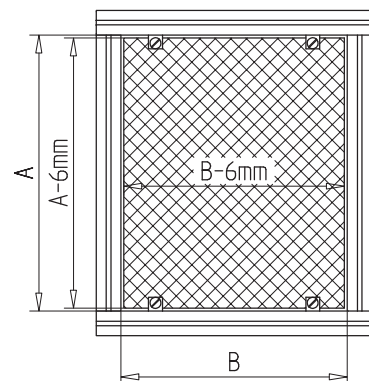
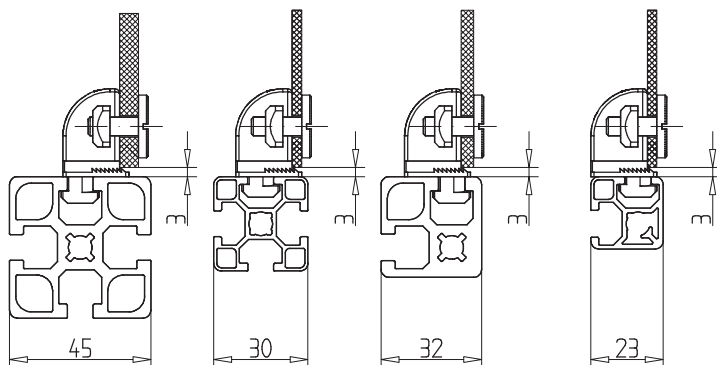

INSTALLATION OF SURFACE ELEMENTS

INSTALLING SURFACE ELEMENTS IN THE PROFILE GROOVE

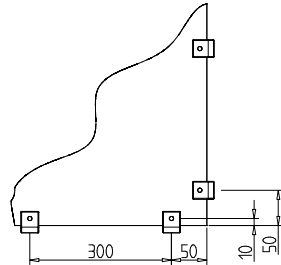
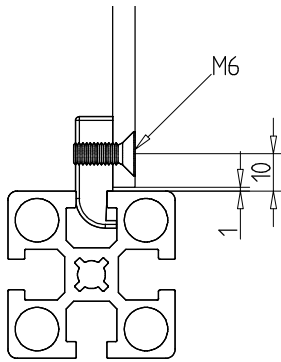

Thread Socket

Safe and easy attachment of surface elements of all kinds except wave grid. The threaded sockets are swiveled into the profile groove at intervals of approx. 300 mm. Select screw length and screw shape according to material thickness and type of surface element.

Calculation of panel size:

Clear opening -2 mm (1 mm air circulating)

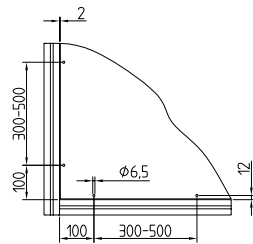
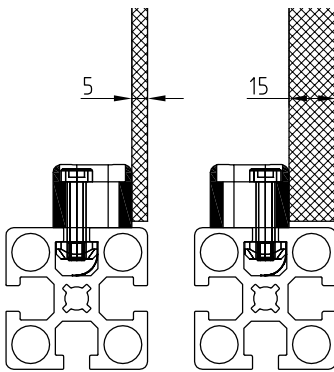

Multiblock

The multiblocks are placed in the clear opening of the frame construction at a distance of approx. 300 mm with M6 cylinder screws and sliding nuts.

Suitable for acrylic, sheet metal, aluminum wave grid.

With the Multiblock 45, material of 5 to 15 mm thickness can be fastened flush.

With the Multiblock 30, material up to 7.5 mm thick can be fastened flush. Select screw length and screw shape according to material thickness and type of surface element.

The hole in the surface element for the fixing screws is $\varnothing 6.5$ mm and with 10 mm margin.

Calculation of panel size:

Clear opening -4 mm (~ 2 mm air circulating)

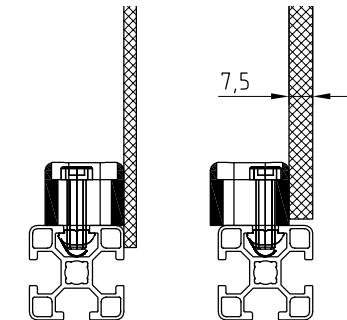

Furthermore, it is possible to mount surface elements on the Multiblock 30, so there is no air gap.



Screw Bar

Material: PVC

Fixing of surface elements or components at any place with sheet metal- or chipboard screws.

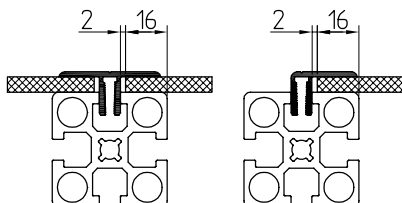

Panel Clamping Profile

Suitable for surface elements from 2 to 10 mm thick. Insert boring $\varnothing 5.5$ mm for M5 threaded pin with a spacing of ~ 250 mm into the profile groove and clamp with M5 x 16 threaded pin.

For panels, woven wire mesh and pressed wire mesh

CLAMPING BLOCK 23

Part no.

22.1235/0

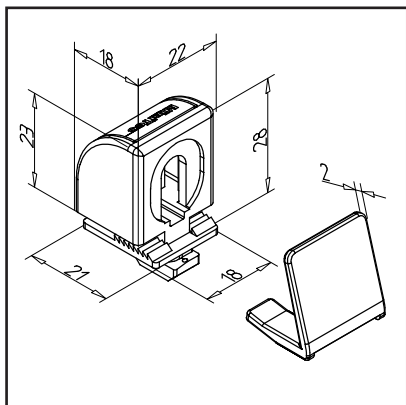
**TECHN. DATA / ITEMS SUPPLIED**

- ABS, Injection Mould, grey
- Weight = 0.008 kg/piece

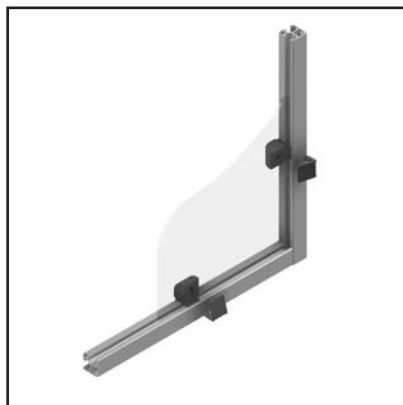
**APPLICATIONS**

- Suitable for all profiles of series 30
- Retrofitting surface elements 2 mm to 6 mm thickness
- Circulating air gap 6 mm

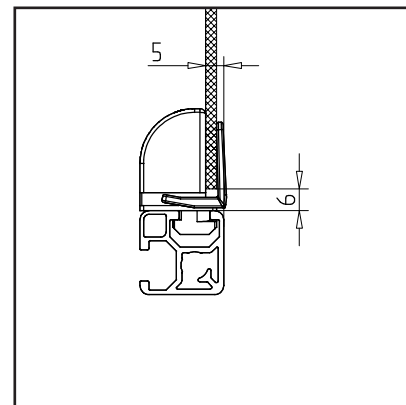
**ASSEMBLY**

- Insert socket into profile groove
- Insert surface elements
- Press on clip
- **Dismounting:** Lift snap-in clip slightly and pull it out

CLAMPING BLOCK 30

Part no.

22.1230/0

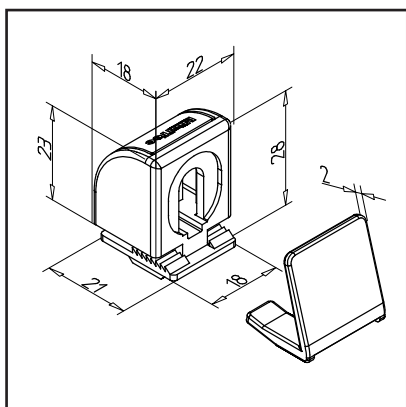
**TECHN. DATA / ITEMS SUPPLIED**

- ABS, Injection Mould, grey
- Weight = 0.008 kg/piece

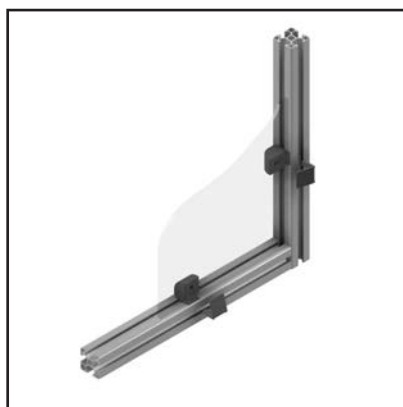
**APPLICATIONS**

- Suitable for all profiles of series 30
- Retrofitting surface elements 2 mm to 6 mm thickness
- Circulating air gap 6 mm

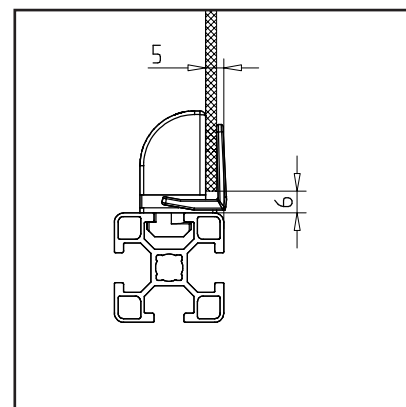
**ASSEMBLY**

- Insert socket into profile groove
- Insert surface elements
- Press on clip
- **Dismounting:** Lift snap-in clip slightly and pull it out

CLAMPING BLOCK 32

Part no.

22.1245/0

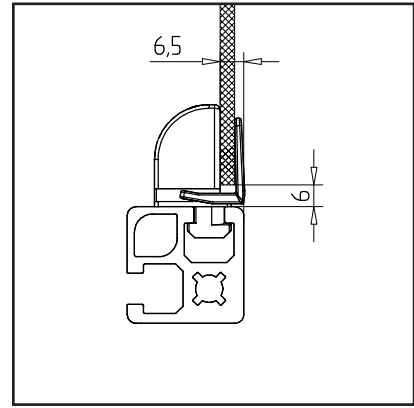
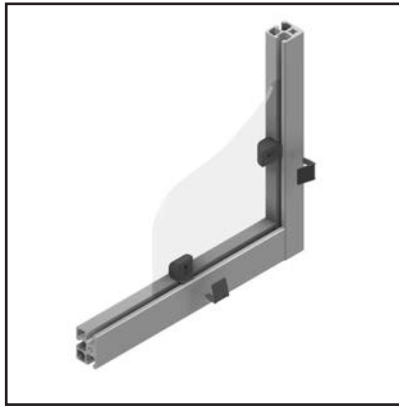
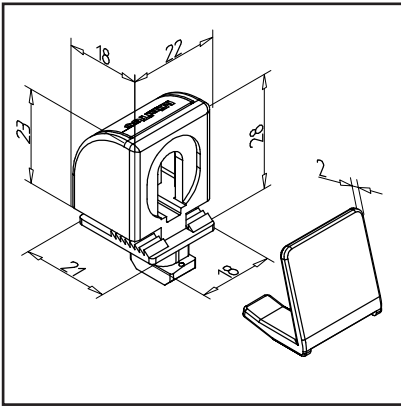

TECHN. DATA / ITEMS SUPPLIED

- ABS, Injection Mould, grey
- Weight = 0.008 kg/piece

APPLICATIONS

- Suitable for profile series 45
- Retrofitting surface elements 2 mm to 6 mm thickness
- Circulating air gap 6 mm

ASSEMBLY

- Insert socket into profile groove
- Insert surface elements
- Press on clip
- **Dismounting:** Lift snap-in clip slightly and pull it out

CLAMPING BLOCK 45

Part no.

22.1240/0

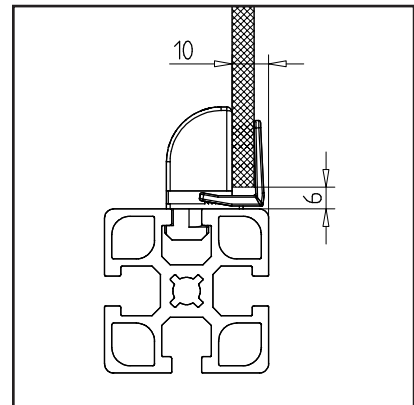
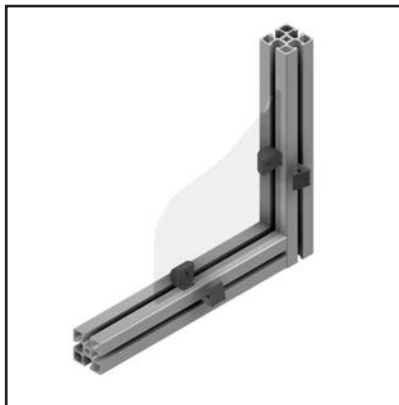
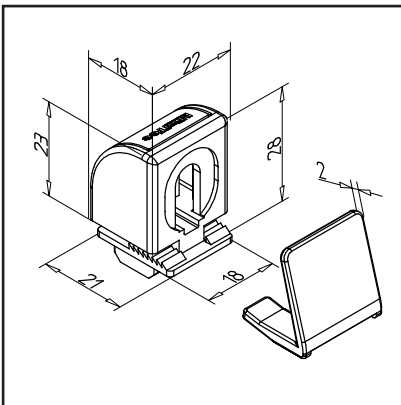

TECHN. DATA / ITEMS SUPPLIED

- ABS, Injection Mould, grey
- Weight = 0.008 kg/piece

APPLICATIONS

- Suitable for profile series 45
- Retrofitting surface elements 2 mm to 6 mm thickness
- Circulating air gap 6 mm

ASSEMBLY

- Insert socket into profile groove
- Insert surface elements
- Press on clip
- **Dismounting:** Lift snap-in clip slightly and pull it out

SCREW BLOCK 23

Part no.

22.1255/0

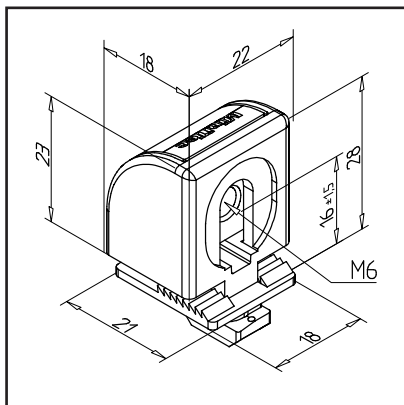

TECHN. DATA / ITEMS SUPPLIED

- ABS, Injection Mould, grey
- Nut M6, steel, zinc-plated
- Also available with thread dimensions M4/M5/M8
- Weight = 0.011 kg/piece

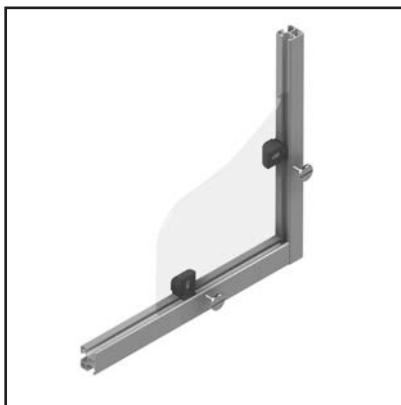

APPLICATIONS

- Suitable for all profiles of series 30
- Retrofitting surface elements 2 mm to 6 mm thickness
- Circulating air gap 7 mm

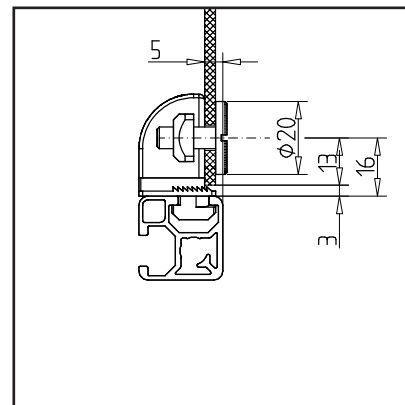

ASSEMBLY

- Insert socket into profile groove
- Insert bored surface elements
- Screw down the surface elements
- Recommended flat head screw M6x12 **part no. 21.2074/0** up to 3 mm disc thickness or M6x16 **part no. 21.1246/0** for greater strengths

SCREW BLOCK 30

Part no.

22.1250/0

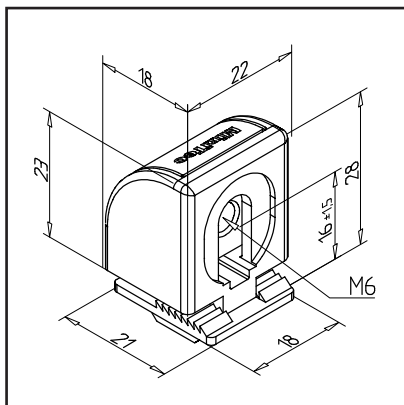

TECHN. DATA / ITEMS SUPPLIED

- ABS, Injection Mould, grey
- Nut M6, steel, zinc-plated
- Also available with thread dimensions M4/M5/M8
- Weight = 0.011 kg/piece

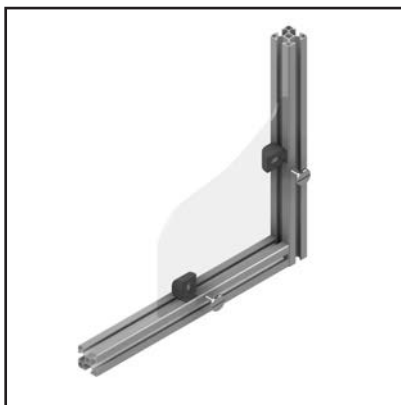

APPLICATIONS

- Suitable for all profiles of series 30
- Retrofitting surface elements 2 mm to 6 mm thickness
- Circulating air gap 7 mm

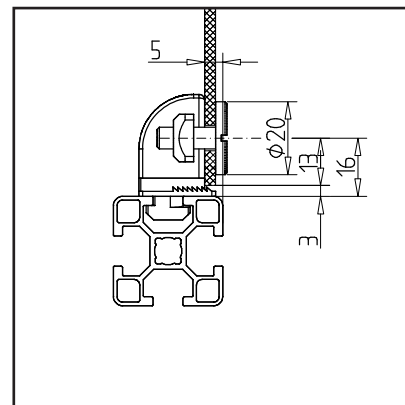

ASSEMBLY

- Insert socket into profile groove
- Insert bored surface elements
- Screw down the surface elements
- Recommended flat head screw M6x12 **part no. 21.2074/0** up to 3 mm disc thickness or M6x16 **part no. 21.1246/0** for greater strengths

SCREW BLOCK 32

Part no. 22.1265/0

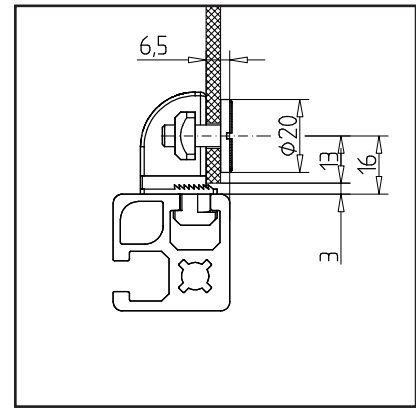
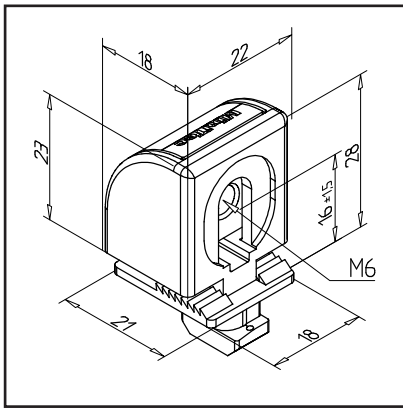

TECHN. DATA / ITEMS SUPPLIED

- ABS, Injection Mould, grey
- Nut M6, steel, zinc-plated
- Also available with thread dimensions M4/M5/M8
- Weight = 0.011 kg/piece

APPLICATIONS

- Suitable for profile series 45
- Retrofitting surface elements 2 mm to 6 mm thickness
- Circulating air gap 7 mm

ASSEMBLY

- Insert socket into profile groove
- Insert bored surface elements
- Screw down the surface elements
- Recommended flat head screw M6x12 **part no. 21.2074/0** up to 3 mm disc thickness or M6x16 **part no. 21.1246/0** for greater strengths

SCREW BLOCK 45

Part no. 22.1260/0

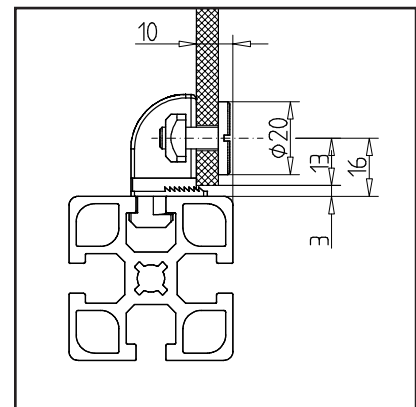
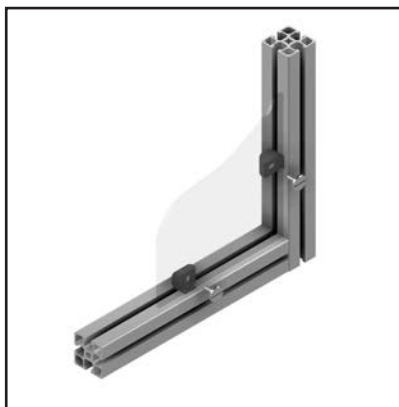
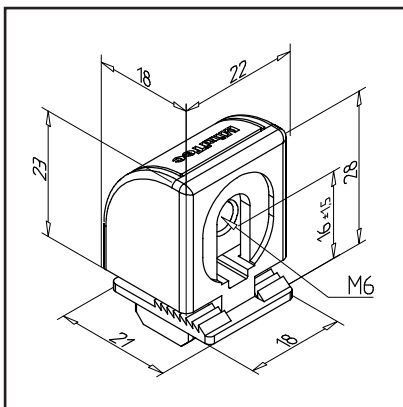

TECHN. DATA / ITEMS SUPPLIED

- ABS, Injection Mould, grey
- Nut M6, steel, zinc-plated
- Also available with thread dimensions M4/M5/M8
- Weight = 0.011 kg/piece

APPLICATIONS

- Suitable for profile series 45
- Retrofitting surface elements 2 mm to 6 mm thickness
- Circulating air gap 7 mm

ASSEMBLY

- Insert socket into profile groove
- Insert bored surface elements
- Screw down the surface elements
- Recommended flat head screw M6x12 **part no. 21.2074/0** up to 3 mm disc thickness or M6x16 **part no. 21.1246/0** for greater strengths

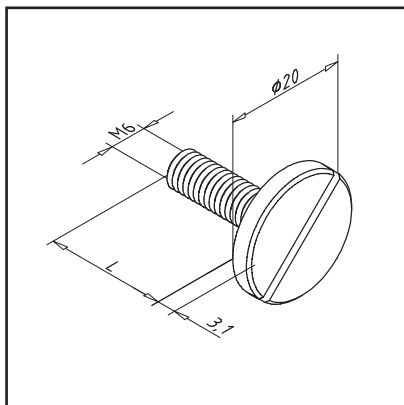
PAN HEAD SCREW M6**TECHN. DATA / ITEMS SUPPLIED**

- Steel, galvanized
- Head diameter $\phi 20$ mm
- M06x12 - **part no. 21.2074/0**, Weight 0,008 kg
- M06x16 - **part no. 21.1246/0**, Weight 0,009 kg
- M06x20 - **part no. 21.1246/1**, Weight 0,010 kg

**APPLICATIONS**

- Assembly of surface elements directly on profile groove
- In connection with screw blocks, multiblocks and thread socket

Part no.

--..../-

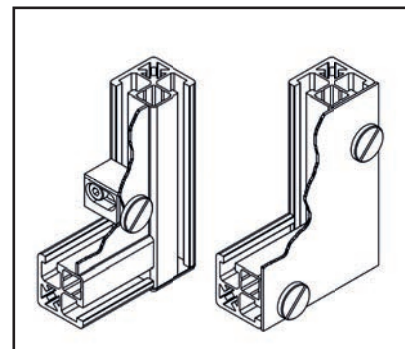
**ASSEMBLY**

- Pre-drill surface elements: $\phi 6.5$ mm
- Recommended grid dimensions: approx. 150 mm
- Edge distance: see screw block 32 and multi-block

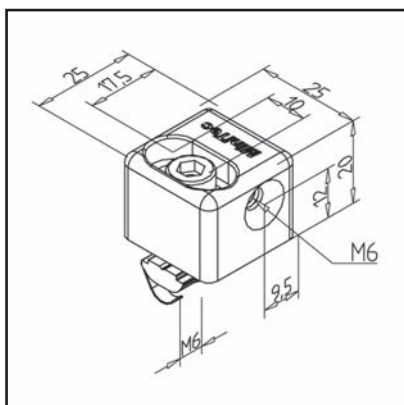
MULTIBLOCK 30 GD**TECHN. DATA / ITEMS SUPPLIED**

- Aluminium, Pressure die-casting, powder-coated, grey
- With fastening material steel, zinc plated
- Without pan head screw
- Weight = 0.032 kg/piece

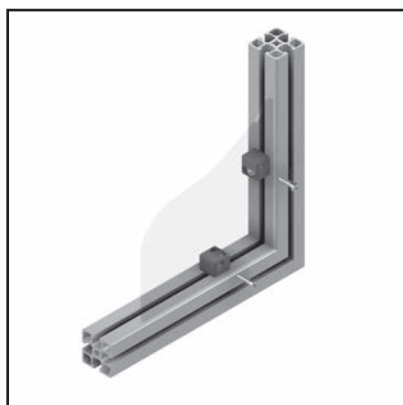
**APPLICATIONS**

- Retrofitting surface elements and attachments
- Plate thickness of 6 to 7 mm can be continuously flush fit
- Alternatively, surface elements can also be mounted on-the-floor, so they can also be installed without an air gap.

Part no.

21.2220/0

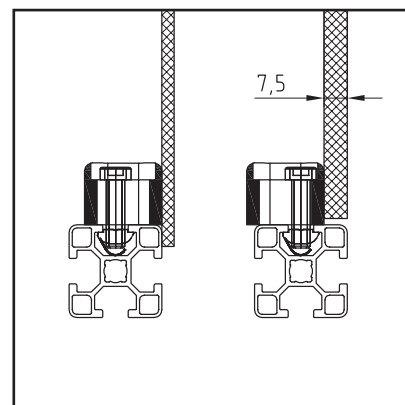
**ASSEMBLY**

- Fastening surface elements or components with screw M6 or flat head screw
- Determination of panel dimensions: Light opening -4mm (~2 mm circulating air)
- Bore for fixation screws $\phi 6.5$ mm, edge distance 10 mm

MULTIBLOCK GD

Part no.

21.1355/0

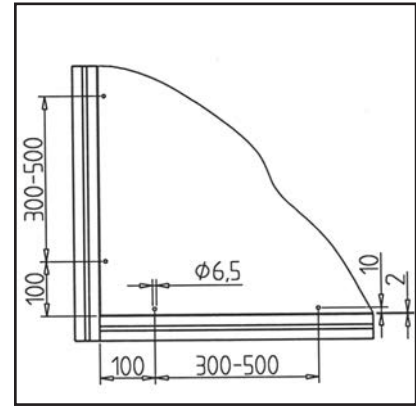
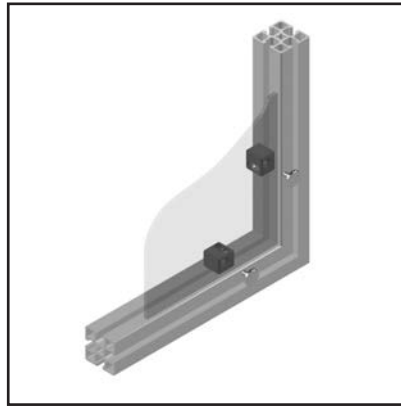
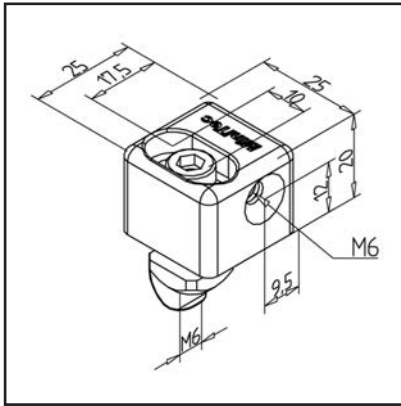

TECHN. DATA / ITEMS SUPPLIED

- Aluminium, Pressure die-casting, powder-coated, grey
- With fastening material steel, zinc plated
- Without pan head screw
- Use on vertical struts **part no. 21.1355/6** (square nut with position-fixing)
- Weight = 0.035 kg/piece

APPLICATIONS

- Retrofitting surface elements and attachments
- Plate thickness of 5 to 15 mm can be continuously flush fit

ASSEMBLY

- For all profile grooves
- Fastening surface elements or components with screw M6 or flat head screw
- Bore for fixation screws $\phi 6.5$ mm, edge distance 10 mm

THREAD SOCKET GD

Part no.

21.1117/1

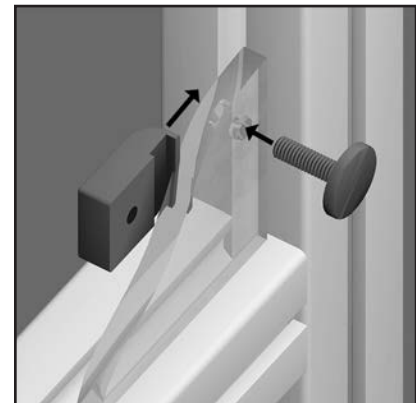
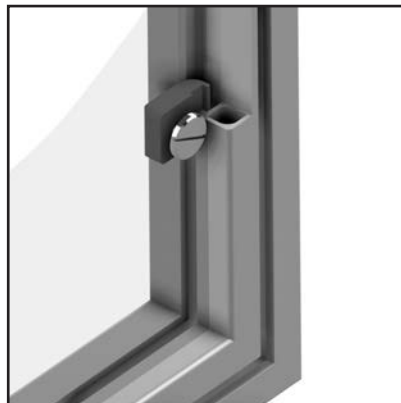
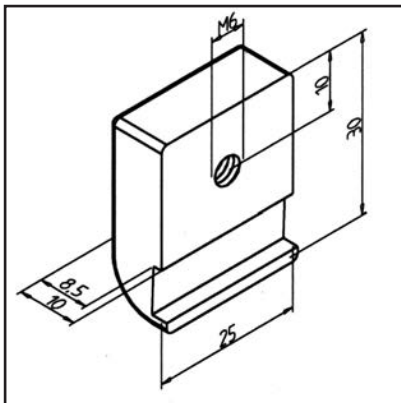

TECHN. DATA / ITEMS SUPPLIED

- Aluminium, Pressure die-casting, powder-coated, grey
- Without pan head screw
- Weight = 0.018 kg/piece

APPLICATIONS

- Fix surface elements in profile frames
- Table tops

ASSEMBLY

- Insert the thread socket into profile groove
- Fix element with screws M6 or flat head screw
- Distance from edge of the thread: 10 mm

MOUNTING BASE N PIVOTED

Part no.

21.0036/0

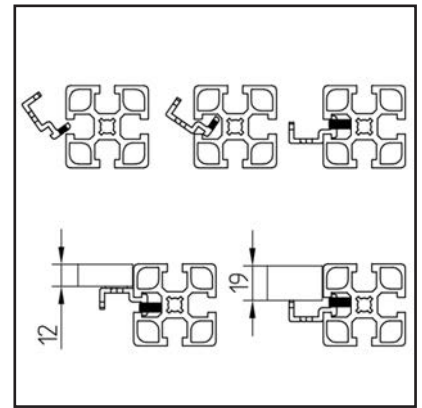
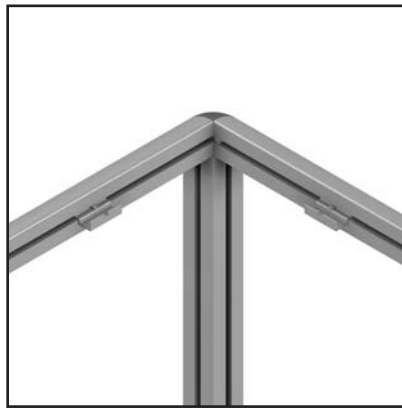
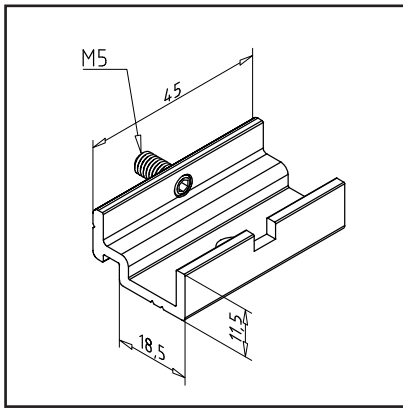

TECHN. DATA / ITEMS SUPPLIED

- Aluminium, anodized E6/EV1
- Setscrew M05, galvanised
- Weight = 0.016 kg/piece

APPLICATIONS

- For the positioning and fastening of table tops and surface elements

ASSEMBLY

- Swing into profile groove
- Clamp with set screw
- No machining required

MOUNTING BASE F PIVOTED

Part no.

21.0041/0

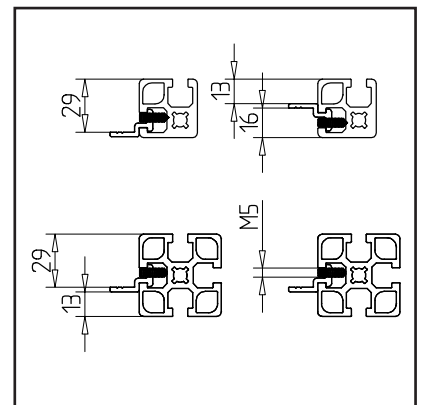
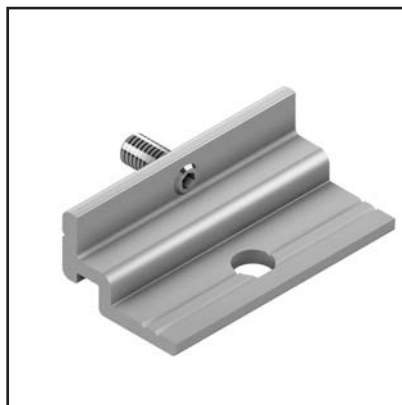
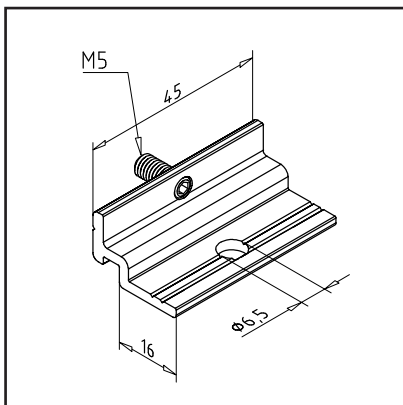

TECHN. DATA / ITEMS SUPPLIED

- Aluminium, anodized E6/EV1
- Setscrew M05, galvanised
- Weight = 0.014 kg/piece

APPLICATIONS

- For the positioning and fastening of table tops and surface elements

ASSEMBLY

- Swing into profile groove
- Clamp with set screw
- No machining required

SUPPORT PROFILE N

Part no.

20.1121/0

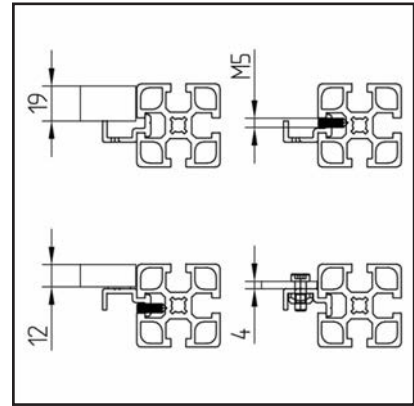
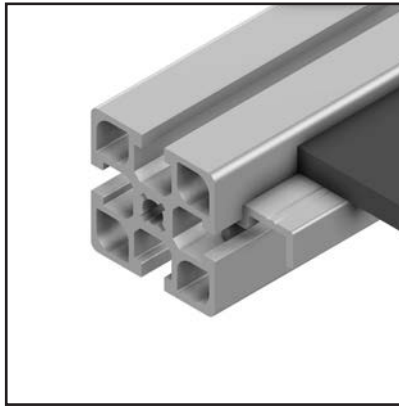
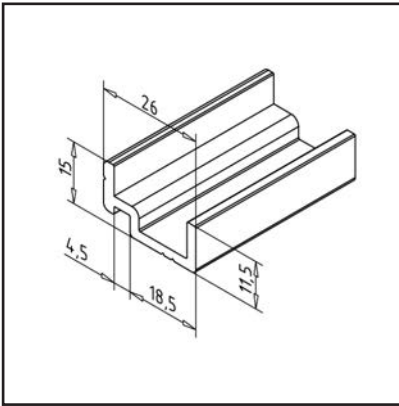

TECHN. DATA / ITEMS SUPPLIED

- Aluminium, extruded, anodized E6/EV1
- Weight = 0.339 kg/m
- Bar length = 6 m

APPLICATIONS

- All types of safety equipment
- For installation of surface elements such as panels and plates up to a thickness of 19 mm
- Subsequent insertion

ASSEMBLY

- Slide the carrier profile into the groove and if necessary, fix it with a threaded pin
- Surface element: clear opening x+y: -2 mm

SUPPORT PROFILE F

Part no.

20.1149/0

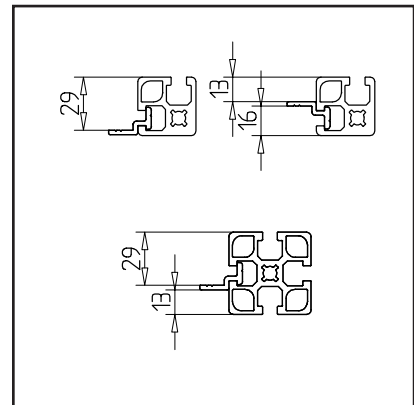
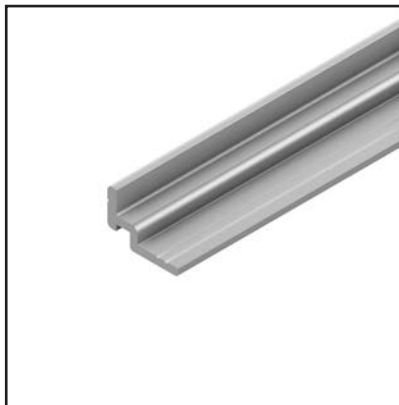
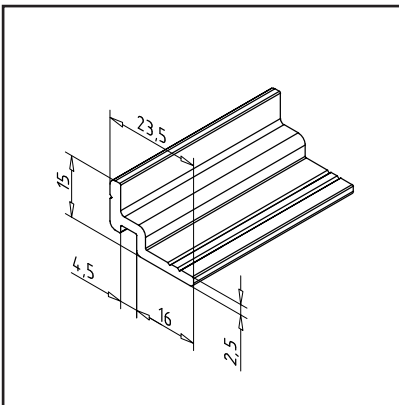

TECHN. DATA / ITEMS SUPPLIED

- Aluminium, extruded, anodized E6/EV1
- Weight = 0.262 kg/m
- Bar length = 6 m

APPLICATIONS

- All types of safety equipment
- For installation of surface elements such as panels and plates up to a thickness of 19 mm
- Subsequent insertion

ASSEMBLY

- Slide the carrier profile into the groove and if necessary, fix it with a threaded pin

CLAMPING PROFILE 32 X 32

Part no.

20.1070/0

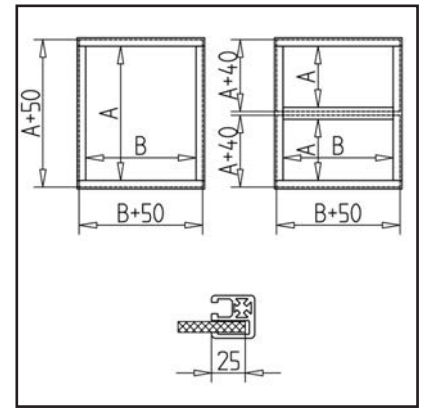
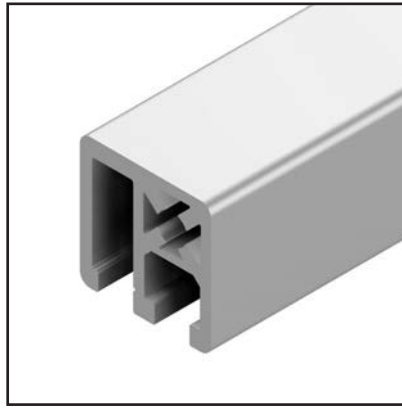
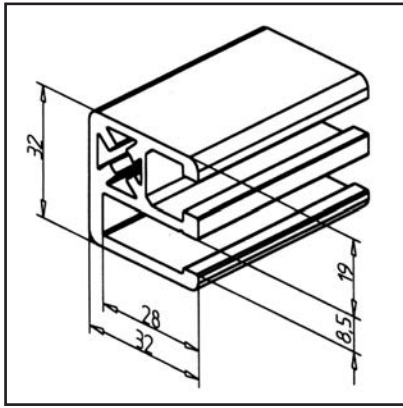

TECHN. DATA / ITEMS SUPPLIED

- Aluminium, extruded, anodized E6/EV1
- $I_x = 5.024 \text{ cm}^4$
- $I_y = 4.418 \text{ cm}^4$
- $w_x = 3.041 \text{ cm}^3$
- $w_y = 2.398 \text{ cm}^3$
- Weight = 1.211 kg/m
- Bar length = 6 m
- Packing unit = 48 m

APPLICATIONS

- All types of safety equipment
- For clamping of surface elements, such as woven mesh, panels, plates with a maximum strength of 8 mm
- In the case of larger protective fields, intermediate struts made of clamping profile 45 x 32 must be used in order to ensure adequate safety against pushing out of the surface elements; To do this, remove cover strips on clamping profile 45 x 32 mm
- Cut size of surface elements:
Dimension A/B - 40/50 mm depending on application

ASSEMBLY

- MiniTec power-lock fastener; no bores required
- No release of panel element corners required
- Pre-assemble tripartite frame
- Insert panel element and install last profile brace
- Press in the distance profile **part no. 22.1039/0** on the inside or drive in with a flat tool
- For panel elements < Mount 6 mm with matching plug-in seal or < Mount 4 mm with spacer profile and additionally suitable plug-in seal on the opposite side

CLAMPING PROFILE 45 X 32

Part no.

20.1053/0

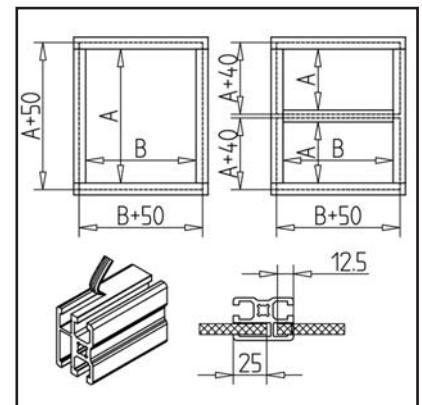
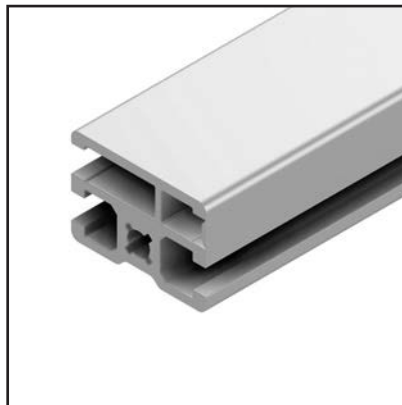
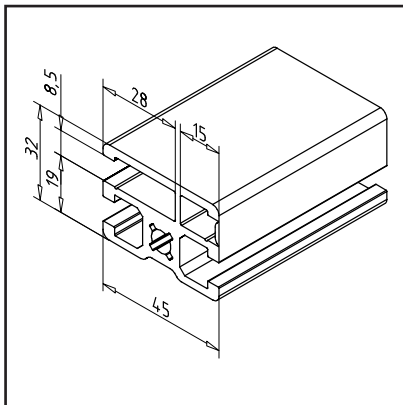

TECHN. DATA / ITEMS SUPPLIED

- Aluminium, extruded, anodized E6/EV1
- $I_x = 6.465 \text{ cm}^4$
- $I_y = 9.521 \text{ cm}^4$
- $w_x = 3.999 \text{ cm}^3$
- $w_y = 4.119 \text{ cm}^3$
- Weight = 1.615 kg/m
- Bar length = 6 m
- Packing unit = 48 m

APPLICATIONS

- In the case of larger protective fields, intermediate struts made of clamping profile 45 x 32 must be used in order to ensure adequate safety against pushing out of the surface elements; To do this, remove cover strips on clamping profile 45 x 32 mm
- All types of safety equipment
- For clamping of surface elements, such as woven mesh, panels, plates with a maximum strength of 8 mm
- Cut size of surface elements:
Dimension A/B - 40/50 mm depending on application

ASSEMBLY

- MiniTec power-lock fastener; no bores required
- No release of panel element corners required
- Pre-assemble tripartite frame
- Insert panel element and install last profile brace
- Press in the distance profile **part no. 22.1039/0** on the inside or drive in with a flat tool
- For panel elements < Mount 6 mm with matching plug-in seal or < Mount 4 mm with spacer profile and additionally suitable plug-in seal on the opposite side

DISTANCE PROFILE 30

Part no. 22.1158/0

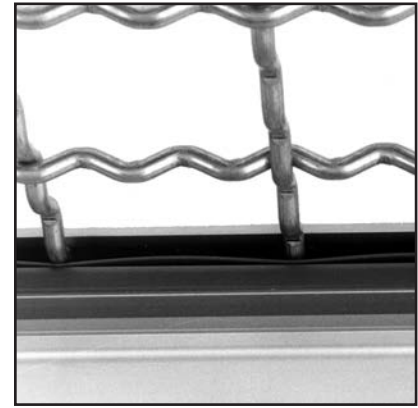
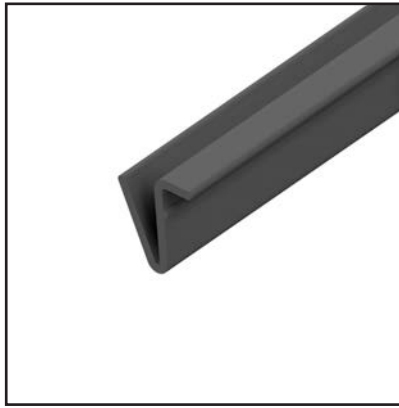
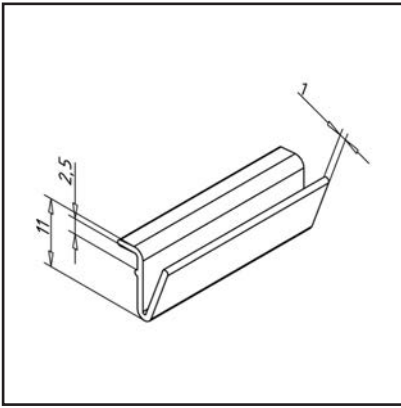

TECHN. DATA / ITEMS SUPPLIED

- ABS, extruded, grey
- Weight = 0.020 kg/m
- Bar length = 2 m

APPLICATIONS

- For clamping surface elements such as corrugated mesh, panels and plates for profile series 30

ASSEMBLY

- Mount the profile frames with the surface elements
- Push in distance profile on the inside or knock in with a flat tool

DISTANCE PROFILE

Part no. 22.1039/0

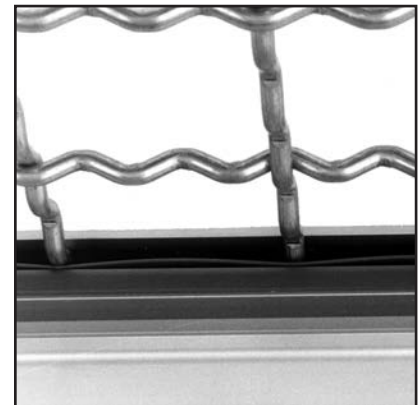
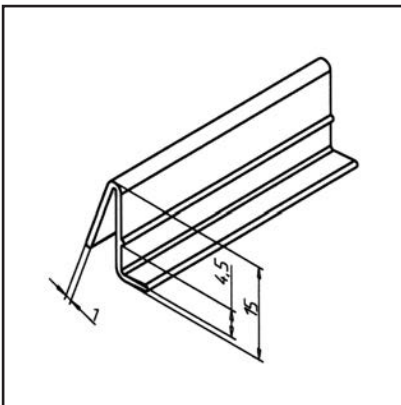

TECHN. DATA / ITEMS SUPPLIED

- ABS, extruded, grey
- Weight = 0.028 kg/m
- Bar length = 2 m

APPLICATIONS

- Use in clamping profile 45 x 32 **part no. 20.1053/0** and clamping profile 32 x 32 **part no. 20.1070/0** for clamping surface elements
- Also for use with all other profiles to fix surface elements

ASSEMBLY

- Mount the profile frames with the surface elements
- Push in distance profile on the inside or knock in with a flat tool

SCREW SOCKET PROFILE

Part no.

22.1076/0

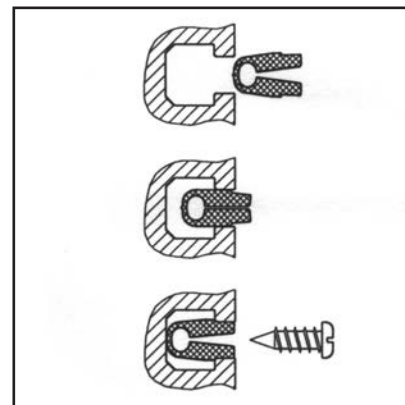
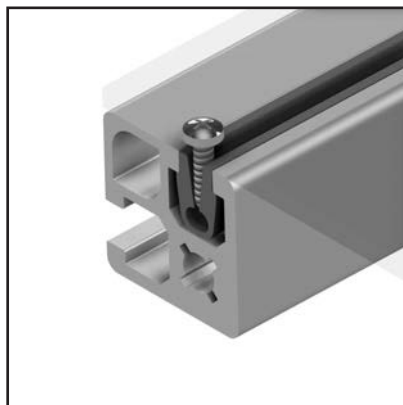
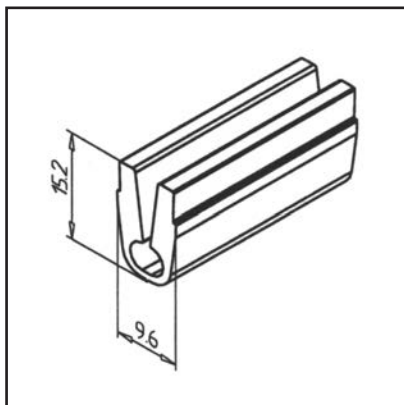

TECHN. DATA / ITEMS SUPPLIED

- PVC, extruded, grey
- Weight = 0.118 kg/m
- Bar length = 2 m

APPLICATIONS

- Fastening surface elements or components at any location

ASSEMBLY

- Clip profile into groove
- Fasten element with commercial-type self-tapping screws \varnothing 4-5 mm; Length min: 16 mm
- for material thickness of 1-6 mm, sheet metal screw 3,5 x 16 mm **part no. 21.1365/0**

PANEL CLAMPING PROFILE

Part no.

20.1025/0

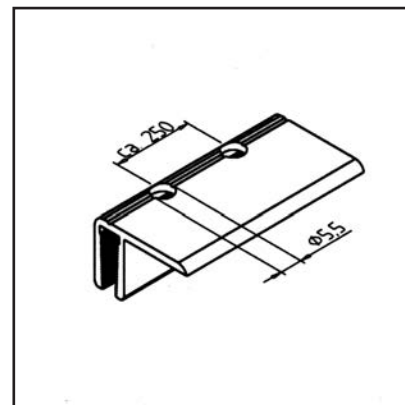
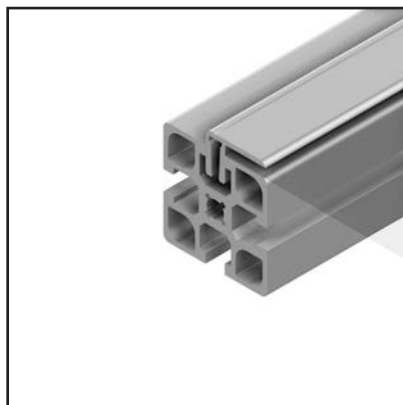
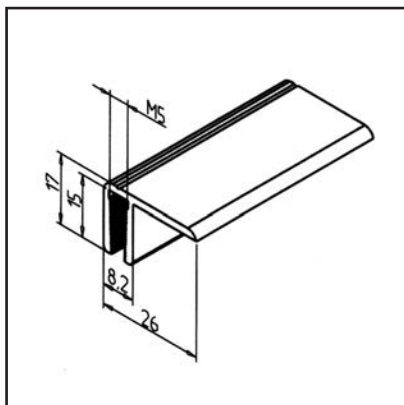

TECHN. DATA / ITEMS SUPPLIED

- Aluminium, extruded, anodized E6/EV1
- Weight = 0.260 kg/m
- Bar length = 6 m

APPLICATIONS

- Fastening of surface elements
- Post fitting of facing panels
- Reception of surface elements with a maximum strength of 10 mm

ASSEMBLY

- Place the bore \varnothing 5.5 for the threaded pin M5 in a grid size of approx. 250 mm
- Press in the profile groove and clamp with grub screw M5 x 12 **part no. 21.1381/0**

DOUBLE PANEL CLAMPING PROFILE

Part no. 20.1018/0

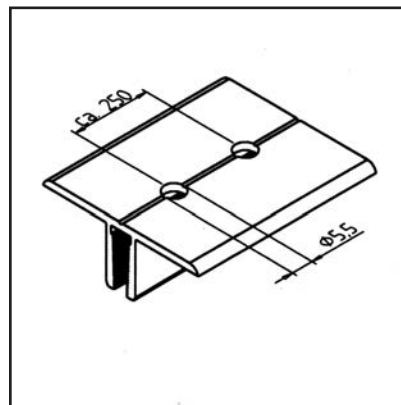
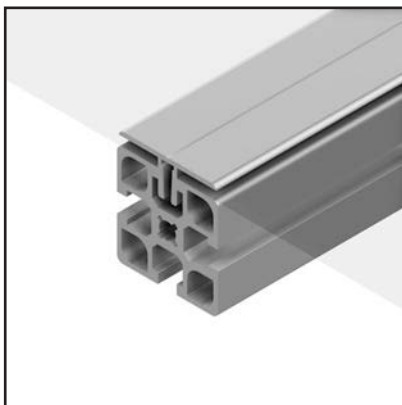
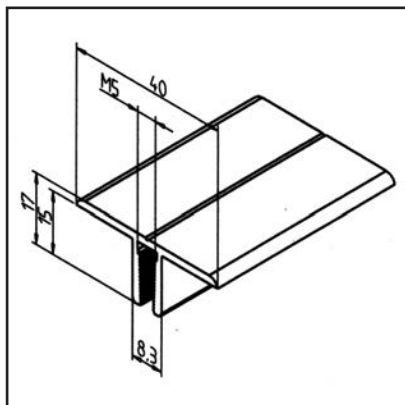

TECHN. DATA / ITEMS SUPPLIED

- Aluminium, extruded, anodized E6/EV1
- Weight = 0.375 kg/m
- Bar length = 6 m

APPLICATIONS

- Attachment of panels on the outer face in the region of a butt joint
- Reception of surface elements with a maximum strength of 10 mm

ASSEMBLY

- Place the bore $\varnothing 5.5$ for the threaded pin M5 in a grid size of approx. 250 mm
- Press in the profile groove and clamp with grub screw M5 x 12 **part no. 21.1381/0**
- See also surface clamping profile **part no. 20.1025/0**

PANEL HOLDER GREY

Part no. 22.1090/1

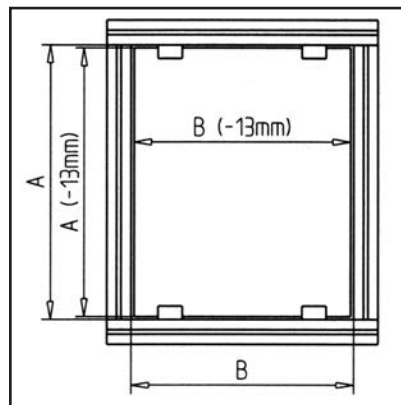
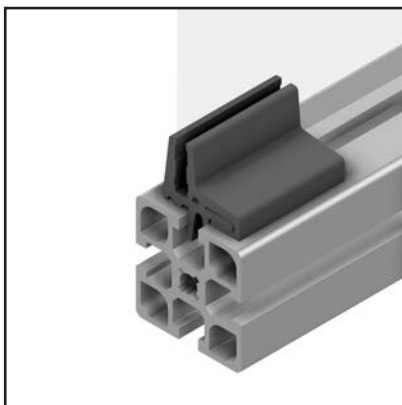
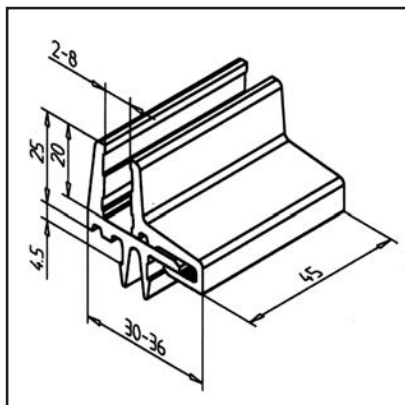

TECHN. DATA / ITEMS SUPPLIED

- PVC, extruded, grey
- On request also available in black, **part no. 22.1090/0**
- Weight = 0.011 kg/piece

APPLICATIONS

- Fixation surface elements with a maximum strength of 8 mm
- For surface elements smaller than 4 mm, a moss rubber strip must be inserted
- Windows, doors
- Not suitable for corrugated mesh

ASSEMBLY

- Fold the sockets into the profile groove
- Insert the panel element
- Press clamping half firmly on socket half

CLAMPING PROFILE PVC

Part no.

22.1092/0

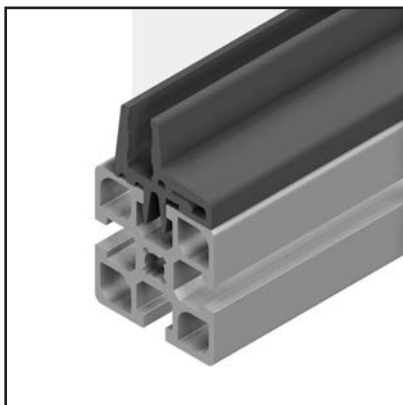
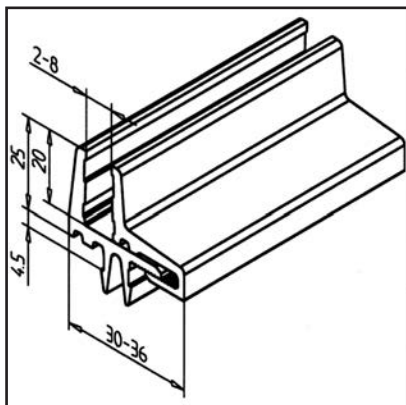

TECHN. DATA / ITEMS SUPPLIED

- PVC, extruded, grey
- On request also available in black, **part no. 22.1080/0**
- Weight = 0.550 kg/m
- Bar length = 2 m

APPLICATIONS

- Fixation surface elements with a maximum strength of 8 mm
- For surface elements smaller than 4 mm, a moss rubber strip must be inserted
- Windows, doors
- No free space between profile and panel element
- Also suitable for corrugated mesh

ASSEMBLY

- Snap socket half into profile groove
- Insert the panel element
- Press clamping half firmly on socket half

PANEL FRAMING PROFILE

Part no.

22.1107/1

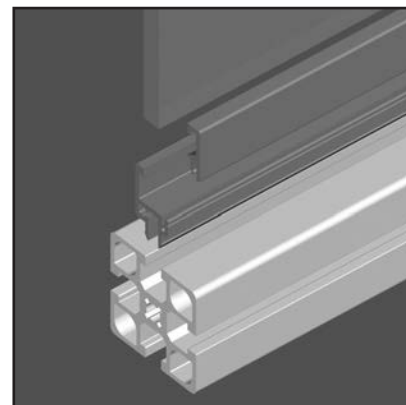
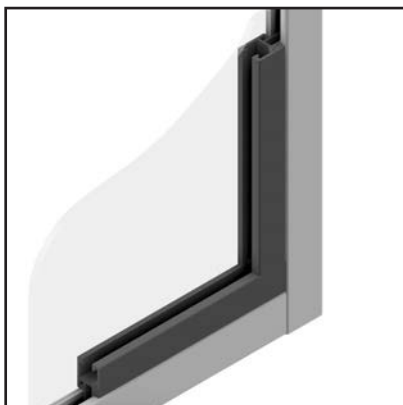
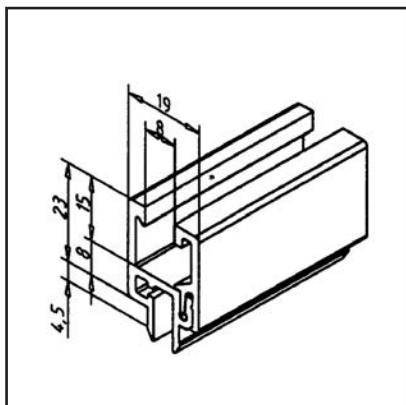

TECHN. DATA / ITEMS SUPPLIED

- ABS, extruded, grey
- On request also available in black **part no. 22.1107/0**
- Weight = 0.229 kg/m
- Bar length = 2 m

APPLICATIONS

- For retrofitting surface elements in existing profile frames
- Fixation surface elements with a maximum strength of 8 mm
- For panels up to 8 mm use additional insert seal
- For subsequent installation of corrugated mesh please use clamp profile PVC
- Windows, doors
- No free space between profile and panel element

ASSEMBLY

- Snap socket half into profile groove
- Insert the panel element
- Press clamping half firmly on socket half
- **No mitre cut necessary**

SURFACE ELEMENTS

MATERIAL & CHOICES

ACRYL

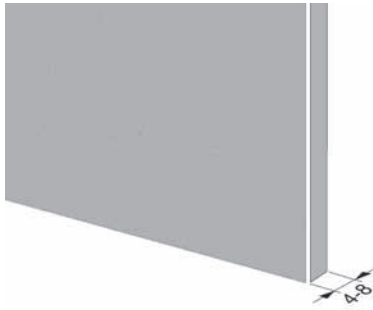

Part no.	STRENGTH	COLOUR	WEIGHT	PLATE SIZE
21.1832/0	4 mm	smoke-coloured	4,76 kg/m ²	2050 x 3050 mm
21.1811/0	5 mm	smoke-coloured	5,95 kg/m ²	2050 x 3050 mm
21.1812/0	6 mm	smoke-coloured	7,14 kg/m ²	2050 x 3050 mm
21.1813/0	8 mm	smoke-coloured	9,52 kg/m ²	2050 x 3050 mm
21.1826/0	4 mm	crystal clear	4,76 kg/m ²	2050 x 3050 mm
21.1836/0	5 mm	crystal clear	5,95 kg/m ²	2050 x 3050 mm
21.1827/0	6 mm	crystal clear	7,14 kg/m ²	2050 x 3050 mm
21.1828/0	8 mm	crystal clear	9,52 kg/m ²	2050 x 3050 mm

POLYCARBONATE

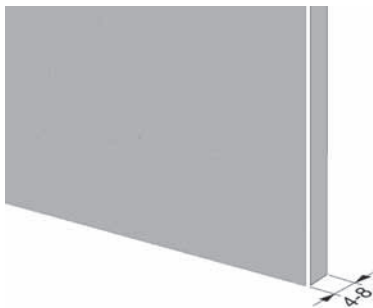

Part no.	STRENGTH	COLOUR	WEIGHT	PLATE SIZE
21.1809/0	4 mm	smoke-coloured	4,76 kg/m ²	2050 x 3050 mm
21.1808/0	5 mm	smoke-coloured	5,95 kg/m ²	2050 x 3050 mm
21.1807/0	6 mm	smoke-coloured	7,20 kg/m ²	2050 x 3050 mm
21.1821/0	8 mm	smoke-coloured	9,78 kg/m ²	2050 x 3050 mm
21.1829/0	4 mm	crystal clear	4,80 kg/m ²	2050 x 3050 mm
21.1833/0	5 mm	crystal clear	5,95 kg/m ²	2050 x 3050 mm
21.1830/0	6 mm	crystal clear	7,20 kg/m ²	2050 x 3050 mm
21.1831/0	8 mm	crystal clear	9,78 kg/m ²	2050 x 3050 mm

WAVE GRID

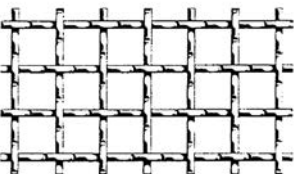

Part no.	WIRE STRENGTH	MESH WIDE	WEIGHT	PLATE SIZE	MATERIAL
21.1803/0	4 mm	30 mm	6,2 kg/m ²	2000 x 3000 mm	pc, galvanized
21.1805/0	4 mm	40 mm	4,7 kg/m ²	2000 x 3000 mm	pc, galvanized
21.1818/2	4 mm	30 mm	2,14 kg/m ²	2000 x 2000 mm	ALMg3
21.1818/1	4 mm	40 mm	1,6 kg/m ²	2000 x 2000 mm	ALMg3

ALUMINIUM-WAVE PANEL

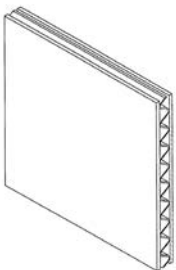

Part no.	21.1853/0
Front	0,8 mm
Back	0,5 mm
Aluminium Shaft	0,2 mm
total thickness	6 mm
Weight	4,6 kg/m ²
Plate size	1500 x 3000 mm
Material	Aluminum adhesive coated on both sides, paintable, printable, recyclable

COMPOSITE

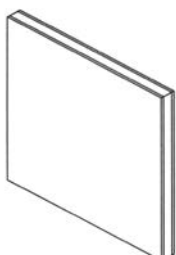

Part no.	21.1834/0
Material outside	Aluminium (anodized)
Material inside	Polyethylene
total thickness	6 mm
Weight	7,3 kg/m ²
Plate size	1250 x 2500 mm
Others	paintable, printable, recyclable

ON DEMAND Aluminium sheets, steel plates, perforated sheets, plywood panels

SURFACE ELEMENTS

MATERIAL & CHOICES

Extremely scratch-resistant, water-resistant and resistant to a variety of chemicals, acids and alkalis.

HPL compact tabletop

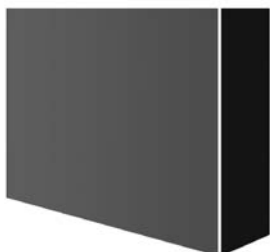

part no.	Color	Thickness	Weight	Size	ESD
32.6201/0	light grey	5	7 Kg/m ²	2520 x 1280	Nein
32.6202/0	light grey	8	11,2 Kg/m ²	2520 x 1280	Nein
32.6203/0	light grey	16	22,4 Kg/m ²	2520 x 1280	Nein
32.6204/0	light grey	20	30 Kg/m ²	2520 x 1280	Nein
32.6205/0	light grey	8	11,2 Kg/m ²	2520 x 1280	Ja
32.6206/0	light grey	10	14 Kg/m ²	2520 x 1280	Ja
32.6207/0	light grey	16	22,4 Kg/m ²	2520 x 1280	Ja
32.6208/0	light grey	20	30 Kg/m ²	2520 x 1280	Ja

PVC-PLATE

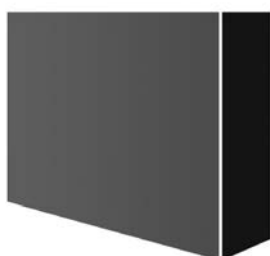

Part no.	21.1817/0
Thickness	20 mm
Color	grey, 7011 RAL
Weight	28 kg/m ²
Plate size	1000 x 2000 mm
Others	other colours and strengths, Anti-static Tabletops on request

RECYCLING-PLATE PE

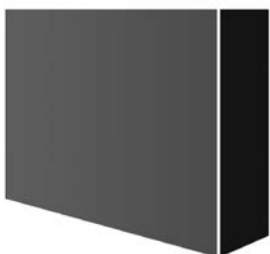

Part no.	32.0406/0
Thickness	10 - 40 mm
Colour	black
Plate size	1000 x 2000 mm
Density	0,93 kg/dm ³
Others	PE-Regenerated

RECYCLING-PLATE PE CONFETTI

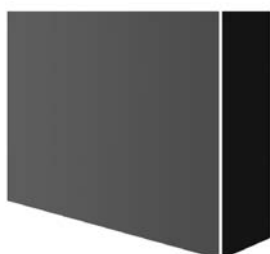

Part no.	32.0405/0
Thickness	10 - 40 mm
Colour	confetti
Plate size	1000 x 2000 mm
Density	0,93 kg/dm ³
Others	PE-Regenerated

*(The colour spread may vary depending on the delivery in shape, colour and size)

EDGING AND COVER PROFILE

Part no. ---,---/-

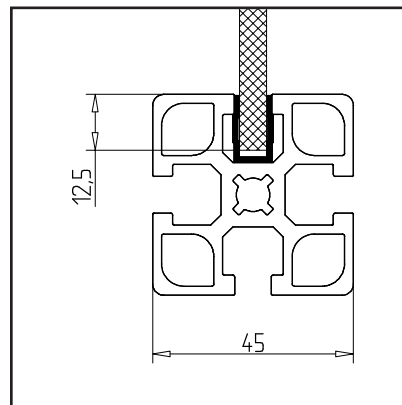
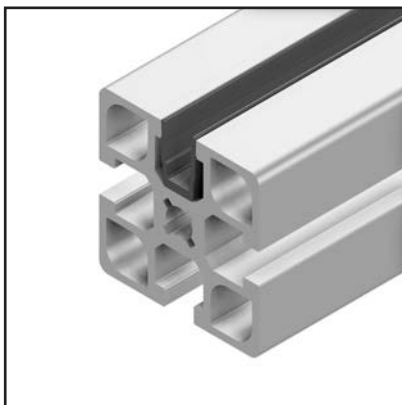
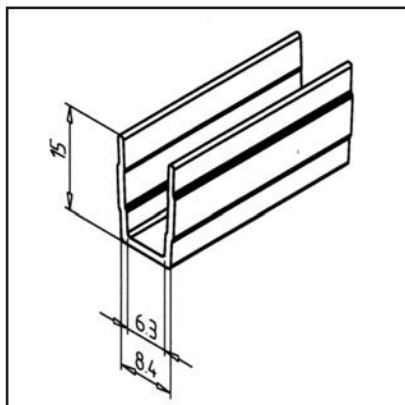

TECHN. DATA / ITEMS SUPPLIED

APPLICATIONS

ASSEMBLY

- PVC black **part no. 22.1070/0**
- PVC grey **part no. 22.1070/1**
- PVC light grey **part no. 22.1070/2**
- PVC blue **part no. 22.1072/0**
- PVC orange **part no. 22.1071/0**
- PVC yellow **part no. 22.1074/0**
- ABS silver **part no. 22.1179/0**
- Weight = 0.060 kg/m
- Bar length = 2 m

- Mounted with groove inwards: For closing profile grooves
- **Mounted with the groove to the outside:**
For the absorption of surface elements up to 6 mm thickness, dimensional compensation by silicone or sponge rubber cord **part no. 22.1102/0**

- Snap or slip into profile groove

COVER PROFILE 30

Part no. ---,---/-

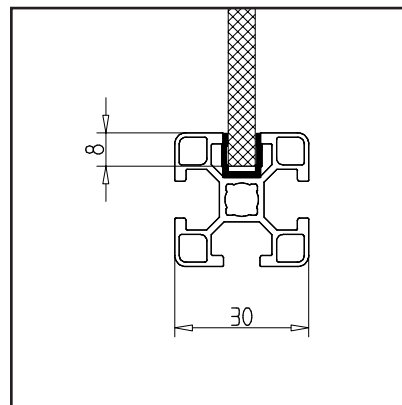
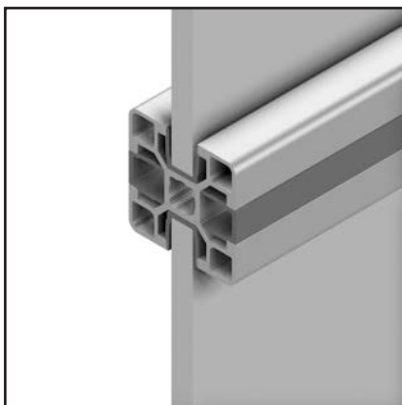
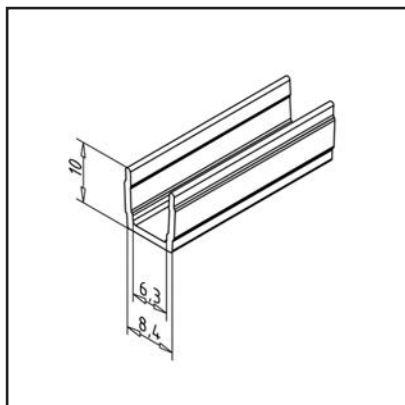

TECHN. DATA / ITEMS SUPPLIED

APPLICATIONS

ASSEMBLY

- PVC, extruded
- grey **part no. 22.1161/1**
- light grey **part no. 22.1161/2**
- Weight = 0.040 kg/m
- Bar length = 2 m

- Mounted with groove inwards: For closing profile grooves
- **Mounted with the groove to the outside:**
For the absorption of surface elements up to 6 mm thickness, dimensional compensation by silicone or sponge rubber cord **part no. 22.1102/0**

- Press or slide into the profile groove

COVER PROFILE K

Part no.

--...../-

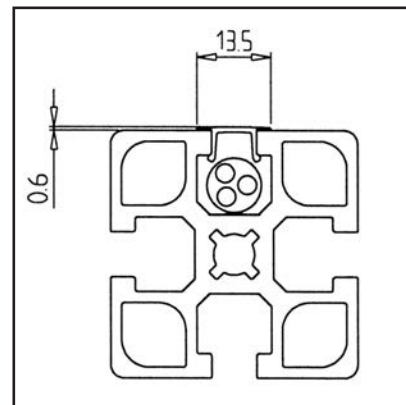
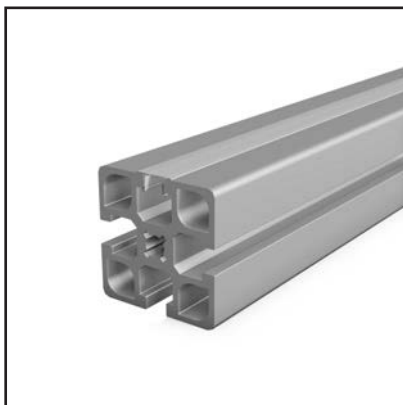
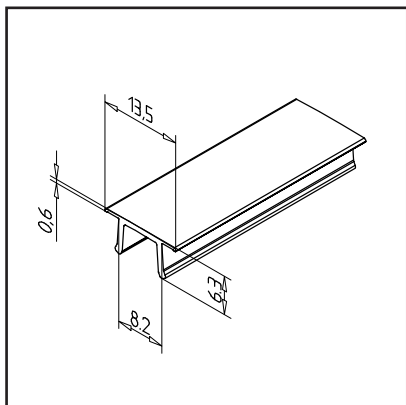

TECHN. DATA / ITEMS SUPPLIED

- ABS, grey **part no. 22.1020/1**
- PP, transparent **part no. 22.1020/3**
- ABS, yellow **part no. 22.1020/4**
- Weight = 0.023 kg/m
- Bar length = 2 m

APPLICATIONS

- Dust-tight sealing of the profile grooves
- The groove cross-section remains largely free for laying cables or hoses.
- Information plates
- The transparent cover profile can be used to cover lighting elements in the profile groove, e.g. LED strips.

ASSEMBLY

- Press by hand onto profile groove

COVER PROFILE G

Part no.

22.1010/0

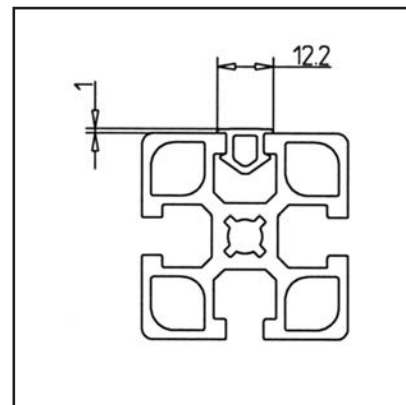
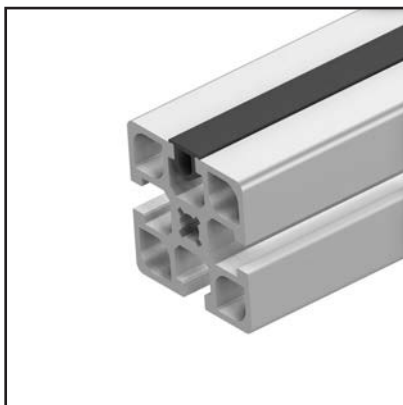
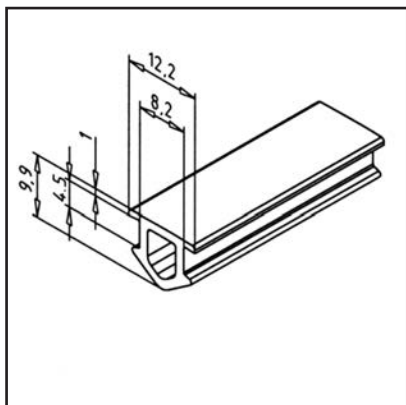

TECHN. DATA / ITEMS SUPPLIED

- NBR, black
- Roll length 100 m
- Hardness (Shore A) 70°
- Weight = 0.072 kg/m

APPLICATIONS

- Dust-tight sealing of the profile grooves
- The groove cross-section remains largely free for laying cables or hoses.

ASSEMBLY

- Press by hand onto profile groove

COVER PROFILE L

Part no.

20.1021/0

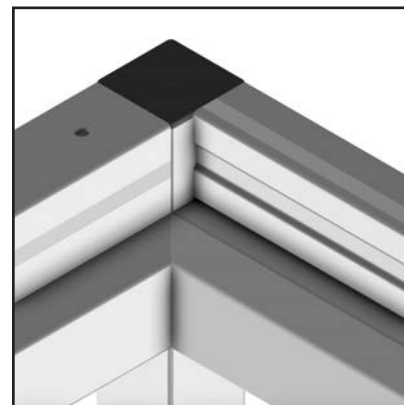
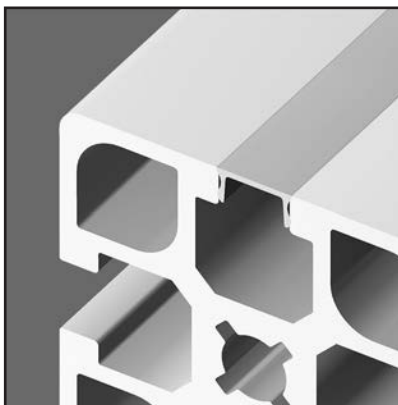
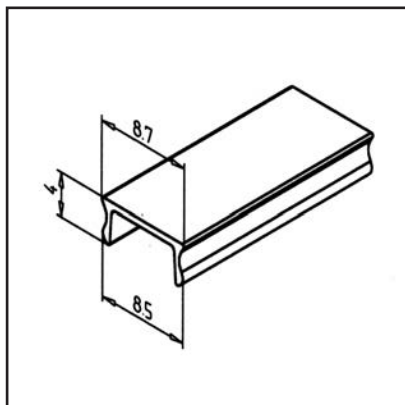

TECHN. DATA / ITEMS SUPPLIED

- Aluminium, extruded, bright
- **On request also anodized available part no. 20.1021/1**
- Weight = 0.030 kg/m
- Bar length = 2 m

APPLICATIONS

- Flush, dust-tight sealing of the profile grooves
- The groove cross-section remains largely free for laying cables or hoses.
- Information plates

ASSEMBLY

- Press by hand onto profile groove

SIGNAL PROFILE

Part no.

---,----/-

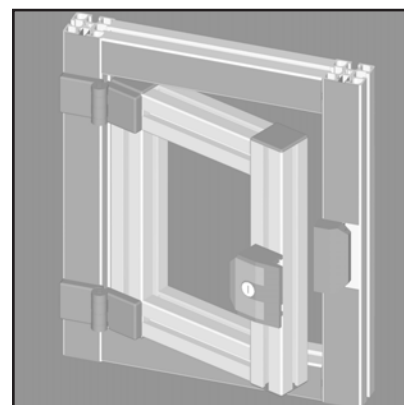
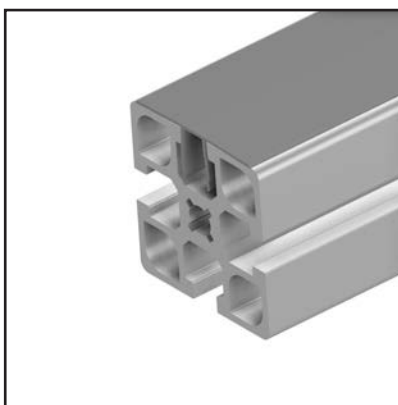
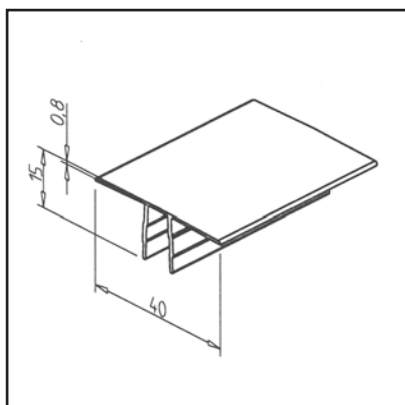

TECHN. DATA / ITEMS SUPPLIED

- PVC, extruded
- yellow-orange **part no. 22.1097/2**
- fire red **part no. 22.1097/3**
- signal yellow **part no. 22.1097/4**
- Weight = 0.090 kg/m
- Bar length = 2 m

APPLICATIONS

- Marking of safety relevant construction units such as doors and risk zones
- Coloured organization of constructions or parts

ASSEMBLY

- Clip in profile groove

EDGE PROTECTION

Part no.

--...../-

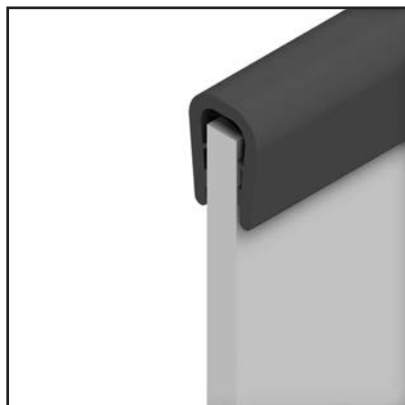
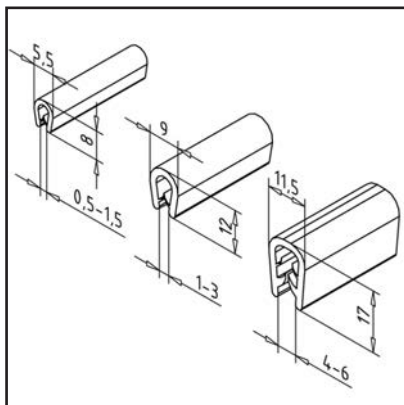

TECHN. DATA / ITEMS SUPPLIED

- PVC, black
- Steel plate reinforced
- Edge protection 0,5-1,5 **part no. 22.1029/0**
Weight: 0,050 kg/m, Roll length 50 m
- Edge protection 1,0-3,0 **part no. 22.1036/0**
Weight: 0,120 kg/m, Roll length 100 m
- Edge protection 4,0-6,0 **part no. 22.1037/0**
Weight: 0,190 kg/m, Roll length 100 m

APPLICATIONS

- Edge protection for surface elements
- Protection of MiniTec conduit
- Protection of bores and openings

ASSEMBLY

- Press onto edge of panel element

PLUG SEAL 30

Part no.

22.1174/0

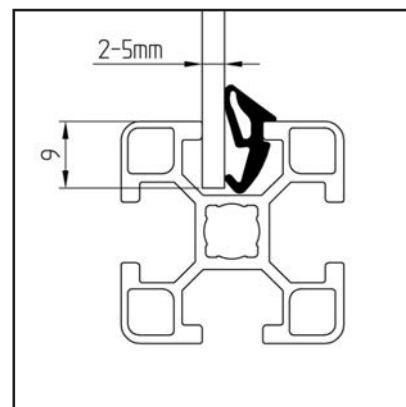
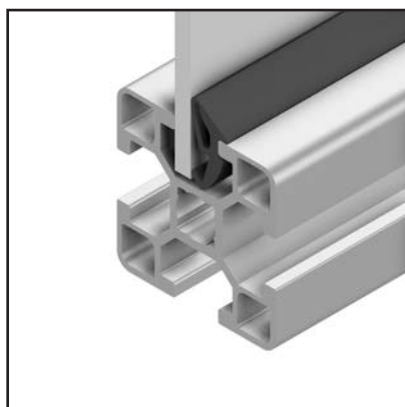
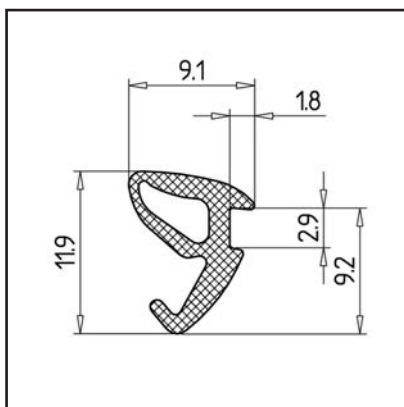

TECHN. DATA / ITEMS SUPPLIED

- EPDM, black
- Roll length 100 m
- Weight = 0.050 kg/m

APPLICATIONS

- Fastening and sealing of panels directly in the profile groove, for panels 2-5 mm thick

ASSEMBLY

- Insert panel into profile groove, next push gasket in manually or with an appropriate, wooden or plastic tool
- When using profile connectors 30 for connecting the profiles, the surface elements should be given on 2 sides instead of 9 mm only an allowance of 7.5 mm

PLUG SEAL 2

Part no.

22.1083/0

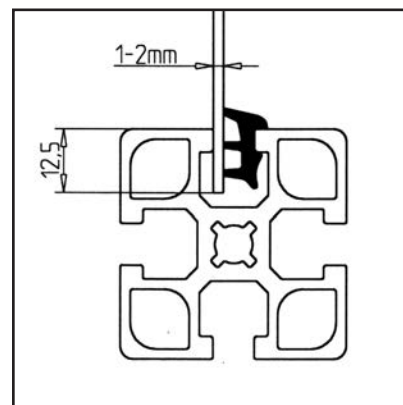
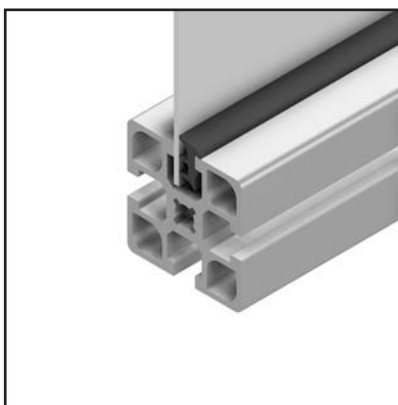
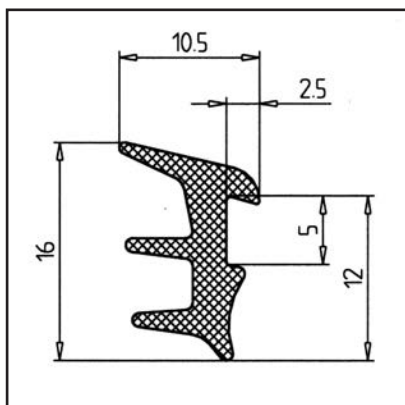

TECHN. DATA / ITEMS SUPPLIED

APPLICATIONS

ASSEMBLY

- EPDM, black
- Roll length 100 m
- Weight = 0.096 kg/m

- Not suitable for acrylic glass and polycarbonate
- Fastening and sealing of surface elements directly in the profile groove up to 2 mm thickness

- Insert panel into profile groove
- Press insert seal subsequently into free space between panel element and profile groove with blunt tool made of wood or plastic
- Materials with <2 mm thickness can be clamped by using sealing gasket 6 on both sides, **part no. 22.1086/1**

PLUG SEAL 4

Part no.

22.1081/0

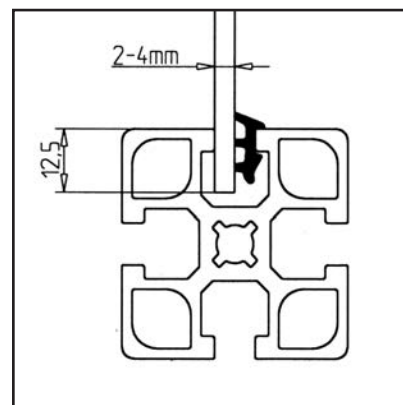
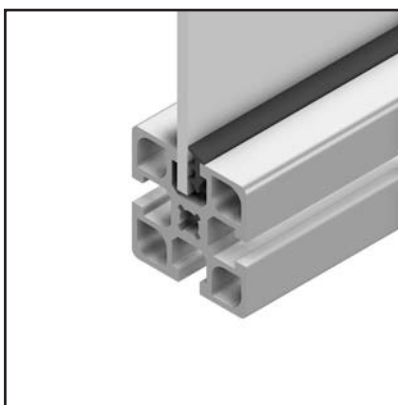
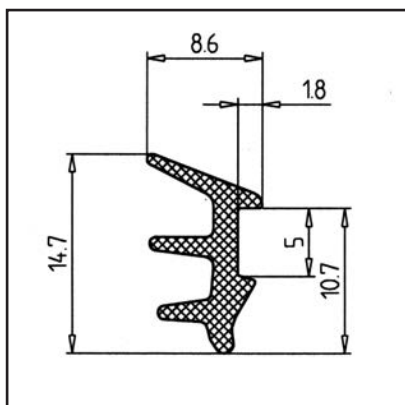

TECHN. DATA / ITEMS SUPPLIED

APPLICATIONS

ASSEMBLY

- EPDM, black
- Roll length 100 m
- Weight = 0.070 kg/m

- Fastening and sealing of panes directly in the profile groove, for panes 2-4 mm thick
- Also suitable for acrylic plastic and polycarbonate

- Slide the pane into the profile groove, afterwards press the sealing gasket manually or with a suitable dull tool made of wood or plastic

PLUG SEAL 5

Part no.

22.1099/0

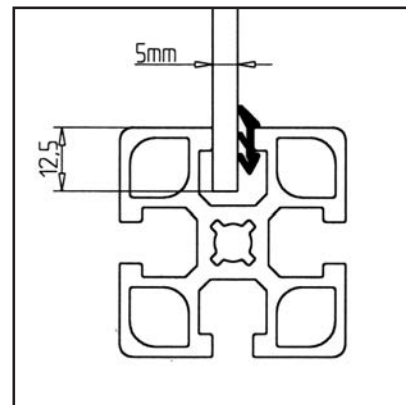
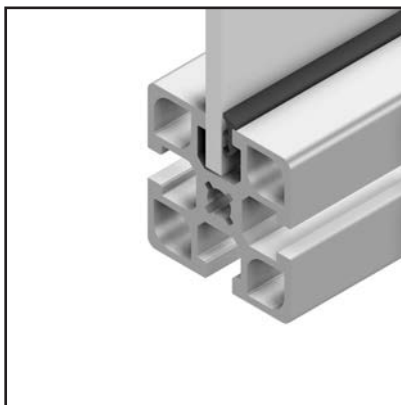
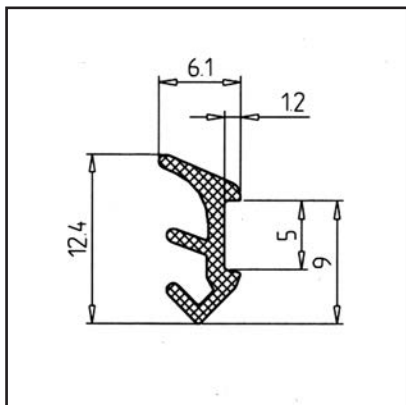

TECHN. DATA / ITEMS SUPPLIED

- EPDM, black
- Roll length 100 m
- Weight = 0.040 kg/m

APPLICATIONS

- Fastening and sealing of panels directly in the profile groove, for panels up to 5 mm thick
- Also suitable for acrylic plastic and polycarbonate

ASSEMBLY

- Slide the pane into the profile groove, afterwards press the sealing gasket manually or with a suitable dull tool made of wood or plastic

PLUG SEAL 6

Part no.

22.1086/1

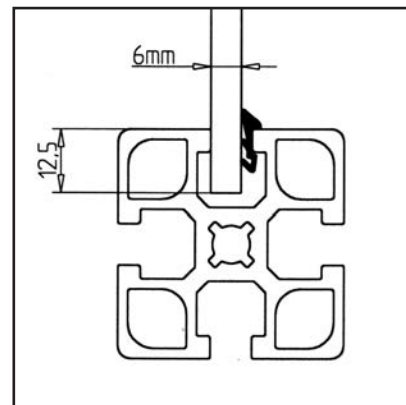
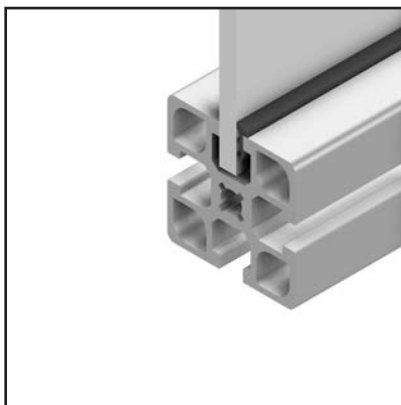
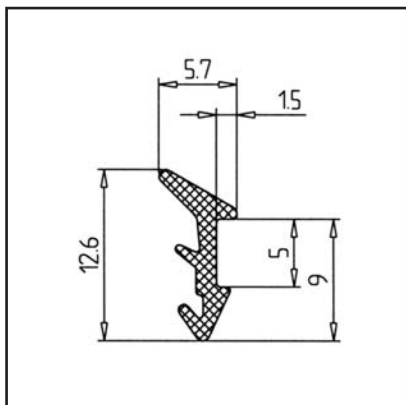

TECHN. DATA / ITEMS SUPPLIED

- EPDM, black
- Oil-resistant version insert seal NBR, **part no. 22.1086/3**
- Roll length 100 m
- Weight = 0.033 kg/m

APPLICATIONS

- Fastening and sealing of panels directly in the profile groove, for panels up to 6 mm thick
- Also suitable for acrylic plastic and polycarbonate

ASSEMBLY

- Slide the pane into the profile groove, afterwards press the sealing gasket manually or with a suitable dull tool made of wood or plastic

PLUG SEAL 6,5

Part no.

22.0991/0

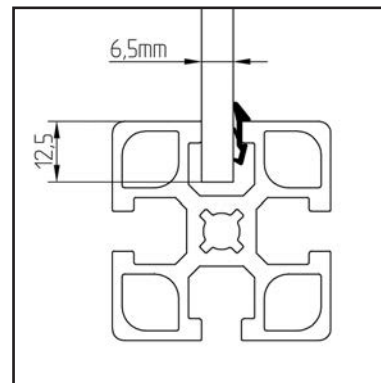
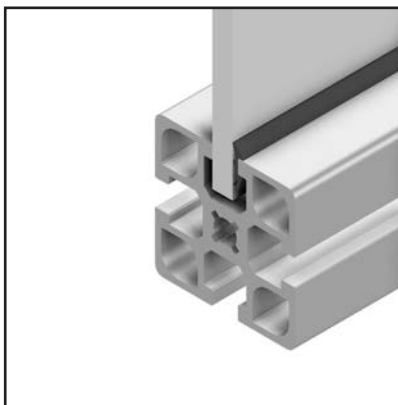
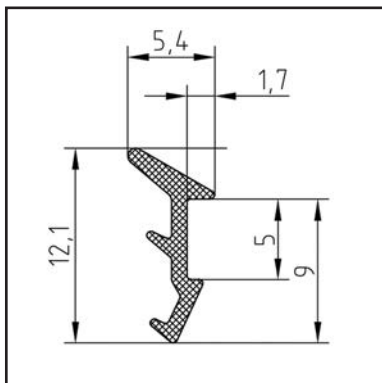

TECHN. DATA / ITEMS SUPPLIED

- EPDM, black
- Roll length 100 m
- Weight = 0.033 kg/m

APPLICATIONS

- Mounting and sealing of discs directly in the profile groove, for panels up to 6.5 mm thickness
- Also suitable for acrylic plastic and polycarbonate

ASSEMBLY

- Insert panel into profile groove, next push gasket in manually or with an appropriate, blunt wooden or plastic tool

GUIDE PROFILE 2

Part no.

22.1073/1

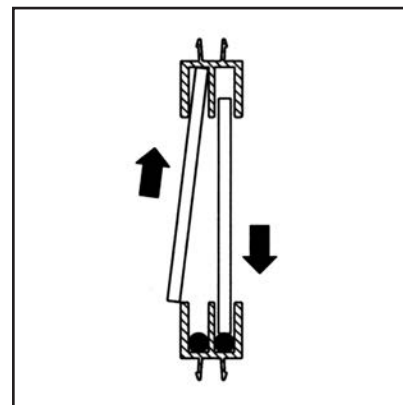
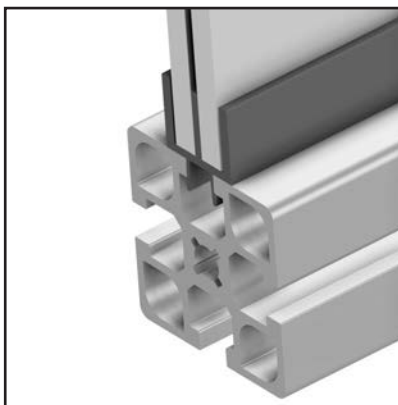
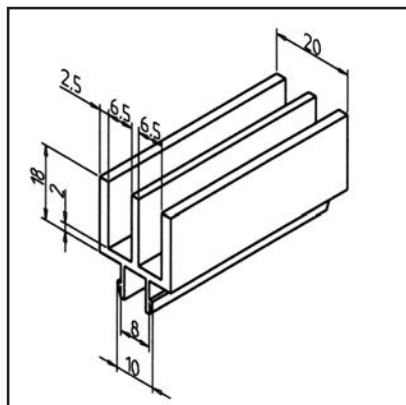

TECHN. DATA / ITEMS SUPPLIED

- PVC, extruded, grey
- On request also available in black, **part no. 22.1073/0**
- Weight = 0.270 kg/m
- Bar length = 2 m

APPLICATIONS

- 2-fold sliding window made of surface elements up to 6 mm thick

ASSEMBLY

- Press into profile groove
- Suitable for subsequent mounting
- For retrofitting the surface elements must be inserted in the grooves of the lower guide profile round rods **part no. 22.1077/0**
- Determination of dimensions for surface elements for subsequent mounting: Light height- 20 mm, further light height - 10 mm

GUIDE PROFILE 3

Part no.

22.1075/1

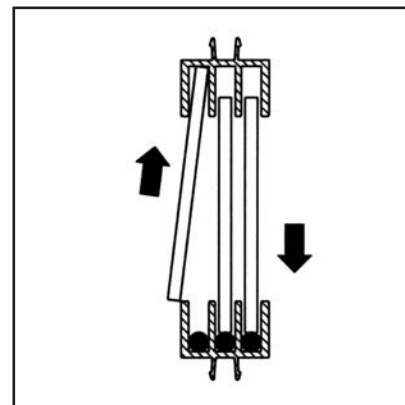
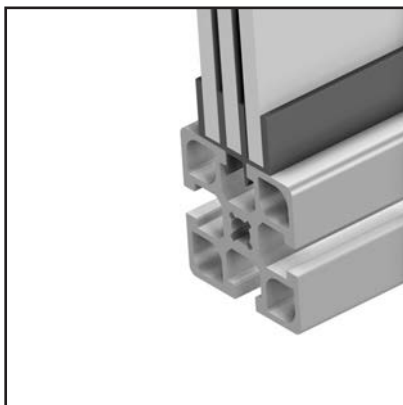
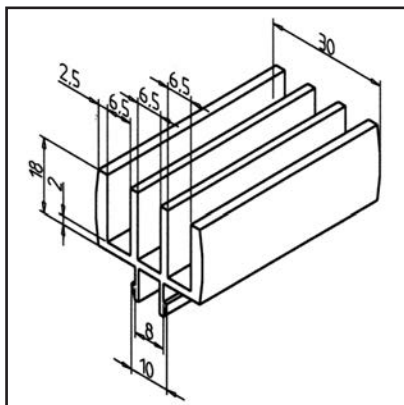

TECHN. DATA / ITEMS SUPPLIED

- PVC, extruded, grey
- On request also available in black, **part no. 22.1075/0**
- Weight = 0.340 kg/m
- Bar length = 2 m

APPLICATIONS

- 3-fold sliding window made of surface elements up to 6 mm thick

ASSEMBLY

- Press into profile groove
- Suitable for subsequent mounting
- For retrofitting the surface elements must be inserted in the grooves of the lower guide profile round rods **part no. 22.1077/0**
- Determination of dimensions for surface elements for subsequent mounting: Light height- 20 mm, further light height - 10 mm

ROUND ROD

Part no.

22.1077/0

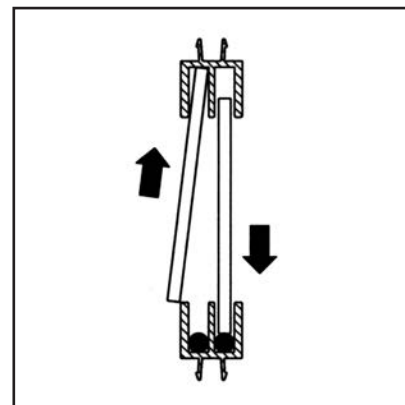
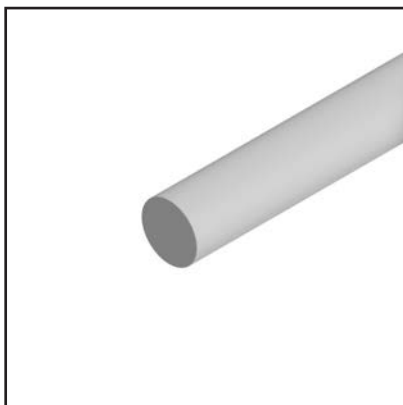
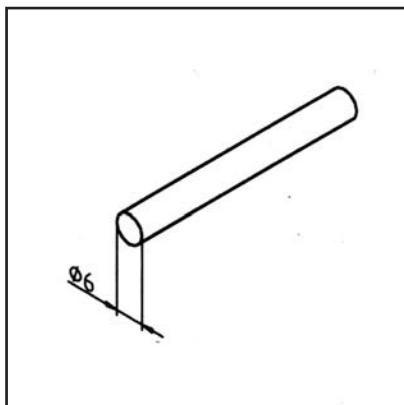

TECHN. DATA / ITEMS SUPPLIED

- PA, extruded
- Ø 6 mm
- Weight = 0.040 kg/m
- Bar length = 3 m

APPLICATIONS

- Guiding of windows or doors in guide profiles

ASSEMBLY

- Insertion into lower guide grooves of guide profiles 2 and 3

U-PROFILE

Part no.

21.1002/0

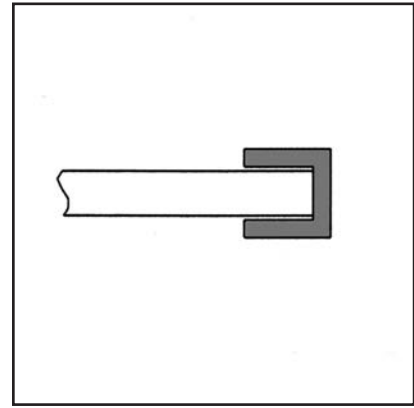
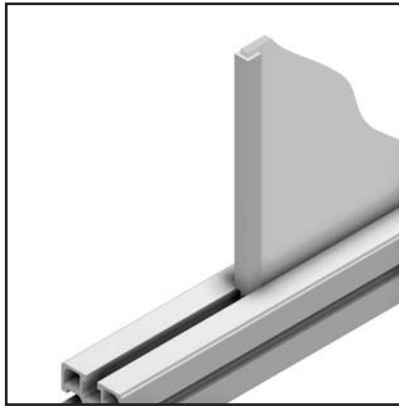
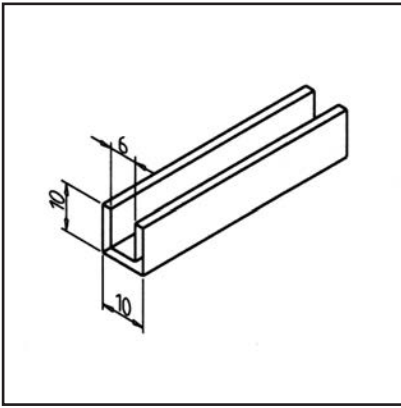

TECHN. DATA / ITEMS SUPPLIED

- Aluminium, extruded, anodized E6/EV1
- Weight = 0.150 kg/m
- Bar length = 6 m

APPLICATIONS

- Fitting panels, for surface elements of 5 mm thickness

ASSEMBLY

- Glue on edges of surface elements with suitable adhesive

SEALING STRIP

Part no.

22.1078/0

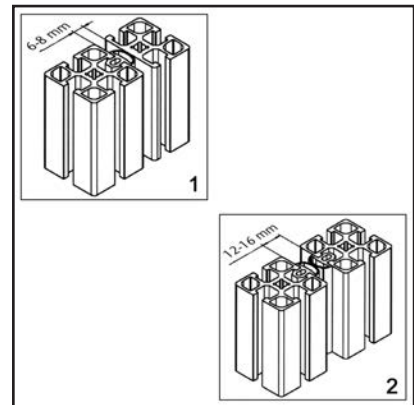
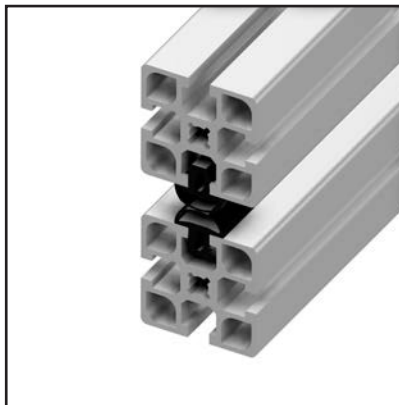
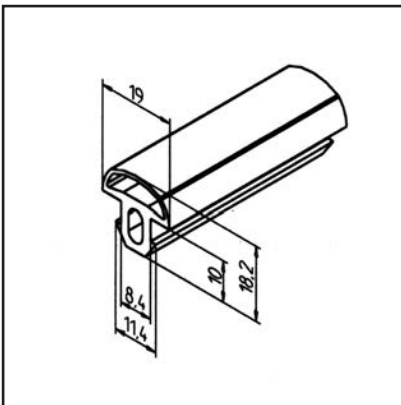

TECHN. DATA / ITEMS SUPPLIED

- NBR, black
- Hardness (Shore A) 70°
- Roll length 50 m
- Weight = 0.175 kg/m

APPLICATIONS

- Sealing of doors, lids and other constructions against water, dust and noise

ASSEMBLY

- Press into profile groove
- 1. One-sided sealing: Gap width 6 - 8 mm
- 2. Double-sided sealing: Gap width 12 - 16 mm

SEALING PROFILE

Part no.

22.1011/0

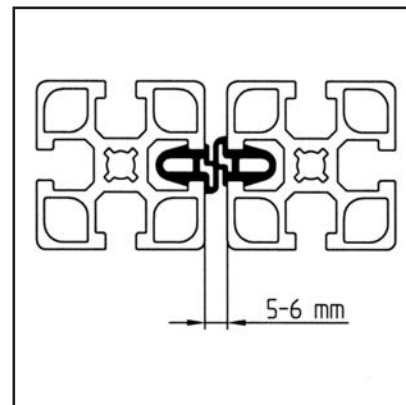
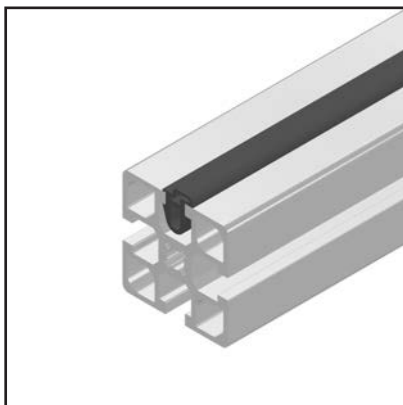
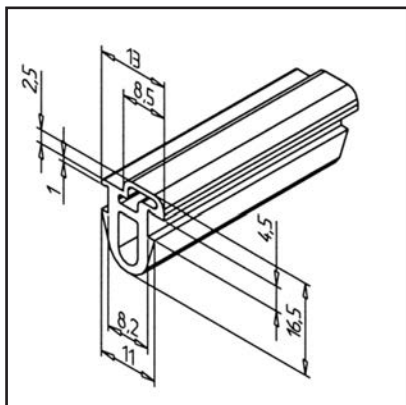

TECHN. DATA / ITEMS SUPPLIED

- NBR, black
- Hardness (Shore A) 70°
- Roll length 50 m
- Weight = 0.122 kg/m

APPLICATIONS

- Sealing of doors, lids and other constructions against water, dust and noise

ASSEMBLY

- Press into profile groove

SEALING LIP PROFILE

Part no.

22.1038/0

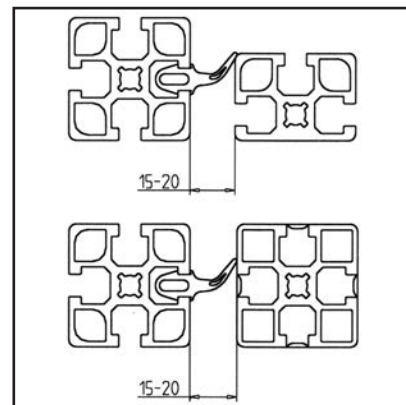
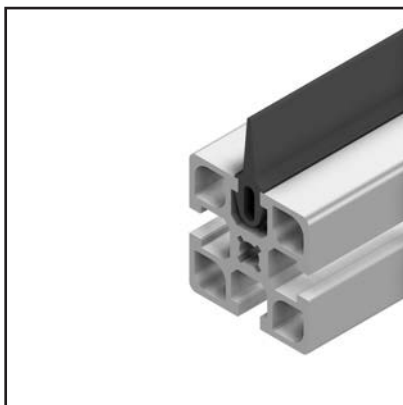
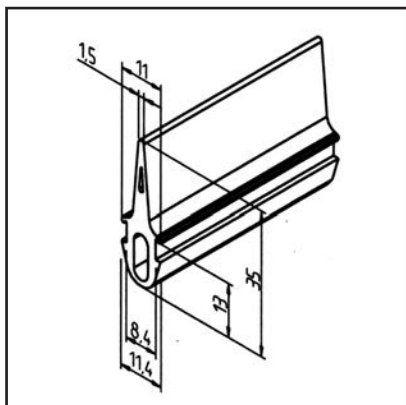

TECHN. DATA / ITEMS SUPPLIED

- NBR, black
- Hardness (Shore A) 60°
- Roll length 75m
- Weight = 0.245 kg/m

APPLICATIONS

- Sealing of doors, lids and other constructions against water, dust and noise

ASSEMBLY

- Press into profile groove

COVER PROFILE 30

Part no.

22.1185/0

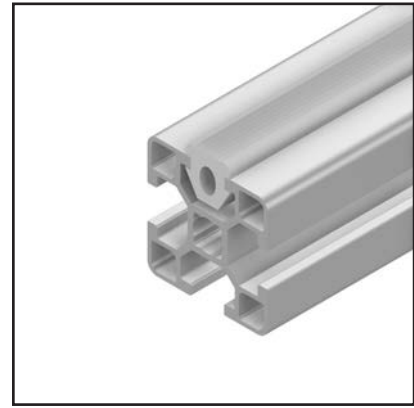
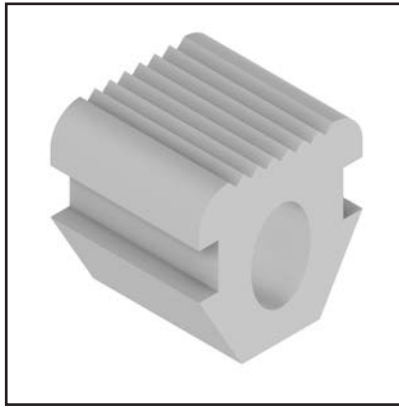
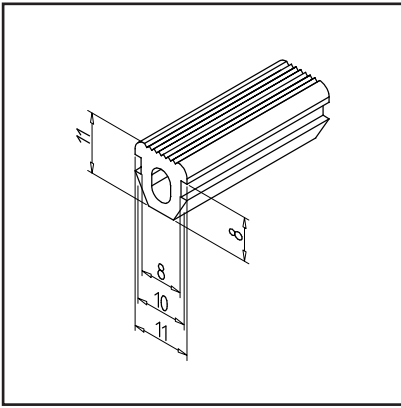

TECHN. DATA / ITEMS SUPPLIED

- EPDM, grey
- Hardness (Shore A) 70°
- Roll length 50 m
- Weight = 0.087 kg/m

APPLICATIONS

- Material shelves
- Edge Protection
- Support plates

ASSEMBLY

- Press into profile groove
- Suitable for the profiles of the profile series 30

COVER PROFILE 45

Part no.

---,---/-

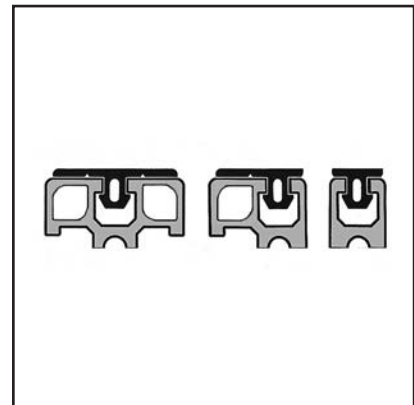
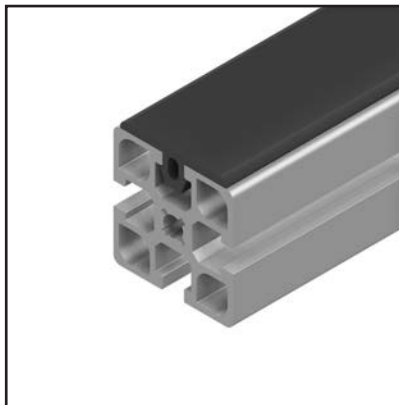
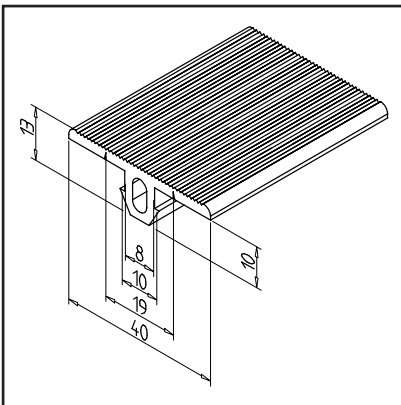

TECHN. DATA / ITEMS SUPPLIED

- Hardness (Shore A) 70°
- NBR black **part no. 22.1098/0**
- EPDM grey **part no. 22.1098/1**
- Roll length 50 m
- Weight = 0.230 kg/m

APPLICATIONS

- Edge Protection
- Safety requirement step
- Ladders
- Material shelves

ASSEMBLY

- Press into profile groove
- The lower side of the profile has 2 tear-off notches for adjustment of width to the aluminium profile

SLIDE BAR 8 N 30

Part no.

22.1170/0

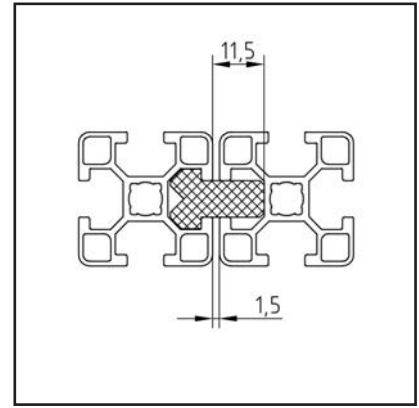
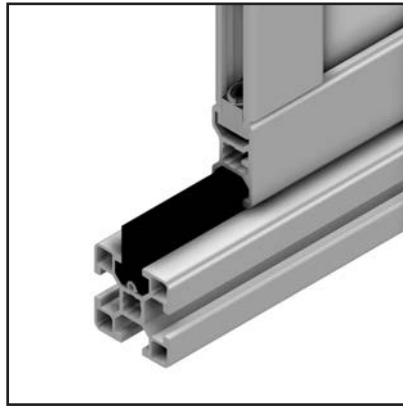
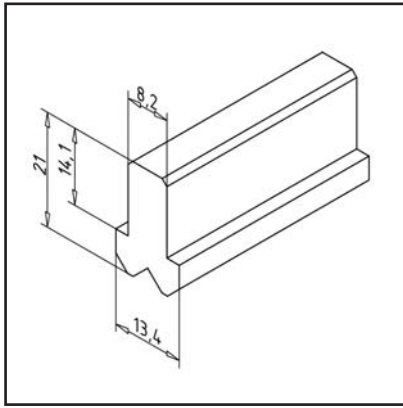

TECHN. DATA / ITEMS SUPPLIED

- PE-UHMW, black
- Highly wear-resistant
- Weight = 0.178 kg/m
- Bar length = 2 m

APPLICATIONS

- Guiding sliding doors, pull-outs, fixtures

ASSEMBLY

- Slide into profile groove
- The slide rail can be fixed on request with a threaded pin M4
- To reduce friction in moving parts, we recommend using the slide rail in short pieces with a maximum length of 100 mm.

SLIDE BAR 8 N 45

Part no.

22.1085/0

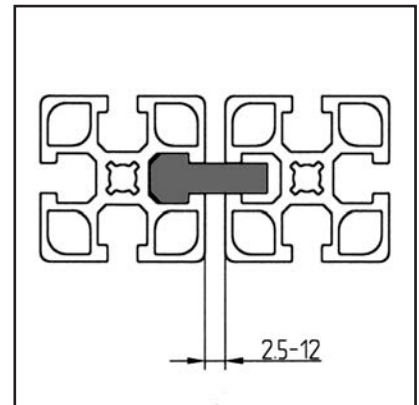
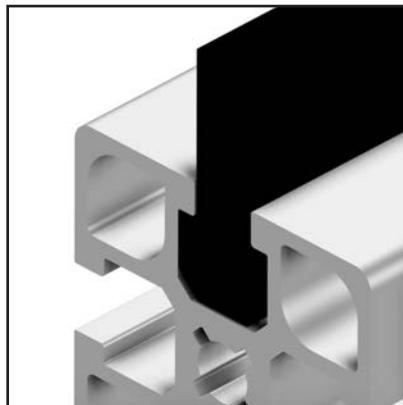
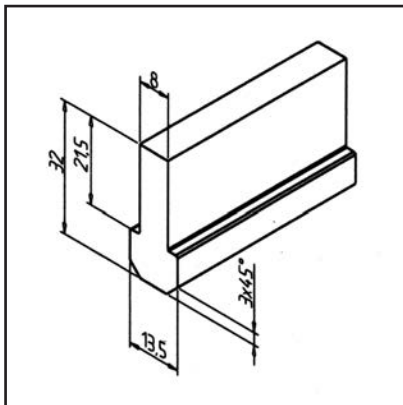

TECHN. DATA / ITEMS SUPPLIED

- PE-UHMW, black
- Highly wear-resistant
- Weight = 0.300 kg/m
- Bar length = 2 m

APPLICATIONS

- Guiding sliding doors, pull-outs, fixtures
- Lateral guide for conveyors

ASSEMBLY

- Slide into profile groove
- To reduce friction in moving parts, we recommend using the slide rail in short pieces with a maximum length of 100 mm.

SLIDE RAIL 8-40 A

Part no.

29.8012/0

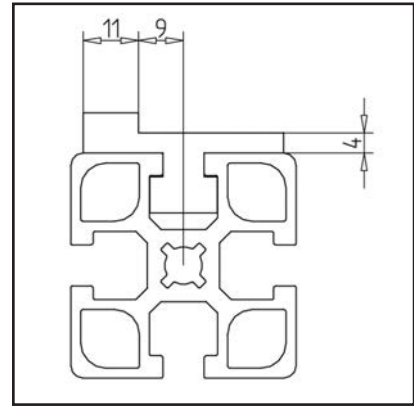
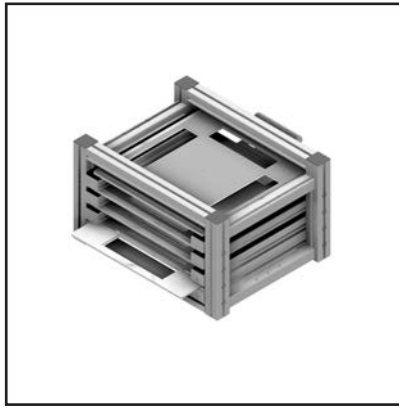
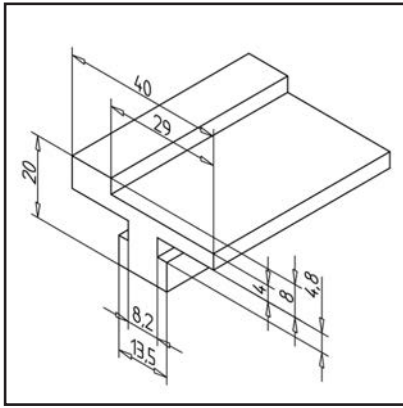

TECHN. DATA / ITEMS SUPPLIED

- PE-UHMW, black
- Highly wear-resistant
- Weight = 0.317 kg/m
- Bar length = 2 m

APPLICATIONS

- Sliding support
- Workpiece bearing
- Guide for lifting doors
- Slides

ASSEMBLY

- Slide into profile groove
- To reduce friction in moving parts, we recommend using the slide rail in short pieces with a maximum length of 100 mm.

SLIDE RAIL 8

Part no.

---/--/-

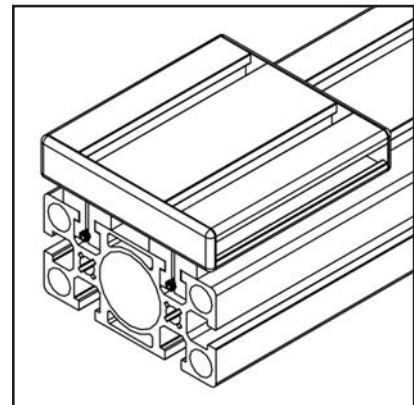
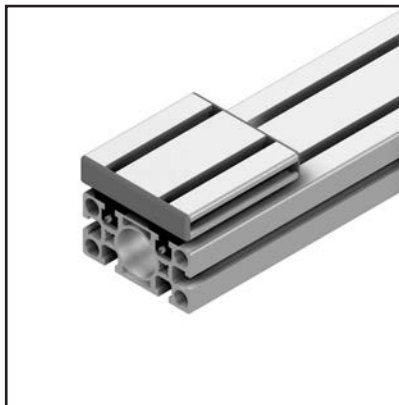
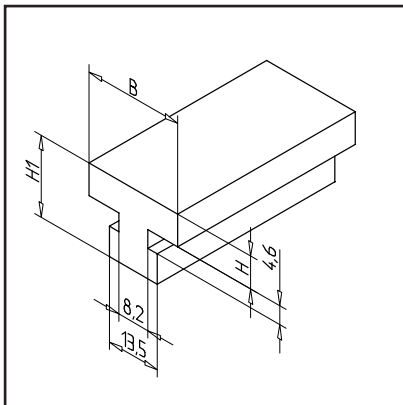

TECHN. DATA / ITEMS SUPPLIED

- PE-UHMW, black
- Highly wear-resistant
- B = 25 mm part no. **22.1088/0**
H = 7,5 mm, H1 = 20 mm
Weight 0,314 kg/m
- B = 40 mm part no. **22.1088/1**
H = 8 mm, H1 = 18 mm
Weight 0,400 kg/m
- B = 45 mm part no. **22.1088/3**
H = 8 mm, H1 = 18 mm
Weight 0,463 kg/m
- Bar length = 2 m

APPLICATIONS

- Sliding support
- Workpiece bearing
- Guide for lifting doors
- Slides

ASSEMBLY

- Slide into profile groove
- To reduce friction in moving parts, we recommend using the slide rail in short pieces with a maximum length of 100 mm.

SLIDE RAIL 23

Part no.

22.1089/0

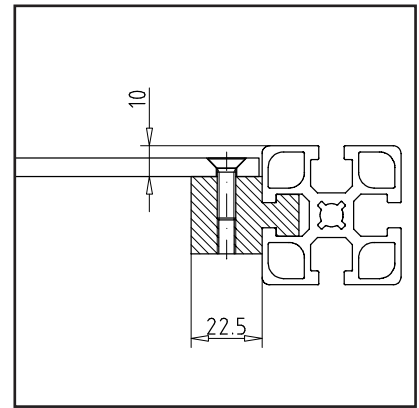
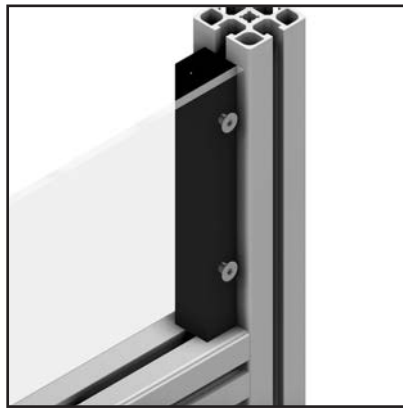
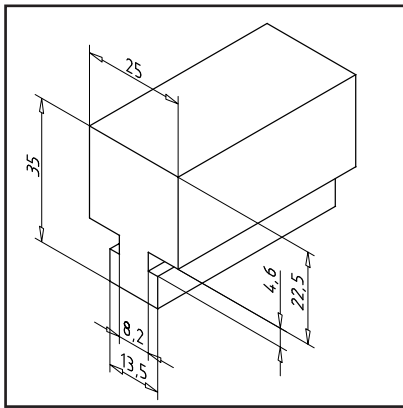

TECHN. DATA / ITEMS SUPPLIED

- PE-UHMW, black
- Highly wear-resistant
- Weight = 0.670 kg/m
- Bar length = 2 m

APPLICATIONS

- Profile sled
- Slide supports, initiator holders
- Customer-friendly processing possible due to a greater addition of material

ASSEMBLY

- Slide into profile groove
- To reduce friction in moving parts, we recommend using the slide rail in short pieces with a maximum length of 100 mm.

SLIDE STRIP R

Part no.

22.1104/0

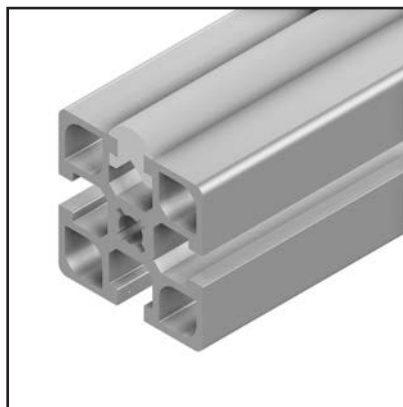
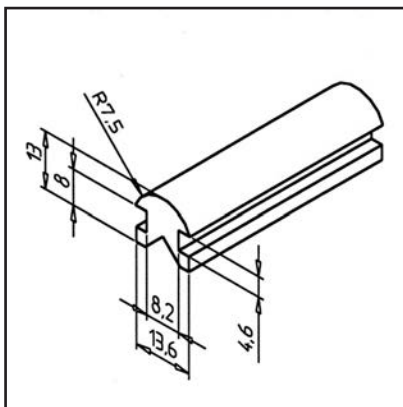

TECHN. DATA / ITEMS SUPPLIED

- PE, white
- Highly wear-resistant
- Weight = 0.115 kg/m
- Bar length = 2 m

APPLICATIONS

- Lateral guides
- Support plates
- Sliding distance
- Jam tracks

ASSEMBLY

- Slide into profile groove
- Suitable for all profiles
- secure slide strip at both ends with set screw or adjustable end caps

SLIDE STRIP F

Part no.

22.1135/0

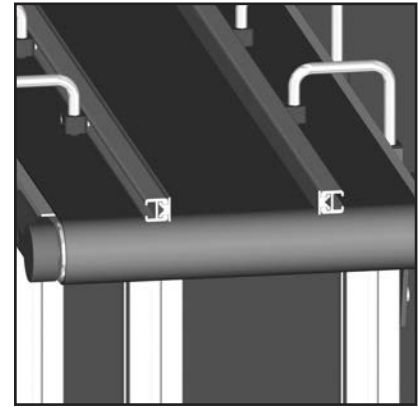
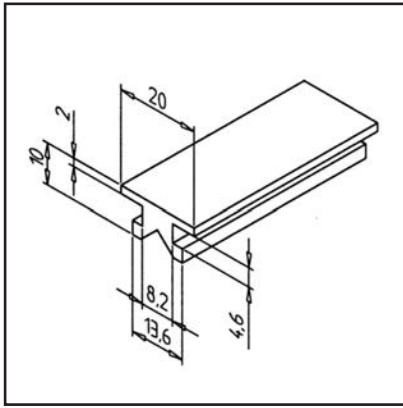

TECHN. DATA / ITEMS SUPPLIED

- PE, white
- Highly wear-resistant
- Weight = 0.098 kg/m
- Bar length = 2 m

APPLICATIONS

- lateral guide for flat components
- slide for containers
- jam tracks

ASSEMBLY

- Slide into profile groove
- Suitable for all profiles
- secure slide strip at both ends with set screw or adjustable end caps

ANGULAR SLIDE RAIL 30

Part no.

22.1171/0

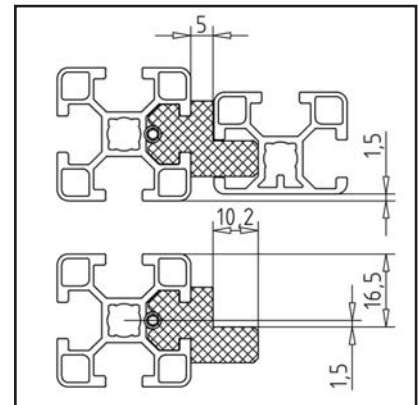
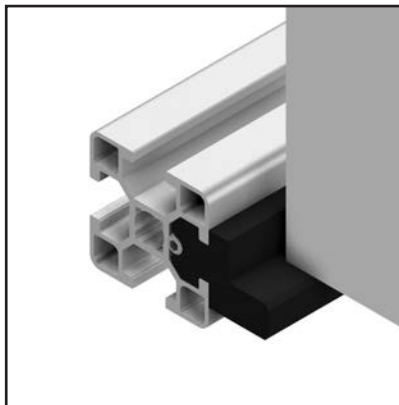
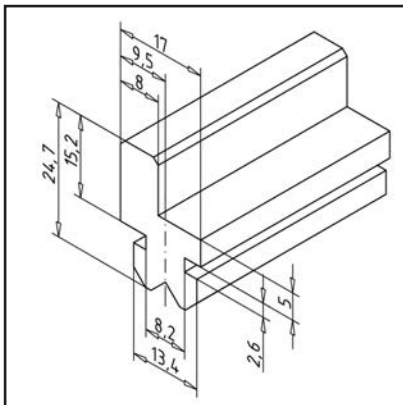

TECHN. DATA / ITEMS SUPPLIED

- PE-UHMW, black
- Highly wear-resistant
- Weight = 0.248 kg/m
- Bar length = 2 m

APPLICATIONS

- Guiding sliding doors, pull-outs, fixtures

ASSEMBLY

- Slide into profile groove
- The slide rail can be fixed on request with a threaded pin M4
- To reduce friction in moving parts, we recommend using the slide rail in short pieces with a maximum length of 100 mm.

ANGULAR SLIDE RAIL 45

Part no.

22.1040/0

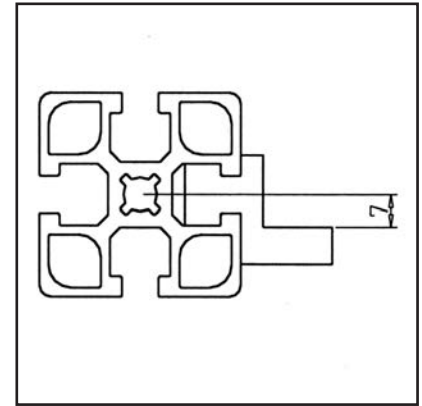
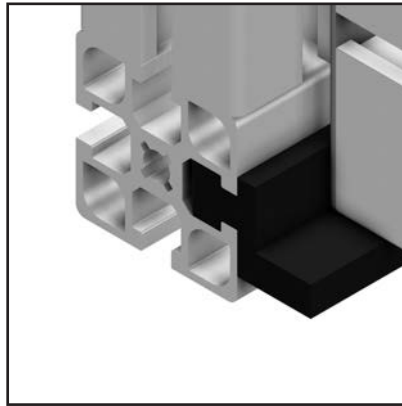
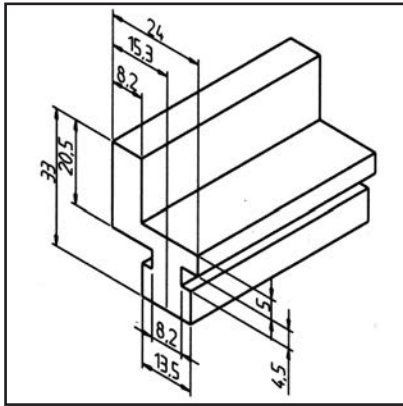

TECHN. DATA / ITEMS SUPPLIED

- PE-UHMW, black
- Highly wear-resistant
- Weight = 0.480 kg/m
- Bar length = 2 m

APPLICATIONS

- Conveying systems
- Belt conveyors
- Side stop in conveyor sections

ASSEMBLY

- Insert in profile groove and if necessary with grub screw M6 x 16 **part no. 21.1324/0** secure.
- To reduce friction in moving parts, we recommend using the slide rail in short pieces with a maximum length of 100 mm.

DOUBLE SLIDE RAIL

Part no.

22.1087/0

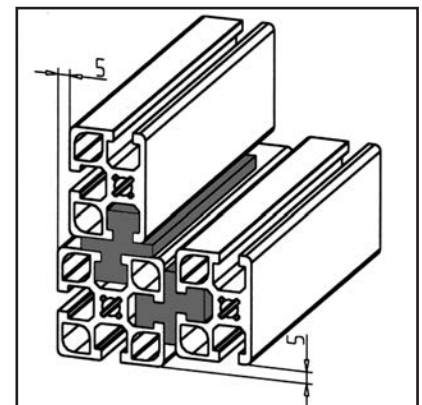
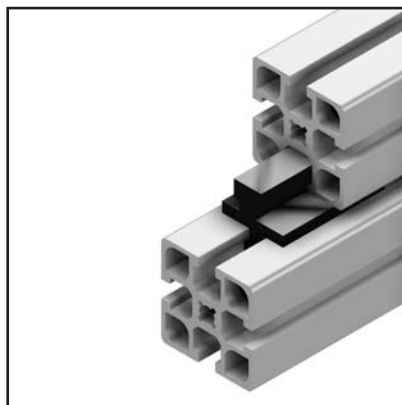
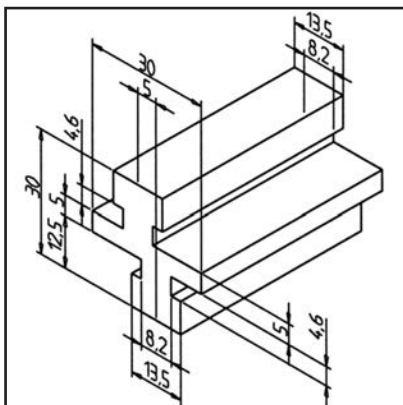

TECHN. DATA / ITEMS SUPPLIED

- PE-UHMW, black
- Highly wear-resistant
- Weight = 0.420 kg/m
- Bar length = 2 m

APPLICATIONS

- Simple workpiece slides
- Guiding drawers in profile grooves

ASSEMBLY

- Slide into profile grooves of frame and drawers
- Secure drawers against falling out by cylinder screws M8 x 16 **part no. 21.1200/0** at both ends of the frame profile
- To reduce friction in moving parts, we recommend using the slide rail in short pieces with a maximum length of 100 mm.

PARALLEL SLIDE RAIL

Part no.

22.1041/0

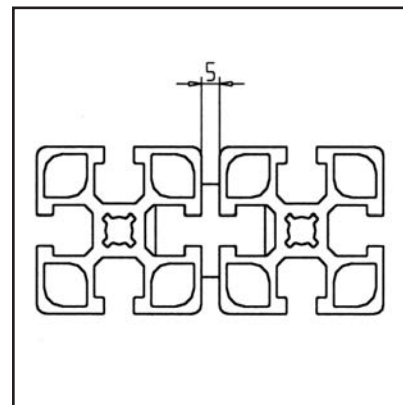
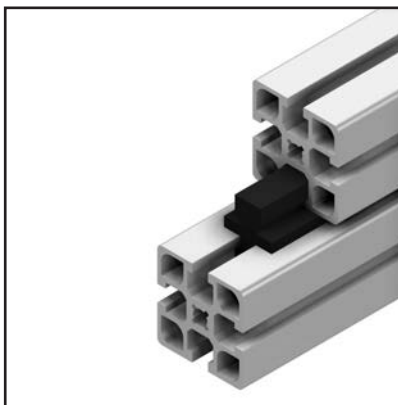
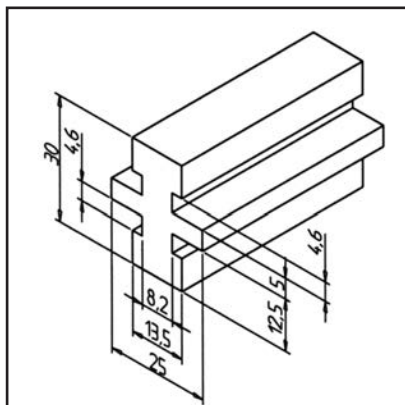

TECHN. DATA / ITEMS SUPPLIED

- PE-UHMW, black
- Highly wear-resistant
- Weight = 0.390 kg/m
- Bar length = 2 m

APPLICATIONS

- Parallel guide without difference in height
- Externally flush sliding elements

ASSEMBLY

- Slide into profile groove
- If necessary, one-sided by cylindrical pin M6 x 16 **part no. 21.1324/0** fix
- To reduce friction in moving parts, we recommend using the slide rail in short pieces with a maximum length of 100 mm.

READY-TO-INSTALL ELEMENTS FOR LIFTING AND SLIDING DOORS

All elements are already pre-assembled for you from our products. They can be very easily attached to the construction profiles with our connectors. This eliminates the need to stock individual parts and considerably shortens planning and assembly times.

**Slide-Roller element**

A lifting door requires 4 elements:

- One on each of the two columns in the upper end position.
- One on each side of the door element in the lower end position.

Length determination guide column: Stroke + 180 mm min.

1. Insert pre-assembled slide roller element in profile groove
2. Fasten in the desired position with Allen wrench SW4
3. Tighten self-locking screws with Allen wrench SW2.5

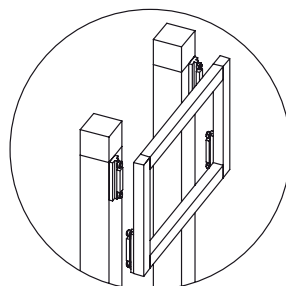

Installation possibility in front of the door pillars
Gap width = 8 mm

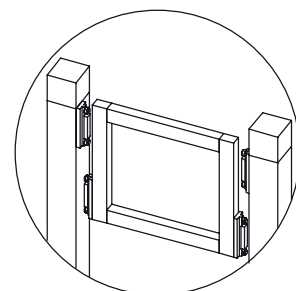

Installation possibility between the door pillars
gap width = 8 mm

CABLE PULLEY 45

Part no.

21.1775/0

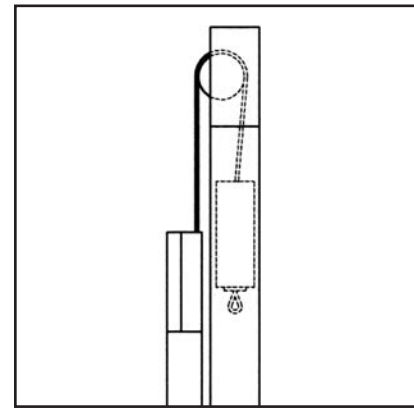
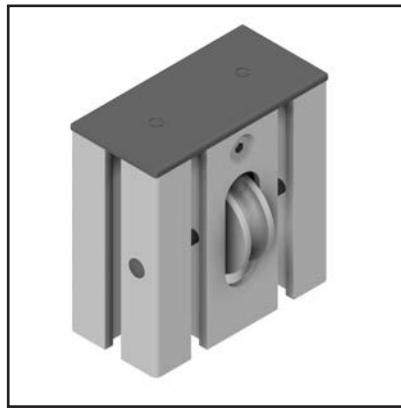
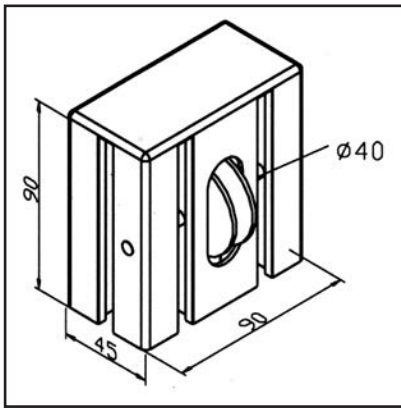

TECHN. DATA / ITEMS SUPPLIED

- Aluminium, anodized E6/EV1
- Housing from profile 45 x 90
- Pulley steel, galvanized, ready for installation
- End cap
- maximum weight of the lifting door with paired insertion of the pulley, 12kg
- Weight = 0.522 kg/piece

APPLICATIONS

- Chain reverse unit of counterweights on lifting doors, for internal compensation weight in profile 45 x 90 L or 45 x 90 G
- For continuous movement and larger loads use >12 Kg chain redirector 45

ASSEMBLY

- Attachment to the stand profile with 2 terminal strips 90 **part no. 21.1029/0**
- Associated rope **part no. 21.1777/0** is consumable and must be checked regularly and lubricated if necessary

CABLE PULLEY 90

Part no.

21.1776/0

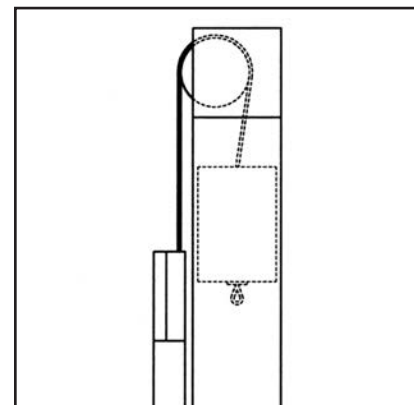
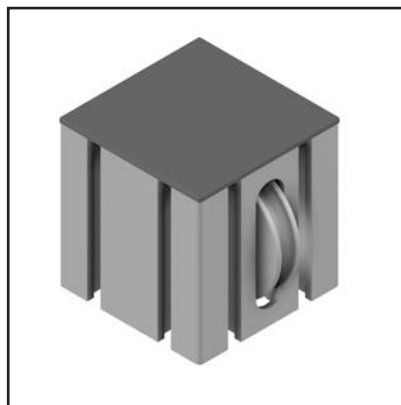
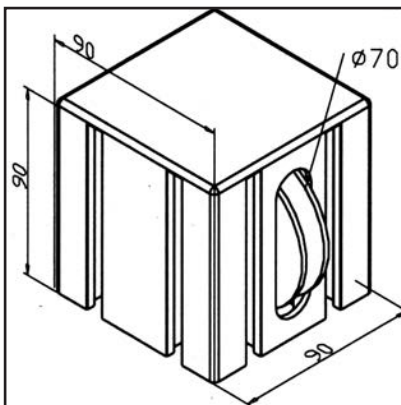

TECHN. DATA / ITEMS SUPPLIED

- Aluminium, anodized E6/EV1
- Housing from profile 90 x 90
- Pulley steel, galvanized, ready for installation
- End cap
- maximum weight of the lifting door with paired insertion of the pulley, 30kg
- Weight = 0.680 kg/piece

APPLICATIONS

- Chain reverse unit of counterweights on lifting doors, for internal compensation weight in profile 90 x 90 L
- For continuous movement and loads use >30 Kg chain redirector 90

ASSEMBLY

- Attachment to the stand profile with 4 terminal strips 90 **part no. 21.1029/0**
- Associated rope **part no. 21.1777/0** is consumable and must be checked regularly and lubricated if necessary

HAND PROTECTION

Part no.

21.1780/0

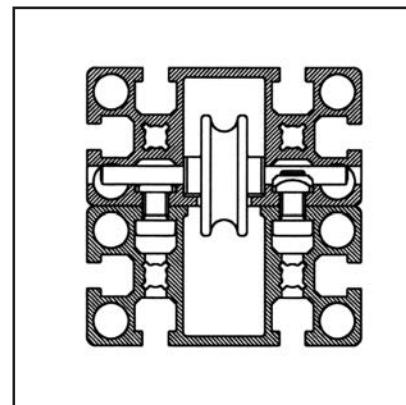
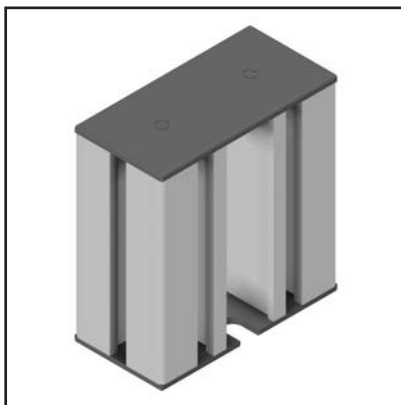
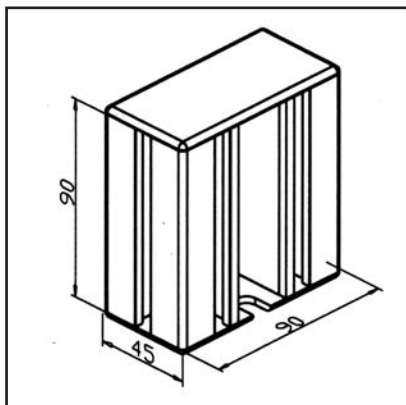
**TECHN. DATA / ITEMS SUPPLIED**

- Aluminium, anodized E6/EV1
- With fastening nut steel, galvanized
- From profile 45 x 90
- Matching caps, one of them with recess for cable or chain passage
- Length 90 mm
- Weight = 0.290 kg/piece

APPLICATIONS

- Securing from squeezing points in the area of the cable or chain inlet

ASSEMBLY

- Mount with supplied hardware

CABLE FOR COUNTERWEIGHT

Part no.

21.1777/0

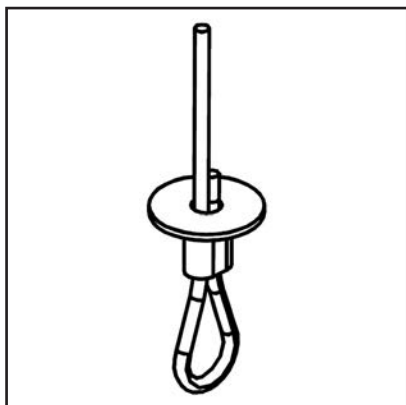
**TECHN. DATA / ITEMS SUPPLIED**

- Steel cable VA, 2,5 mm
- With clamping eye hook on one side, pressed
- **On request also deliverable in other lengths**
- Standard length 2.5 m
- Weight = 0.070 kg/piece

APPLICATIONS

- Use in connection with counterweight 45 or 90 and cable pulley

ASSEMBLY

- Lead the cable through the center bore and into the counterweight
- Rope with rope clamp **part no. 21.1797/0** fasten to lifting door
- Cable is a wear part and must be regularly checked and lubricated if required

CABLE CLAMP

Part no.

21.1797/0

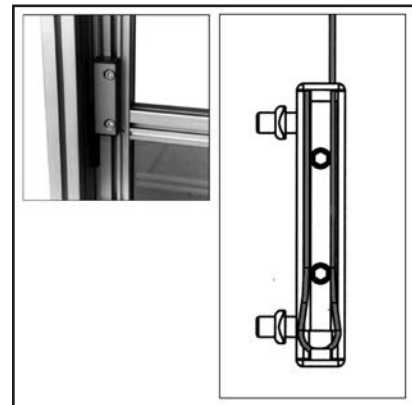
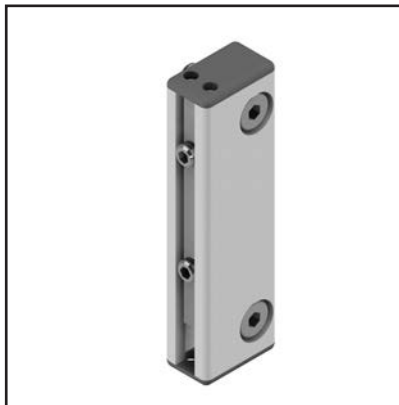
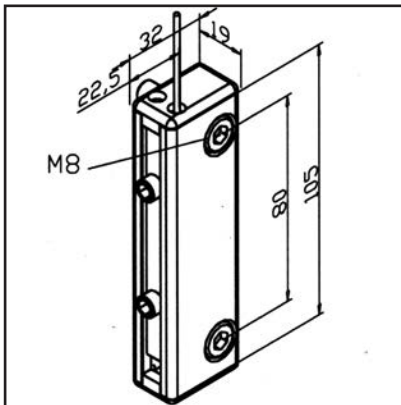

TECHN. DATA / ITEMS SUPPLIED

- Aluminium, anodized E6/EV1
- From profile 19 x 32
- 1 Clamping plate
- 2 hex socket cap screws with square nuts
- 2 suitable end caps, one of them bored
- Weight = 0.150 kg/piece

APPLICATIONS

- Fixing the wire cable **part no. 21.1777/0** on the door element of a lifting door

ASSEMBLY

- Remove the lower end cap
- Attach rope clamp with fastening kit at the top of the door element
- Pull the rope through the bore of the upper end cap
- Adjust balance weight to desired position
- Place the cable end around the clamping bar in the loop, insert it into the groove of the cable clamp and secure with a threaded pin
- If necessary, shorten the projecting end of the rope and replace the removed cap

SYNCHRONOUS REVERSE UNIT 45

Part no.

21.1792/0

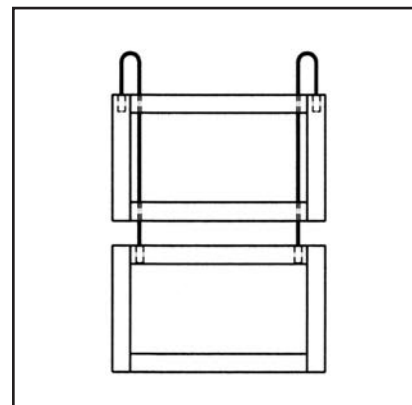
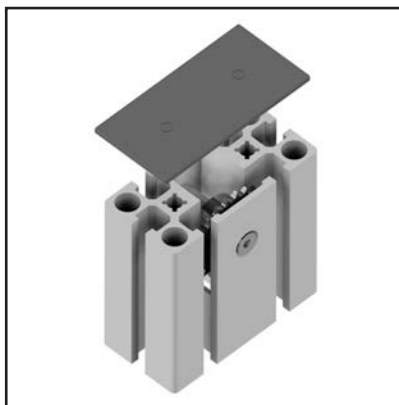
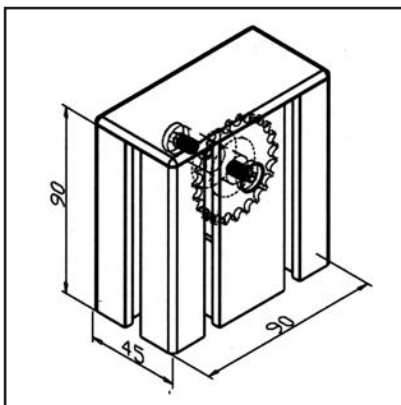

TECHN. DATA / ITEMS SUPPLIED

- Aluminium, anodized E6/EV1
- Housing from profile 45 x 90
- Sprocket galvanized steel, ready for installation
- maximum weight of the lifting door with paired insertion of the pulley, 34kg
- Weight = 0.340 kg/piece

APPLICATIONS

- Simultaneous opening and closing of two lifting doors running in the operate direction; doors are of similar weight
- Post preferably aus profile 45x90 or 90x90. The side profiles of the doors preferably made of profile 90x32 or 45x90 guided by sliding roll element in the post.

ASSEMBLY

- Attachment to the stand profile with 2 terminal strips 90 **part no. 21.1029/0**
- Chain 04 **part no. 21.1713/0** insert in diversion, with chain clamping door **part no. 21.1712/0** attach to the two doors and insert in the stand profiles
- Chain is guided in the profile groove, thus no hand-protection is required

CHAIN PULLEY 32

Part no.

21.1774/0

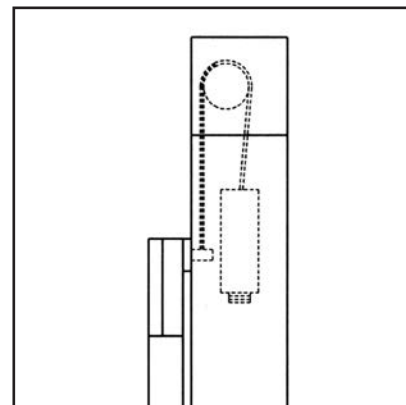
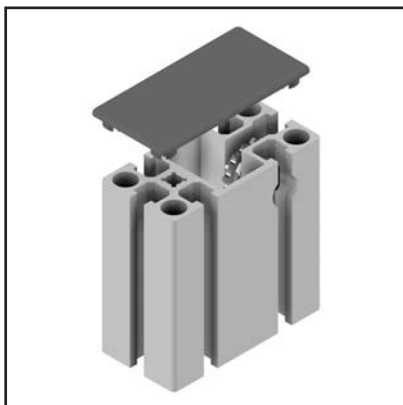
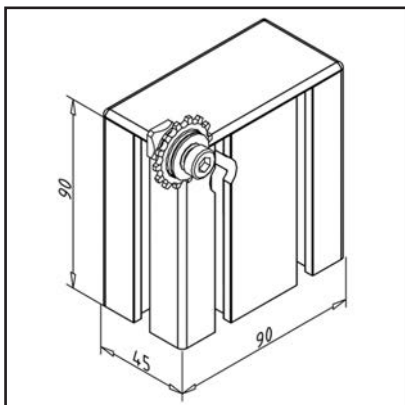

TECHN. DATA / ITEMS SUPPLIED

- Aluminium, anodized E6/EV1
- Housing from profile 45 x 90
- Sprocket galvanized steel, ready for installation
- End cap
- maximum weight of the lifting door with paired insertion of the pulley, 50kg
- Weight = 0.388 kg/piece

APPLICATIONS

- Chain reverse unit of counterweights on lifting doors, for internal compensation weight in profile 45 x 90 F or 45 x 90 G

ASSEMBLY

- Attachment to the stand profile with 2 terminal strips 90 **part no. 21.1029/0**
- Use of chain 04 **part no. 21.1712/0** and chain clamping weight **part no. 21.1711/0**
- The cable is guided in the profile groove, thus no hand-protection is required

CHAIN PULLEY 45 A

Part no.

21.1838/0

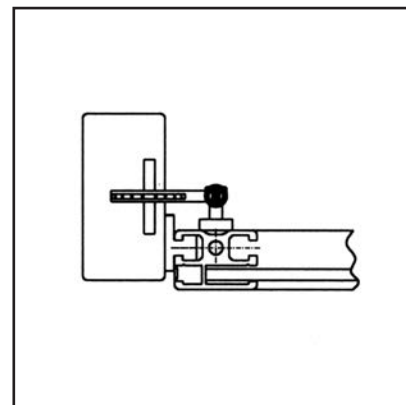
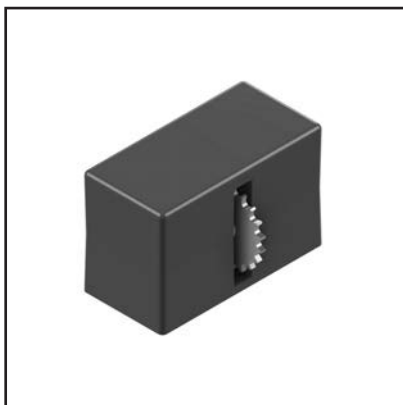
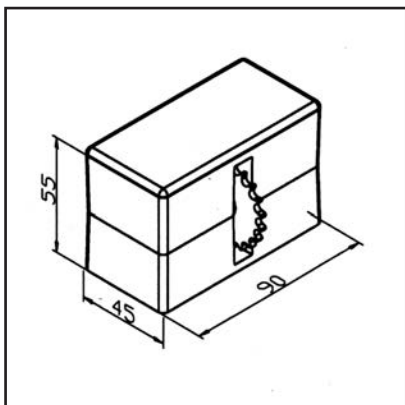

TECHN. DATA / ITEMS SUPPLIED

- Aluminium, Pressure die-casting, powder-coated, grey
- Sprocket galvanized steel, ready for installation
- End cap
- With fastening material steel, zinc plated
- maximum weight of the lifting door with paired insertion of the pulley, 50kg
- Weight = 0.350 kg/piece

APPLICATIONS

- Chain reverse unit of counterweights on lifting doors, for internal compensation weight in profile 45 x 90 F or 45 x 90 G

ASSEMBLY

- Install with supplied hardware, insert thread M8 into the stand profile
- Use of chain 04 **part no. 21.1713/0** with chain clamp door **part no. 21.1712/0** and chain clamping weight **part no. 21.1711/0**
- Chain runs outside center on wide side of profile, if necessary with hand protection **part no. 21.1780/0** cover

CHAIN PULLEY 45 I

Part no. 21.1840/0

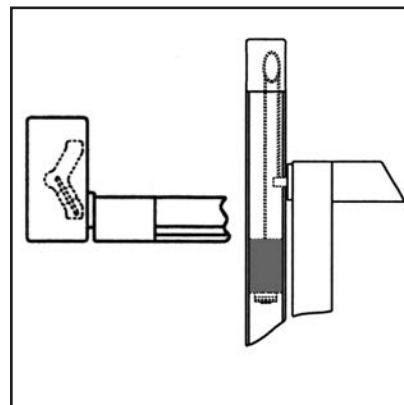
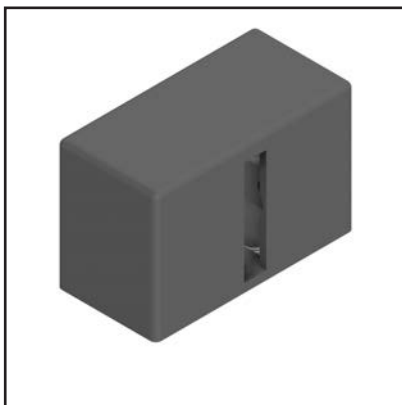
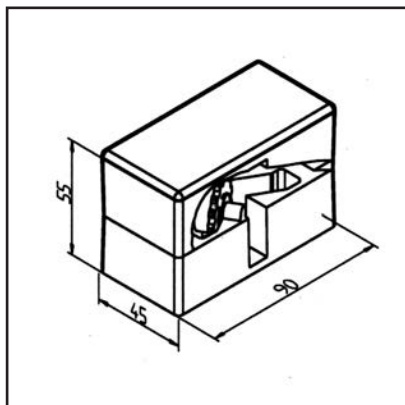

TECHN. DATA / ITEMS SUPPLIED

- Aluminium, Pressure die-casting, powder-coated, grey
- Sprocket galvanized steel, ready for installation
- End cap
- With fastening material steel, zinc plated
- maximum weight of the lifting door with paired insertion of the pulley, 50kg
- Weight = 0.350 kg/piece

APPLICATIONS

- Chain reverse unit of counterweights on lifting doors, for internal compensation weight in profile 45 x 90 F or 45 x 90 G

ASSEMBLY

- Install with supplied hardware, insert thread M8 into the stand profile
- Use of chain 04 **part no. 21.1713/0** with chain clamp door **part no. 21.1712/0** and chain clamping weight **part no. 21.1711/0**
- Chain runs on the broad side of the profile in the right or left profile groove (adjustable chain wheel), no hand-protection required

CHAIN PULLEY 90

Part no. 21.1839/0

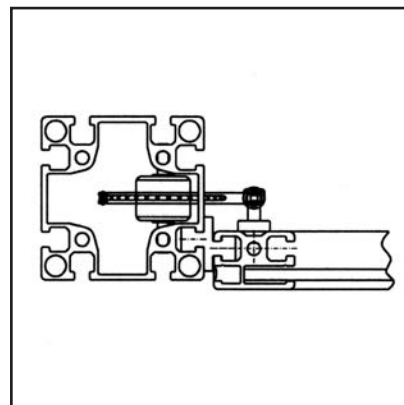
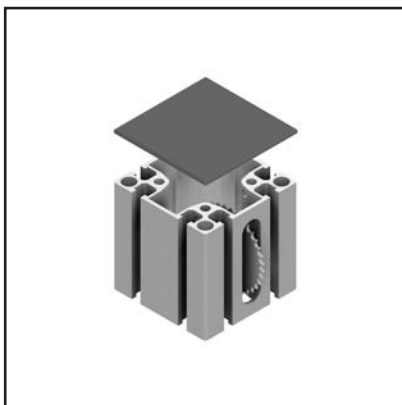
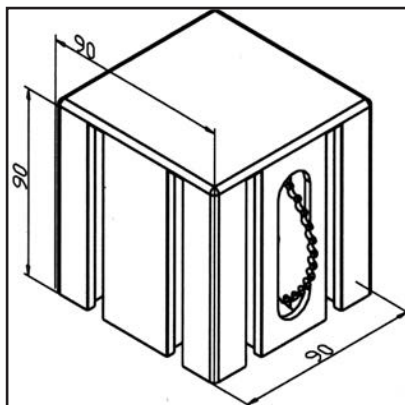

TECHN. DATA / ITEMS SUPPLIED

- Aluminium, anodized E6/EV1
- Housing from profile 90 x 90
- Sprocket galvanized steel, ready for installation
- End cap
- maximum weight of the lifting door with paired insertion of the pulley, 70kg
- Weight = 0.680 kg/piece

APPLICATIONS

- Chain reverse unit of counterweights on lifting doors, for internal balancing weight in profile 90 x 90 L

ASSEMBLY

- Attachment to the stand profile with 4 terminal strips 90 **part no. 21.1029/0**
- Use of chain 04 **part no. 21.1713/0** with chain clamp door **part no. 21.1712/0** and chain clamping weight **part no. 21.1711/0**
- Chain runs outside center on profile surface, if necessary with hand protection **part no. 21.1780/0** cover

CHAIN 04

Part no.

21.1713/0

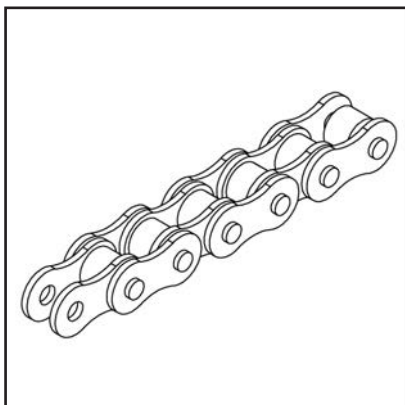
**TECHN. DATA / ITEMS SUPPLIED**

- Steel
- Size 4
- **Please indicate desired length**
- Breaking force min. 3000N
- Weight = 0.150 kg/m

**APPLICATIONS**

- Use in conjunction with balancing weight 45 or 90 and chain reverse unit.
- Use in conjunction with chain clamping door **part no. 21.1712/0** for attaching the chain to the door side
- Use in conjunction with chain clamp weight **part no. 21.1711/0** for attaching the chain to the balance weight

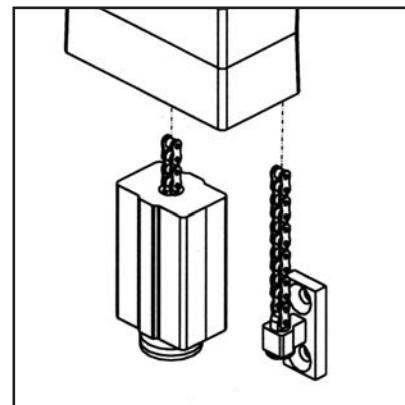
**ASSEMBLY**

- Guide the chain through the balance weight and guide the chain clamp to the weight **part no. 21.1711/0** and install the chain lock
- When mounted on door, chain by mounted chain clamp door **part no. 21.1712/0** and install bolt with chain lock

DOOR CHAIN CLAMPING DEVICE

Part no.

21.1712/0

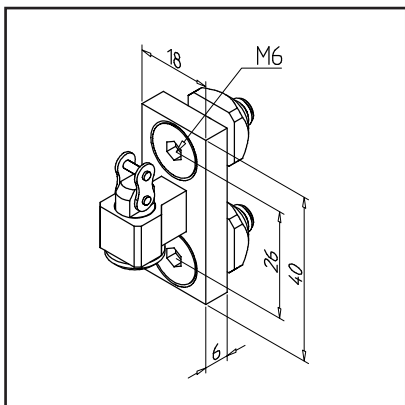
**TECHN. DATA / ITEMS SUPPLIED**

- Steel, galvanized
- With fastening material steel, zinc plated
- Weight = 0.060 kg/piece

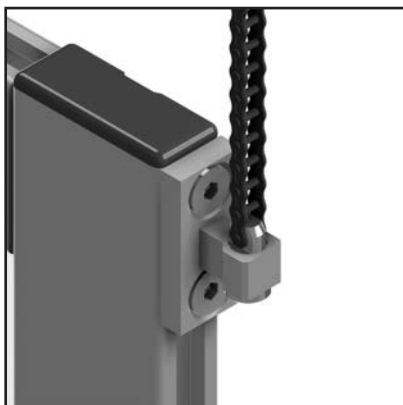
**APPLICATIONS**

- Use in conjunction with balancing weight 45 or 90 and chain reverse unit.
- Use in conjunction with chain 04 **part no. 21.1713/0** for fixing to door side

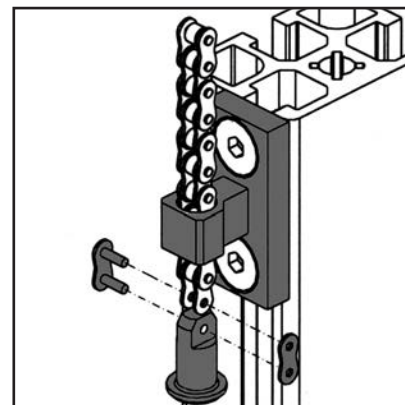
**ASSEMBLY**

- Guide the chain through the balance weight and guide the chain clamp to the weight **part no. 21.1711/0** and install the chain lock
- When mounted on door, chain by mounted chain clamp door **part no. 21.1712/0** and install bolt with chain lock
- When making lift doors, where the chain is guided in the groove, we recommend the use of our sliding roller element **part no. 21.1796/0**. Here is a door gap to the post of 8 mm provided.

DOOR CHAIN CLAMPING DEVICE KV-32

Part no.

21.1980/0

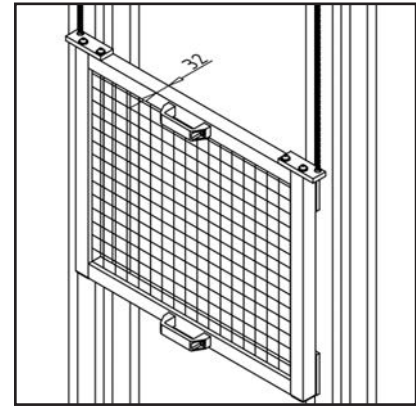
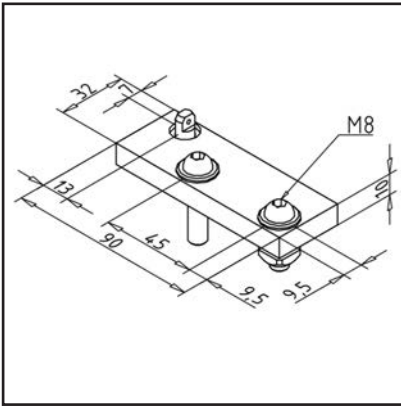

TECHN. DATA / ITEMS SUPPLIED

- Steel, galvanized
- With fastening material and chain lock
- Weight = 0.247 kg/piece

APPLICATIONS

- Use in connection with chain pulley 90 and chain 04
- Lifting plate made of profile 45x32 with sliding roller mounted in front of the posts

ASSEMBLY

- Mount plate on lifting plate and secure the roller chain 04 using the supplied chain lock
- Two chain clamps are required for each lifting field

DOOR CHAIN CLAMPING DEVICE KV-45

Part no.

21.1981/0

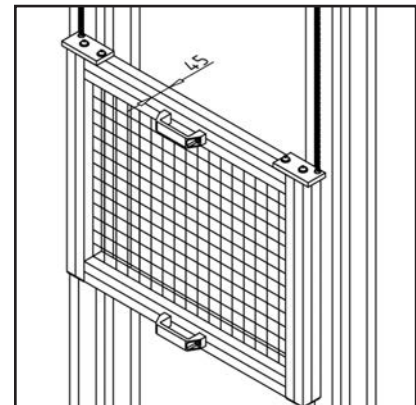
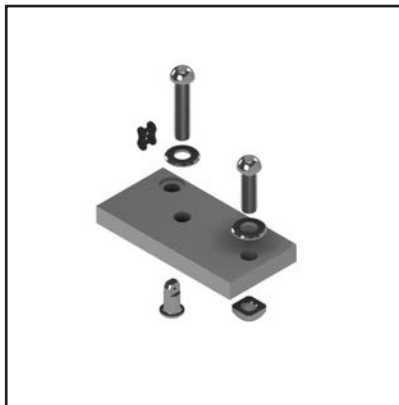
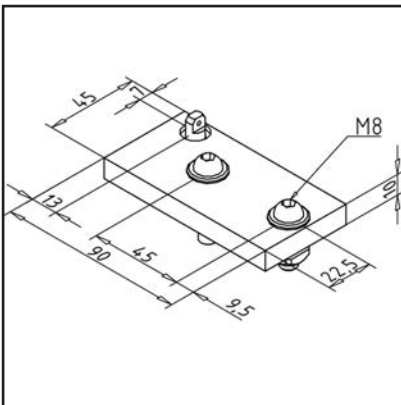

TECHN. DATA / ITEMS SUPPLIED

- Steel, galvanized
- With fastening material and chain lock
- Weight = 0.345 kg/piece

APPLICATIONS

- Use in connection with chain pulley 90 and chain 04
- Lifting plate made of profile 45x45 with sliding roller mounted in front of the posts

ASSEMBLY

- Mount plate on lifting plate and secure the roller chain 04 using the supplied chain lock
- Two chain clamps are required for each lifting field

DOOR CHAIN CLAMPING DEVICE KI-32

Part no.

21.1982/0

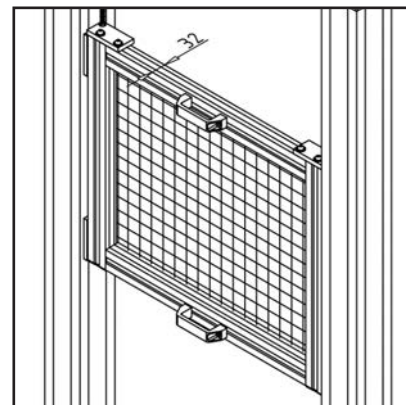
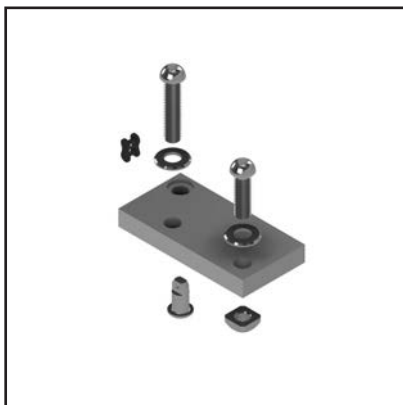
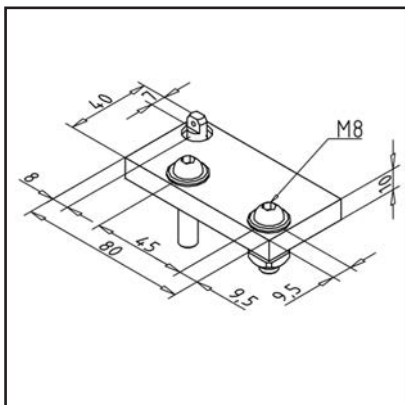

TECHN. DATA / ITEMS SUPPLIED

- Steel, galvanized
- With fastening material and chain lock
- Weight = 0.278 kg/piece

APPLICATIONS

- Use in connection with chain pulley 90 and chain 04
- Lifting plate made of profile 45x32 with sliding roller mounted between the posts

ASSEMBLY

- Mount plate on lifting plate and secure the roller chain 04 using the supplied chain lock
- Two chain clamps are required for each lifting field

DOOR CHAIN CLAMPING DEVICE KI-45

Part no.

21.1983/0

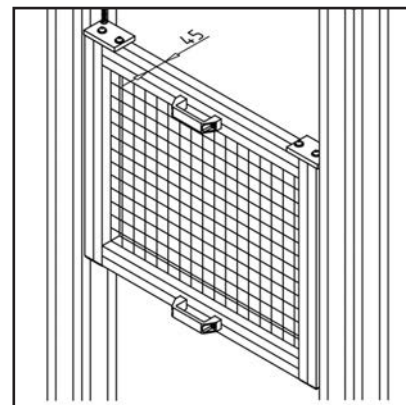
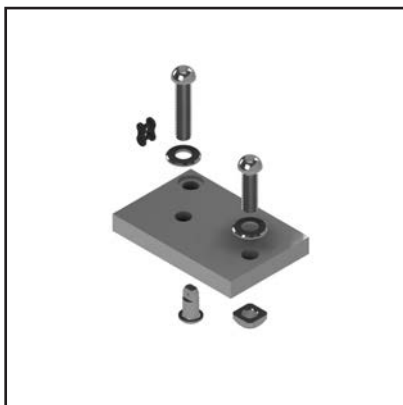
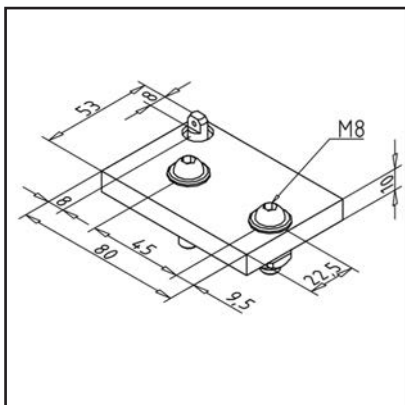

TECHN. DATA / ITEMS SUPPLIED

- Steel, galvanized
- With fastening material and chain lock
- Weight = 0.360 kg/piece

APPLICATIONS

- Use in connection with chain pulley 90 and chain 04
- Lifting plate made of profile 45x45 with sliding roller mounted between the posts

ASSEMBLY

- Mount plate on lifting plate and secure the roller chain 04 using the supplied chain lock
- Two chain clamps are required for each lifting field

CHAIN CLAMPING WEIGHT

Part no. 21.1711/0

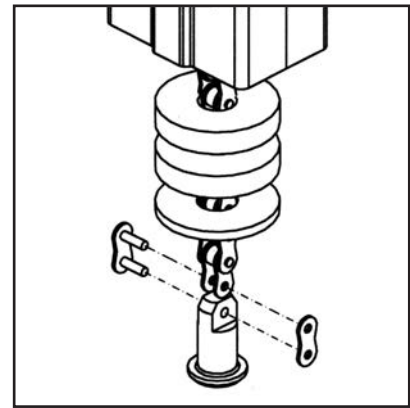
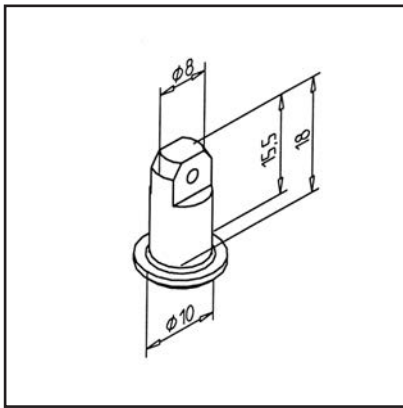

TECHN. DATA / ITEMS SUPPLIED

- Steel, galvanized
- Rubber-ring
- chain lock
- Weight = 0.015 kg/piece

APPLICATIONS

- Use in conjunction with balancing weight 45 or 90 and chain reverse unit.
- Use in conjunction with chain 04 **part no. 21.1713/0** for attaching the chain to the balance weight

ASSEMBLY

- Guide the chain through the balance weight and guide the chain clamp to the weight **part no. 21.1711/0** and install the chain lock
- When mounted on door, chain by mounted chain clamp door **part no. 21.1712/0** and install bolt with chain lock

CHAIN PULLEY 90 S

Part no. 21.0920/0

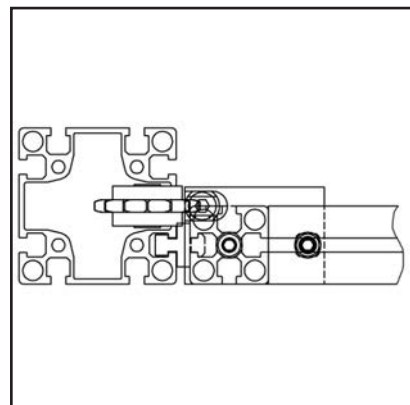
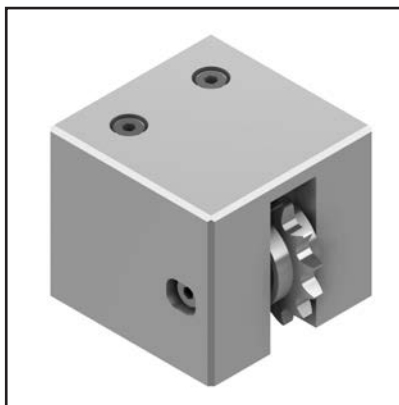
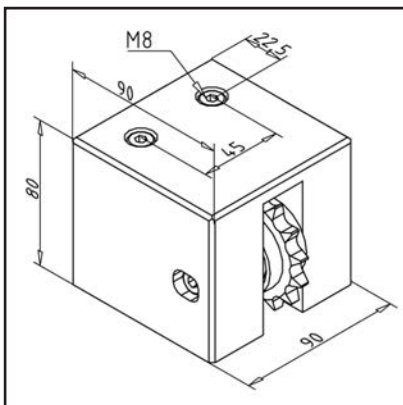

TECHN. DATA / ITEMS SUPPLIED

- Aluminium, anodized E6/EV1
- With fastening material steel, zinc plated
- maximum weight of the lifting door with paired insertion of the pulley, 150kg
- Weight = 1.748 kg/piece

APPLICATIONS

- Chain reverse unit of counterweights on lifting doors, for internal balancing weight in profile 90 x 90 L

ASSEMBLY

- Use fastening kit
- Use of chain 08 **part no. 29.0307/0**, chain clamping weight S **part no. 21.0925/0**

CHAIN 08

Part no.

29.0307/0

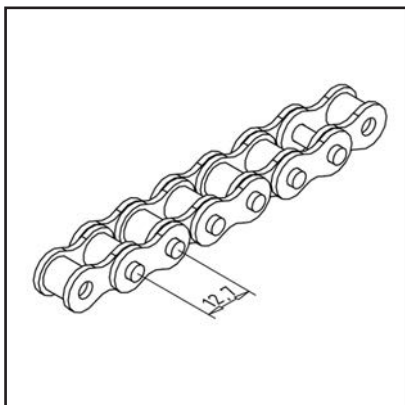
**TECHN. DATA / ITEMS SUPPLIED**

- Steel
- Size 8
- Breaking force min. 18,000 N
- **Please indicate desired length**
- Weight = 0.700 kg/m

**APPLICATIONS**

- Use in conjunction with balancing weight 45 or 90 and chain clamping 90 S
- For this chain clamping weight S **part no. 21.0925/0** use

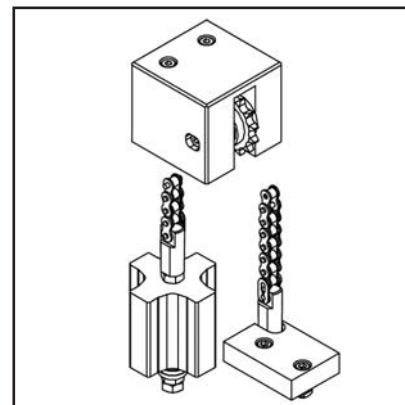
**ASSEMBLY**

- Attachment to the stand profile with 4 terminal strips Fixing with chain clamp weight S **part no. 21.0925/0** on threaded rod M10 **part no. 21.1667/0** for receiving the balance weights

DOOR CHAIN CLAMPING 90 S, AT THE FRONT

Part no.

21.0927/0

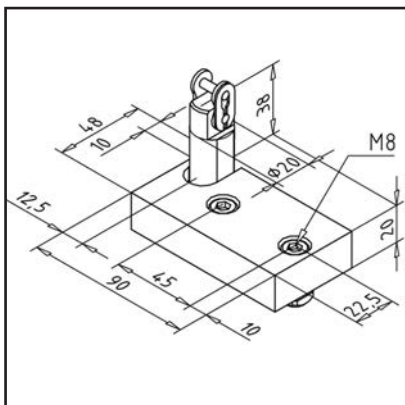
**TECHN. DATA / ITEMS SUPPLIED**

- Aluminium, anodized E6/EV1
- With fastening material and chain lock
- Weight = 0.381 kg/piece

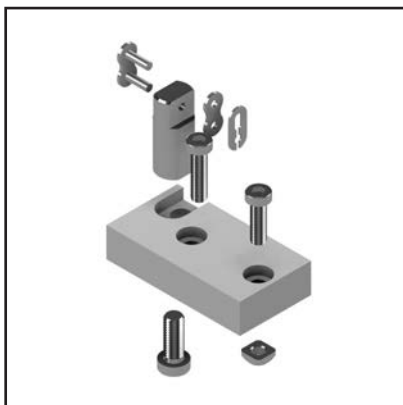
**APPLICATIONS**

- Use in conjunction with chain reverse 90 S and chain 08
- Add a lifting plate from Profile 45x45 with sliding roller in front of the posts

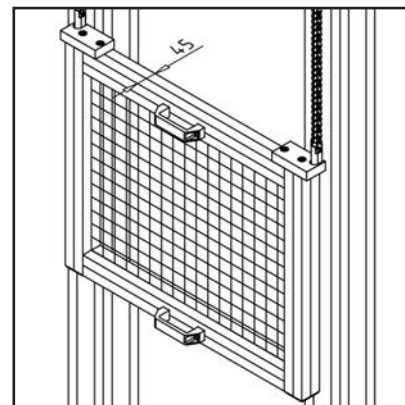
**ASSEMBLY**

- Mount plate on lifting plate and secure the roller chain 08 using the supplied chain lock
- Each lifting plate requires 2 chain reversing unit

DOOR CHAIN CLAMPING 90 S, ON THE SIDE

Part no.

21.0928/0

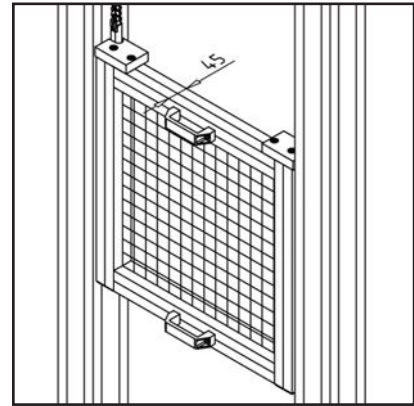
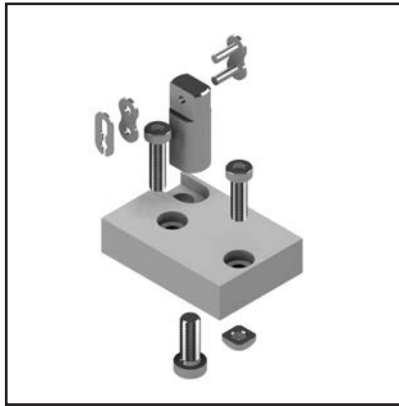
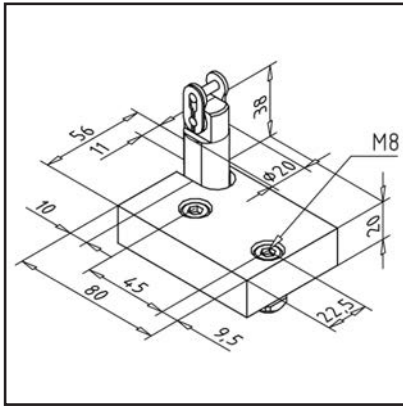

TECHN. DATA / ITEMS SUPPLIED

- Aluminium, anodized E6/EV1
- With fastening material and chain lock
- Weight = 0.368 kg/piece

APPLICATIONS

- Use in conjunction with chain reverse 90 S and chain 08
- Add a lifting plate from Profile 45x45 with sliding roller between the posts

ASSEMBLY

- Mount plate on lifting plate and secure the roller chain 08 using the supplied chain lock
- Each lifting plate requires 2 chain reversing unit

CHAIN CLAMPING 90 S CARRIAGE

Part no.

21.0929/0

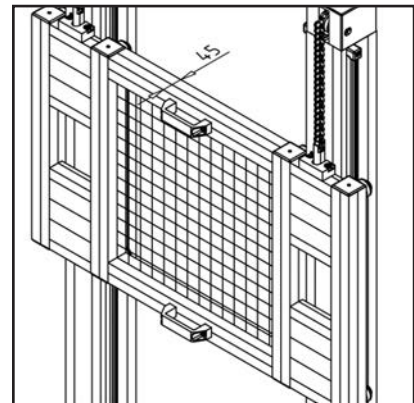
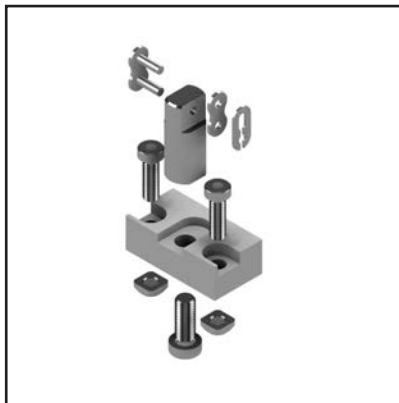
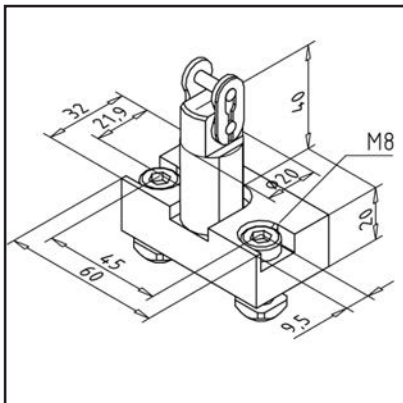

TECHN. DATA / ITEMS SUPPLIED

- Aluminium, anodized E6/EV1
- With fastening material and chain lock
- Weight = 0.375 kg/piece

APPLICATIONS

- Use in conjunction with chain reverse 90 S and chain 08
- For mounting on slide LW 45 or LW 90

ASSEMBLY

- Mount plate on carriage and secure the roller chain 08 using the supplied chain lock

CHAIN CLAMPING WEIGHT S

Part no.

21.0925/0

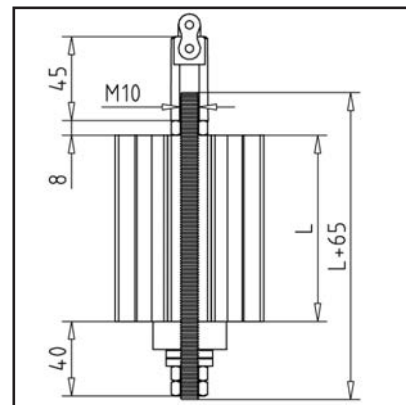
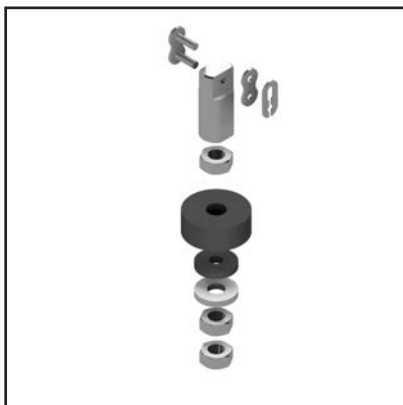
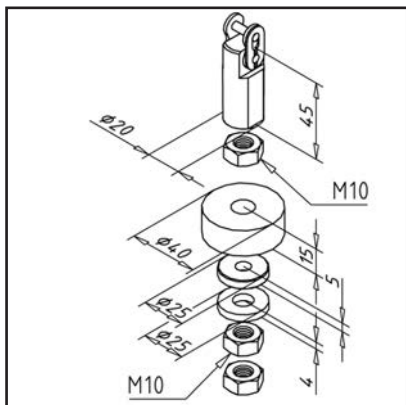

TECHN. DATA / ITEMS SUPPLIED

- Steel, galvanized
- Rubber-ring
- chain lock
- Please threaded rod M10 **part no. 21.1667/0** order additionally in the desired length
- Weight = 0.145 kg/piece

APPLICATIONS

- Use in connection with roller chain 08 and balancing weight 45 or 90
- Length of the threaded rod = length of the weight +65mm

ASSEMBLY

- Guide the threaded rod through the weight
- Attach the components included at both ends
- Connect threaded rod with enclosed chain lock chain

COUNTERWEIGHT 45

Part no.

21.1772/0

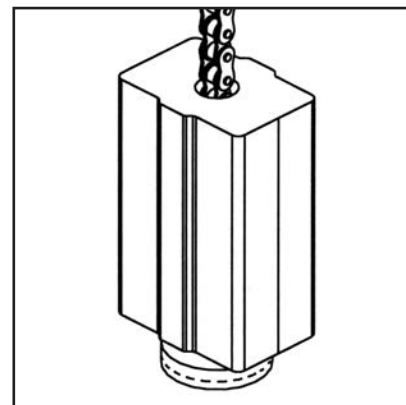
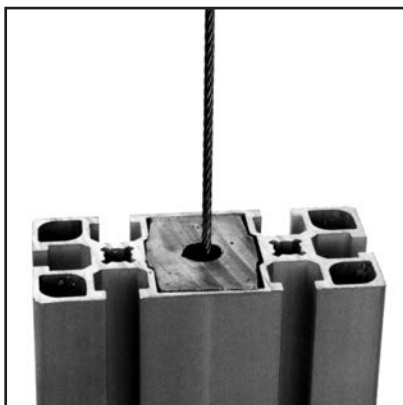
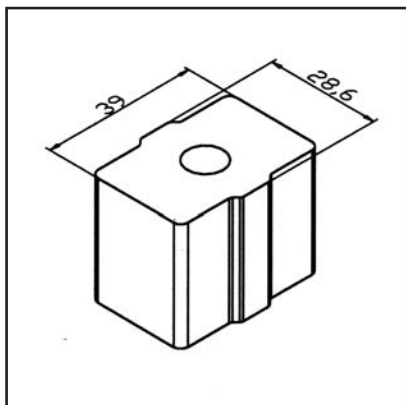

TECHN. DATA / ITEMS SUPPLIED

- Lead
- Fitting for profile 45 x 90 F or 45 x 90 G
- Length 0,330m
- Weight = 10.000 kg/m

APPLICATIONS

- Weight compensation for lightweight lifting doors
- Suitable for cable or roller chain 04 or roller chain 08

ASSEMBLY

- Set it into profile with pre-assembled cable or pre-assembled chain

COUNTERWEIGHT 90

Part no.

21.1778/0

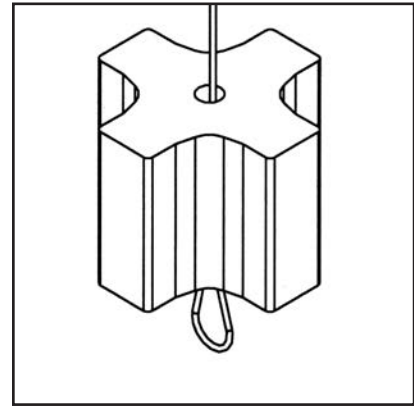
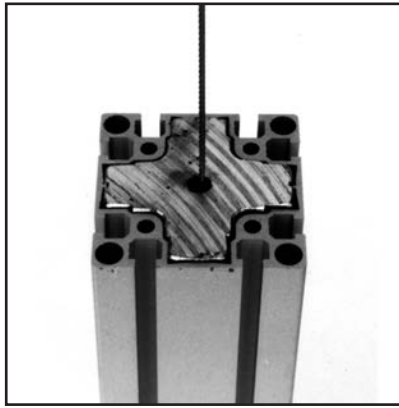
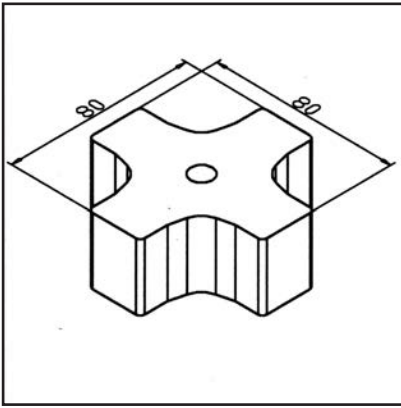

TECHN. DATA / ITEMS SUPPLIED

- Lead
- For profiles 90 x 90
- Length 0,260m
- Weight = 38.500 kg/m

APPLICATIONS

- Weight compensation for lightweight lifting doors
- Suitable for cable or roller chain 04 or roller chain 08

ASSEMBLY

- Set it into profile with pre-assembled cable or pre-assembled chain

SLIDE-ROLL ELEMENT

Part no.

21.1796/0

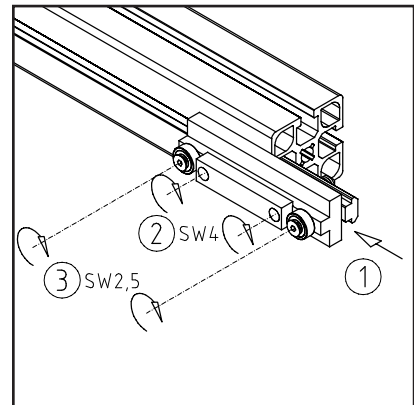
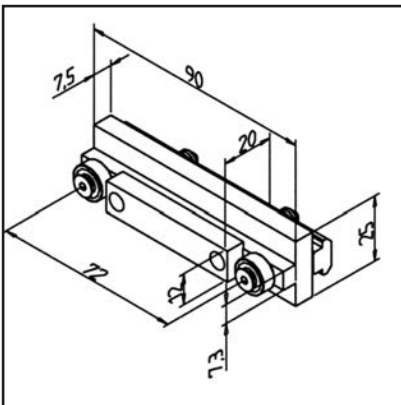

TECHN. DATA / ITEMS SUPPLIED

- PE-UHMW, black
- 1 T-slot bar, steel, zinc plated
- 2 ball bearings, pre-assembled
- Fmax. 200 N
- Weight = 0.094 kg/piece

APPLICATIONS

- Guide for lifting doors in the groove of the vertical profile
- Moving parts
- Bearing of workpieces, slides, brackets

ASSEMBLY

1. Insert pre-assembled slide roller element in profile groove
2. Fasten in the desired position with Allen wrench SW4
3. Tighten self-locking screws with Allen wrench SW2.5

GLIDE ROLL ELEMENT

Part no.

21.1799/0

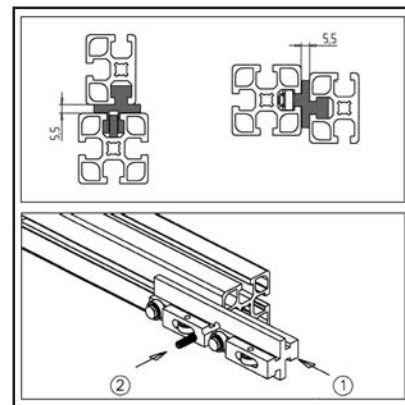
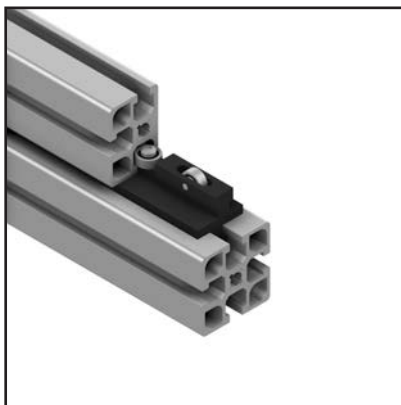
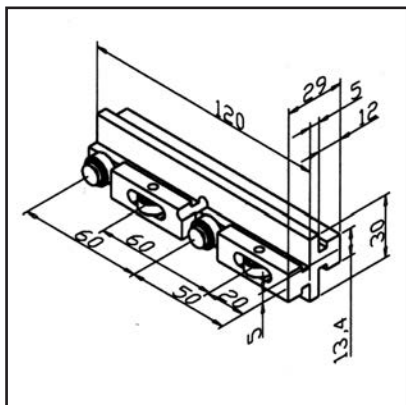
**TECHN. DATA / ITEMS SUPPLIED**

- PE-UHMW, black
- 1 clamping screw, steel, zinc plated
- 4 built-in ball-bearings
- Fmax. 300 N
- Weight = 0.061 kg/piece

APPLICATIONS

- Guide for sliding doors, lifting-doors, work-piece-slides, light linear guides
- Both groove holders are arranged in parallel, for simplify the design of flush sliding doors

ASSEMBLY

- 1: Insert the element with screw side into profile groove of movable construction part
- 2: secure with threaded pin
- 3: Slide the completely mounted movable part into the grooves of the guiding profiles. Secure the movable part against falling out with screws at both ends

GLIDE ROLL ELEMENT PARALLEL

Part no.

21.1714/0

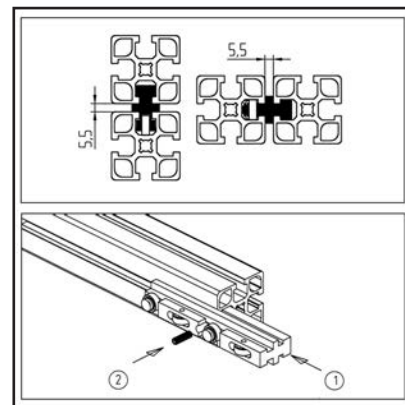
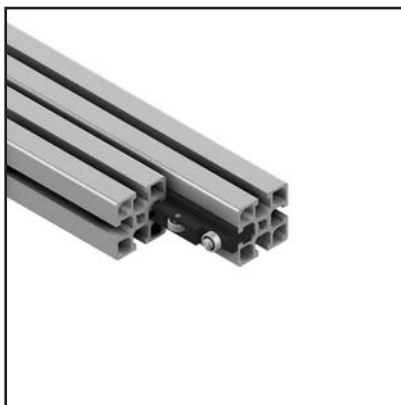
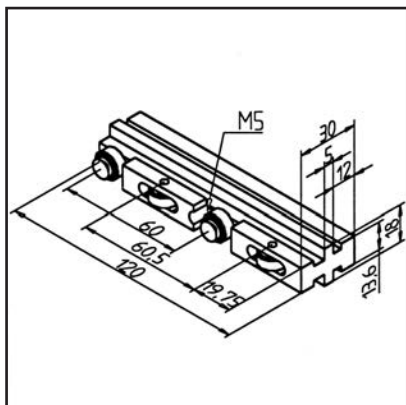
**TECHN. DATA / ITEMS SUPPLIED**

- PE-UHMW, black
- 1 clamping screw, steel, zinc plated
- 4 built-in ball-bearings
- Fmax. 300 N
- Weight = 0.055 kg/piece

APPLICATIONS

- Guide for sliding doors, lifting-doors, work-piece-slides, light linear guides
- Both groove holders are arranged in parallel, for simplify the design of flush sliding doors

ASSEMBLY

- 1: Insert the element with screw side into profile groove of movable construction part
- 2: secure with threaded pin
- 3: Slide the completely mounted movable part into the grooves of the guiding profiles. Secure the movable part against falling out with screws at both ends

SLIDE ELEMENT

Part no.

21.1795/0

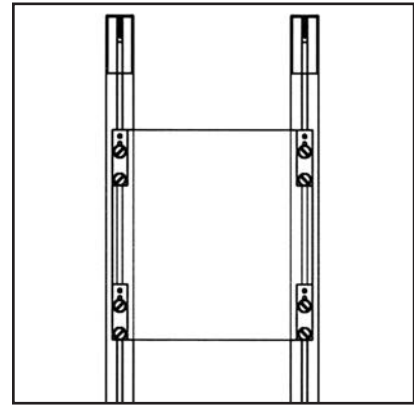
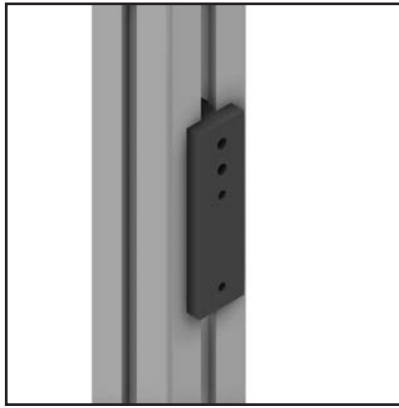
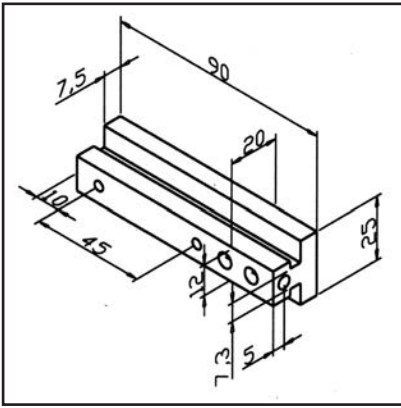

TECHN. DATA / ITEMS SUPPLIED

- PE-UHMW, black
- With fastening material steel, zinc plated
- Ready to install with cable ducting and clamping
- Weight = 0.029 kg/piece

APPLICATIONS

- Guide for lightweight lifting doors and simultaneous connection of door element and balancing weight
- Especially suitable for direct attachment on surface elements without frame

ASSEMBLY

- Connect rope of counterweight with slide tensioning element
- Secure cable end with clamp
- Screw into the groove of the vertical profile
- Screw panel element

GUIDE FOR SLIDING DOOR 30 V

Part no.

22.1184/0

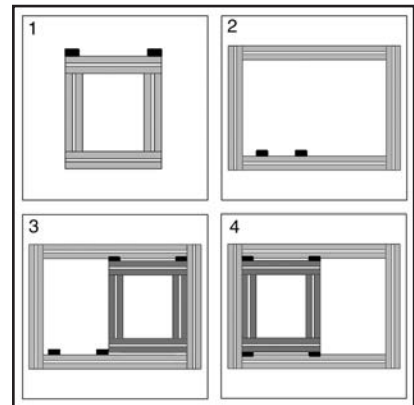
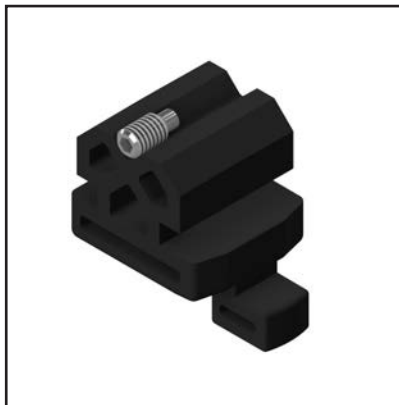
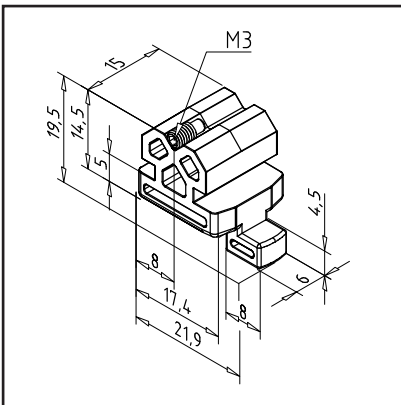

TECHN. DATA / ITEMS SUPPLIED

- PA, black
- 1 locking screw
- For 1 door element 4 guides are necessary
- Weight = 0.004 kg/piece

APPLICATIONS

- Sliding doors
- sliding elements
- For a simultaneous guidance of 2 elements in 1 profile groove
- It is possible to retrofit sliding doors in existing constructions
- For use with door elements of profile series 30
- The outer frame construction can consist of profiles of series 45 as well as of series 30

ASSEMBLY

- 1: Fasten the upper guide to the frame of the door element
 - 2: Insert the lower guide into the frame construction
 - 3: Rotate the door element
 - 4: Slide it into the lower guide and secure at desired position
- Replace the second door element
 - **Height of door elements:**
lichte Höhe der Einbauöffnung -11 mm
 - **Door element width (for 2 elements):**
(inside + 24 mm) : 2

FOLDING DOORWAY SET

Part no.

22.1148/0

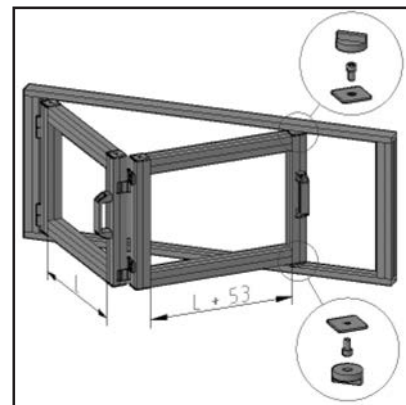
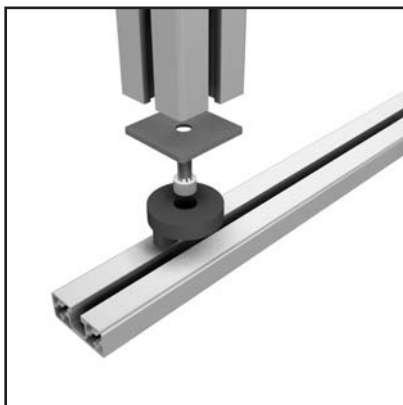
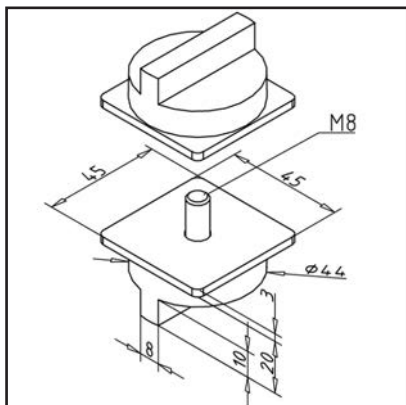

TECHN. DATA / ITEMS SUPPLIED

- PE-UHMW, black
- Delivery: 1 pair
- With galvanized mounting screws M8 and end caps 45x45 AL
- Weight = 0.082 kg/set

APPLICATIONS

- For upper and lower guidance of folding doors made of aluminium profile
- Guiding in profile grooves

ASSEMBLY

- Mount end caps onto front door profile with screws from delivery scope
- Insert sliding piece in guide profile
- Insert mounted screws into drill hole of slide element
- Use always in pairs
- Dimensions are for profile cross section 45x45 for the door with hinge **part no. 21.1378/0**

GUIDE FOR SLIDING DOOR 45

Part no.

22.1079/0

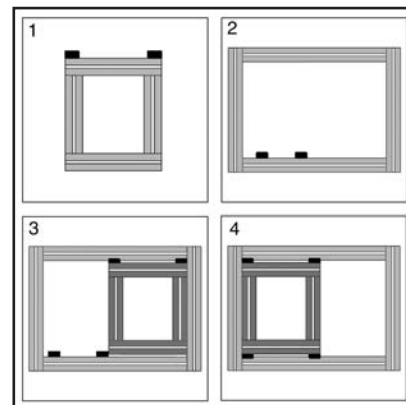
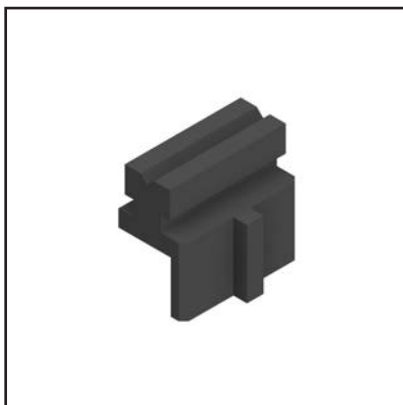
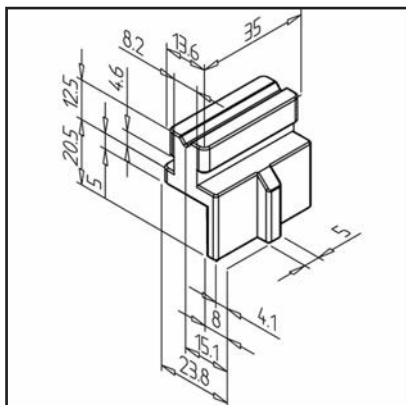

TECHN. DATA / ITEMS SUPPLIED

- PA, black
- 1 locking screw
- For 1 door element 4 guides are necessary
- Weight = 0.014 kg/piece

APPLICATIONS

- Sliding doors
- sliding elements
- For a simultaneous guidance of 2 elements in 1 profile groove
- It is possible to retrofit sliding doors in existing constructions

ASSEMBLY

- 1: Fasten the upper guide to the frame of the door element
 - 2: Insert the lower guide into the frame construction
 - 3: Rotate the door element
 - 4: Slide it into the lower guide and secure at desired position
- Replace the second door element
 - **Height of door elements:**
lichte Höhe der Einbauöffnung -11 mm
 - **Width of door elements** (with 2 elements):
(lichte Weite + 49 mm) : 2

ROLLER WHEEL

Part no. 21.1782/0

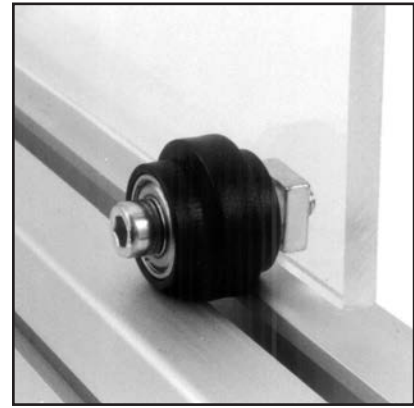
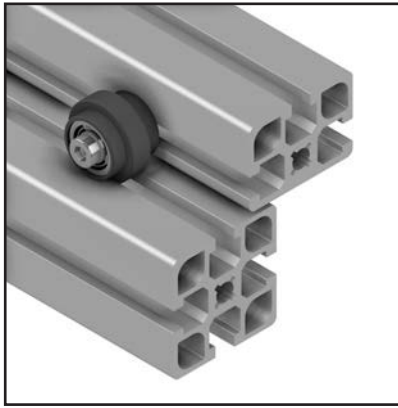
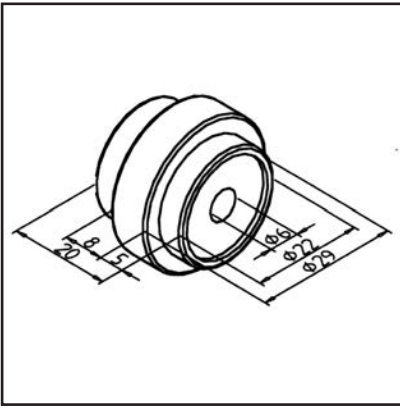

TECHN. DATA / ITEMS SUPPLIED

- ABS, Injection Mould, grey
- With 2 ball-bearings 626 ZZ
- Fmax. 200 N
- Weight = 0.030 kg/piece

APPLICATIONS

- Guide for sliding doors, lifting doors and drawers

ASSEMBLY

- With cylinder head screw M6 x 35 **part no.:** 21.1245/0 and sliding nut M6 on profile grooves or directly on surface element

ROLLER WHEEL S

Part no. 21.1781/0

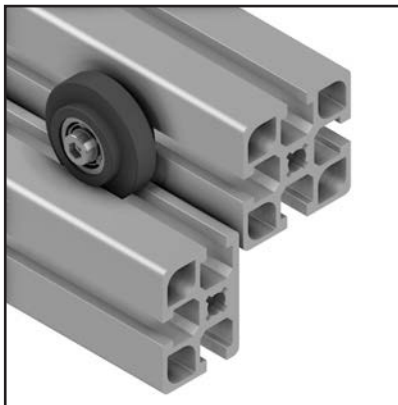
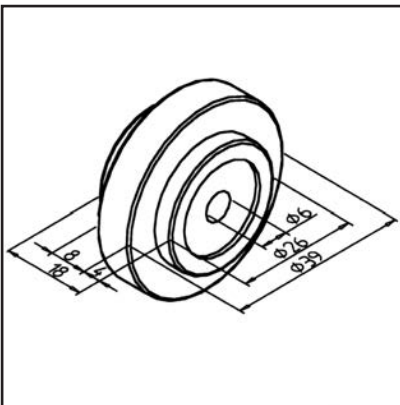

TECHN. DATA / ITEMS SUPPLIED

- PA, Injection Mould, grey
- With 2 ball-bearings 626 ZZ
- Fmax. 200 N
- Weight = 0.040 kg/piece

APPLICATIONS

- Guide for sliding doors, lifting doors and drawers

ASSEMBLY

- With cylinder head screw M6 x 35 **part no.:** 21.1245/0 and sliding nut M6 on profile grooves or directly on surface element

TRACK PROFILE

Part no.

20.1038/0

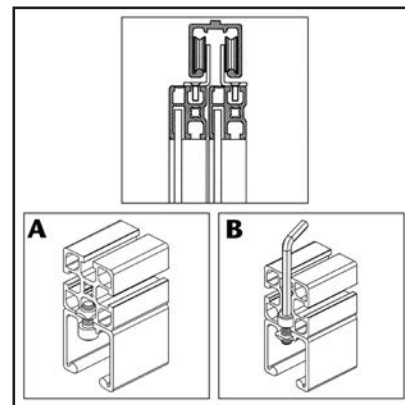
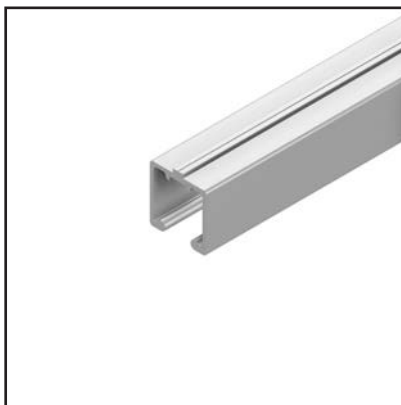
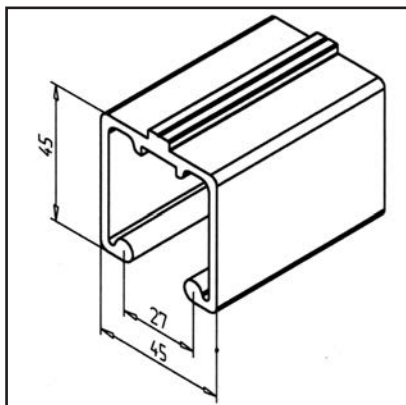

TECHN. DATA / ITEMS SUPPLIED

- Aluminium, extruded, anodized E6/EV1
- $I_x = 15.347 \text{ cm}^4$
- $I_y = 15.597 \text{ cm}^4$
- $w_x = 5.912 \text{ cm}^3$
- $w_y = 6.932 \text{ cm}^3$
- Weight = 1.470 kg/m
- Bar length = 6 m
- Packing unit = 48 m

APPLICATIONS

- Multi-leaf sliding doors
- Single-leaf sliding doors

ASSEMBLY

- Drill $\varnothing 8,5$ mm holes in centering groove; bore pitch: 250 - 400 mm depending on the load
- A) Position M8 F square nuts in the supporting profile and fasten the sliding door profile with M8 x 25 hex socket cap screw
- B) Drill through or step holes into the carrier profile and insert square nut into the profile of the runner. Nuts are torsion-proof

ROLLER ELEMENT FOR SLIDING DOOR

Part no.

21.2000/0

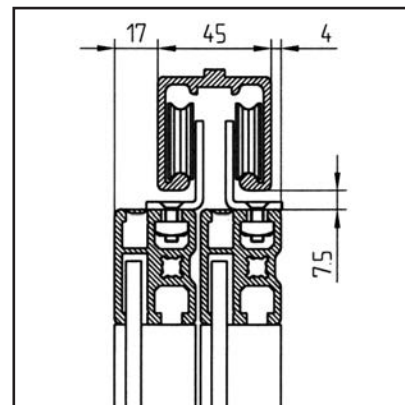
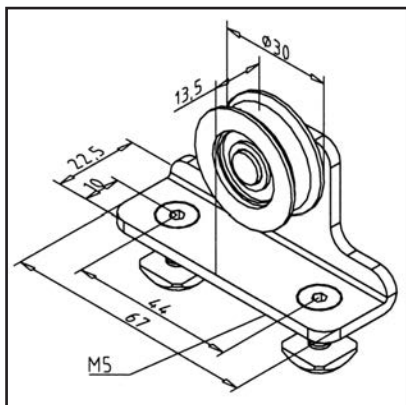

TECHN. DATA / ITEMS SUPPLIED

- Plastic roller with ball-bearing
- Zinc plated steel support
- With fastening material steel, zinc plated
- Weight = 0.080 kg/piece

APPLICATIONS

- Easy-running, multi-wing sliding doors in guard units, exhibition stands, testing units, etc.

ASSEMBLY

- Attach the rollers to the profile groove using the mounting kit
- Mount the doors into the track profile, slightly swing out the doors at the bottom
- Sliding door at bottom with retaining pins, sliding bar 8N **part no. 22.1085/0** oder U-Führung Schiebetür **part no. 21.2002/1** secure against swinging away

INTERLOCK SLIDING DOOR K

Part no.

21.2019/0

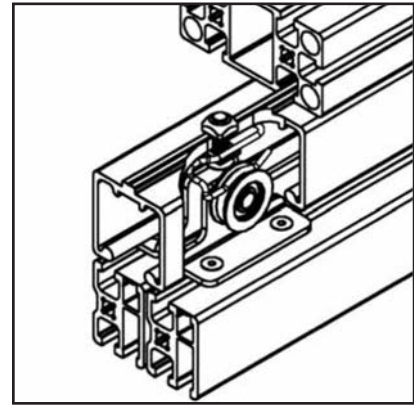
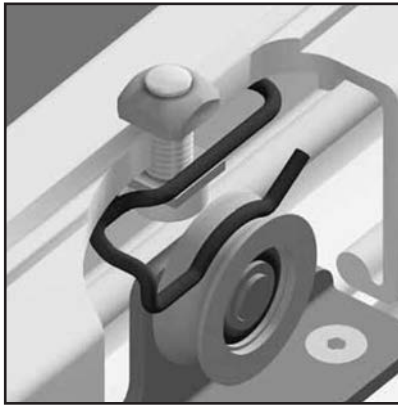
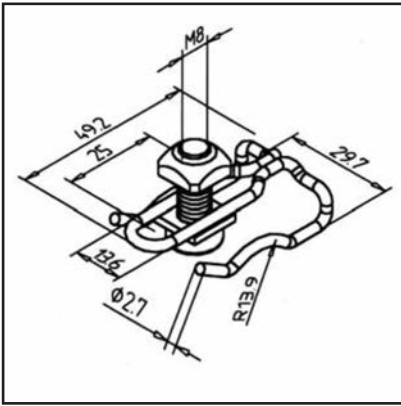

TECHN. DATA / ITEMS SUPPLIED

- Stainless steel
- Spring steel wire
- With fastening material steel, zinc plated
- Weight = 0.026 kg/piece

APPLICATIONS

- Interlock sliding doors in their end positions (open / closed)

ASSEMBLY

- Mark the end position of the roll
- Bore drill $\varnothing 8,5$ m in sliding door profile
- Screw into rail with carrier profile using mounting kit included

SAFETY CATCH FOR SLIDING DOOR

Part no.

21.2003/0

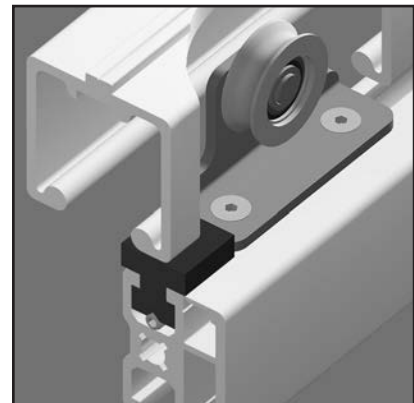
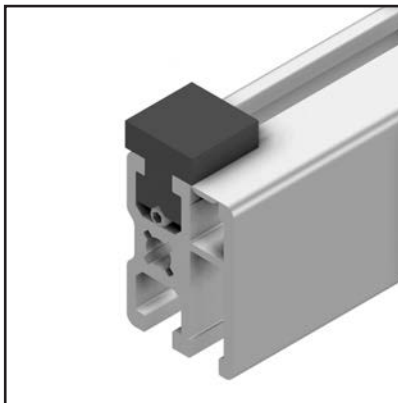
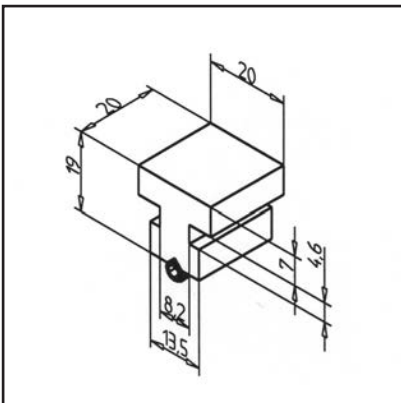

TECHN. DATA / ITEMS SUPPLIED

- PE-UHMW, black
- With fastening material steel, zinc plated
- Weight = 0.009 kg/piece

APPLICATIONS

- Securing of sliding doors against lift off
- Reduction of pendulum motion

ASSEMBLY

- Insert the safety catch on the front side into the upper sliding door profile
- Fasten to the groove base through face-side screw using the threaded pin provided
- Install end cap

U-BAR FOR SLIDING DOOR

Part no.

21.2002/0

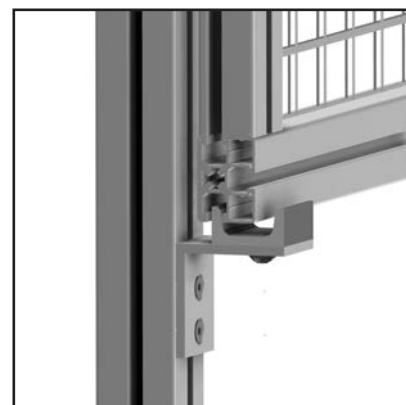
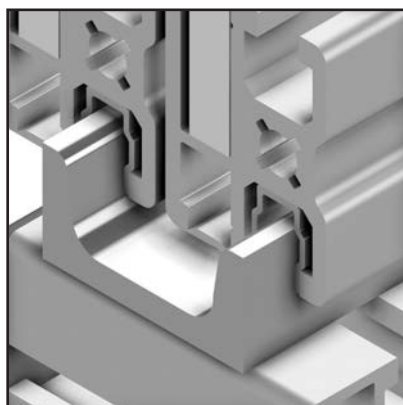
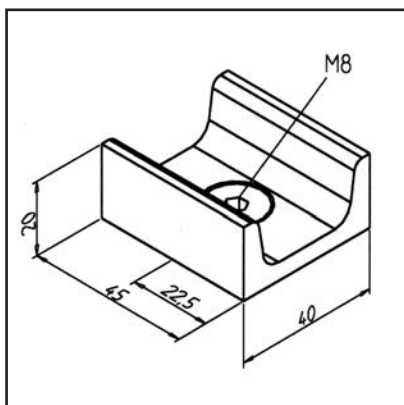
**TECHN. DATA / ITEMS SUPPLIED**

- Steel, galvanized
- With fastening material steel, zinc plated
- Weight = 0.150 kg/piece

APPLICATIONS

- Securing of sliding doors against lateral swinging

ASSEMBLY

- Hang up the doors
- Mount the U-rail on the profile piece and slide it into position
- Provide doors below with edging and cover profiles, if necessary

ROLLER SHUTTER WITH DRIVE

Part no.

29.0402/0

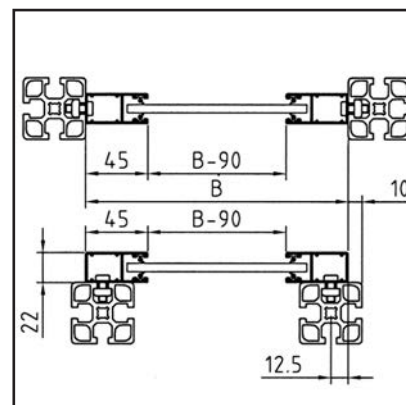
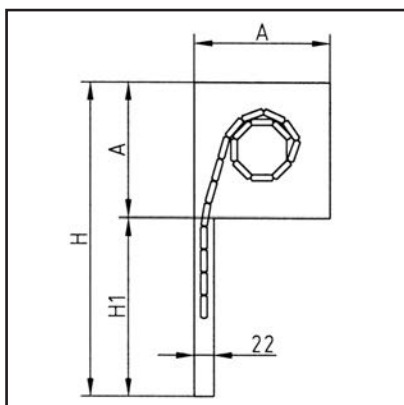
**TECHN. DATA / ITEMS SUPPLIED**

- Aluminium, powder coated, silver
- 2 sides Guide rails; roller shutter box with drive
- Electr. drive 230 V
- without switch
- Max. Width: 2,70 m
- Cable length 2 m
- **Please indicate width B and dimension H**

APPLICATIONS

- Cupboard for instruments
- Tool cabinets
- Output switch
- Computer racks
- Machine guards

ASSEMBLY

- Connect the roller shutter box to the guide rails
- Fasten the guide rails and roller shutter box to the profile frame
- Roller Shutter Case A = 152, H bis 1,70 m, **part no. 29.0402/0**
- Roller Shutter Case A = 167,5, H bis 2,20 m, **part no. 29.0403/0**
- Roller Shutter Case A = 181, H bis 2,70 m, **part no. 29.0404/0**
- Stroke H1: H-A

SECURITY SWITCH AZ 16 ZVRK

Part no. 21.1110/0

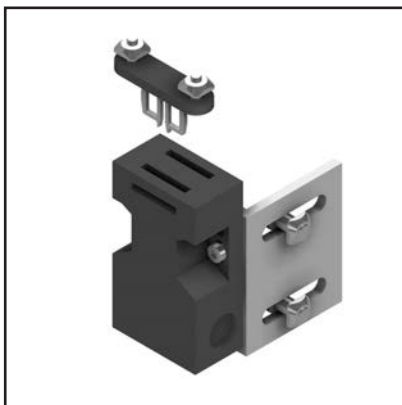
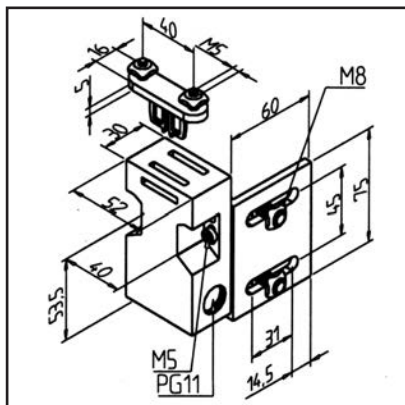

TECHN. DATA / ITEMS SUPPLIED

- Security switch, complete with switching pad, type B1, standard, IP 67
- 1 NC contact, 1 NO contact
- Fastening angle, aluminium, natural anodized
- Fastening kit
- Latching force 30 N
- Weight = 0.343 kg/piece

APPLICATIONS

- Protection for doors, lifting devices, panels in all types of protective installations
- Suitable for all 45er profiles

ASSEMBLY

- Fasten with fastening material to profile groove
- Easy adjustment in x-, y- and z-axis by means of long holes in the angle-bracket
- For small radii, operating bars B2 **part no. 21.1110/2** or B3 **part no. 21.1110/3** use

MOUNTING ANGLE BRACKET FOR SAFETY SWITCH

Part no. 21.1359/0

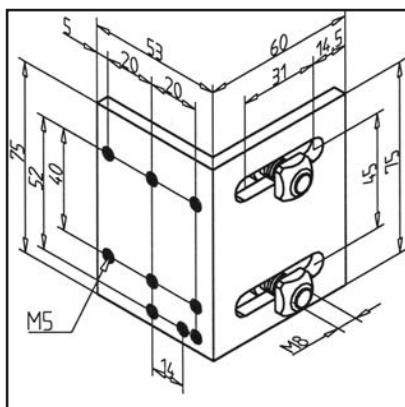

TECHN. DATA / ITEMS SUPPLIED

- Aluminium, anodized E6/EV1
- With fastening material steel, zinc plated
- Use on vertical struts **part no. 21.1359/7** (square nut with position-fixing)
- Weight = 0.128 kg/piece

APPLICATIONS

- For safety switch according to DIN EN 50041
- Adjust the switch in two directions

ASSEMBLY

- Fasten with fixing material to profile groove

ACTUATING BOW FOR SECURITY SWITCH B3

Part no.

21.1110/3

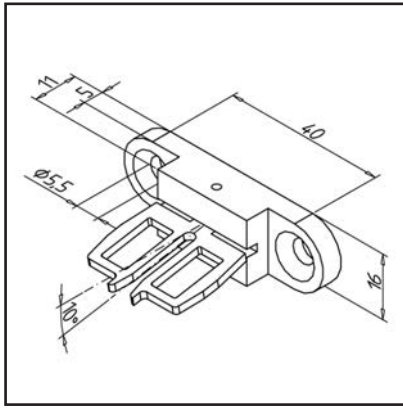
**TECHN. DATA / ITEMS SUPPLIED**

- Separator guide, typ B3, for particularly small operating radius over the narrow side of the bracket
- Weight = 0.030 kg/piece

**APPLICATIONS**

- Operating handle for small operating radii in conjunction with safety switch **part no. 21.1110/0**, replaces the standard strap

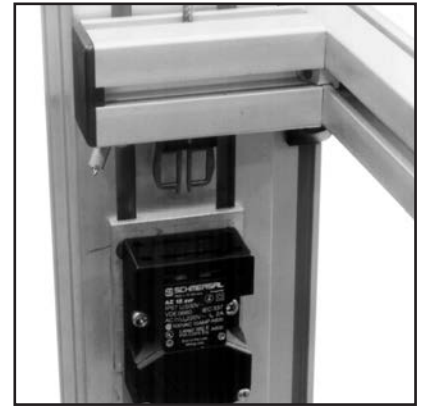
**ASSEMBLY**

- With fastening kit from items supplied secure the safety switch to the profile groove
- Directly on panel element with countersunk screws M5 according to material thickness

ACTUATING BOW FOR SECURITY SWITCH B2

Part no.

21.1110/2

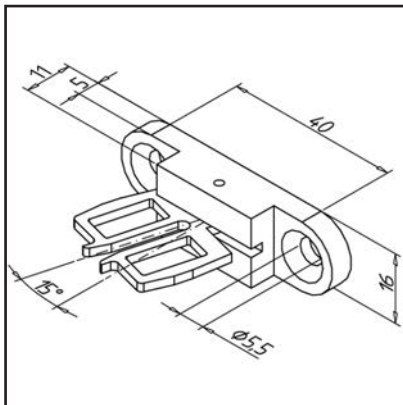
**TECHN. DATA / ITEMS SUPPLIED**

- Separator guide, B2, for particularly small operating radius over the wide side of the bracket
- Weight = 0.030 kg/piece

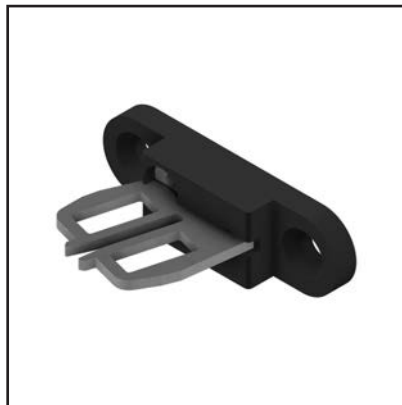
**APPLICATIONS**

- Operating handle for small operating radii in conjunction with safety switch **part no. 21.1110/0**, replaces the standard strap

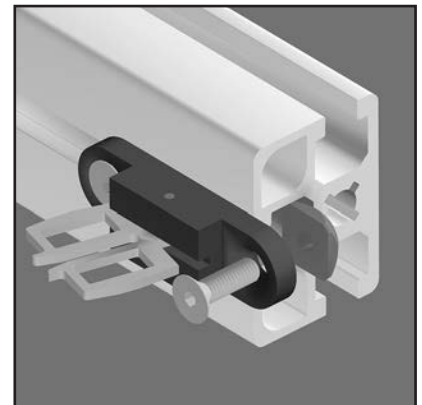
**ASSEMBLY**

- With fastening kit from items supplied secure the safety switch to the profile groove
- Directly on panel element with countersunk screws M5 according to material thickness

SECURITY SWITCH WITH LOCK

Part no.

21.1766/0

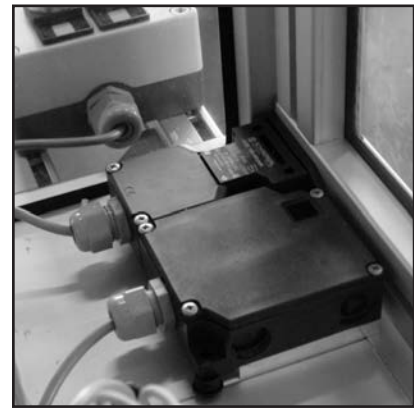
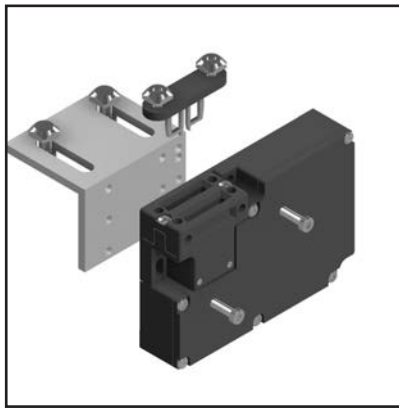
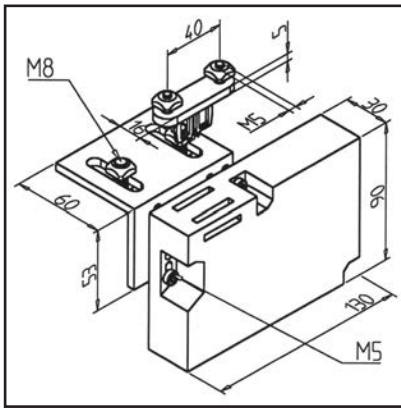

TECHN. DATA / ITEMS SUPPLIED

- Switch, type AZM 161SK-12/12RK-024
- Thermoplastic housing, black, self-extinguishing
- Protective system IP67, nominal operating current 10 A (230 V), driving voltage 24 V AC/DC, power consumption 10 W
- Fastening kit
- Optionally also with control voltage 110 V AC or 230 V AC available
- Weight = 0.480 kg/piece

APPLICATIONS

- For protective equipment with high safety requirements

ASSEMBLY

- Fasten with fixing material to profile groove
- For small radii, use actuating yoke B6 **part no. 21.1766/2**.

CABLE DUCT 27 AL

Part no.

20.1051/0

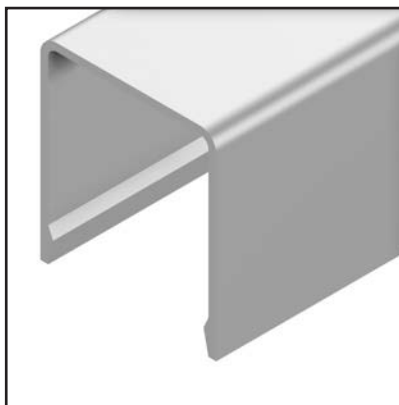
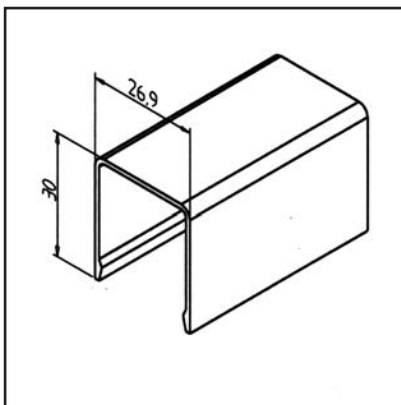

TECHN. DATA / ITEMS SUPPLIED

- Aluminium, extruded, anodized E6/EV1
- Weight = 0.193 kg/m
- Bar length = 6 m

APPLICATIONS

- Cover for cables and pneumatic hoses

ASSEMBLY

- On clamp **part no. 22.1204/0** or **part-no. 22.1212/0** clipping on
- Earthing brackets for optional grounding **part no. E9.0141/0** can be used

END CAP CABLE DUCT 27 AL

Part no.

22.1119/1

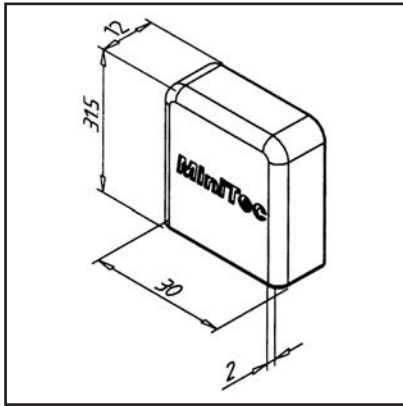
**TECHN. DATA / ITEMS SUPPLIED**

- ABS, Injection Mould, grey
- Weight = 0.004 kg/piece

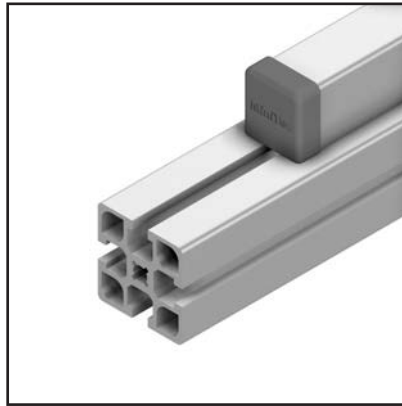
**APPLICATIONS**

- End cap for conduit AL
- Manufacture external angles with cable duct AL

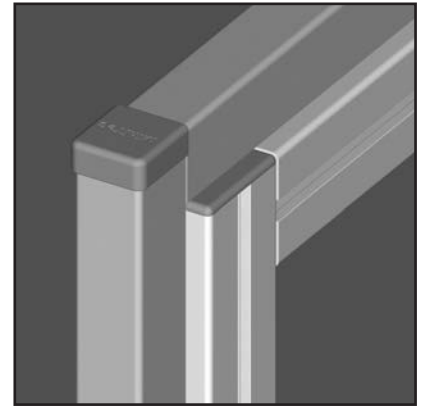
**ASSEMBLY**

- Simply push onto the end of the cable duct

EDGE PROTECTION FOR CABLE DUCT 27 AL

Part no.

22.1120/1

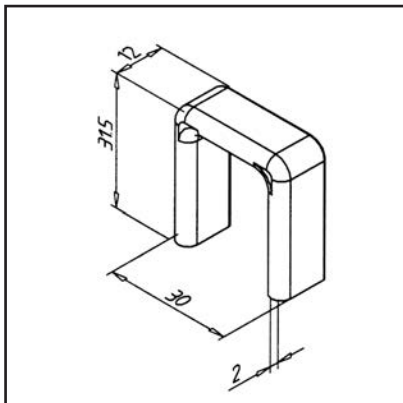
**TECHN. DATA / ITEMS SUPPLIED**

- ABS, Injection Mould, grey
- Weight = 0.003 kg/piece

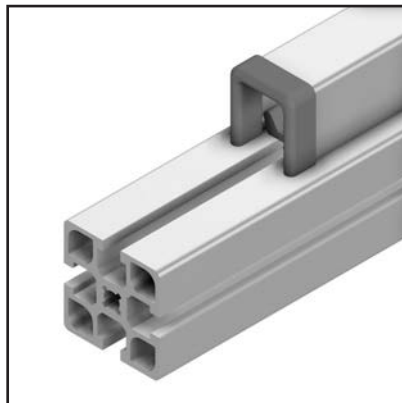
**APPLICATIONS**

- Edge protection for conduit AL

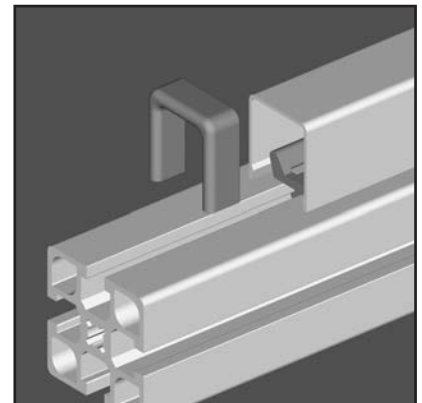
**ASSEMBLY**

- Simply push onto the end of the cable duct

INNER ANGLE CABLE DUCT 27 AL

Part no. 22.1121/1

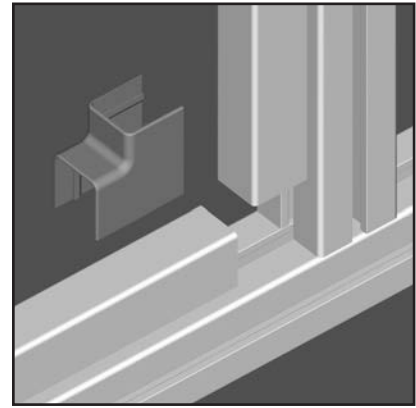
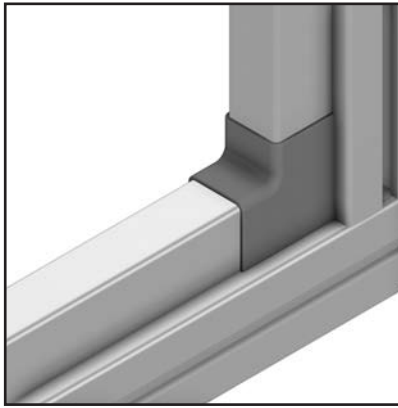
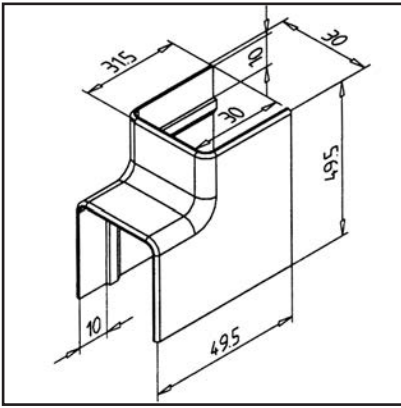

TECHN. DATA / ITEMS SUPPLIED

- ABS, Injection Mould, grey
- Weight = 0.009 kg/piece

APPLICATIONS

- Connect the cable duct AL to the inner angle

ASSEMBLY

- Clip the first side of cable duct on clamps.
- Insert the angle
- Click on the second side of the cable duct and slide along as far as the stop

CABLE DUCT 45 AL

Part no. 20.1071/0

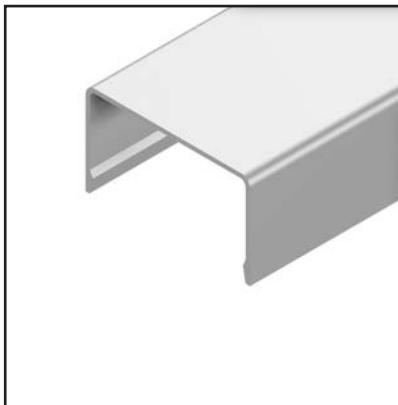
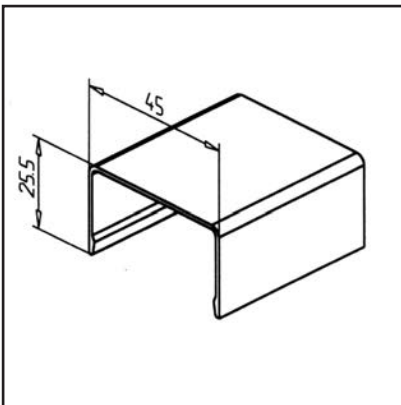

TECHN. DATA / ITEMS SUPPLIED

- Aluminium, anodized E6/EV1
- Weight = 0.301 kg/m
- Bar length = 6 m

APPLICATIONS

- Cover for cables and pneumatic hoses

ASSEMBLY

- On clamp 45 **part no. 22.1210/0** clipping on
- Earthing brackets for optional grounding **part no. E9.0141/0** can be used

CAP CABLE DUCT 45 AL

Part no. 22.1116/1

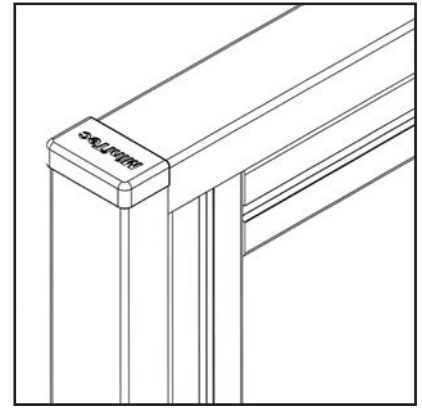
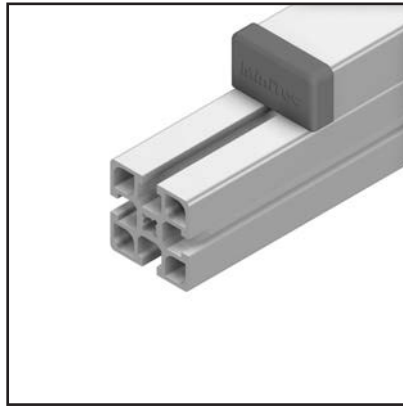
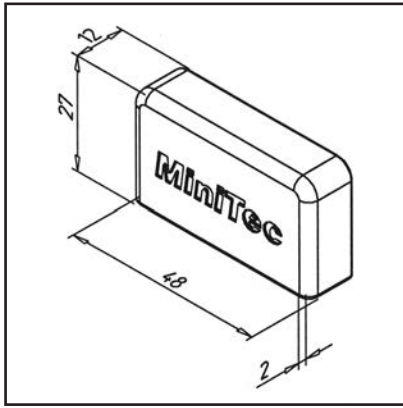

TECHN. DATA / ITEMS SUPPLIED

- ABS, Injection Mould, grey
- Weight = 0.006 kg/piece

APPLICATIONS

- Finish the cable duct 45
- Production of external angle with cable canal 45 AL

ASSEMBLY

- Simply push onto the end of the cable duct

PROTECTION CAP CABLE DUCT 45 AL

Part no. 22.1117/1

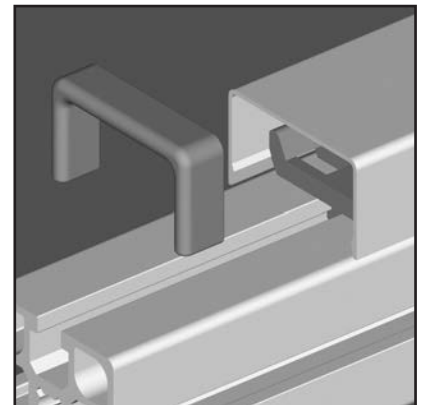
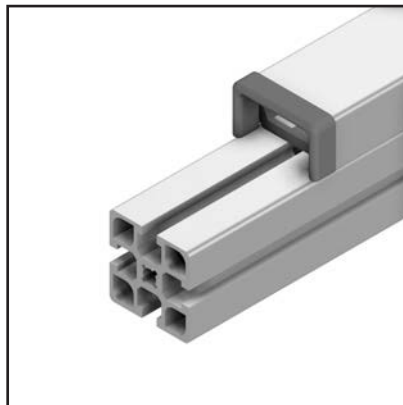
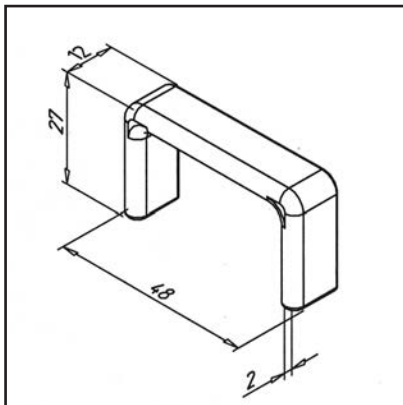

TECHN. DATA / ITEMS SUPPLIED

- ABS, Injection Mould, grey
- Weight = 0.005 kg/piece

APPLICATIONS

- Edge protection for Cabel Canal 45 AL

ASSEMBLY

- Simply push onto the end of the cable duct

INSIDE ANGLE CABLE DUCT 45 AL

Part no.

22.1118/1

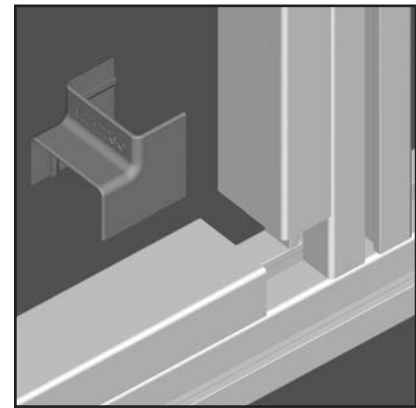
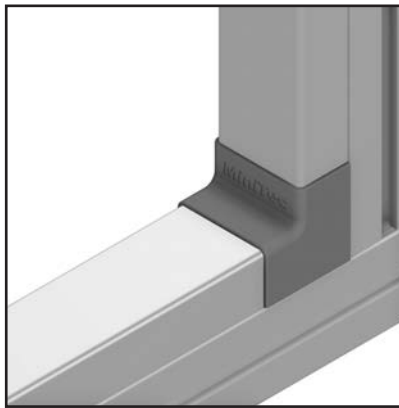
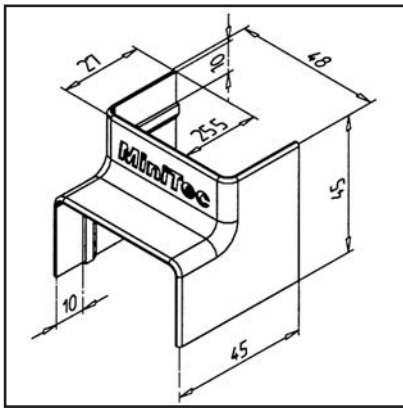

TECHN. DATA / ITEMS SUPPLIED

- ABS, Injection Mould, grey
- Weight = 0.010 kg/piece

APPLICATIONS

- Connecting cable canal 45 AL to internal angles

ASSEMBLY

- Clip the first side of cable duct on clamps.
- Insert the angle
- Click on the second side of the cable duct and slide along as far as the stop

ANGLE 90° FOR CABLE DUCT 45 AL

Part no.

22.1156/0

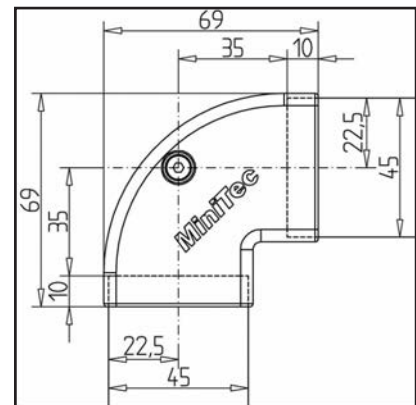
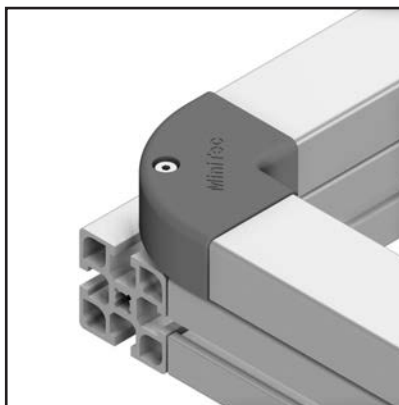
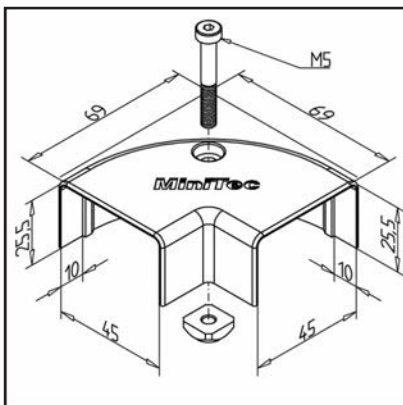

TECHN. DATA / ITEMS SUPPLIED

- ABS, Injection Mould, grey
- Fastening kit
- Weight = 0.026 kg/piece

APPLICATIONS

- Connection of cable canal 45 AL

ASSEMBLY

- Push on both channel ends 45, tighten the screw

ADAPTER CAP CONNECTOR STRIP FOR CABLE DUCT 45 AL

Part no.

22.1154/1

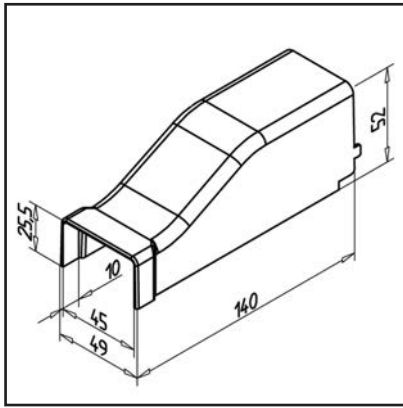

TECHN. DATA / ITEMS SUPPLIED

- ABS, Injection Mould, grey
- Weight = 0.034 kg/piece

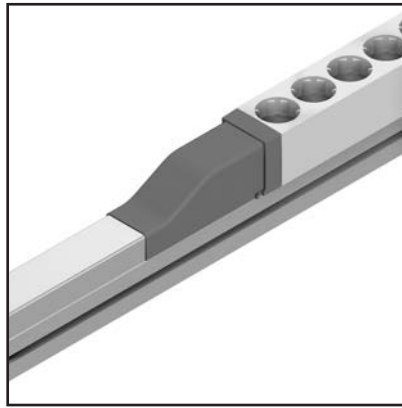

APPLICATIONS

- Cover of cable canal 45 AL

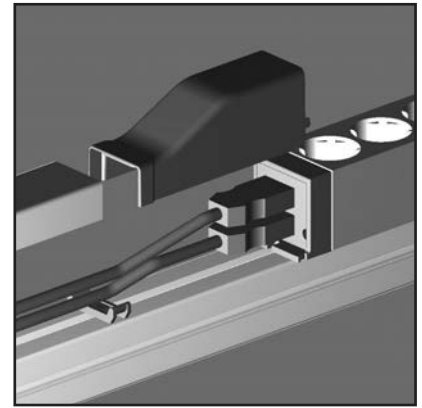

ASSEMBLY

- Clip onto cable conduit 45

CABLE DUCT 90 AL

Part no.

20.1056/0

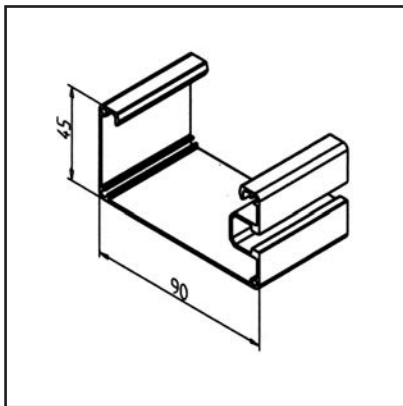

TECHN. DATA / ITEMS SUPPLIED

- Aluminium, anodized E6/EV1
- Weight = 0.971 kg/m
- Bar length = 6 m

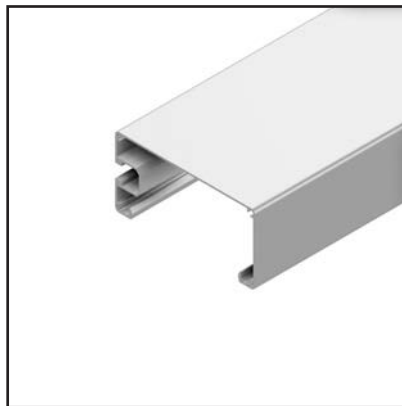

APPLICATIONS

- Cover for cables and pneumatic hoses
- Suitable for MiniTec profiles, grid dimension: 90
- Can also be swung open, when used with hinges
- End ledges with integrated energy supply



ASSEMBLY

- On clamp **part no. 22.1204/0** or **part-no. 22.1212/0** clipping on
- Cap **part no. 22.1045/0**
- Earthing brackets for optional grounding **part no. E9.0141/0** can be used

END CAP FOR CABLE DUCT 90 AL

Part no.

22.1045/0

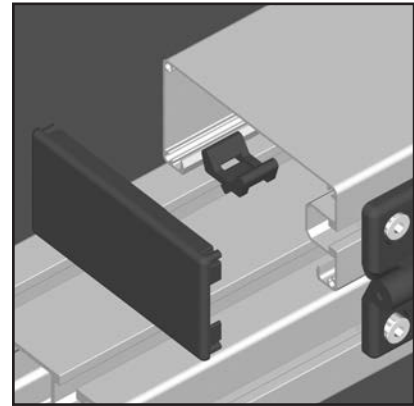
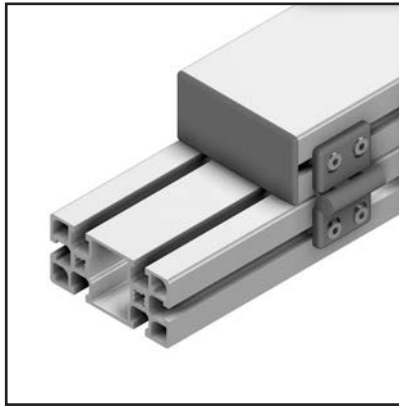
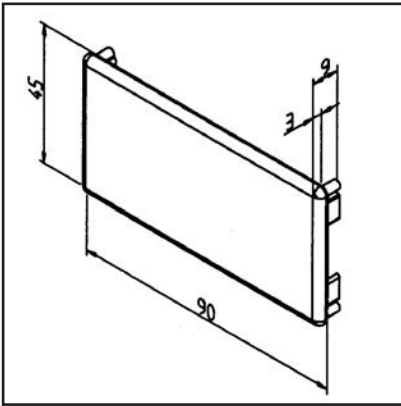

TECHN. DATA / ITEMS SUPPLIED

- ABS, Injection Mould, grey
- Weight = 0.011 kg/piece

APPLICATIONS

- Termination of cable canal 90 AL
- Constructions of corners on outside face

ASSEMBLY

- Simply push onto the end of the cable duct

CABLE CLIP 27-30

Part no.

22.1212/0

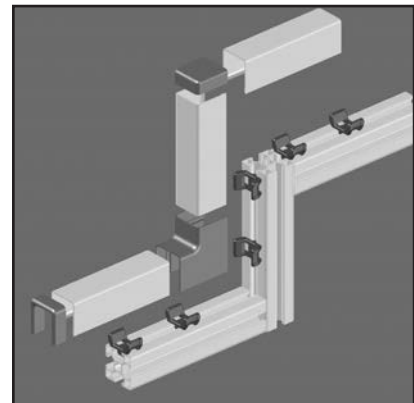
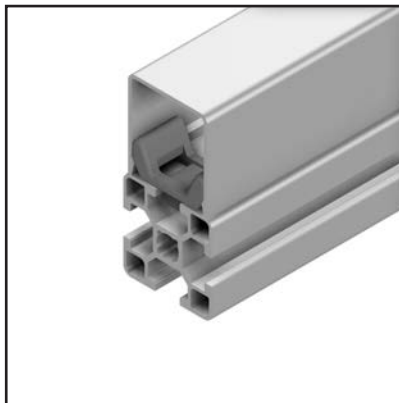
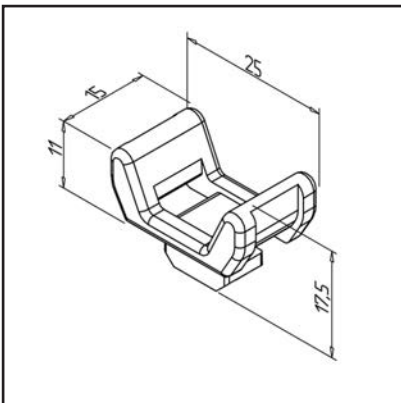

TECHN. DATA / ITEMS SUPPLIED

- PA, Injection Mould, grey
- Weight = 0.002 kg/piece

APPLICATIONS

- Simple and rational fastening of cables and pneumatic hoses
- Fixing of cable canal 27 AL
- For use of all profile types of profile series 30

ASSEMBLY

- Insert in profile groove and fix by 90° rotation
- Insert cable tie band through the cable clip and around the cable. Bind together, cut off any excessive length

CABLE CLIP 27-45

Part no.

22.1204/0

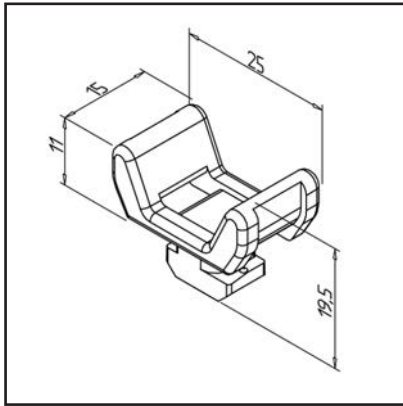
**TECHN. DATA / ITEMS SUPPLIED**

- PA, Injection Mould, grey
- Weight = 0.003 kg/piece

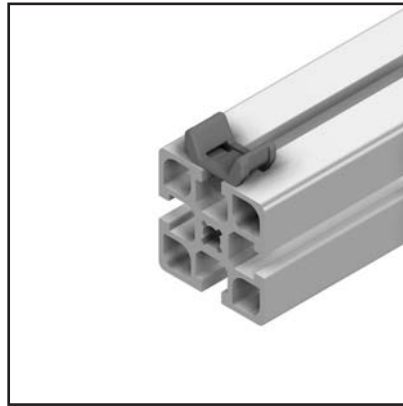
**APPLICATIONS**

- Simple and rational fastening of cables and pneumatic hoses
- Fixing of cable canal 27 AL and cable canal 90 AL
- Use with all profiles of the 45 profile series

**ASSEMBLY**

- Insert in profile groove and fix by 90° rotation
- Insert cable tie band through the cable clip and around the cable. Bind together, cut off any excessive length

CLAMP 27-45 C

Part no.

22.1216/0

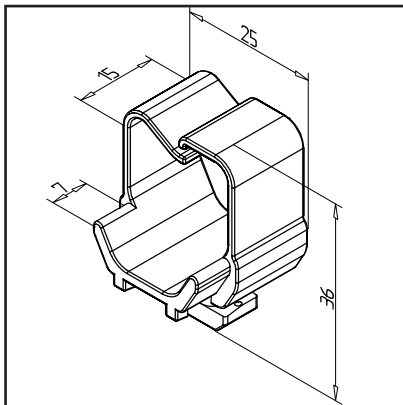
**TECHN. DATA / ITEMS SUPPLIED**

- PP, Injection Mould, grey
- Weight = 0.004 kg/piece

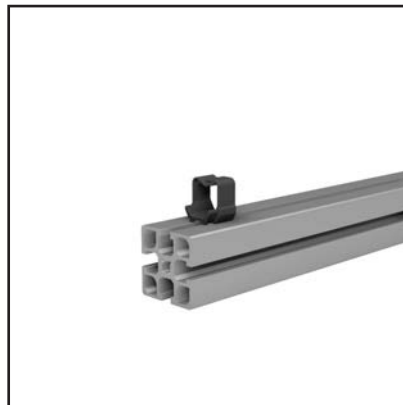
**APPLICATIONS**

- Simple and rational fastening of cables and pneumatic hoses
- Fixing of cable canal 27 AL and cable canal 90 AL
- Use with all profiles of the 45 profile series
- Preferably to be used for laying cables and hoses overhead or for frequent changes to the installation.

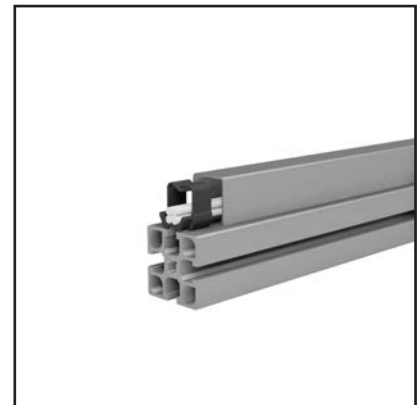
**ASSEMBLY**

- Insert in profile groove and fix by 90° rotation
- Simply clip cables and hoses up to 8 mm diameter into the clamp. Removal is also possible.
- If necessary, fasten cables with cable ties. Thread the cable ties into the end of the clamp (7mm) and tighten.

CABLE CLIP 45

Part no.

22.1210/0

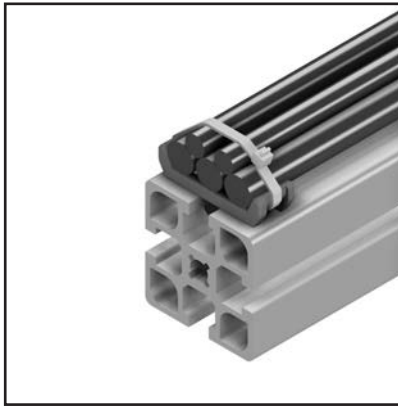
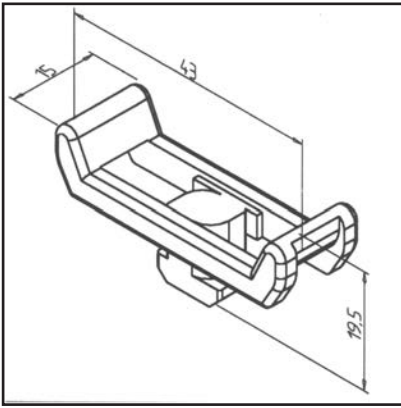

TECHN. DATA / ITEMS SUPPLIED

- PA, Injection Mould, grey
- Weight = 0.004 kg/piece

APPLICATIONS

- Simple and rational fastening of cables and pneumatic hoses
- Suitable for conduit 45 AL

ASSEMBLY

- Insert in profile groove and fix by 90° rotation
- Insert cable tie band through the cable clip and around the cable. Bind together, cut off any excessive length
- Cover of timing belt, chains etc.

CABLE CLAMP 45

Part no.

22.1270/0

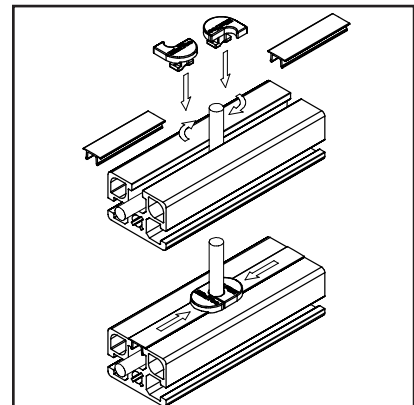
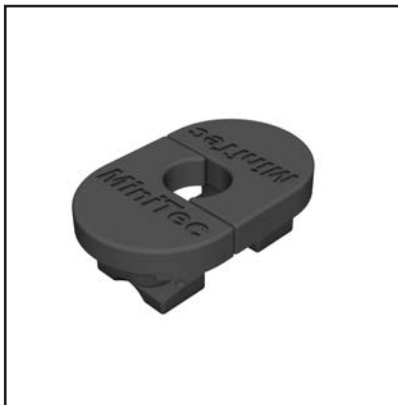
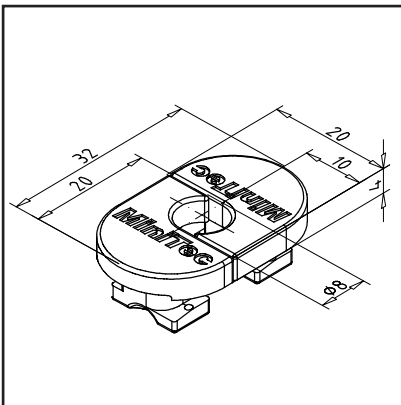

TECHN. DATA / ITEMS SUPPLIED

- ABS, Injection Mould, grey
- The cable clamp (2-part) consists of 2 identical components
- Weight = 0.028 kg/pair

APPLICATIONS

- For fixing cables and hoses laid in the profile groove
- For cables up to 8 mm diameter
- Please note the bending radius of the cables.
- Use with all profiles of the 45 profile series

ASSEMBLY

- Swing both parts to the left and right of the cable into the profile groove, then push them together.
- When using cover profiles to close the grooves, this can be pushed under the cable clamp approx. 4 mm deep.

ENERGY CHAIN R

Part no.

33.0410/0

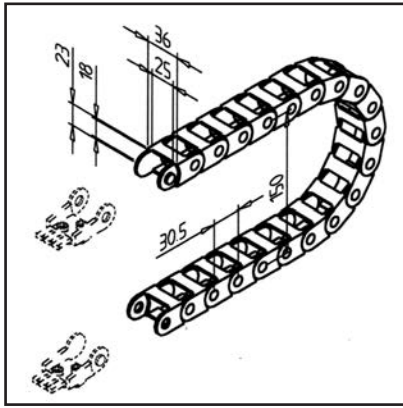

TECHN. DATA / ITEMS SUPPLIED

- Plastic, black
- Without fastening kit
- Weight = 0.341 kg/m



APPLICATIONS

- Energy chain to bind cables and hoses on slides and movable elements



ASSEMBLY

- Fixing the energy chain means of connection elements **part no. 33.0411/0**

MOUNTING BRACKETS FOR ENERGY CHAIN R

Part no.

33.0411/0

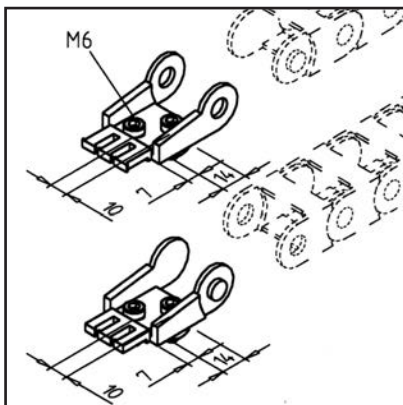

TECHN. DATA / ITEMS SUPPLIED

- Plastic, black
- With fastening material steel, zinc plated
- One element to the right and to the left
- Weight = 0.058 kg/piece

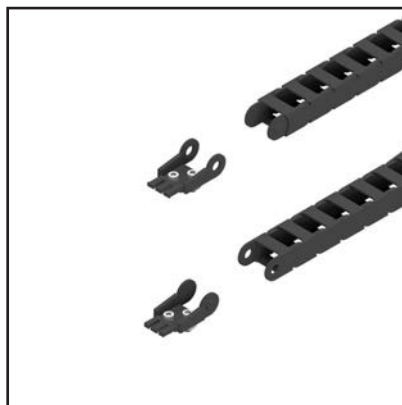

APPLICATIONS

- To attach the energy chain R **part no. 33.0410/0** to profile construction

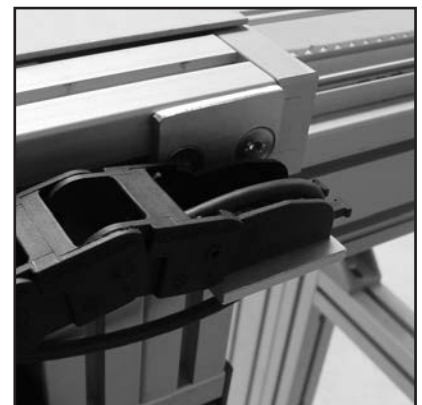

ASSEMBLY

- Fasten at a suitable place with supplied hardware
- Use cable tie band to fix cables and hoses

CABLE DUCT 32

Part no. 22.1082/0

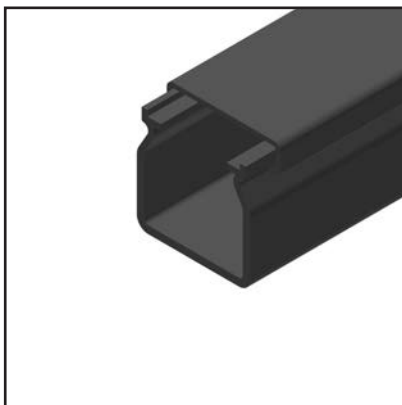
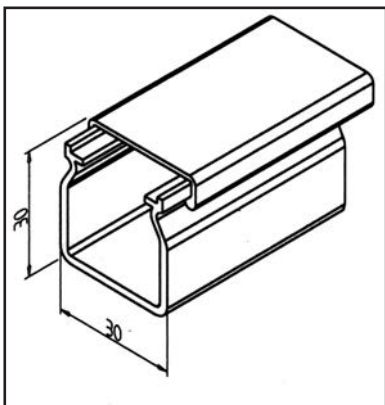

TECHN. DATA / ITEMS SUPPLIED

APPLICATIONS

ASSEMBLY

- PVC, grey
- Snap-cover
- Weight = 0.275 kg/m
- Bar length = 2 m

- Installation of cables and hoses of all kinds

- Fastening with screws M6 x 12 and rhombus-nut M6

CABLE DUCT 45

Part no. 22.1084/0

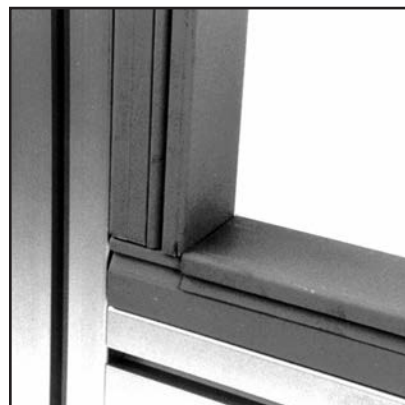
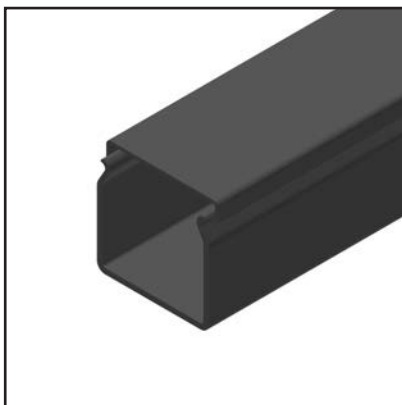
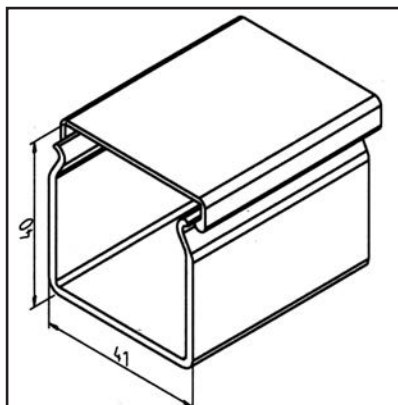

TECHN. DATA / ITEMS SUPPLIED

APPLICATIONS

ASSEMBLY

- PVC, grey
- Snap-cover
- Weight = 0.402 kg/m
- Bar length = 2 m

- Installation of cables and hoses of all kinds

- Fastening with screws M6 x 12 and rhombus-nut M6

PROXIMITY SWITCH HOLDER 12

Part no.

28.0120/0

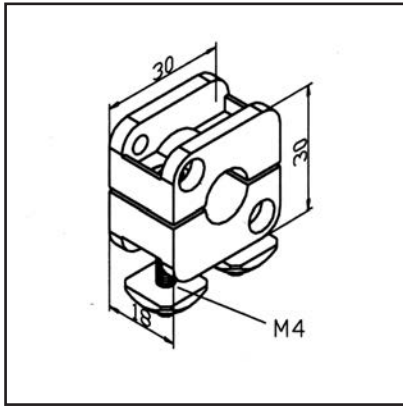
**TECHN. DATA / ITEMS SUPPLIED**

- Plastic, black
- With fastening material steel, zinc plated
- Ø 12
- Weight = 0.036 kg/piece

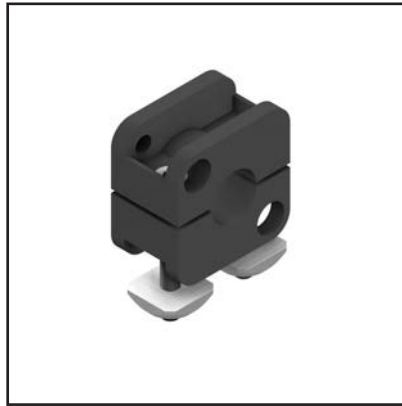
**APPLICATIONS**

- Fastening of proximity switches Ø 12 mm in profile constructions and linear guides

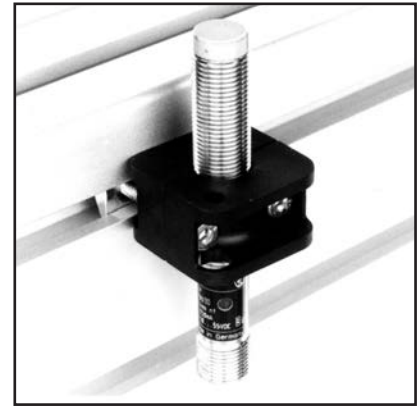
**ASSEMBLY**

- Fasten to profile groove with supplied hardware.

PROXIMITY SWITCH HOLDER 18

Part no.

28.0121/0

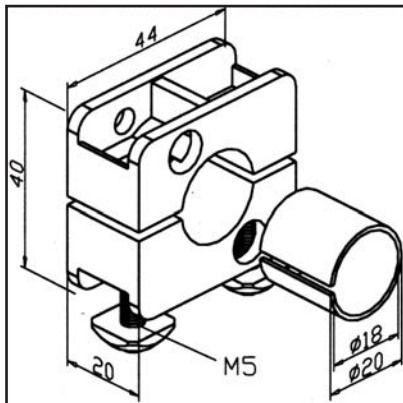
**TECHN. DATA / ITEMS SUPPLIED**

- Plastic
- With fastening material steel, zinc plated
- Ø 18 mm
- Ø 20 mm
- Weight = 0.046 kg/piece

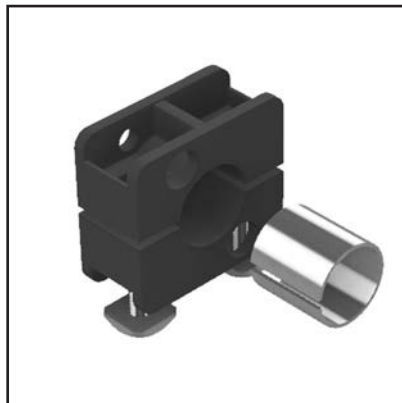
**APPLICATIONS**

- Fastening of proximity switches Ø 18 mm and Ø 20 mm in profile constructions and linear guides

**ASSEMBLY**

- Fasten to profile groove with supplied hardware.

PROXIMITY SWITCH HOLDER 30

Part no.

28.0122/0

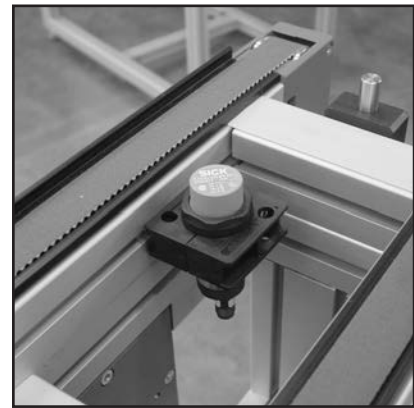
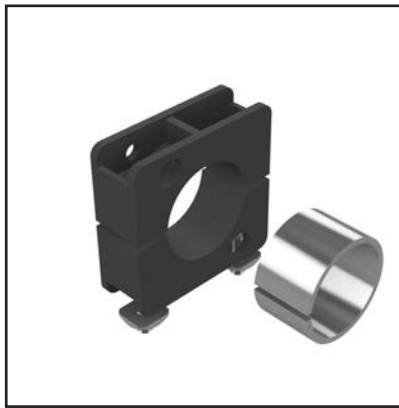
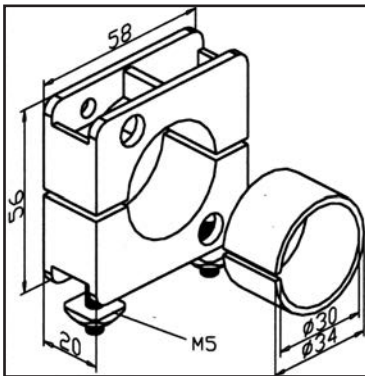

TECHN. DATA / ITEMS SUPPLIED

- Plastic, black
- With fastening material steel, zinc plated
- Ø 30 mm
- Ø 34 mm
- Weight = 0.068 kg/piece

APPLICATIONS

- Fixation of proximity switches Ø 30 and Ø 34 in profile constructions and linear axes

ASSEMBLY

- Fasten to profile groove with supplied hardware.

SENSOR HOLDERS

ALL SIDE SUPPORTS CAN BE COMBINED WITH ALL BEAMS

Carriers

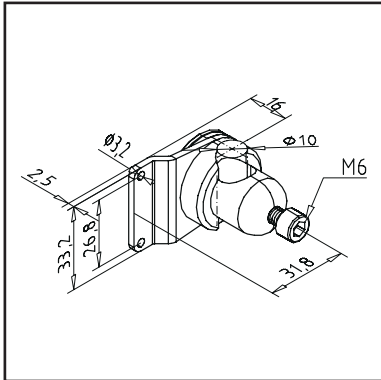

Part no. E1.0055/0

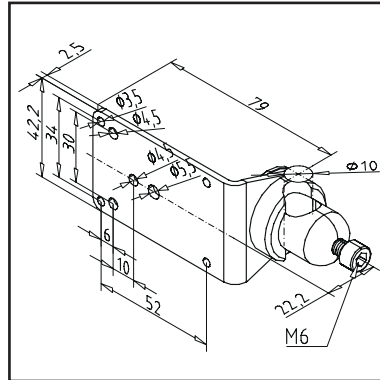

Part no. E1.0070/0

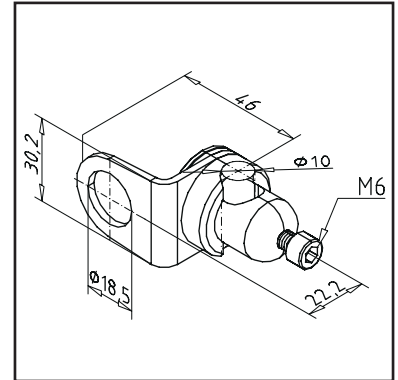

Part no. E1.0068/0

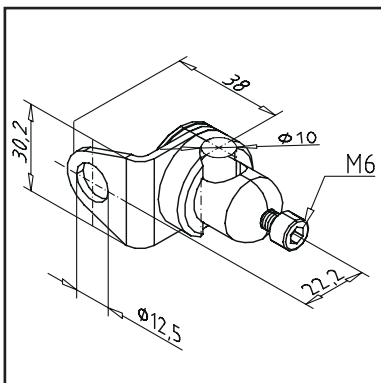

Part no. E1.0069/0

Lateral holders

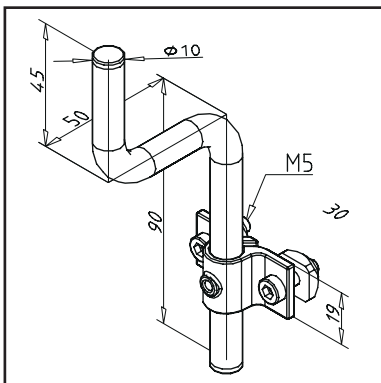

Part no. 29.5046/2

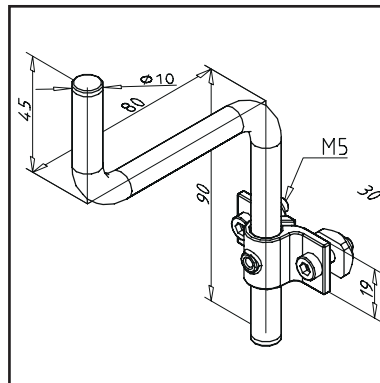

Part no. 29.5047/2

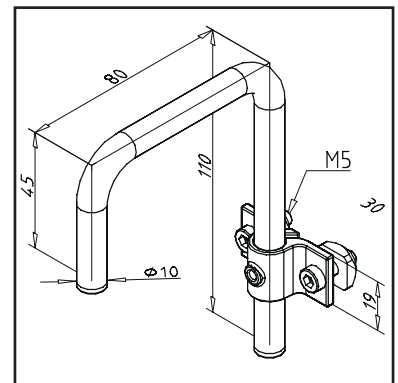

Part no. 29.5048/2

DRIVE AND CONTROL TECHNOLOGY

ELECTRICAL DESIGN, SWITCH CABINET PRODUCTION, SOFTWARE DEVELOPMENT AND VISUALIZATION

Comprehensive solutions from a single source

From problem analysis to commissioning: we not only offer proven components for plant construction and automation technology, but also project and implement individual overall concepts for material flow and assembly technology with our experienced team. In this way, resources are used in a targeted and effective manner. The basis for this is our flexible modular system consisting of profiles, linear technology and elements for ergonomic workplace design. These are supplemented by pneumatic and control technology components as well as conveyor systems, workpiece carrier transport systems and drives. From these parts, experienced specialists create modules which then grow together to form complete automation solutions for very individual tasks. Our goal is to develop the optimum solution for every task. Already in the planning phase, our customers benefit from our cross-industry experience. From the initial concept to commissioning, you will be expertly and seamlessly accompanied by our team.

Electrical constructions

The basis of the electrical design is the planning of the hardware. Thanks to our experience with tasks from a wide variety of industrial sectors and our many years of cooperation with all capable manufacturers, we are able to select the optimum configuration for the respective task. We create the hardware plans with the most modern CAD software E-Plan Electric P8. A meaningful documentation is thus generated for each development. As a rule, we create control concepts on a modular basis with decentralized intelligence. Different bus systems such as ProfiNet or I/O Link are used according to the requirements of our customers and the task at hand. Our specialists take over the design of the drives, taking into account the economic efficiency and the mechanics used. State-of-the-art servo technology with integrated safety functions is standard in our systems.

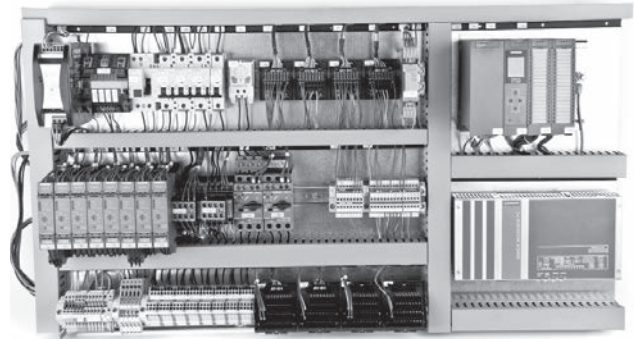

Switch cabinet production

Switch cabinets are assembled and wired in-house by our specialists according to the specifications of the electrical planning and approval by our customers. An intensive in-house functional test with the latest test equipment guarantees the quality and safe functioning of our systems.



DRIVE AND CONTROL TECHNOLOGY

Software development

The sequence programs of our systems are created for PLC or PC control. Programming is carried out by our specialists using Simatic Step 7 and the TIA Portal according to IEC standards. Manufacturer independent CoDe-Sys programming is also possible.

The integration of our complete solutions into the customer's existing ERP can also be realized on request.

**Visualization - safe operation and monitoring**

Clear mapping of the control processes is an indispensable prerequisite for safe operation of the system. With WinCC flexible we create user interfaces that not only visualize the process, but also visually signal error messages or display help texts that are easy for the operator to understand. Our mobile HMI panels make it much easier to operate and set up complex systems. With different user levels the visualization can be activated and adapted according to the respective logged in user.

....Your partner for the complete conception:

- Consultation
- Planning
- Mechanical and electrical engineering
- Software development and visualization
- Commissioning
- CE compliant design
- Documentation
- Service such as remote maintenance

DRIVE UNITS

PLUG-ON DRIVE UNIT SUITABLE FOR CONVEYOR BELT SERIES 45*

Technical Data

- Nominal voltage 230 / 400 V
- 50 Hz
- Protection IP 54
- Weight ca. 6kg

For attachment to a drum bearing 45, a torque arm WA 10 **part no. 295040/0** is required.

Optionally available with holding brake or thermocouple, also with different position of the terminal box and cable input (data sheets on request)

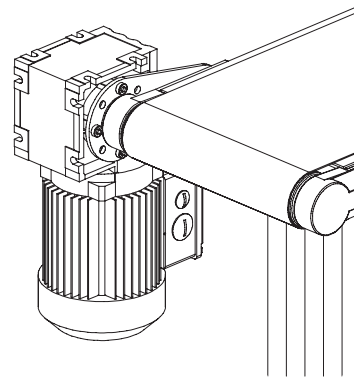

Type	Part no.	Power [W]	Output speed	Output torque	Conveyor belt 45 Conveyor speed	Center drive KR Belt speed
WA10 DT56 M4 - 17	33.0015/0	90	17 U/min	20 Nm	2,6 m/min	2,4 m/min
WA10 DT56 M4 - 22	33.0016/0	90	22 U/min	18 Nm	3,4 m/min	3,1 m/min
WA10 DT56 M4 - 33	33.0017/0	90	33 U/min	15 Nm	5,1 m/min	4,6 m/min
WA10 DT56 L4 - 53	33.0023/0	120	53 U/min	15 Nm	8,3 m/min	6,1 m/min
WA10 DT56 L4 - 67	33.0018/0	120	67 U/min	13 Nm	10,5 m/min	7,5 m/min
WA10 DT56 L4 - 79	33.0019/0	120	79 U/min	11 Nm	12,4 m/min	11,2 m/min
WA10 DT56 L4 - 127	33.0020/0	120	127 U/min	7,7 Nm	19,9 m/min	18,0 m/min
WA10 DT56 L4 - 159	33.0021/0	120	159 U/min	6,3 Nm	24,9 m/min	22,5 m/min

* from this motor series, other services and translations are available on request.

FLANGED GEAR MOTOR SUITABLE FOR MOTOR ATTACHMENT KIT 45* Ø20

Technical Data

- Nominal voltage 230 / 400 V
- 50 Hz
- Protection IP 54
- Weight ca. 7 - 9 kg

Optionally available with holding brake, thermocouple or external fan, also with different position of terminal box and cable input (data sheets on request)

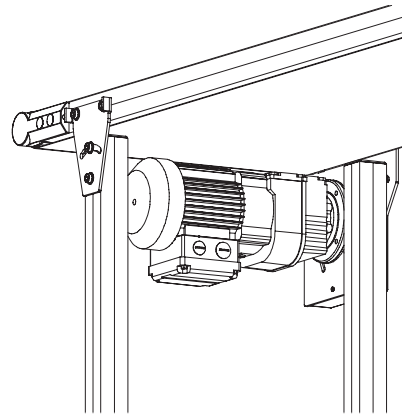

Type	Part no.	Power [W]	Output speed	Output torque	Kit engine attachment 45 Conveyor Speed
DGM-120-17 / F	33.0086/0	120	17 U/min	68 Nm	3,3 m/min
DGM-120-31 / F	33.0087/0	120	31 U/min	37 Nm	6,1 m/min
DGM-120-47 / F	33.0088/0	120	47 U/min	24 Nm	9,2 m/min
DGM-180-61 / F	33.0089/0	180	61 U/min	28 Nm	11,9 m/min
DGM-180-79 / F	33.0090/0	180	79 U/min	22 Nm	15,5 m/min
DGM-250-92 / F	33.0091/0	250	92 U/min	26 Nm	18,0 m/min
DGM-370-123 / F	33.0092/0	370	123 U/min	29 Nm	24,1 m/min
DGM-370-153 / F	33.0093/0	370	153 U/min	22 Nm	30,0 m/min

* From this motor series, other services and translations are available on request.

DRIVE UNITS

PLUG-ON DRIVE UNIT SUITABLE FOR CONVEYOR BELT SERIES 90*

Technical Data

- Nominal voltage 230 / 400 V 50 Hz
- Protection IP 54
- Weight ca. 7 - 13kg

For attachment to a drum bearing 90 a torque arm is required. Torque arm WA20 (part no. 295036/0) or torque arm WA30 (part no. 295037/0).

Optionally available with holding brake, thermocouple or external fan, also with different position of terminal box and cable input (data sheets on request)

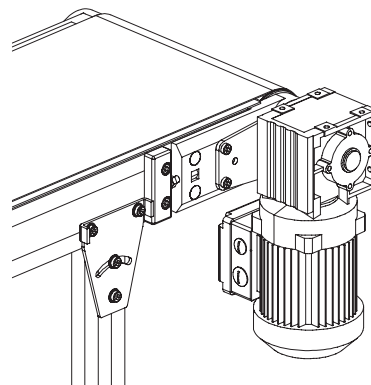

Type	Part no.	Power [W]	Output speed	Output torque	Conveyor belt 90 Conveyor speed	Torque arm
DSGM 180-15	33.0080/0	180	15 U/min	48 Nm	4,4 m/min	WA20
DSGM 250-27	33.0081/0	250	27 U/min	44 Nm	8,0 m/min	WA20
DSGM 370-35	33.0082/0	370	35 U/min	63 Nm	10,4 m/min	WA30
DSGM 370-50	33.0083/0	370	50 U/min	49 Nm	14,9 m/min	WA30
DSGM 370-71	33.0084/0	370	71 U/min	38 Nm	21,1 m/min	WA30
DSGM 550-115	33.0085/0	550	115 U/min	32 Nm	34,3 m/min	WA30

* From this motor series, other services and translations are available on request.

FLANGED GEAR MOTOR SUITABLE FOR MOTOR ATTACHMENT KIT 90*

Technical Data

- Nominal voltage 230 / 400 V
- 50 Hz
- Protection IP 54
- Weight ca. 7 - 13 kg

Optionally available with holding brake, thermocouple or external fan, also with different position of the terminal box and cable input (data sheets on request)

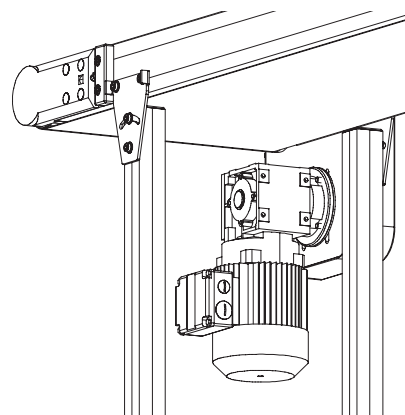

Type	Part no.	Power [W]	Output speed	Output torque	Kit engine attachment Conveyor speed	Center drive 3R Belt speed
DSGM 180 - 15 / F	33.0080/1	180	15 U/min	48 Nm	4,4 m/min	3,8 m/min
DSGM 250 - 27 / F	33.0081/1	250	27 U/min	44 Nm	8,0 m/min	6,8 m/min
DSGM 370 - 35 / F	33.0082/1	370	35 U/min	63 Nm	10,4 m/min	8,8 m/min
DSGM 370 - 50 / F	33.0083/1	370	50 U/min	49 Nm	14,9 m/min	12,6 m/min
DSGM 370 - 71 / F	33.0084/1	370	71 U/min	38 Nm	21,1 m/min	17,8 m/min
DSGM 550 - 115 / F	33.0085/1	550	115 U/min	35 Nm	34,3 m/min	28,9 m/min

* From this motor series, other services and translations are available on request.

FREQUENCY CONVERTER FU 370 PP

Technical Data

- Built-in on / off switch
- Mode 1Q (without brake - chopper)
- Mains overvoltage and undervoltage monitoring
- Engine load monitoring
- Short-circuit monitoring phase / phase, phase / earth
- Adjustable acceleration and deceleration ramp
- Adjustable voltage boost at low output frequency
- Power cord with earthing contact plug 230 V and motor cable, ELPUR, 5 m long with earthing contact plug, colour orange
- EMC filter class B
- IP 66/ NEMA-4X-casing
- Equipped as standard with an operator panel that allows operation and setup of the drives without the need for additional equipment
- Output power motor side max. Motor power 0.37 kW
- Output rated current max. 2.3 A
- Output voltage 3 x 20 - 250 V
- Overload 150% for 60 seconds
- Input voltage mains side rated voltage 230V
- Input current 6,7 A
- Power frequency 50 - 60 Hz
- Ambient temperature -10 ° C to + 40 ° C
- Heat loss at rated power 11 W
- Dimensions H / W / D: 232 x 161 x 179 mm



ART.-NR. 33.0126/0

MAGNETIC MEASURING SYSTEM

MAGNETIC MEASURING SYSTEM ML

Length or distance measurement is one of the standard tasks in mechanical engineering and construction. A modern and reasonably priced solution is the ML magnetic length measuring system with magnetic tape, magnetic sensor and measuring display. The advantages of this system are mainly in the direct measuring method, the wear-free, the simple and inexpensive installation and high possible accuracy.

At the heart of this measuring system is the magnetic tape, a flexible plastic tape filled with magnetic particles. This is glued to the profile surface and protected with a stainless steel strip, also glued. About this band is at a small distance, but non-contact, guided along a magnetic sensor and thus scanned the magnetic field. Movement direction and increments are then derived from these scanning signals and further processed in a controller or displayed by means of a measuring display.

LCD meter with battery operation incl. magnetic sensor (Part No. 33.0038/0)

- 6-digit LCD display, with 14mm digit height
- Surface-mount housing, aluminum powder-coated RAL 5010, dimensions W = 125mm, H = 65mm, depth = 85mm
- Power supply battery C (baby 1,5V)
- Battery compartment on the right side
- With attached magnetic sensor (cable length 0.5m)
- for mounting on stop slides via brackets
- Operating temperatur -5 to +45° C
- Travel speed max. 3m / sec, counting frequency up to 1MHz
- Actual value memory / offset value, selectable
- Absolute - incremental - conversion
- Measuring tolerance $\pm 0,1$ mm/m

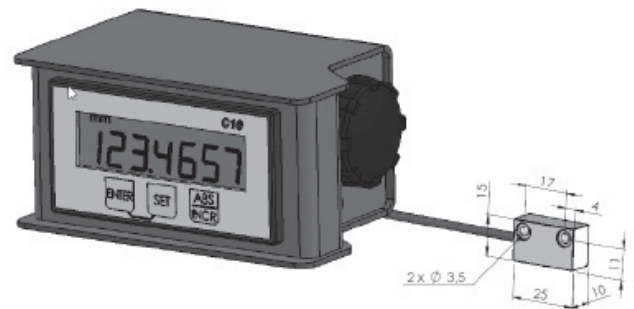

Measuring display for 230V connection Part no. 33.0036/0

- 6-digit LED display, with 14mm digit height
- Surface-mount housing, aluminum powder-coated RAL 5010, dimensions W = 115mm, H = 70mm, depth = 120mm
- Power supply 230V AC pluggable.
- Sensor connection via SuB-D 9-pin. pluggable, TTL 5VDC
- Operating temperatur -5 to +45° C
- Travel speed max. 3m / sec, counting frequency up to 1MHz
- Actual value memory / offset value, selectable
- Magnetic sensor Part no. 33.0037/0 please order separately, specifying the desired cable length



MAGNETIC MEASURING SYSTEM



Magnetic sensor with integrated evaluation unit Part no. 33.0037/0

- Non-contact measuring scanner with integrated digital evaluation electronics.
- Detecting the magnetic signals, with index pulse, resolution 10µm
- In conjunction with the above displayed measuring display
- suitable for MiniTec profiles, connection cable integrated (2 m) and D-Sub connector (longer cable lengths on request up to 20 m).

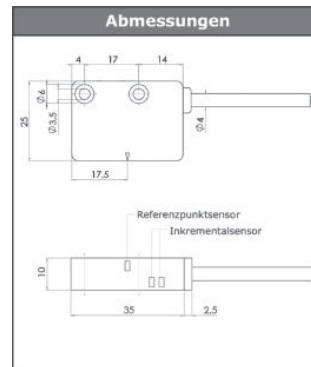

Magnetic Tape Part no. 33.0028/0

Technical Data / delivery

- Magnetic tape for sticking to MiniTec profiles incl. Stainless steel masking tape
- Length max. 80 m, width 10 mm (option: Band width 5 mm for gluing into the profile groove)

Application

- For all MiniTec linear guides with rails made of system profiles
- Length measuring stops
- Material feed

Mounting

- Stick magnetic tape to profile surface, glue masking tape onto magnetic tape.
- Attach sensor to carriage
- Distance to the magnetic tape: 1.1 ± 0.9 mm

Please specify desired magnetic tape length (round up to full meters)



PNEUMATIC SYSTEM

Optically attractive and economical solutions are possible with simultaneous use of the construction profiles as an air duct. The MiniTec standard profiles are particularly well suited for compressed air guidance. Commercially available connections can be used without special connection components.

All standard profiles with round corner holes can be used as compressed air lines. Bore Ø 11.7 can be drilled to G 1/4 to accommodate pneumatic connections or screw plugs. Air extraction at any point.

All MiniTec standard profiles can be used as a single or multi-chamber system. Connections are possible at any point. Maximum pressure for round chambers (Ø 11.7) 20 bar, otherwise max. 8 bar.

Usable cavities for compressed air ducts

All area information in mm²

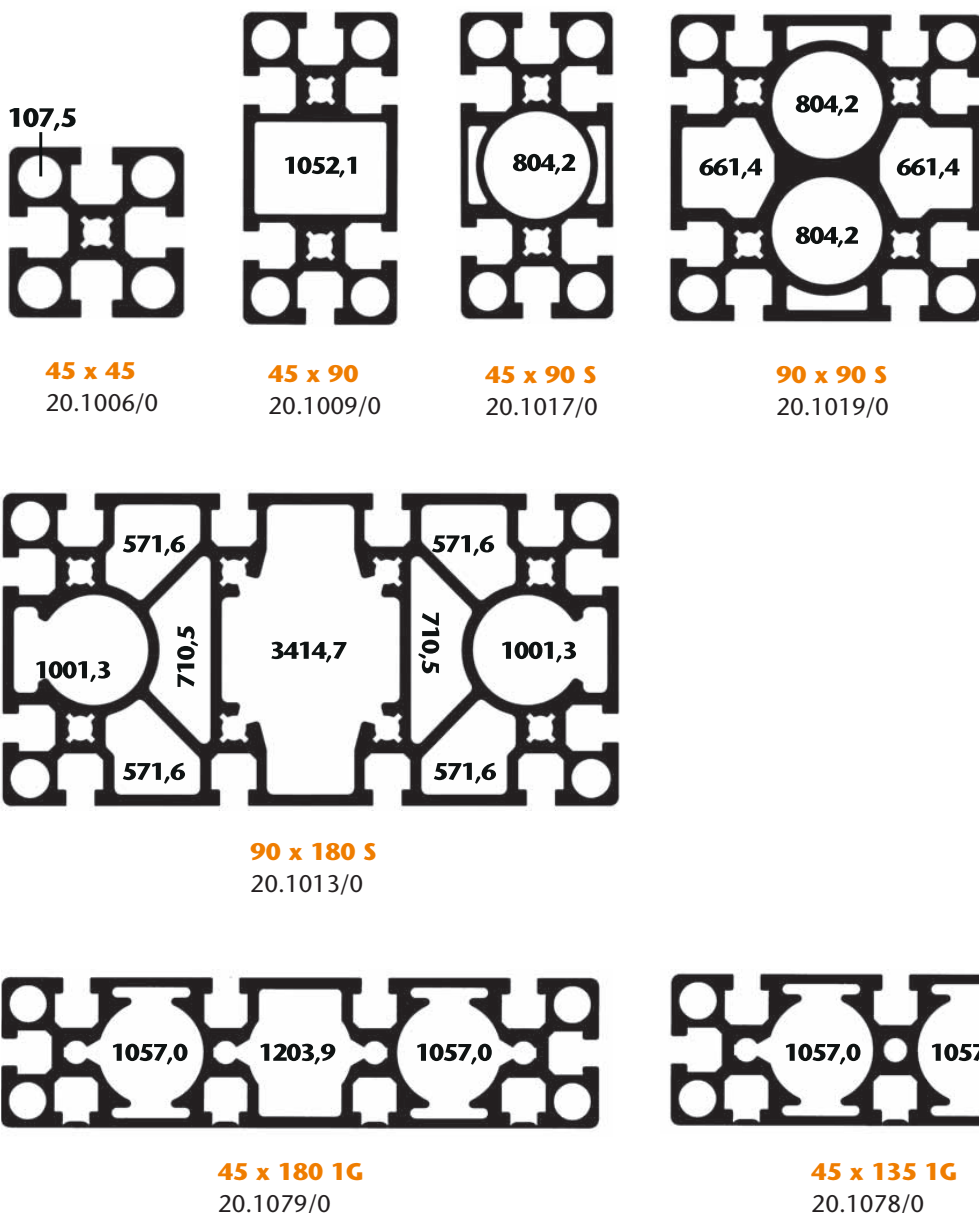

PNEUMATIC SYSTEM

PNEUMATIC-PLATE 45, 45 x 90 and 90

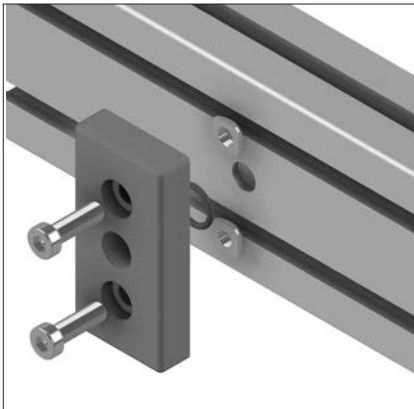

Thread	WEIGHT	Part no.
G 1/8"	0,170 kg	24.1107/0
G 1/4"	0,168 kg	24.1107/2
G 3/8"	0,165 kg	24.1107/3

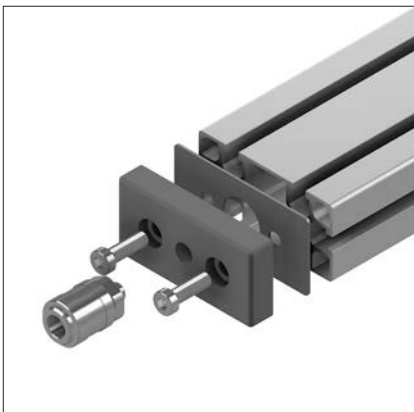

Thread	WEIGHT	Part no.
G 1/8"	0,181 kg	24.1105/0
G 1/4"	0,178 kg	24.1105/2
G 3/8"	0,174 kg	24.1105/3

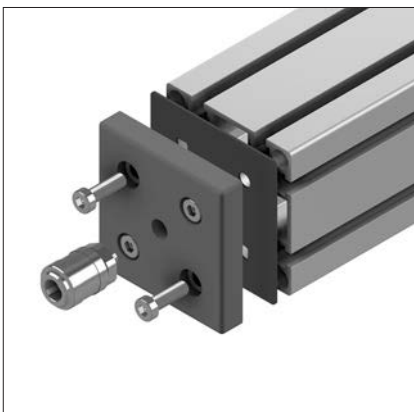

Thread	WEIGHT	Part no.
G 1/8"	0,434 kg	24.1106/0
G 1/4"	0,429 kg	24.1106/2
G 3/8"	0,421 kg	24.1106/3

PNEUMATIC-PLATE 45

Technical Data/Items Supplied

- Die-cast aluminum, powder-coated grey
- 1x O-Ring
- with fastening material

Application

- Side connection for compressed air supply or removal on profiles 45 x 90 and 90 x 90

Assembly

- mount with fastening material of items supplied
- Insert bore Ø 12 mm in the center of the profile

PNEUMATIC-PLATE 45 X 90

Technical Data/Items Supplied

- Die-cast aluminum, powder-coated grey
- with sealing plate made of NBR
- with fastening material

Application

- Closure of the hollow chamber ends of profiles 45 x 90 for connection of pneumatic connections

Assembly

- Apply sealing plate
- with fastening material from items supplied screw on 2 central holes Ø 7.5 mm (tightening torque 12 Nm)

PNEUMATIC PLATE 90

Technical Data/Items Supplied

- Die-cast aluminum, powder-coated grey
- with sealing plate made of NBR
- with fastening material

Application

- Closure of the hollow chamber ends of profiles 90 x 90 for connection of pneumatic connections

Mounting

- Apply sealing plate
- with fastening material from scope of supply screw on 4 central holes Ø 7.5 mm (tightening torque 12 Nm)

PLUG G1/4"

Part no.

24.1104/0

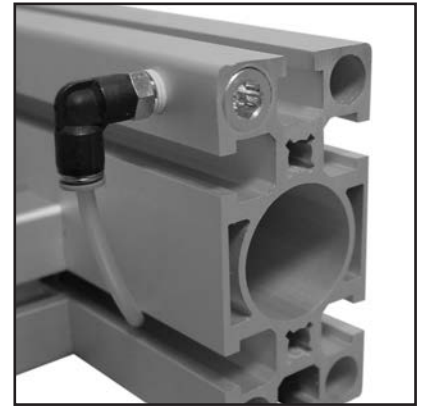
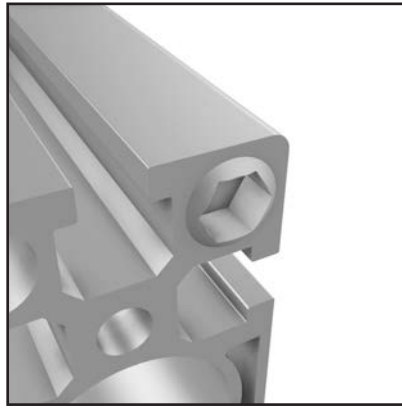
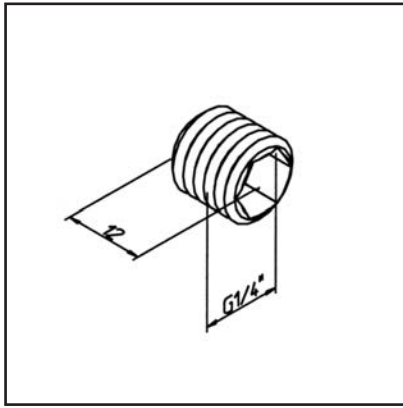
**TECHN. DATA / ITEMS SUPPLIED**

- Brass
- Weight = 0.005 kg/piece

APPLICATIONS

- Closure for profile chambers \varnothing 11,7 mm

ASSEMBLY

- Cut Thread G 1/4" in central hole d 11.7.
- Screw in the plug by using sealing tape

QUICK CONNECTOR 1/8

Part no.

24.1109/0

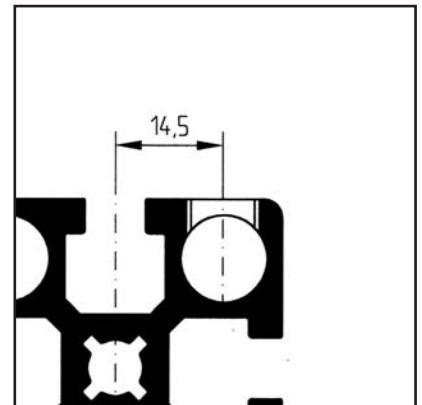
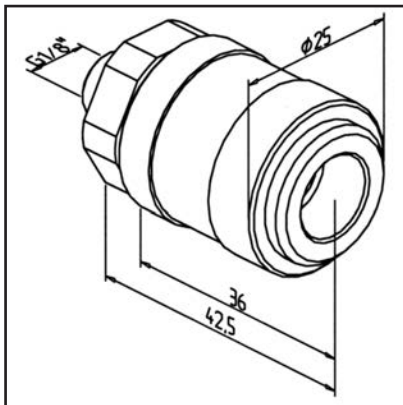
**TECHN. DATA / ITEMS SUPPLIED**

- Brass, nickel-plated
- NW 7 mm
- Connecting thread G 1/8", SW 22
- Weight = 0.087 kg/piece

APPLICATIONS

- To connect directly to the profile panel or frontally at the bore \varnothing 11.7

ASSEMBLY

- Thread G 1/8 in profile face, distance thread centre from centre of profile groove: 14.5 mm

QUICK CONNECTOR 1/4

Part no.

24.1110/0

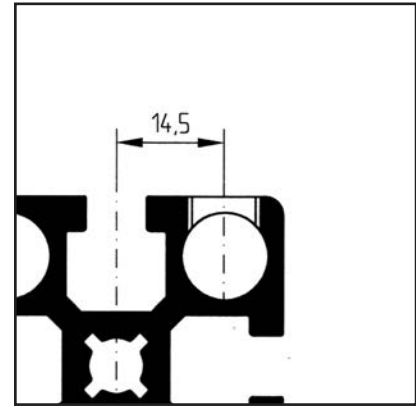
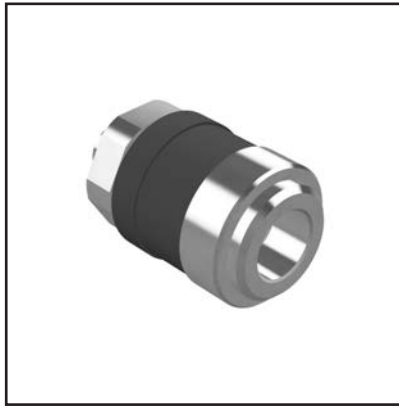
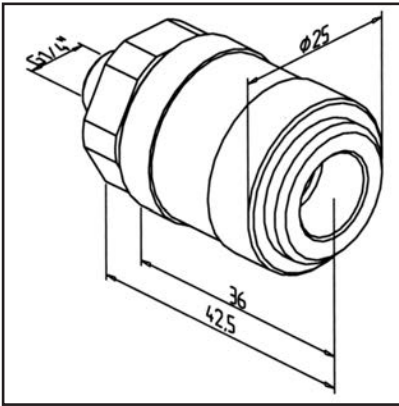

TECHN. DATA / ITEMS SUPPLIED

- Brass, nickel-plated
- NW 7 mm
- Connecting thread G 1/4", SW 22
- Weight = 0.087 kg/piece

APPLICATIONS

- To connect directly to the profile panel or frontally at the bore \varnothing 11.7

ASSEMBLY

- Thread G 1/4 in profile face, distance thread centre from centre of profile groove: 14.5 mm

PNEUMATIC END PLATE 45 X 90

Part no.

24.1105/7

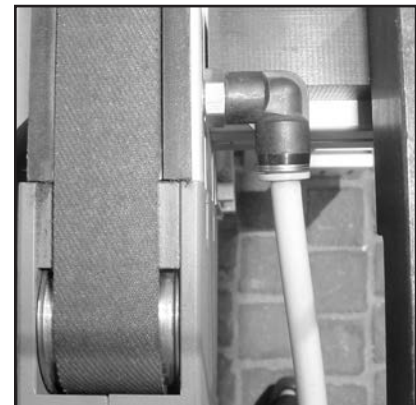
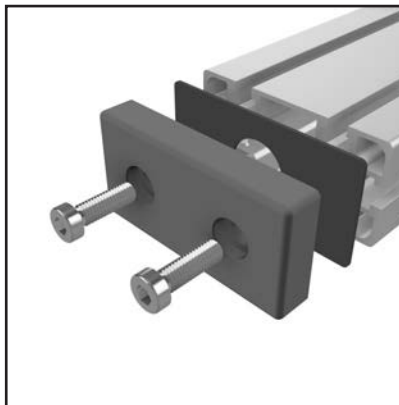
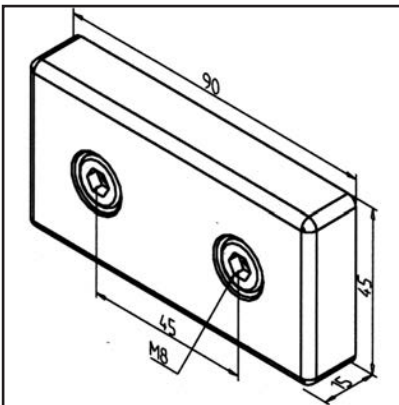

TECHN. DATA / ITEMS SUPPLIED

- Aluminium, Pressure die-casting, powder-coated, grey
- With sealing plate of NBR, black
- Fastening kit
- Weight = 0.180 kg/piece

APPLICATIONS

- Closing of chamber ends of profiles 45 x 90

ASSEMBLY

- Insert sealing plate
- Screw in with fastening material from items supplied.

PNEUMATIC END PLATE 90 X 90

Part no.

24.1106/7

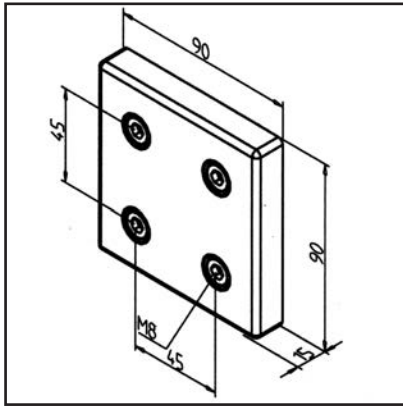
**TECHN. DATA / ITEMS SUPPLIED**

- Aluminium, Pressure die-casting, powder-coated, grey
- With sealing plate of NBR, black
- Fastening kit
- Weight = 0.430 kg/piece

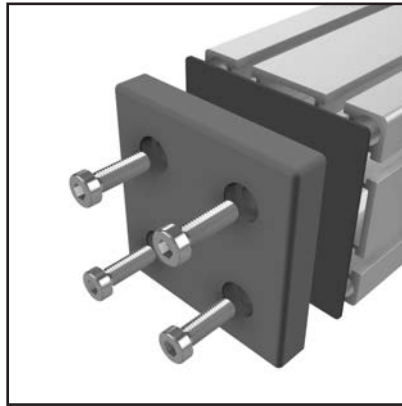
**APPLICATIONS**

- Closing of chambers of profiles 90 x 90 for connection of pneumatic couplings

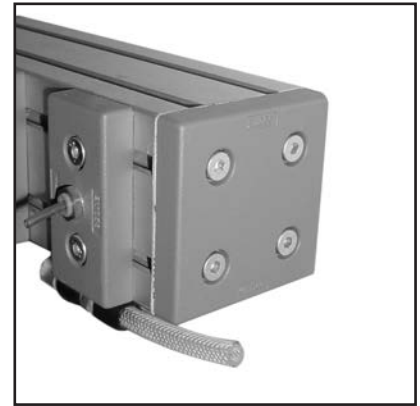
**ASSEMBLY**

- Insert sealing plate
- Screw in with fastening material from items supplied.

PNEUMATIC LIFTING UNIT 15

Part no.

24.1201/0

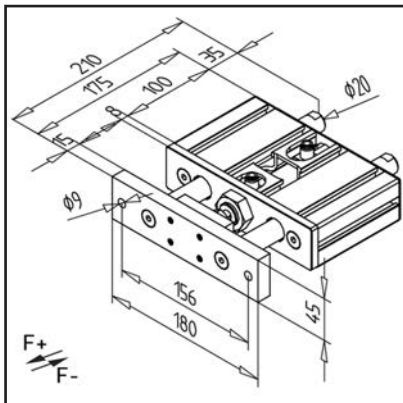
**TECHN. DATA / ITEMS SUPPLIED**

- Incorporated into profile 45 x 180
- Overall cylinder size \varnothing 25 mm
- Guide shafts \varnothing 20 mm
- Fully assembled with double acting pneumatic cylinder
- F+ at 6 bar = 256 N
- F- at 6 bar = 220 N
- Stroke = 15 mm
- Weight = 3.405 kg/piece

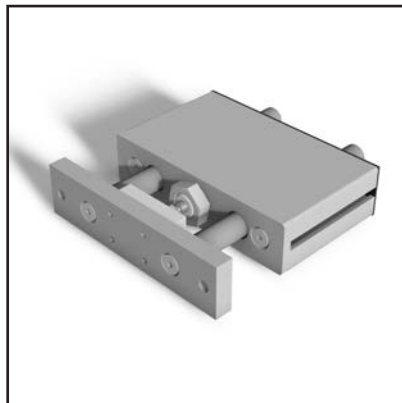
**APPLICATIONS**

- Lifting and lowering of loads
- Attachment for grips or similar
- Positioning of parts

**ASSEMBLY**

- with mounting angle bracket on profile construction
- Other stroke lengths on request

PNEUMATIC LIFTING UNIT 50

Part no.

24.1205/0

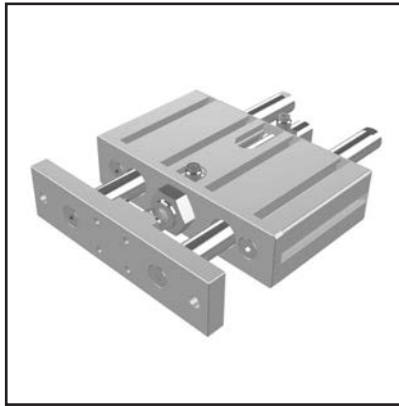
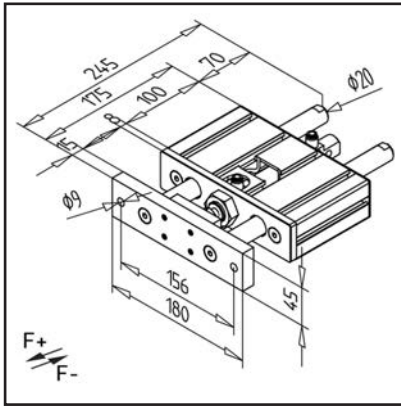

TECHN. DATA / ITEMS SUPPLIED

- Incorporated into profile 45 x 180
- Overall cylinder size \varnothing 25 mm
- Guide shafts \varnothing 20 mm
- Fully assembled with double acting pneumatic cylinder
- F+ at 6 bar = 265 N
- F- at 6 bar = 220 N
- Stroke = 50 mm
- Weight = 3.452 kg/piece

APPLICATIONS

- Lifting and lowering of loads
- Attachment for grips or similar
- Positioning of parts

ASSEMBLY

- with mounting angle bracket on profile construction
- Other stroke lengths on request

PNEUMATIC LIFTING UNIT 100

Part no.

24.1210/0

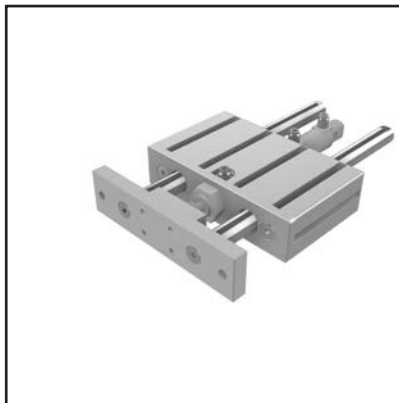
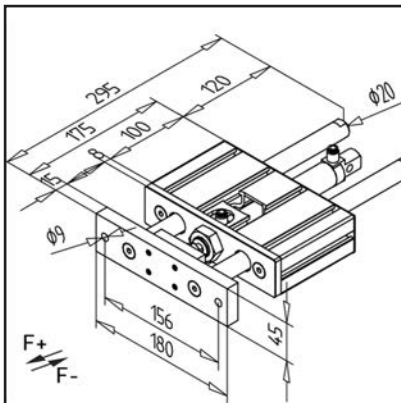

TECHN. DATA / ITEMS SUPPLIED

- Incorporated into profile 45 x 180
- Overall cylinder size \varnothing 25 mm
- Guide shafts \varnothing 20 mm
- Fully assembled with double acting pneumatic cylinder
- F+ at 6 bar = 265 N
- F- at 6 bar = 220 N
- Stroke = 100 mm
- Weight = 3.507 kg/piece

APPLICATIONS

- Lifting and lowering of loads
- Attachment for grips or similar
- Positioning of parts

ASSEMBLY

- with mounting angle bracket on profile construction
- Other stroke lengths on request

HYDRAULICS

Items supplied

- Hydraulic pump for 1 to 6 cylinders
- Alternatively with hand crank or electric drive
- Add-on or built-in cylinders with 150 - 500 mm stroke length
- 5 mm stroke per crank revolution or 15mm/sec with electrical drive
- Hydraulic hoses PA 4 mm
- Cylinders are single-acting
- Minimum load for retraction approx. 5 kg
- Temperature range from -20°C bis + 45°C

Application

- Lifting, lowering, tilting tables, countertops, desks, workbenches, fixtures, etc.

Assembly

- Tighten the pump at the appropriate place in the construction with screws M6 to the profile groove
- Mount built-in cylinder in aluminum profile "S"
- Mount the add-on cylinder to the profile groove using the adapter plate

Available special versions and equipment

- Fasteners for pumps according to customer requirements
- Mounting parts for mounting cylinder according to customer requirements
- Fastening kit 45 for installation cylinder
part no. 27.0005/0 for all profiles with hollow chamber \varnothing 32 except for profile 90 x 90 S and 90 x 180 s.
 For these, please use the fixing kit 90
part no. 27.0006/0
- Service kit with oil, fittings, special wrench, tube cutter and filling syringe

When working on the hydraulics, great care should be taken. In order to prevent air bubbles from forming in the system, we recommend having this work carried out by us.

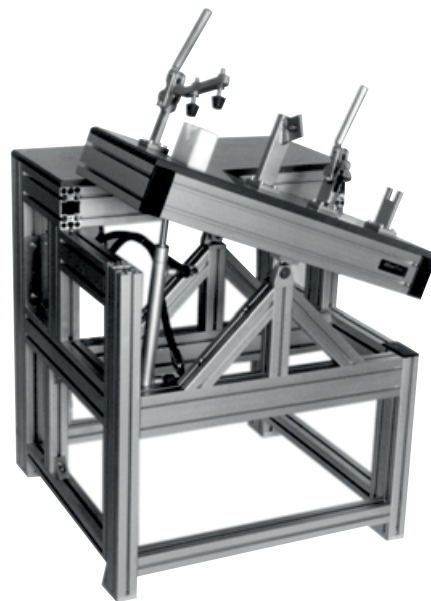

HYDRAULICS



Complete system with add-on cylinder LA - manual

PUMP	PA	PA	PB	PB	PB	PB
System load	150 kg	300 kg	350 kg			
Number of cylinders	1	2	3	4	5	6
LA 150 man.	27.0118/1	27.0118/2	27.0118/3	27.0118/4	27.0118/5	27.0118/6
LA 200 man.	27.0122/1	27.0122/2	27.0122/3	27.0122/4	27.0122/5	27.0122/6
LA 300 man.	27.0126/1	27.0126/2	27.0126/3	27.0126/4	27.0126/5	27.0126/6
LA 400 man.	27.0130/1	27.0130/2	27.0130/3	27.0130/4	27.0130/5	27.0130/6
LA 500 man.	27.0134/1	27.0134/2	27.0134/3	27.0134/4	27.0134/5	27.0134/6

Complete system with add-on cylinder LA - electric

LA 150 elektr.	27.0119/1	27.0119/2	27.0119/3	27.0119/4	27.0119/5	27.0119/6
LA 200 elektr.	27.0123/1	27.0123/2	27.0123/3	27.0123/4	27.0123/5	27.0123/6
LA 300 elektr.	27.0127/1	27.0127/2	27.0127/3	27.0127/4	27.0127/5	27.0127/6
LA 400 elektr.	27.0131/1	27.0131/2	27.0131/3	27.0131/4	27.0131/5	27.0131/6
LA 500 elektr.	27.0135/1	27.0135/2	27.0135/3	27.0135/4	27.0135/5	27.0135/6



Complete system with built-in cylinder LB - manual

PUMP	PA	PA	PB	PB	PB	PB
System load	150 kg	300 kg	350 kg			
Number of cylinders	1	2	3	4	5	6
LB 150 man.	27.0120/1	27.0120/2	27.0120/3	27.0120/4	27.0120/5	27.0120/6
LB 200 man.	27.0124/1	27.0124/2	27.0124/3	27.0124/4	27.0124/5	27.0124/6
LB 300 man.	27.0128/1	27.0128/2	27.0128/3	27.0128/4	27.0128/5	27.0128/6
LB 400 man.	27.0132/1	27.0132/2	27.0132/3	27.0132/4	27.0132/5	27.0132/6
LB 500 man.	27.0136/1	27.0136/2	27.0136/3	27.0136/4	27.0136/5	27.0136/6

Complete system with built-in cylinder LB - electric

LB 150 elektr.	27.0121/1	27.0121/2	27.0121/3	27.0121/4	27.0121/5	27.0121/6
LB 200 elektr.	27.0125/1	27.0125/2	27.0125/3	27.0125/4	27.0125/5	27.0125/6
LB 300 elektr.	27.0129/1	27.0129/2	27.0129/3	27.0129/4	27.0129/5	27.0129/6
LB 400 elektr.	27.0133/1	27.0133/2	27.0133/3	27.0133/4	27.0133/5	27.0133/6
LB 500 elektr.	27.0137/1	27.0137/2	27.0137/3	27.0137/4	27.0137/5	27.0137/6

HYDRAULICS

HYDRAULIC PUMPS PA FOR 1-2 CYLINDERS
 HYDRAULIC PUMPS PB FOR 3-6 CYLINDERS
 ADD-ON CYLINDER LA

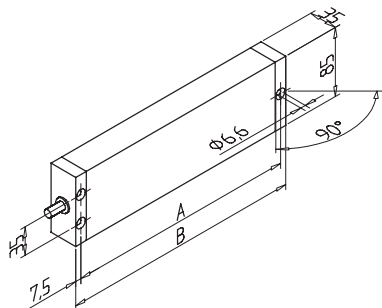

Hydraulic pumps PA for 1-2 cylinders

TYPE	Stroke H mm	Dimension A mm	Dimension B mm
PA 150	150	283,5	298,5
PA 200	200	343,5	358,5
PA 300	300	465,5	480,5
PA 400	400	585,5	600,5
PA 500	500	707,5	722,5

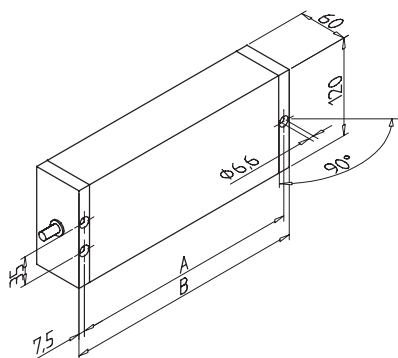

Hydraulic pumps PB for 3-6 cylinders

TYPE	Stroke H mm	Dimension A mm	Dimension B mm
PB 150	150	283,5	298,5
PB 200	200	343,5	358,5
PB 300	300	465,5	480,5
PB 400	400	585,5	600,5
PB 500	500	707,5	722,5

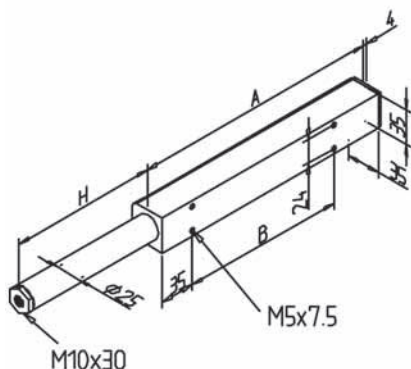

Add-on cylinder LA

TYPE	Stroke H mm	Length A mm	Length B mm	lateral load kg max.
LA 150	150	252	165	130
LA 200	200	317	240	97
LA 300	300	442	340	65
LA 400	400	542	340	48
LA 500	500	667	450	29

For attachment to a wide variety of constructions using adapter plates.

MOUNTING CYLINDER LB, FASTENING KIT 45 FOR MOUNTING CYLINDER, FASTENING KIT 90 FOR MOUNTING CYLINDER

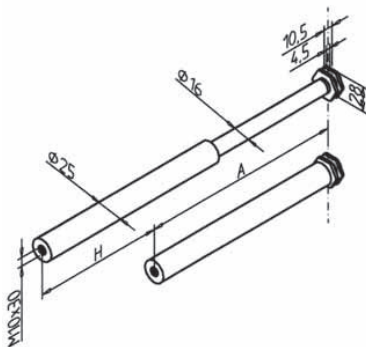

Add-on cylinder LB

TYPE	Stroke H mm	Length A mm	lateral load kg max.
LB 150	150	235	130
LB 200	200	300	97
LB 300	300	425	65
LB 400	400	525	48
LB 500	500	650	29

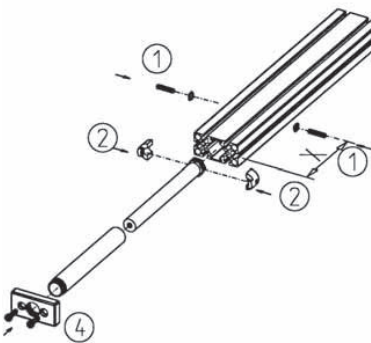

Fastening kit 45 for installation cylinder (Part No. 27.0005/0)

Suitable for all stroke lengths as well as for profile 45x90S, 45x135G and 45x180G

Assembly

1. Drill profile according to measurement table (dimension X) Ø 8,5 mm
2. Place 2 holders on cylinder and insert in profile chamber Ø 32
3. Insert the centering hole into the mounting pieces (through hole distance X), then fix with threaded pin
4. Screw guide tube into connection plate, insert in profile and fasten

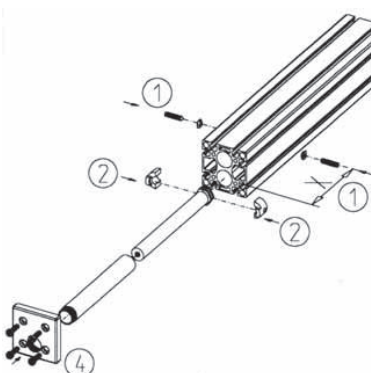
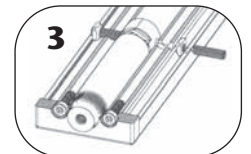

Fastening kit 90 for installation cylinder (Part No. 27.0006/0)

Suitable for all stroke lengths as well as for profile 90x90s, 90x180

Assembly

1. Drill profile according to measurement table (dimension X) Ø 8,5 mm
2. Place 2 holders on cylinder and insert in profile chamber Ø 32
3. Insert the centering hole into the mounting pieces (through hole distance X), then fix with threaded pin
4. Screw guide tube into connection plate, insert in profile and fasten

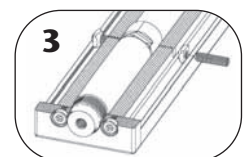

Measurements for fastening kit 45 and 90

Cylinder	LB 150	LB 200	LB 300	LB 400	LB 500
Dimension X (mm)	224	289	414	514	639



2.1

LINEAR MODULE LMS 90

266



2.2

LINEAR MODULE LMZ 90

271



2.3

LINEAR SYSTEM LR

273



2.4

MINI-ADJUSTING UNITS

328



2.5

ADJUSTING UNITS

332



2.6

SLIDING GUIDES

336



2.7

LINEAR SYSTEM LB

344

LINEAR MODULE LMS 90

The linear module LMS 90 is designed for applications requiring precision and durability with minimal installation space. It is constructed for a stroke up to 2845 mm. The guide with the standard grid dimension 90 x 90 mm of our modular system is based on highly accurate rail systems which are integrated into a profile system. The high performance linear rail guides are built to perform 10000 km.

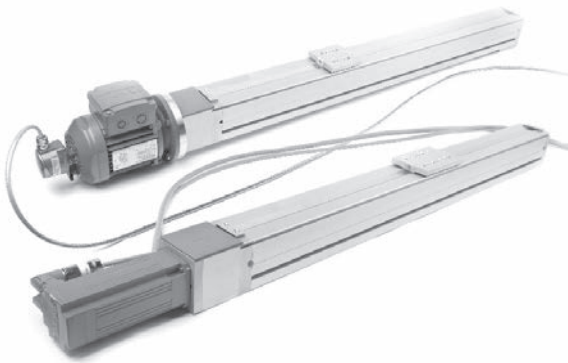

GUIDANCE OPTIONS

- Heavy-duty rail guides with permanent lubrication, versions S1 and S2
- Plastic sliding guides for very economical applications (version G)

COP VERSIONS

- Ball screw tolerance class T7, right-handed, axial clearance max. 0.04 mm, repeatability 52 µm / 300 mm
- Trapezoidal thread spindle 16x4, optional right-handed biased with increased accuracy

For all units, the spindle nuts are designed for relubrication.

SPECIFICATIONS

- Compact support profile 90x90 with standard profile grooves, compatible with all MiniTec construction profiles
- Fully enclosed module, guide groove covered with stainless steel tape
- Guides and spindle easily accessible through removable cover profiles
- Special grooves for external mounting of position detection sensors
- Easy installation of external switches on lateral profile grooves
- Carriage made of aluminum, precision-machined on all sides, prepared for attachments with 4 or 6 connecting threads M8 at intervals of 45 mm
- Travel up to 2845 mm
- 2 bearing units with precision ball bearings, lubricated for life, with tenon Ø 10 mm
- Optional version with keyway or adapter plate machined according to engine specification

TECHNICAL DATA

Model series	Spindle	Execution	Number Linear slide	Part no.	max. Traversing	Car length WL	max. Stroke
LMS 90	T 16x4	G	4	28.1001/0	0,03 m/s	135 mm	1845 mm
LMS 90	K 16x5	S1	2	28.1000/0	0,25 m/s	90 mm	2845 mm
LMS 90	K 16x10	S1	2	28.1000/1	0,5 m/s	90 mm	2845 mm
LMS 90	K 16x16	S1	2	28.1000/2	0,8 m/s	90 mm	2845 mm
LMS 90	K 16x5	S2	4	28.1002/0	0,25 m/s	135 mm	2800 mm
LMS 90	K 16x10	S2	4	28.1002/1	0,5 m/s	135 mm	2800 mm
LMS 90	K 16x16	S2	4	28.1002/2	0,8 m/s	135 mm	2800 mm

Execution	Load rating N		Permissible stat. tilting moments (Nm)		
	Cdyn	Cstat	Mx	My	Mz
S1	7620	11180	54	54	54
S2	15240	22360	108	108	108
G	2800	2800	22	22	22

Spindle

- Acme screw K
- Ballscrew T

Guidance

- 2 sliding guides each with 2 linear slides Gr. 15 G (S1)
- 2 rail guides each with 1 linear slide Gr. 15 (S2)
- 2 rail guides with 2 linear slides Gr. 15 (S2)

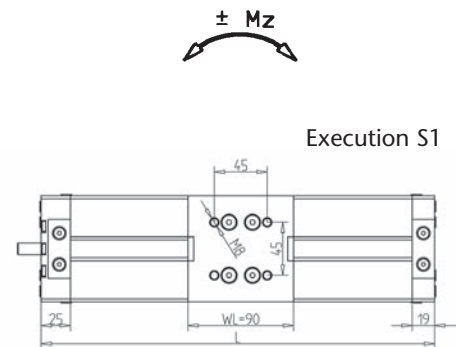
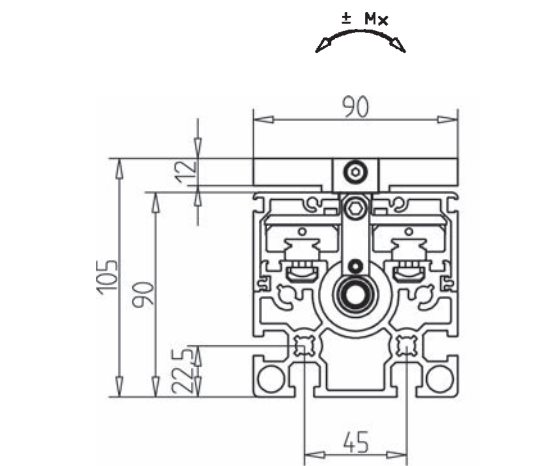

Execution S1

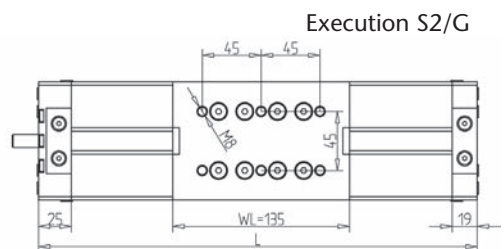
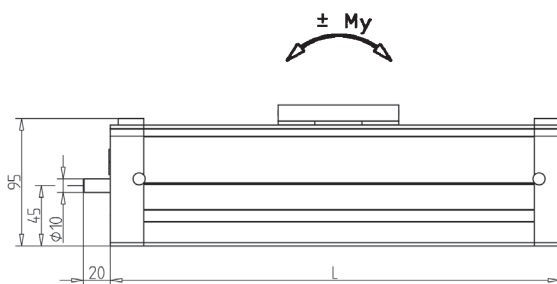

Execution S2/G

TECHNICAL DATA

Maximum speed depending on stroke

Speed (rpm.)

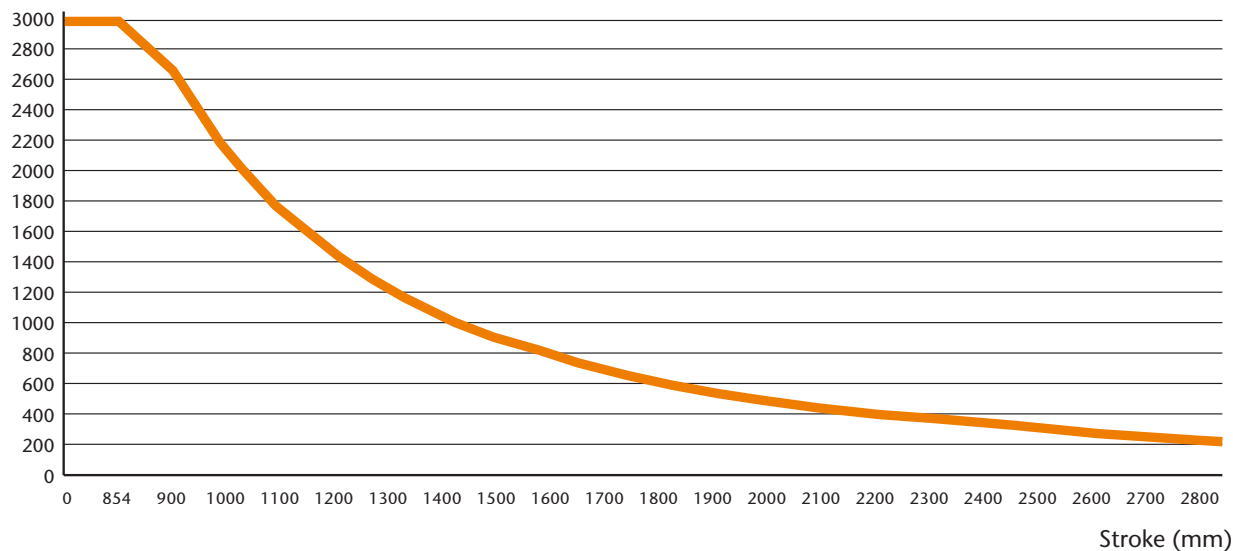

On request, the unit can also be equipped with an internal spindle support. As a result, the speed can be increased considerably with a corresponding stroke.

As a guideline can be set:

Spindle support simple Part no.: 28.1050/0 - nmax x 2

When using the simple spindle support, the stroke is shortened by 25mm

Spindle support double Part no.: 28.1051/0 - nmax x 3

When using the double spindle supports, the stroke is shortened by 60 mm

Calculation of the maximum speed (nmax.):

$$n_{\max} = \frac{1,963 \times 10^9}{(H-45)^2}$$

ORDERING

Please enter the article number plus the desired stroke length H or the total length L. (xx.xxxx / x + stroke length or total length)

- Overall length (L) = stroke length (H) + carriage length (WL) + 50 mm
- Stroke (H)
- Car length (WL)

If you have any questions about the product or the ordering process, please do not hesitate to contact our team of Lineartechnik by phone +49 (0) 6373 8127-0 or by e-mail info@minitec.de.

ENGINE KITS & DRIVE PACKAGES

ENGINE KITS FOR LMS 90

Motor fastening kit LMS 90 DRM

(MiniTec Part No: 28.1040/0)

Motor fastening kit LMS for three-phase motor (for drive package with three-phase asynchronous motor, MiniTec Part no. 33.1010/0 bzw. 33.1020/0), without motor.

Items Supplied

- Coupling housing made of profile incl. adapter plate
- Coupling
- Screws and equipment

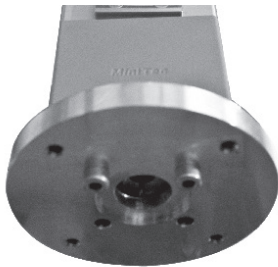
**Motor fastening kit LMS 90 SERVO**

(MiniTec part no: 28.1041/0)

Motor fastening kit LMS for servomotors (for drive package with synchronous servomotor, MiniTec Part no. 33.1030/0), without motor.

Items Supplied

- Coupling housing made of profile incl. adapter plate
- Coupling
- Screws and equipment

Options

- Adapted adapter plates and couplings for special motors



DRIVE PACKAGES FOR LMS 90

DRIVE PACKAGE LMS 90 DRM-POSI

(MiniTec Part No: 33.1020/0)

Three-phase asynchronous motor with encoder feedback with drive inverter for table positioning

Items Supplied

- Three-phase asynchronous motor 0.18kW; 1320 1 / min at 50Hz, version with pulse generator and temperature sensor
- Motor cable, length 5m
- Encoder cable, length 5m
- Drive inverter MDX61B for table positioning via IO for customer installation in the control cabinet
- 2 pieces of inductive proximity switch for T-slot for axial end position (NC)
- 1 piece of inductive proximity switch for T-slot for axial end position (NO) including motor fastening kit LMS 90 DRM (Part No .: 28.1040/0)

DRIVE PACKAGE LMS 90 DRM-ECO

(MiniTec Part No: 33.1010/0)

Three-phase asynchronous motor without encoder feedback with frequency converter for easy positioning via switch

Items Supplied

- Three-phase asynchronous motor 0.18kW; 1320 1 / min at 50Hz, version with temperature sensor
- Motor cable, length 5m
- Drive inverter MC07B, control via IO for customer installation in the control cabinet
- 2 pieces of inductive proximity switch for T-slot for axial end position (NC)
- 1 piece inductive proximity switch for T-slot for axial end position (NO)
- including motor fastening kit LMS 90 DRM (Part no: 28.1040/0)

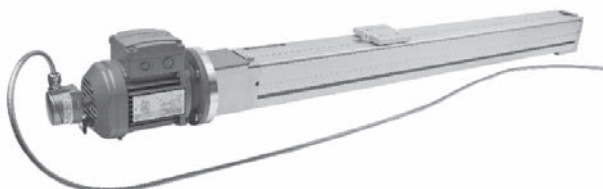

ENGINE KITS & DRIVE PACKAGES

DRIVE PACKAGES FOR LMS 90

DRIVE PACKAGE LMS 90 SERVO

(MiniTec Part No: 33.1030/0)

Synchronous servo motor with drive inverter for dynamic applications for table positioning

Items Supplied

Synchronous servo motor with 2.4 Nm nominal torque, 3000 1 / min, version with resolver and temperature sensor

Motor cable, length 5m

Encoder cable, length 5m

Drive inverter MDX61B for table positioning via IO for customer installation in the control cabinet

2 pieces of inductive proximity switch for T-slot for axial end position (NC)

1 piece inductive proximity switch for T-slot for axial end position (NO)

including motor fastening kit LMS 90 Servo (Part No: 28.1041/0)

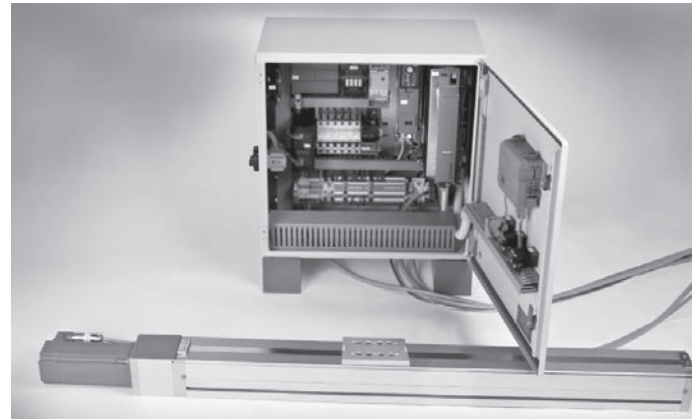
**Options**

Motor with holding brake

Motor version with absolute encoder

PROFIBus / PPOFIsafe / PROFINET / Ethercat Interface cards for the drive inverter

Additional sensors e.g. additional creep / stop positions

READY-TO-INSTALL POSITIONING SYSTEMS

The new high-performance module LMS 90 is also available as a ready-to-install system with drive package and control unit.

A suitable complete package is available for every task - from the particularly economical ECO design to the highly dynamic servo drive. Upon request, we also take over the commissioning and application programming for you.

Thanks to the standardized profile geometry, the LMS axes can be variably combined with each other or with all other linear modules from MiniTec to form multi-axis systems.

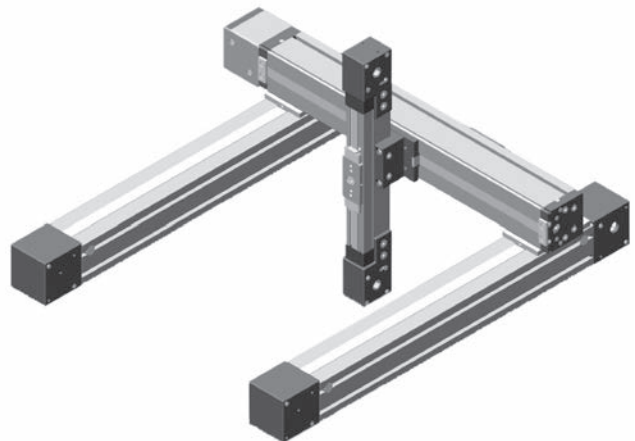

LINEAR MODULE LMZ 90 WITH TIMING BELT DRIVE

(Part no. 28.0400/0)

- Compact beam profile, with standard profile grooves, compatible with MiniTec construction profiles
- Integrated rail guide size 20
- With 2 slides covered by the timing belt
- Lubrication with intentional lubrication units for mileage up to 10000 km
- Slides made of aluminum, machined on all sides, with integrated timing belt tensioners for attachments with 6 connection threads M8
- 2 deflection units with precision ball bearings, mounted on carrier profile with MiniTec profile connectors, prepared for motor mounting with connecting shaft $\varnothing 17$ mm with feather key, adapter plate according to the desired engine specification processed. Other diameters for drive shafts on request.
- Feed: 200 mm / turn
- Max. permissible belt tension: 3500 N
- Timing belt 25 AT 10, reinforced steel wire, pre-tensioned
- assembled
- Max. travel X = 3,800 mm
- Attachment of switches on side profile grooves with standard components from the MiniTec profile system Travel speed: max. 3 m/s
- Basis weight: 5,200 g
- Weight per 100 mm travel: approx. 800 g



LINEAR MODULE LMZ 90 WITH TIMING BELT DRIVE

(Part no. 28.0400/0)

Delivery forms

- Fully assembled module with connection processing for the desired drive
- Fully assembled module with gearbox and motor to customer specification
- Fully assembled module with gearbox, motor and control according to customer specification

Assembly

- Pick-and-Place
- Gantry robot
- Measuring equipment
- Supply
- Handling facilities

Operating conditions

For self-supporting installation, the maximum permissible deflection from approx 3.5 mm to 4000 mm must be observed. It is recommended - especially at high dynamic load - to support the module at a distance of 300 to 600 mm.

Load rating N		Permissible stat tilting moments Nm		
Cdyn	Cstat	Mx	My	Mz
18800	24400	128	240	128

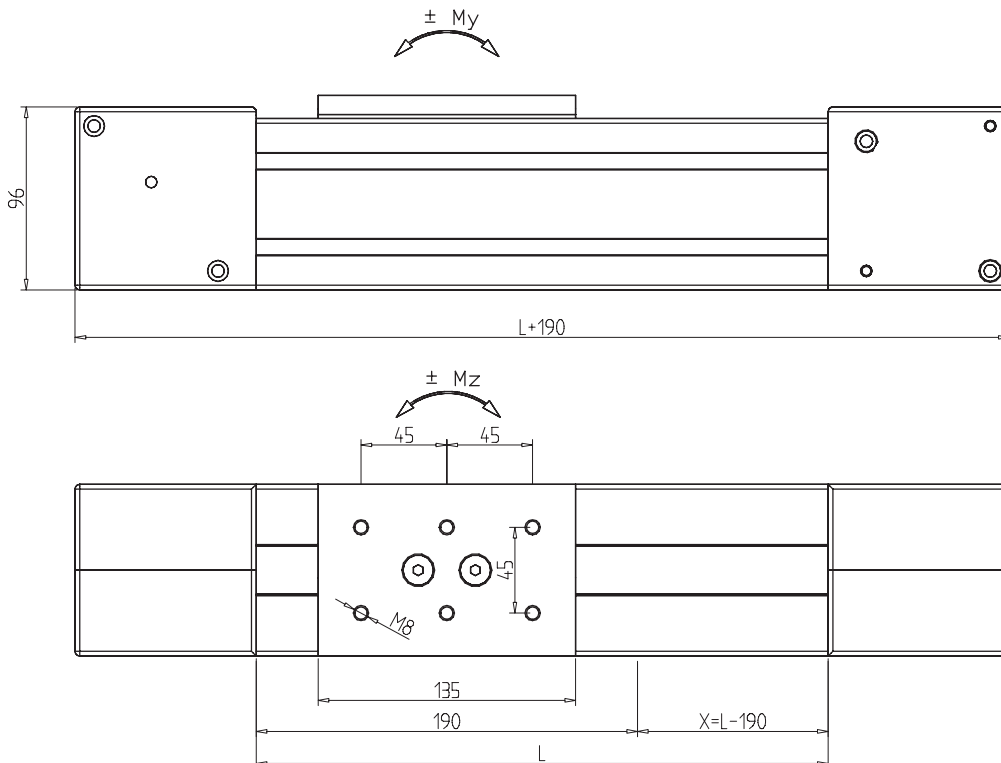
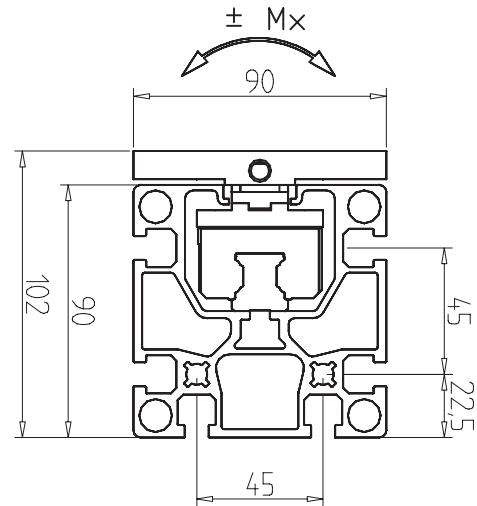

READY-TO-INSTALL MODULES - LINEAR SYSTEM LR

On the following pages you will find our ready-to-install LR modules. For an order, only the stroke/total length and the desired deflection must be defined.

This system is based on double-row profiled rollers made of ball bearing steel and hardened precision shafts made of material 1.1214 (Cf 53). Our carriages are equipped with 2-row profiled rollers whose shaft tracks are designed as Gothic arches. For very high loads, the trolleys can be equipped with any number of track rollers. The profiled rollers are fastened directly to

the carriage plate with steel strips. No special roller profiles are required for the construction of the trolleys. This gives the construction maximum rigidity. The carriages are completely encapsulated, scraper felts are integrated in the cover caps, which simultaneously remove coarse dirt and supply the shafts with lubricant. The felts can be replaced quickly and easily after loosening the lateral screw connection. This advantage has an extremely positive effect, especially in dirty or rough operating conditions.

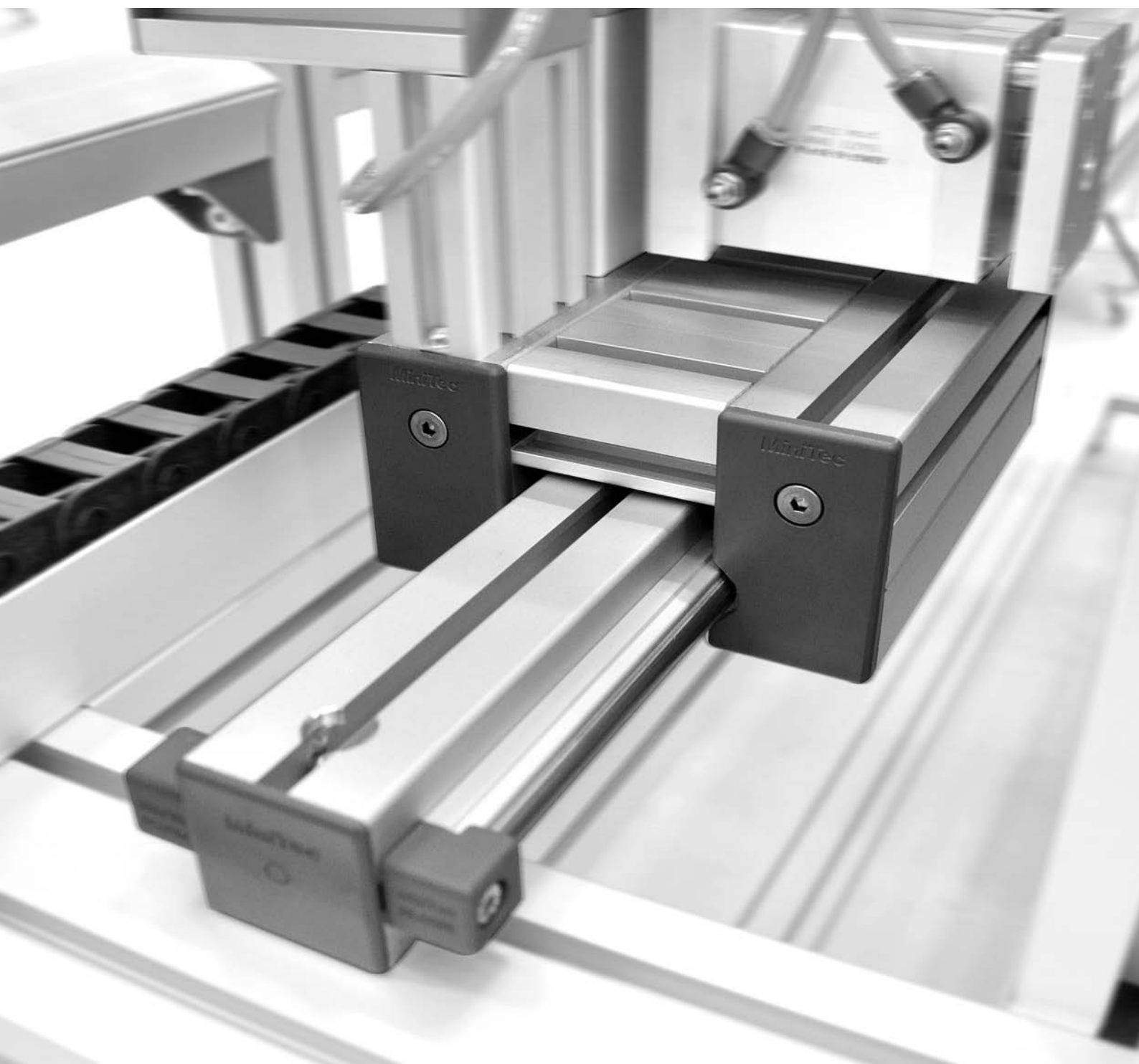

LINEAR AXIS LR 6 Z-45X45R

Part no. 28.0500/0

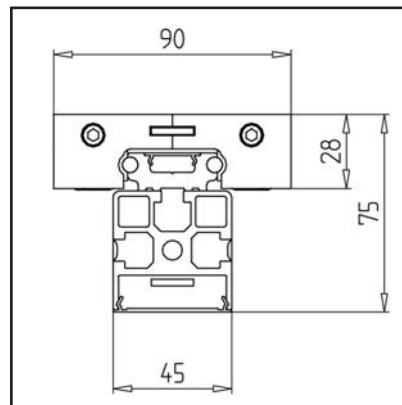
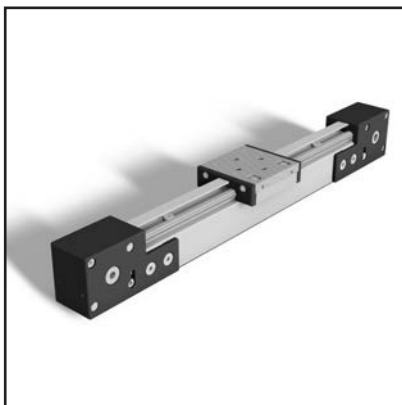
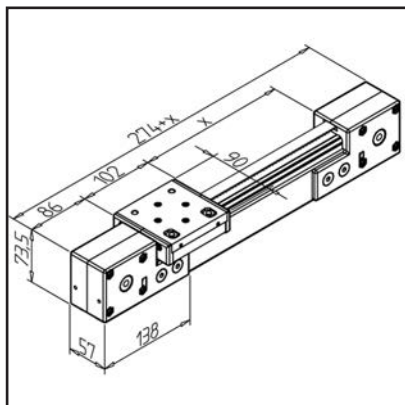

TECHN. DATA / ITEMS SUPPLIED

- Linear guide, ready for use, consisting of:
- 1x rail LR 6 with precision steel shafts h6, Ø 6 mm, on carrier profile 45 x 45 R
- 1x slide LR 6 Z with integrated timing belt admission
- 2x timing belt pulleys
- 1x timing belt 16 AT 5, steel reinforced
- **Please specify stroke length X and reverse unit**
- Stainless version **part no. 28.0500/1**
- Weight = (basic weight) 2.25 kg
- Extra weight = 0.322 kg / 100 mm stroke

APPLICATIONS

- Handling devices
- Measuring devices
- Calibration devices
- Precise guidance of doors or large extracts

ASSEMBLY

- Strap is tensioned over the reversing unit

LINEAR AXIS Z LR 6 - 45X90

Part no. 28.0501/0

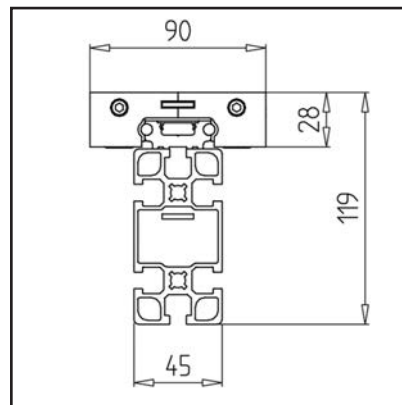
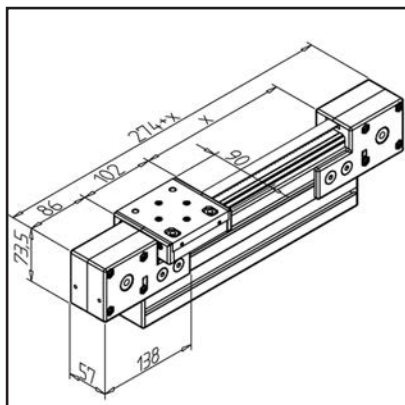

TECHN. DATA / ITEMS SUPPLIED

- Linear guide, ready for use, consisting of:
- 1x rail LR 6 S with precision steel shafts h6, Ø 6 mm, on carrier profile 45 x 90 F
- 1x carriage LR 6 Z with integrated timing belt mounting
- 2x timing belt deflectors
- 1x timing belt 16 AT 5, steel reinforced
- **Please specify stroke length X and reverse unit**
- Stainless version **part no. 28.0501/1**
- Weight = (basic weight) 2.25 kg
- Extra weight = 0.453 kg / 100 mm stroke

APPLICATIONS

- Handling devices
- Measuring devices
- Calibration devices
- Precise guidance of doors or large extracts

ASSEMBLY

- Strap is tensioned over the reversing unit

LINEAR AXIS LR 6 Z COMPACT - 45X45R

Part no.

28.0503/0

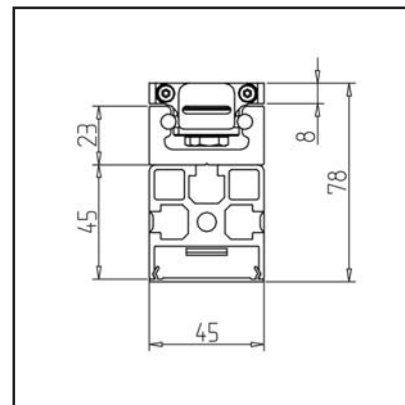
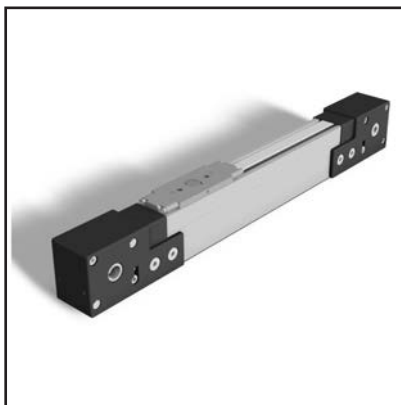
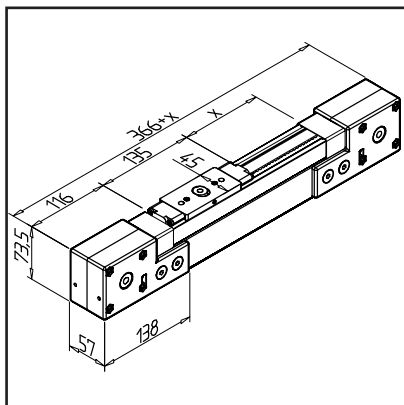
**TECHN. DATA / ITEMS SUPPLIED**

- Linear guide, ready for use, consisting of:
- 1x rail LR 6 compact with precision steel shafts h6, Ø 6 mm, on support profile 45 x 45 R
- 1x carriage LR 6 Z compact with integrated timing belt mount
- 2x timing belt deflectors
- 1x timing belt 16 AT 5, reinforced steel
- **Please specify stroke length X and reverse unit**
- Stainless version **part no. 28.0503/1**
- Weight = (basic weight) 2.977 kg
- Extra weight = 0.407 kg / 100 mm stroke

APPLICATIONS

- Handling devices
- Measuring devices
- Calibration devices

ASSEMBLY

- Strap is tensioned over the reversing unit

LINEAR AXIS LR 6 Z COMPACT - 45X90

Part no.

28.0504/0

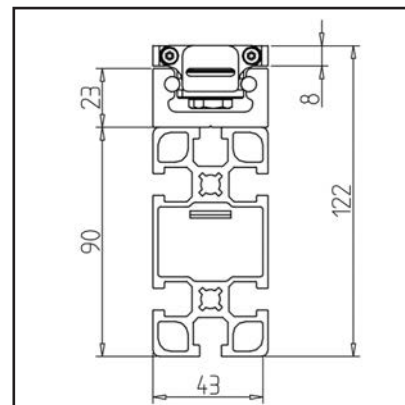
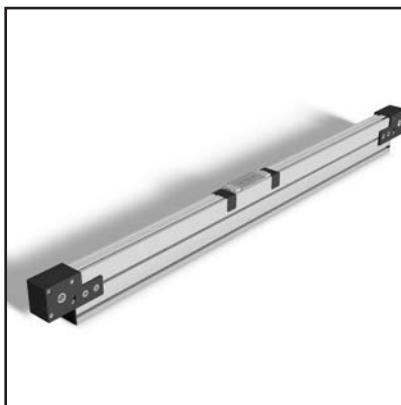
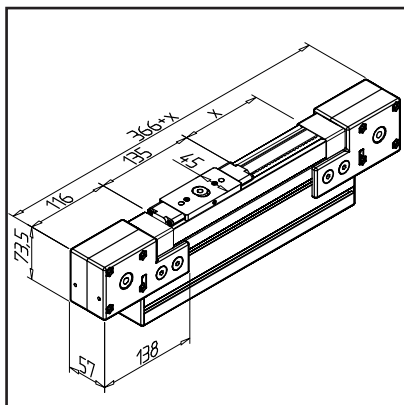
**TECHN. DATA / ITEMS SUPPLIED**

- Linear guide, ready for use, consisting of:
- 1x rail LR 6 with precision steel shafts h6, Ø 6 mm, on carrier profile 45 x 90, 1 Slide LW 6 Z with integrated timing belt admission, 2x timing belt pulleys 1 tooth belt 16 AT 5, steel reinforced
- **Please specify stroke length X and reverse unit**
- Stainless version **part no. 28.0504/1**
- Weight = (basic weight) 3.305 kg
- Extra weight = 0.547 kg / 100 mm stroke

APPLICATIONS

- Handling devices
- Measuring devices
- Calibration devices

ASSEMBLY

- Strap is tensioned over the reversing unit

LINEAR AXIS LR 12 - 45X90

Part no.

28.0600/0

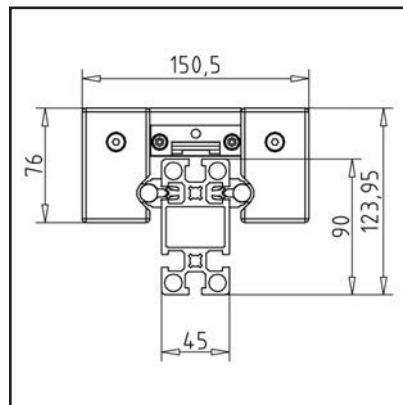
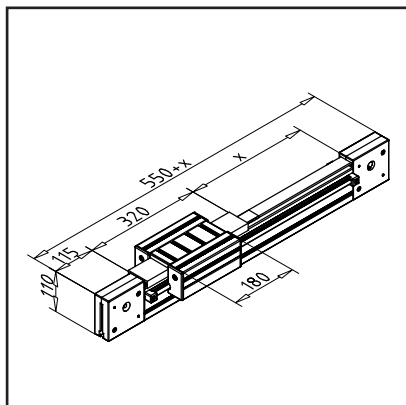

TECHN. DATA / ITEMS SUPPLIED

- Linear guide, ready for use, consisting of:
- 1x rail 45 x 90 H with shaft fixation
- 2x timing belt pulley T45
- 2x timing belt tensioner
- 1x slide LW 45
- 1x timing belt 32AT10
- **Please specify stroke length X and reverse unit**
- Stainless version **part no. 28.0600/1**
- Weight = (basic weight) 7.37 kg
- Extra weight = 0.656 kg / 100 mm stroke

APPLICATIONS

- Handling devices
- Measuring devices
- Calibration devices

ASSEMBLY

- Belt is fastened and tensioned with the aid of timing belt tensioner

LINEAR AXIS LR 12 - 90X90

Part no.

28.0601/0

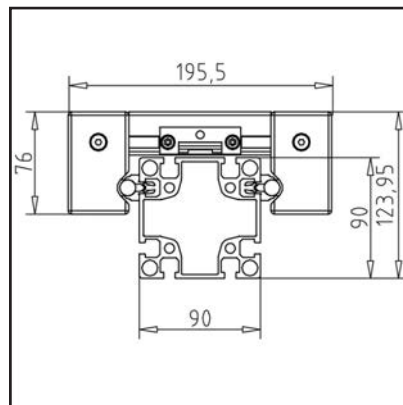
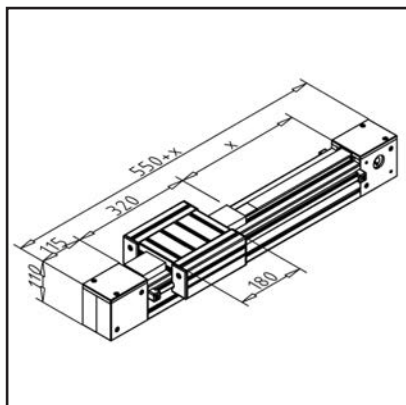

TECHN. DATA / ITEMS SUPPLIED

- Linear guide, ready for use, consisting of:
- 1x rail LR 12 - 90 with shaft fixation
- 2x timing belt pulley T90
- 2x timing belt tensioner
- 1x slide LW 90
- 1x timing belt 32AT10
- **Please specify stroke length X and reverse unit**
- Stainless version **part no. 28.0601/1**
- Weight = (basic weight) 11.65 kg
- Extra weight = 0.827 kg / 100 mm stroke

APPLICATIONS

- Handling devices
- Measuring devices
- Calibration devices

ASSEMBLY

- Belt is fastened and tensioned with the aid of timing belt tensioner

LINEAR AXIS LR 16 - 45X90

Part no.

28.0802/0

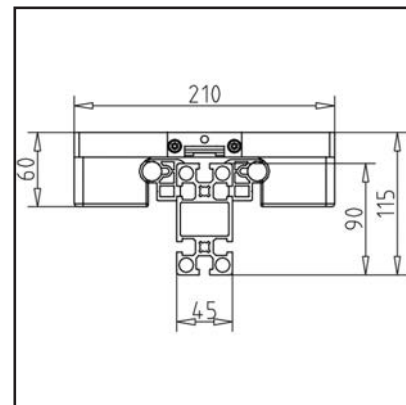
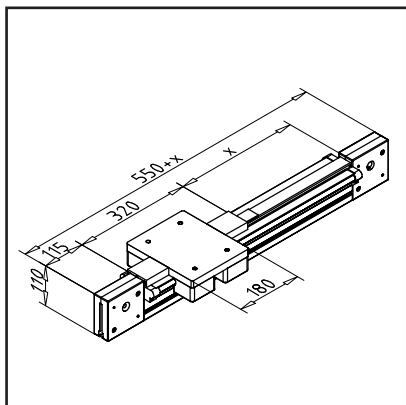
**TECHN. DATA / ITEMS SUPPLIED**

- Linear guide, ready for use, consisting of:
- 1x rail LR 16 - 45x90 with shaft fixation
- 2x timing belt pulley T90
- 2x timing belt tensioner
- 1x slide LR16-45
- 1x timing belt 32AT10
- **Please specify stroke length X and reverse unit**
- Weight = (basic weight) 10.19 kg
- Extra weight = 0.908 kg / 100 mm stroke

APPLICATIONS

- Handling devices
- Measuring devices
- Calibration devices

ASSEMBLY

- Belt is fastened and tensioned with the aid of timing belt tensioner

LINEAR AXIS LR 16 - 90X90

Part no.

28.0800/0

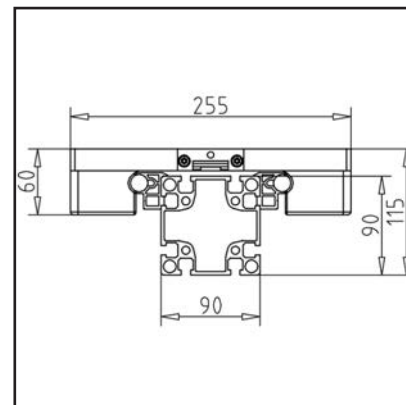
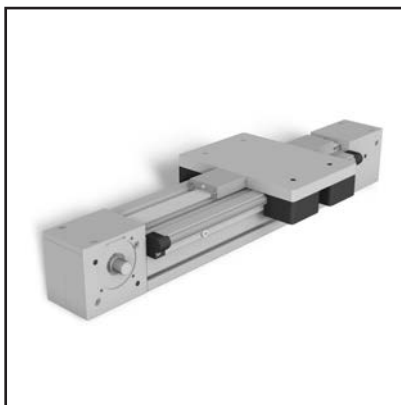
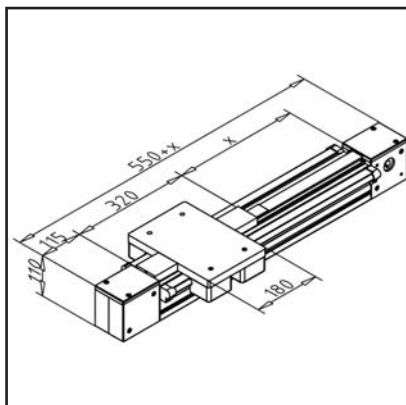
**TECHN. DATA / ITEMS SUPPLIED**

- Linear guide, ready for use, consisting of:
- 1x rail LR 16 - 90 with shaft fixation
- 2x timing belt pulley T90
- 2x timing belt tensioner
- 1x slide LR16-90
- 1x timing belt 32AT10
- **Please specify stroke length X and reverse unit**
- Weight = (basic weight) 14.45 kg
- Extra weight = 1.08 kg / 100 mm stroke

APPLICATIONS

- Handling devices
- Measuring devices
- Calibration devices

ASSEMBLY

- Belt is fastened and tensioned with the aid of timing belt tensioner

LINEAR AXIS LR 16 - 90X180

Part no. 28.0801/0

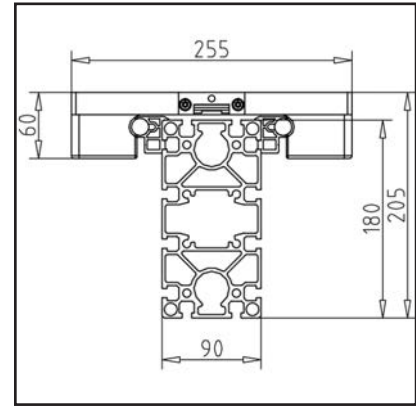
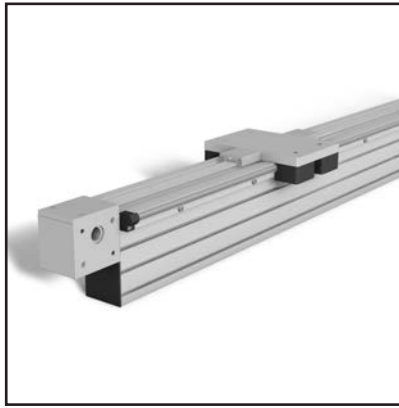
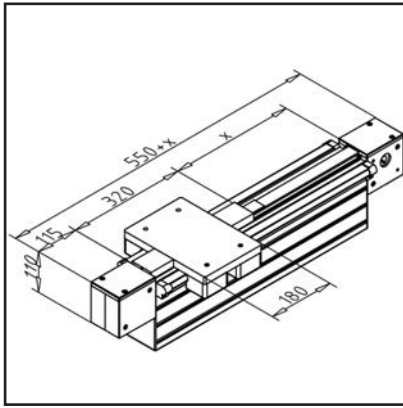

TECHN. DATA / ITEMS SUPPLIED

- Linear guide, ready for use, consisting of:
- 1x rail LR 16 - 90x180 with shaft fixation
- 2x timing belt pulley T90
- 2x timing belt tensioner
- 1x slide LR16-90
- 1x timing belt 32AT10
- **Please specify stroke length X and reverse unit**
- Weight = (basic weight) 17.51 kg
- Extra weight = 1.741 kg / 100 mm stroke

APPLICATIONS

- Handling devices
- Measuring devices
- Calibration devices

ASSEMBLY

- Belt is fastened and tensioned with the aid of timing belt tensioner

FASTENING KIT 90 S-S

Part no. 28.0264/0

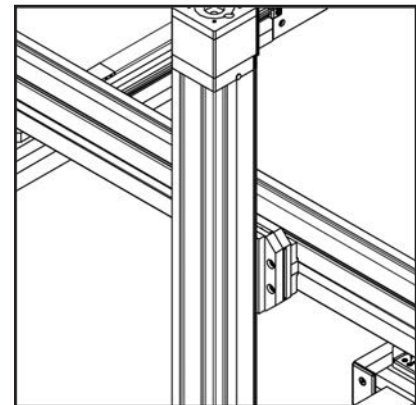
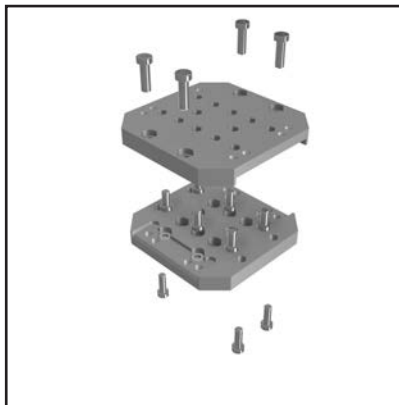
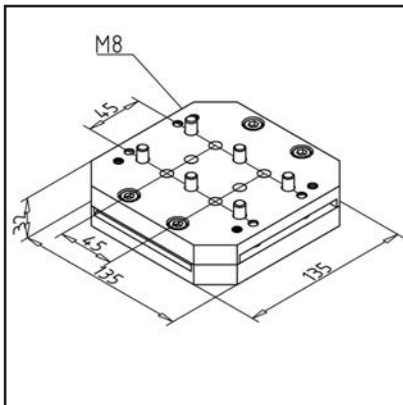

TECHN. DATA / ITEMS SUPPLIED

- Aluminium, anodized E6/EV1
- Adapter plate 90
- With fastening material steel, zinc plated
- Weight = 1.487 kg/piece

APPLICATIONS

- For connection of 2 axes under 90°

ASSEMBLY

- Both slide-mounted plates are connected:
 - LMS with LMS / LMZ or
 - LMZ with LMZ / LMS or
 - LR12 with LMS / LMZ

FASTENING KIT 90 S-A 90°

Part no.

28.0173/0

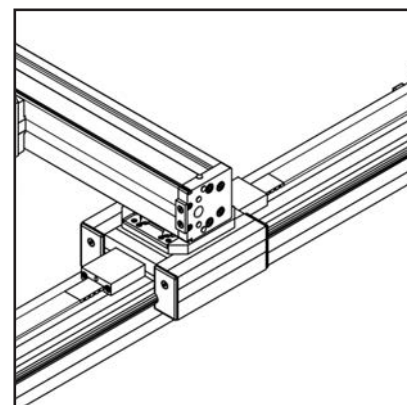
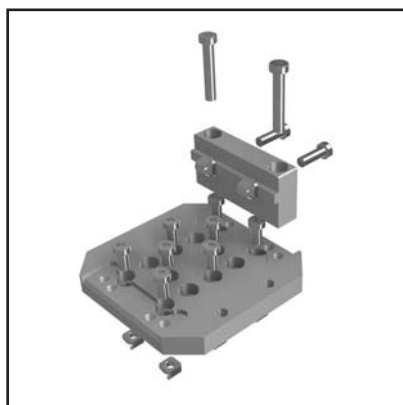
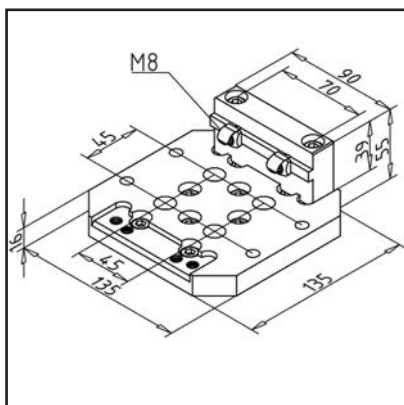
**TECHN. DATA / ITEMS SUPPLIED**

- Aluminium, anodized E6/EV1
- Adapter plate 90
- With fastening material steel, zinc plated
- Weight = 1.039 kg/piece

APPLICATIONS

- For connection of 2 axes under 90°

ASSEMBLY

- Large plate is mounted on slide of:
 - LR6 or
 - LR6 compact or
 - LMS or- LMZ or
 - LR12 z.B. LW 45 / LW 90 or
 - slide of adjusting units
- No plate is mounted on: Carrier profile of the cross-sectional axis

FASTENING KIT 90 S-A 180°

Part no.

28.0265/0

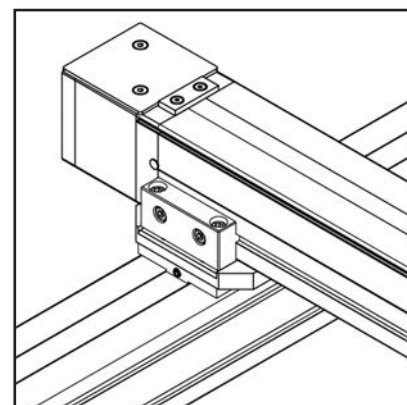
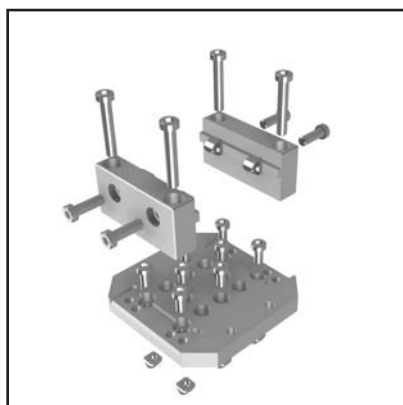
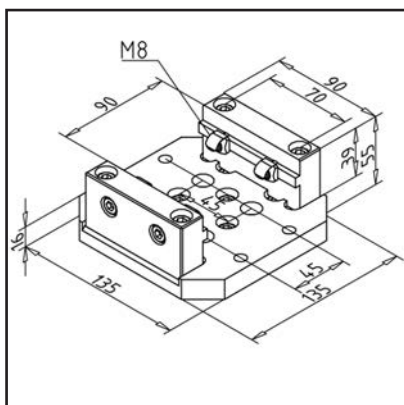
**TECHN. DATA / ITEMS SUPPLIED**

- Aluminium, anodized E6/EV1
- Adapter plate 90
- With fastening material steel, zinc plated
- Weight = 1.359 kg/piece

APPLICATIONS

- For connection of 2 axes under 90°

ASSEMBLY

- Large plate is mounted on slide of:
 - LR6 or
 - LR6 compact or
 - LMS or- LMZ or
 - LR12 z.B. LW 45 / LW 90 or
 - slide of adjusting units
- Small plates are mounted on: Carrier profile of the cross-sectional axis

FASTENING KIT 45 S-A 90°

Part no. 28.0174/0

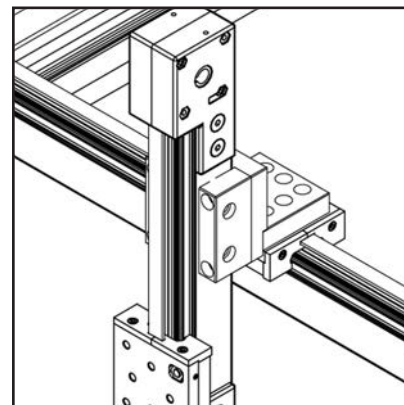
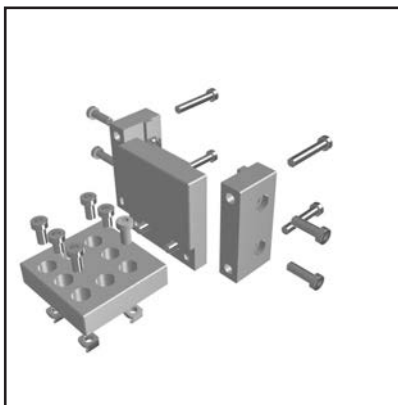
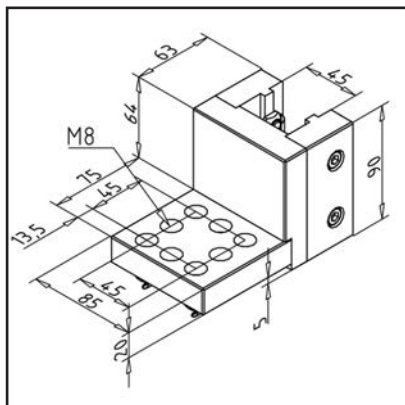

TECHN. DATA / ITEMS SUPPLIED

- Aluminium, anodized E6/EV1
- Adapter plate 90
- With fastening material steel, zinc plated
- Weight = 1.548 kg/piece

APPLICATIONS

- For connection of 2 axes under 90°

ASSEMBLY

- Large plate is mounted on slides of:
 - LR6 or
 - LR6 compact
- Small plates are mounted on: Carrier profile of the cross-sectional axis

FASTENING KIT 45 S-A 180°

Part no. 28.0175/0

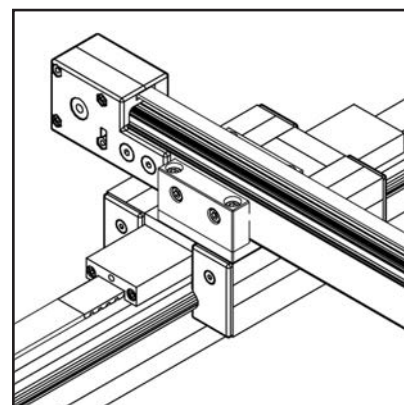
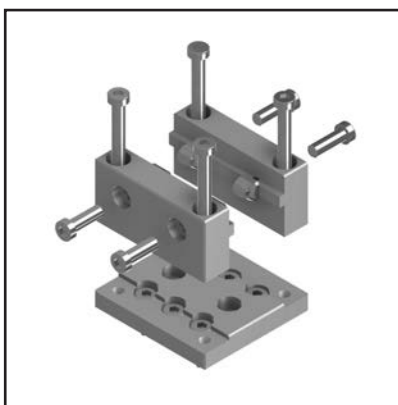
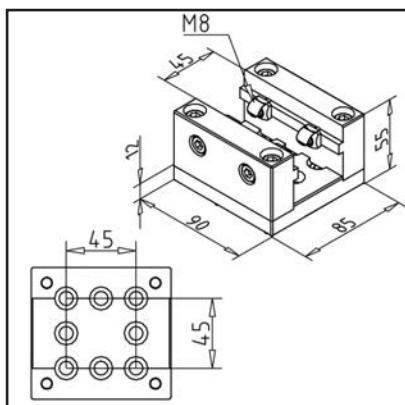

TECHN. DATA / ITEMS SUPPLIED

- Aluminium, anodized E6/EV1
- Adapter plate 90
- With fastening material steel, zinc plated
- Weight = 0.938 kg/piece

APPLICATIONS

- For connection of 2 axes under 90°

ASSEMBLY

- Large plate is mounted on slide of:
 - LR6 or
 - LR6 compact or
 - LMS or- LMZ or
 - LR12 z.B. LW 45 / LW 90 or
 - slide of adjusting units
- Small plates are mounted on: Carrier profile of the cross-sectional axis

BELLOW LR 45

Part no.

33.3007/0

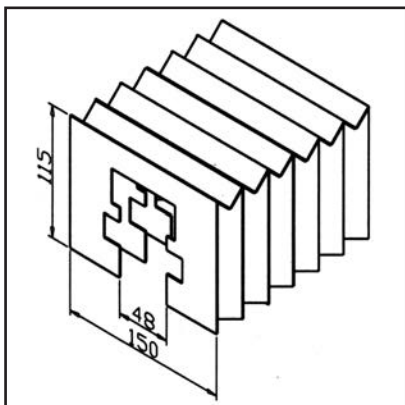
**TECHN. DATA / ITEMS SUPPLIED**

- Plastic, black with plastic frame
- Without fastening kit
- max. length 6 m
- Length when pushed together for 1 m travel:
 - 130 mm
- Temperature resistant(-30° to +90°C)
- Resistant to most acids and oils
- Weight = 0.650 kg/m

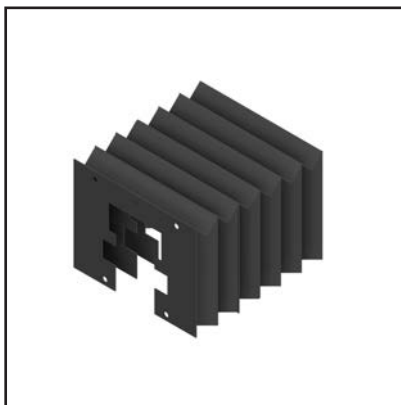
**APPLICATIONS**

- Cover of MiniTec linear guides LR 45
- Rough working conditions, dust, chips

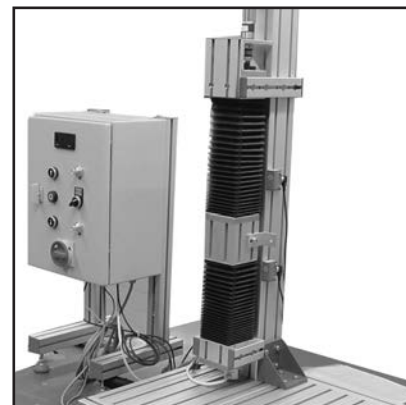
**ASSEMBLY**

- Push bellow onto rail
- Fasten to slide or pulley with fastening kit for bellow **part no. 33.3010/0**
- Bellow is supplied without perforation
- Due to the bellows, the usable travel distance is reduced by approx. 22%
- Caution: Consider higher friction moment when dimensioning drive unit!

FASTENING FOR BELLOW LR 45

Part no.

33.3010/0

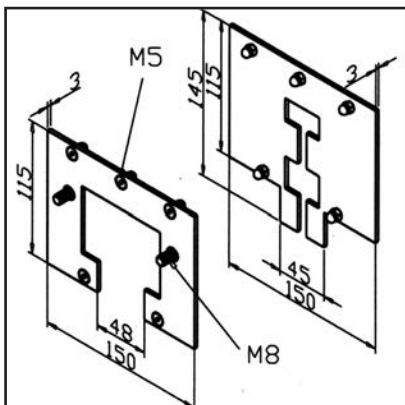
**TECHN. DATA / ITEMS SUPPLIED**

- Aluminium, anodized E6/EV1
- 1 End frame slide
- 1 End frame pulley
- Fastening kit for frame and bellow
- Weight = 0.275 kg/piece

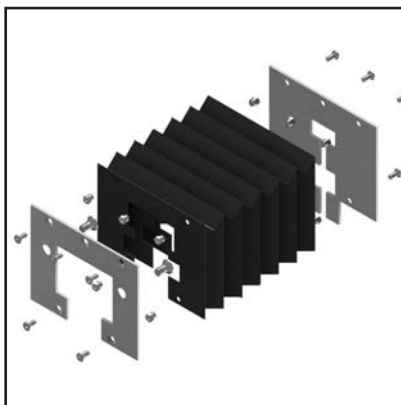
**APPLICATIONS**

- Fastening bellows LR 45 to carriages LW 45
- Fastening bellows LR 45 to timing belt reversing unit LW 45

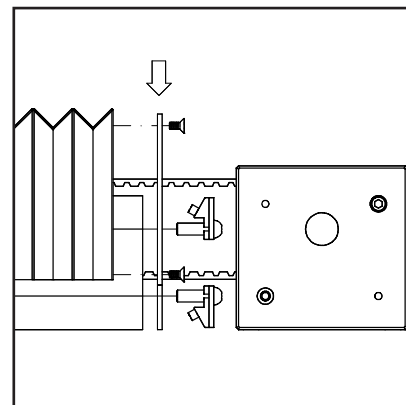
**ASSEMBLY**

- Fasten end frame on slide
- Push bellow onto rail
- Loosen power-lock fastener on the pulley side and insert end frame pulley between rail and timing belt pulley; tighten power-lock fastener
- Fasten protective bellow by means of the supplied screws on the end frame

BELLOW LR 90

Part no. 33.3008/0

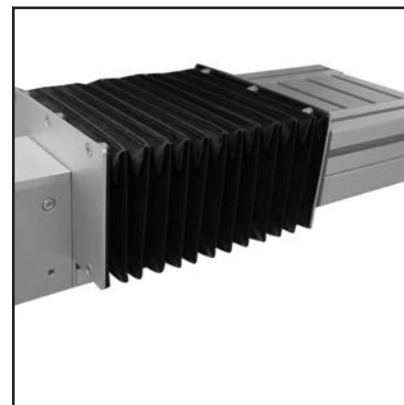
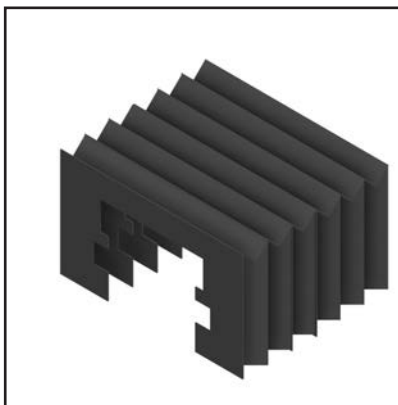
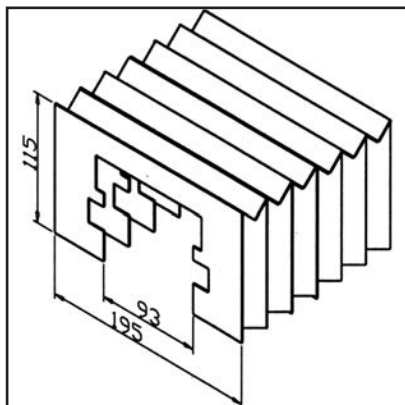

TECHN. DATA / ITEMS SUPPLIED

- Plastic, black with plastic frame
- Without fastening kit
- Length when pushed together for 1 m travel:
 - 130 mm
- max. length 6 m
- Temperature resistant (-30° to +90°C)
- Resistant to most acids and oils
- Weight = 0.750 kg/m

APPLICATIONS

- Cover of MiniTec linear guides LR 90
- Rough working conditions, dust, chips

ASSEMBLY

- Push bellow onto rail
- Fasten ends with attachment for bellows **part no. 33.3011/0** to carriages or reverse unit
- Bellow is supplied without perforation
- Due to the bellows, the usable travel distance is reduced by approx. 22%
- Caution: Consider higher friction moment when dimensioning drive unit!

FASTENING FOR BELLOW LR 90

Part no. 33.3011/0

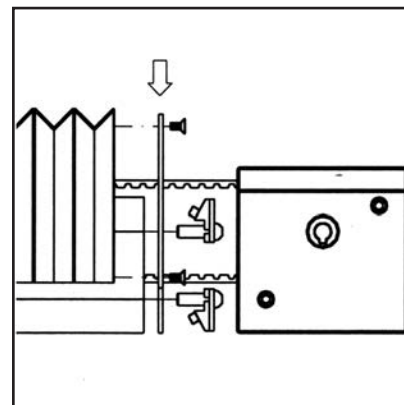
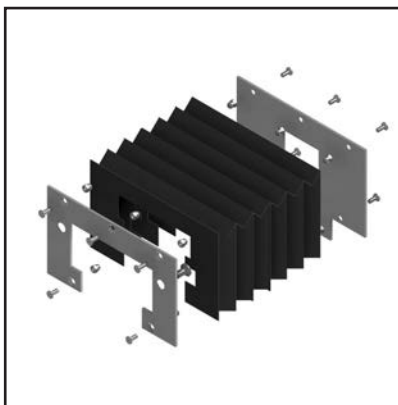
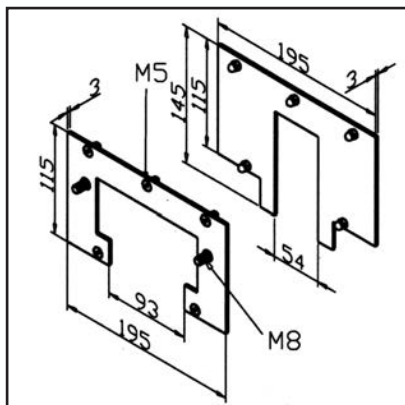

TECHN. DATA / ITEMS SUPPLIED

- Aluminium, anodized E6/EV1
- 1 End frame slide
- 1 End frame pulley
- Fastening kit for frame and bellow
- Weight = 0.750 kg/piece

APPLICATIONS

- Fastening bellows LR 90 to carriages LW 90
- Fastening bellows LR 90 to timing belt reversing unit LW 90

ASSEMBLY

- Fasten end frame on slide
- Push bellow onto rail
- Loosen power-lock fastener on the pulley side and insert end frame pulley between rail and timing belt pulley; tighten power-lock fastener
- Fasten protective bellow by means of the supplied screws on the end frame

BELLOW LR 180

Part no.

33.3009/0

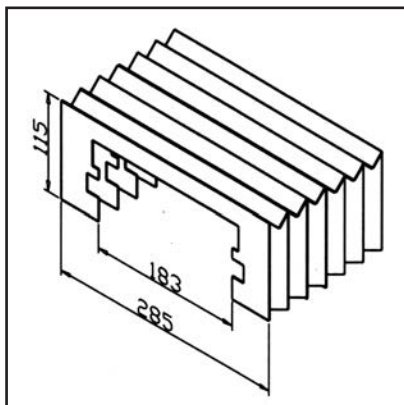
**TECHN. DATA / ITEMS SUPPLIED**

- Plastic, black with plastic frame
- Without fastening kit
- Length when pushed together for 1 m travel:
 - 130 mm
- max. length 6 m
- Temperature resistant (-30° to +90°C)
- Resistant to most acids and oils
- Weight = 0.950 kg/m

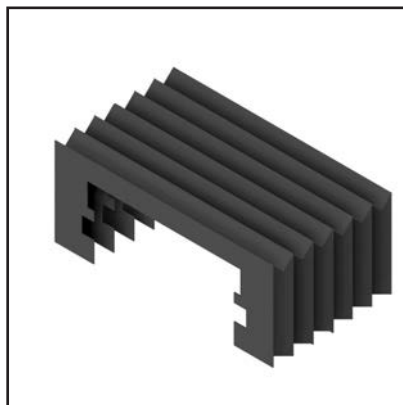
**APPLICATIONS**

- Cover of MiniTec linear guides LR 180
- Rough working conditions, dust, chips

**ASSEMBLY**

- Push bellow onto rail
- Fasten ends with attachment for bellows **part no. 33.3012/0** to carriage or reverse unit
- Bellow is supplied without perforation
- Due to the bellows, the usable travel distance is reduced by approx. 22%
- Caution: Consider higher friction moment when dimensioning drive unit!

FASTENING FOR BELLOW LR 180

Part no.

33.3012/0

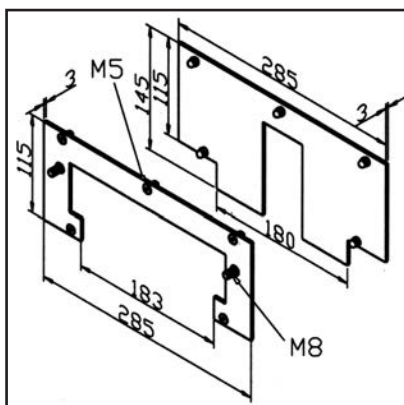
**TECHN. DATA / ITEMS SUPPLIED**

- Aluminium, anodized E6/EV1
- 1 End frame slide
- 1 End frame pulley
- Fastening kit for frame and bellow
- Weight = 0.463 kg/piece

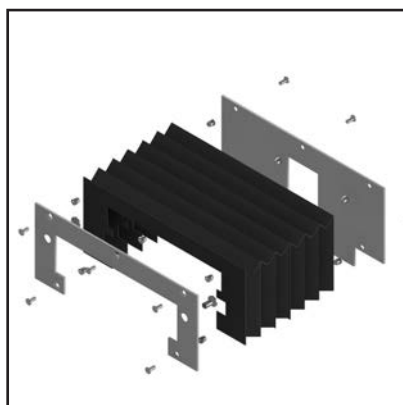
**APPLICATIONS**

- Fastening bellows LR 180 to carriages LW 180

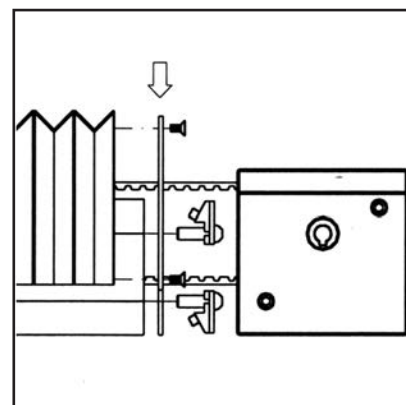
**ASSEMBLY**

- Fasten end frame on slide
- Push bellow onto rail
- Loosen power-lock fastener on the pulley side and insert end frame pulley between rail and timing belt pulley; tighten power-lock fastener
- Fasten protective bellow by means of the supplied screws on the end frame

CONNECTING SHAFT 45

Part no.

17.1706/0

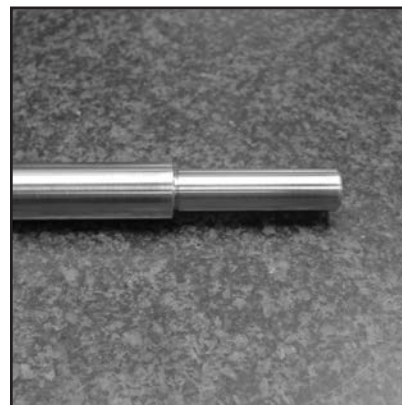
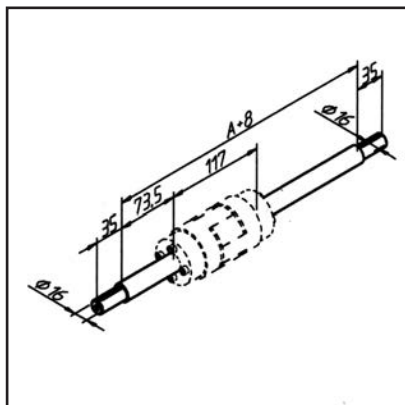

TECHN. DATA / ITEMS SUPPLIED

- Steel shaft \varnothing 20 mm
- 2 pieces, clutch not included
- With fastening material and feather key
- Length A = light distance between timing belt pulleys
- **Please indicate distance A**
- Other lengths and finishes available upon customer request
- Weight = 2,47 kg/m

APPLICATIONS

- Simultaneous transmission of 2 parallel linear guides
- Install support bearing for longer shafts

ASSEMBLY

- Push the shafts with the feather key and the pressure plate into the timing belt reverse unit and secure with the pressure plate and the countersunk screw included
- Connect both shaft pieces with clutch **part no. 28.0180/0**

CONNECTING SHAFT 90

Part no.

17.1706/1

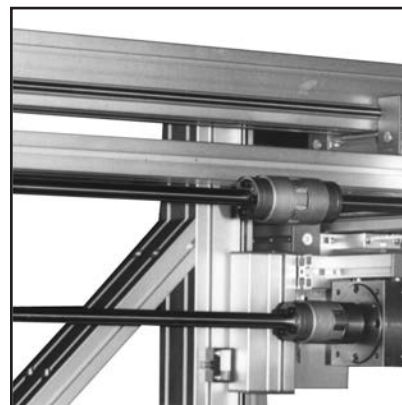
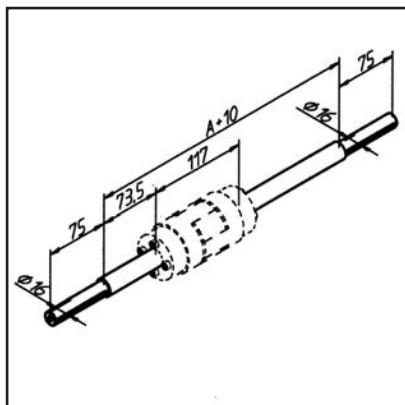

TECHN. DATA / ITEMS SUPPLIED

- Steel shaft \varnothing 20 mm
- 2 pieces, clutch not included
- With fastening material and feather key
- Length A = light distance between timing belt pulleys
- **Please indicate distance A**
- Other lengths and finishes available upon customer request
- Weight = 2,47 kg/m

APPLICATIONS

- Simultaneous transmission of 2 parallel linear guides
- Install support bearing for longer shafts

ASSEMBLY

- Push the shafts with the feather key and the pressure plate into the timing belt reverse unit and secure with the pressure plate and the countersunk screw included
- Connect both shaft pieces with clutch **part no. 28.0180/0**

CLUTCH 20

Part no.

28.0180/0

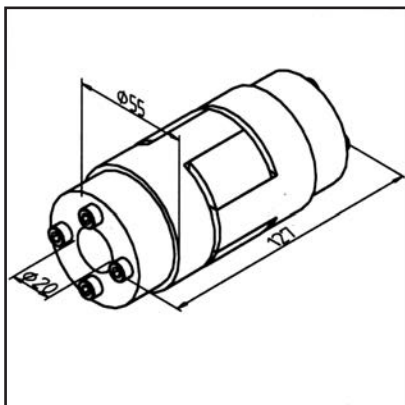
**TECHN. DATA / ITEMS SUPPLIED**

- Clutch, steel with plastic inlay
- 2 tensioning sets, steel
- max. torque 30Nm
- Weight = 0.984 kg/piece

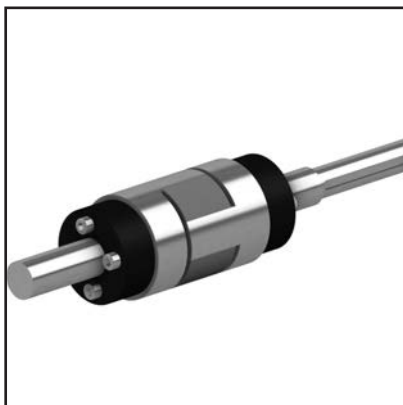
**APPLICATIONS**

- Connection of motors to reverse unit
- Misalignment compensation with simultaneous drive of 2 parallel linear axes with connection shaft 45 **part no. 17.1706/0** or 90 **part no. 17.1706/1**

**ASSEMBLY**

- Attachment with integrated tensioning device
- Adjust the axes synchronously and fasten clamping sets

TIMING BELT 16 AT 5

Part no.

28.0502/0

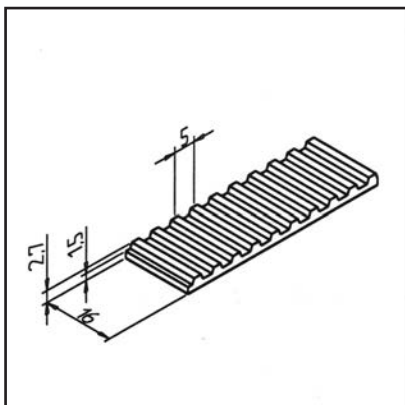
**TECHN. DATA / ITEMS SUPPLIED**

- PUR white, steel-wire reinforced
- Type 16 AT 5
- load capacity up to 1260 N
- Weight = 0.053 kg/m

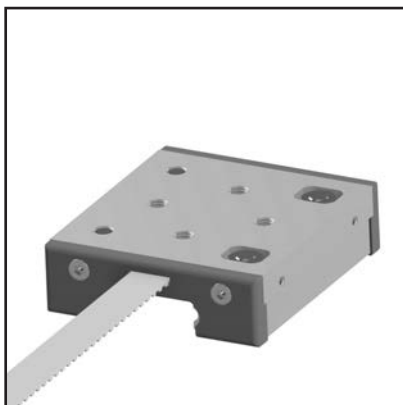
**APPLICATIONS**

- For MiniTec linear guides LR 6 Z

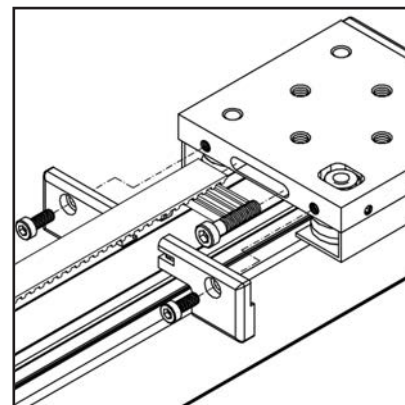
**ASSEMBLY**

- Insert timing belt of corresponding length into the carriage LR 6 Z
- Length determination: 2x rail length + 260 mm

TIMING BELT 32 AT 10

Part no. 28.0093/0

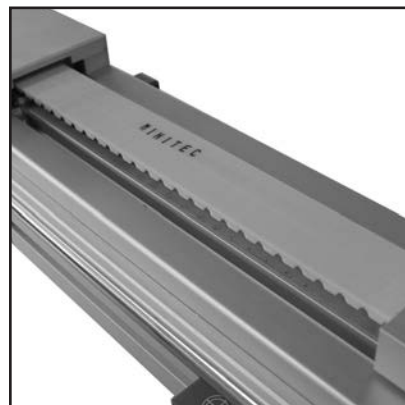
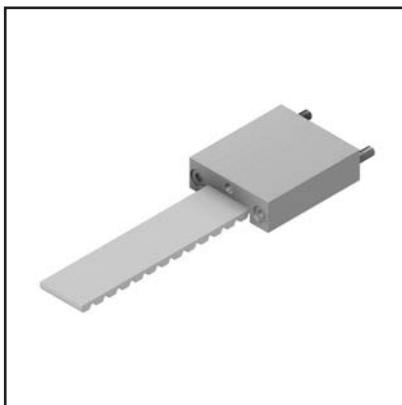
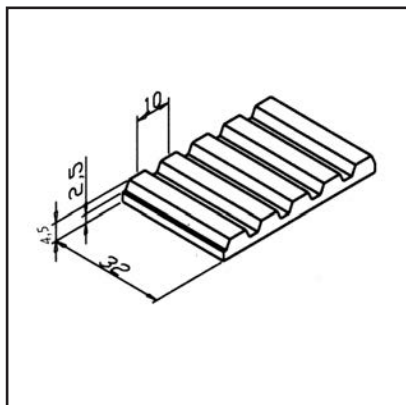

TECHN. DATA / ITEMS SUPPLIED

- PUR white, steel-wire reinforced
- Type 32 AT 10
- load capacity up to 4750 N
- Weight = 0.190 kg/m

APPLICATIONS

- For MiniTec-Linear guides LR 12 and LR 16
- Belt conveyors

ASSEMBLY

- Attach the timing belt in the appropriate length to the belt tensioner

TIMING BELT TENSIONER

Part no. 28.0090/0

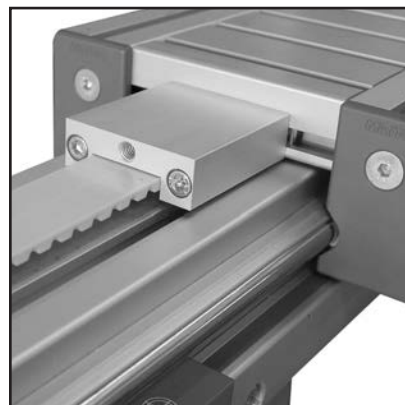
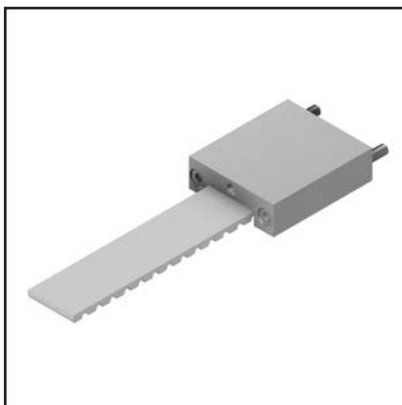
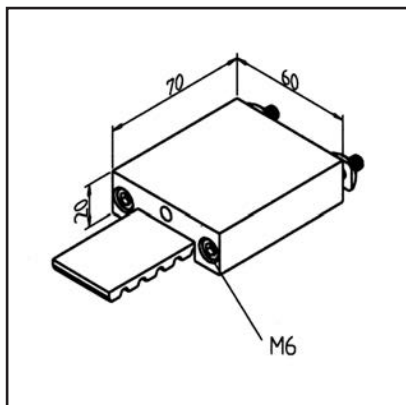

TECHN. DATA / ITEMS SUPPLIED

- Aluminium, anodized E6/EV1
- With fastening material steel, zinc plated
- Housing Aluminum natural anodized
- Tension slide steel, galvanized, with inserted counterpart with 3 teeth
- For timing belt 32 AT 10
- Stainless version **part no. 28.0090/1**
- Weight = 0.244 kg/piece

APPLICATIONS

- For MiniTec-Linear guides LR 12 and LR 16
- For MiniTec belt drive

ASSEMBLY

- Screw tight on the front of the carriage with supplied hardware
- After fixing on slide face, tension the belt central tensioning screw M8, 5 A/F
- Recommended voltage: according to design
- 1 timing belt tensioner requested per belt end

TIMING BELT TENSIONER REINFORCED TO CARRIAGE LW90

Part no.

28.0386/0

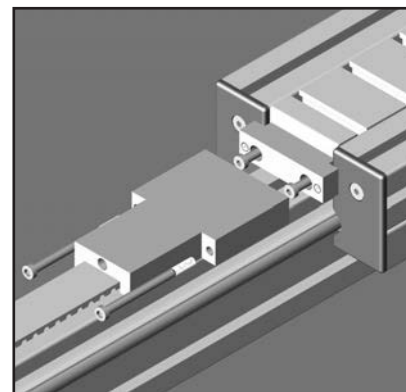
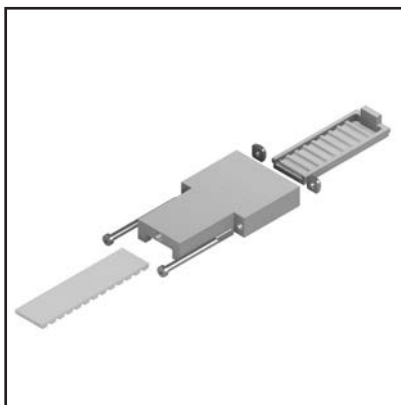
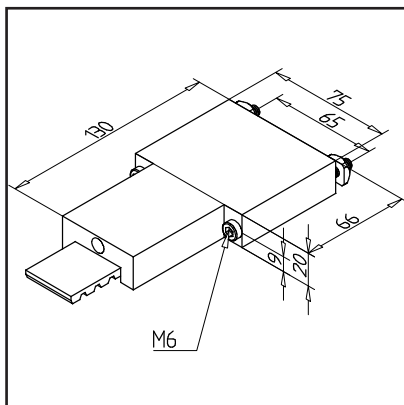

TECHN. DATA / ITEMS SUPPLIED

- Aluminium, anodized E6/EV1
- With fastening material steel, zinc plated
- Cocking slide steel, galvanized, with inlaid counterpart with 9 teeth
- For attachment to carriage LW 45 please use the timing belt tensioner with adapter **part no. 28.0386/1**
- Weight = 0.473 kg/piece

APPLICATIONS

- For linear axes with higher safety requirements
- For vertically arranged axles (lifting axles) it is usually sufficient to use the upper timing belt tensioner in reinforced version

ASSEMBLY

- Screw tight on the front of the carriage with supplied hardware
- After fixing on slide face, tension the belt central tensioning screw M8, 5 A/F
- Recommended voltage: according to design

TOOTHED RACK 8

Part no.

28.0051/0

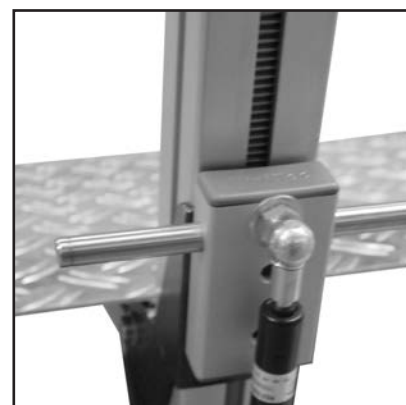
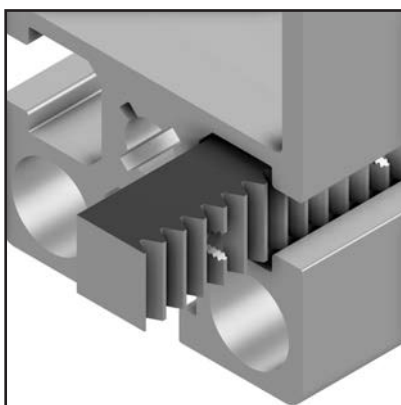
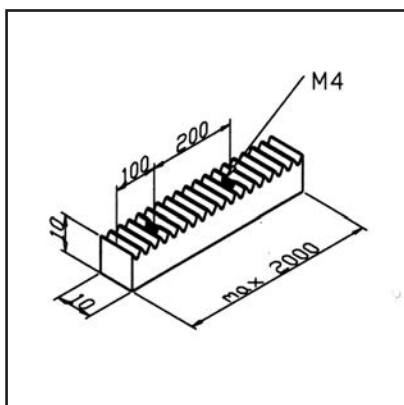

TECHN. DATA / ITEMS SUPPLIED

- Steel, bright
- Modul 1
- Weight = 0,785 kg/m
- Bar length = 2 m

APPLICATIONS

- Linear guides with very long travels
- Linear guides for short building room
- Repeated height and length settings in grid 3.14 mm (for ex. sorting frame)

ASSEMBLY

- Insert timing rack into profile groove
- Secure with setscrew from delivery scope - Grid 200 mm

CONNECTION OF MOTORS

Timing belt pulley LR 6 & LR 6 compact

Three-phase, stepper or servo motors with drive pins up to a maximum \varnothing 14 mm are fastened directly to the deflection. The bore of the pulley with keyway and the adapter plate are also made to customer specification.

Timing belt pulley T 45

Three-phase, stepper or servo motors with drive pins up to a maximum \varnothing 16 mm are fastened directly to the deflection. The bore of the pulley with keyway and the adapter plate are also made to customer specification.

Timing belt pulley T 90

Three-phase, stepper or servo motors with drive pins up to a maximum \varnothing 24 mm are fastened directly to the deflection. The bore of the pulley with keyway and the adapter plate are also made to customer specification.

Determination of the timing belt length**When using T45 and T90**

$2 \times \text{rail length} + 2 \times 210 \text{ mm (redirection)}$
 $- \text{Carriage length} - 2 \times 20 \text{ mm (timing belt tensioner)}$
 $= 2 \times \text{rail length} - \text{carriage length} + 380 \text{ mm}$

When using LR6

$2 \times \text{rail length} + 260 \text{ mm}$

When using LR6 compact (timing belt 16 AT 5)

$2 \times \text{rail length} + 220 \text{ mm}$

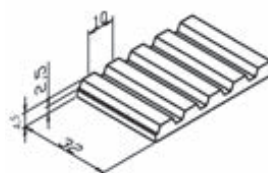

Timing belt 32 AT 10
Part no. 28.0093/0

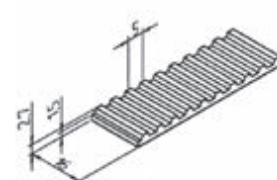

Timing belt 16 AT 5
Part no. 28.0502/0

Specifications of the pulleys in the timing belt deflecti

Timing belt-redirection	LR 6	T 45 (LR 12 & LR 16)	T 90 (LR 12 & LR 16)
Effective diameter	57,3 mm	60,48 mm	60,48 mm
Width of timing belt	16 mm	32 mm	32 mm
Number of teeth	36	19	19
Drill hole for drive shaft	10 mm	8 mm	8 mm
rillable to max.	14 mm	16 mm	30 mm
Travel distance (1 turn)	180 mm	190 mm	190 mm
TIMING BELT	16AT5	32AT10	32AT10
Belt length in deflection	160 mm	210 mm	210 mm
Maximum torque	30 Nm	70 Nm	130 Nm

COMPONENTS – LINEAR SYSTEM LR

This system is based on double-row profiled rollers made of ball bearing steel and hardened precision shafts made of material 1.1213 (CF 53). Guides of any length can be produced with this system. The carriages are equipped with 2-row profiled rollers whose shaft raceway is designed as a Gothic arch. For very high loads, the trolleys can be equipped with any number of track rollers. The profiled rollers are fastened directly to the carriage plate with steel strips. No special roller profiles are required for the construction of the trolleys. This gives the construction maximum rigidity. The backlash-free adjustment of the guides is carried out with eccentric bushes.

The carriages are completely encapsulated, scraper felts are integrated into the cover caps, which simultaneously remove coarse dirt from the shafts and supply them with lubricant. The felts can be replaced quickly and easily after loosening the lateral screw connection. This advantage has an extremely positive effect, especially in dirty or rough operating conditions. Both closed and open-frame trolleys in any length and width are possible. Please indicate the desired dimensions A and B

when ordering.

(see special versions on page XXX above).

X/Y tables can be produced simply by attaching 4 castors to the top of the trolley. In this configuration, the running rail of the Y-axis is made of profile 45 x 32. Cover caps LR and cover profile LR fit for the Y-axis.

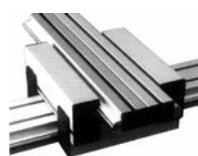

X/Y-Table

LR 6 Z compact

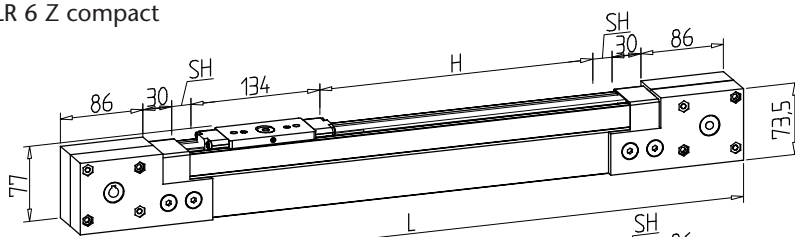

LR 6 Z compact

Calculation of the total length L:

Required traverse H
 + Car length (134)
 + 2 x Timing belt pulley (172)
 + 2 x Trap guard (60)
 = Traverse + 366 mm *

LR 6

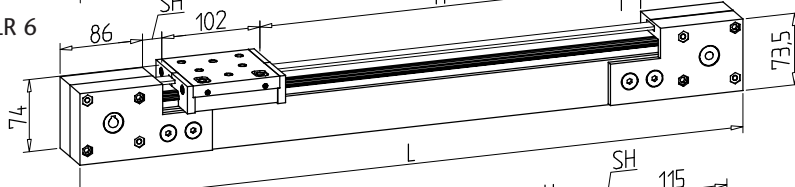

LR 6

Calculation of the total length L:

Required traverse H
 + Car length (102)
 + 2 x Timing belt pulley (172)
 = Traverse + 274 mm*

LR 12

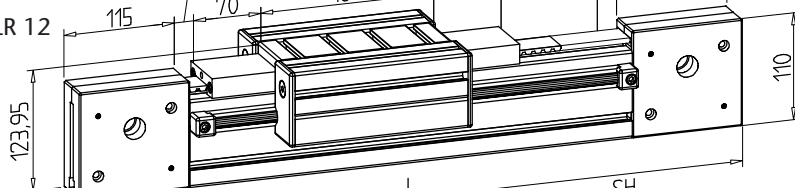

LR 12 + LR 16

Calculation of the total length L:

Required traverse H
 + Car length (180)
 + 2 x Timing belt pulley (230)
 + 2 x Timing belt tensioner (140)
 = Traverse + 550 mm

LR 16

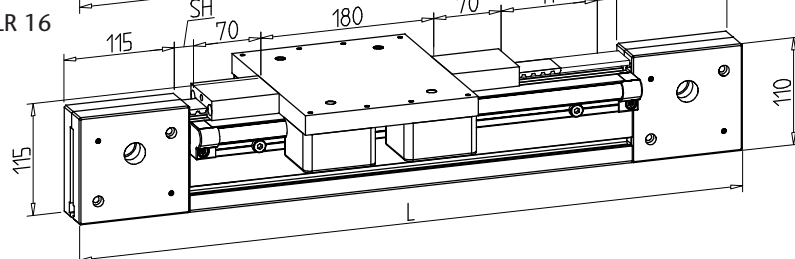

*Since the belt tension is applied via the timing belt deflection, this is only an indication!

Safety distances „SH“ if necessary, additionally calculate and specify!

RAILS



LR 6 compact
Part no. 28.0119/0



LR 6 S
Part no. 28.0525/0



LR 12
Rail 19
Part no. 28.0009/0

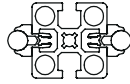

LR 12
Rail 32
Part no. 28.0010/0

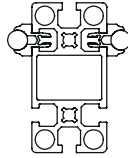

LR 12
Rail 45
Part no. 28.0006/0

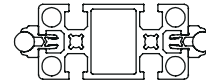

LR 12
Rail 45 x 90 H
Part no. 28.0007/2

LR 12
Rail 45 x 90 F
Part no. 28.0007/1

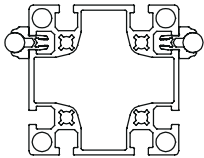

LR 12
Rail 90
Part no. 28.0008/0

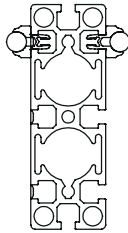

LR 12
Rail 135 H
Part no. 28.0012/2

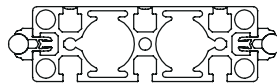

LR 12
Rail 135 F
Part no. 28.0012/1

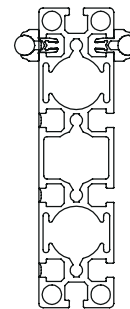

LR 12
Rail 45 x 180 H
Part no. 28.0013/2

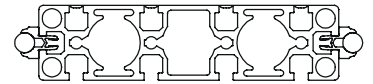

LR 12
Rail 45 x 180 F
Part no. 28.0013/1

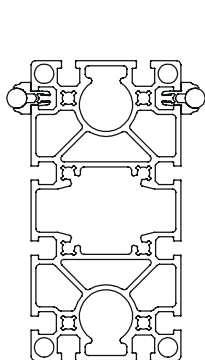

LR 12
Rail 180 H
Part no. 28.0011/2

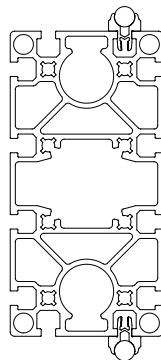

LR 12
Rail 180 F
Part no. 28.0011/1

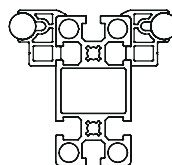

LR 16
Rail LR16 - 45 x 90H
Part no. 28.0820/0

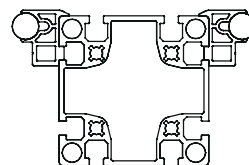

LR 16
Rail LR16 - 90
Part no. 28.0821/0

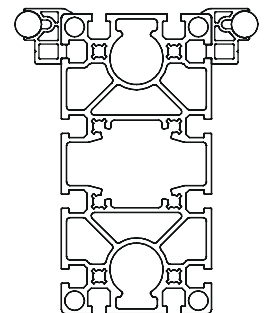

LR 16
Rail LR16 - 90 x 180H
Part no. 28.0822/0

RAILS



LR 6 compact and LR 6 S - further combination possibilities:

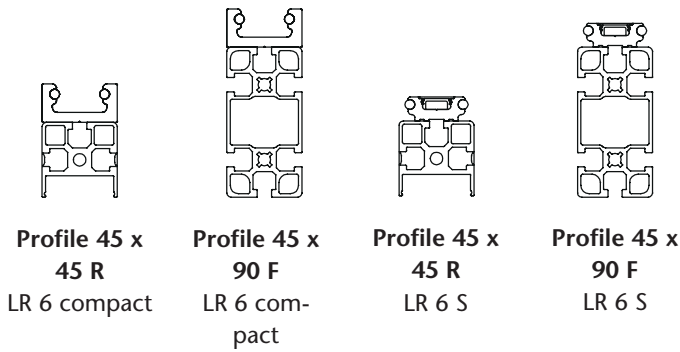

LR 12 - further combination possibilities:

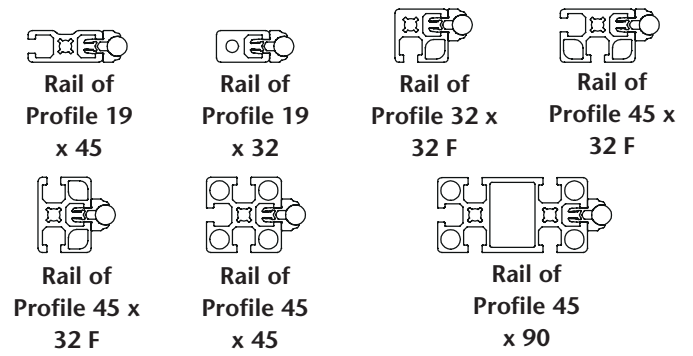

LR 12 - further combination possibilities:

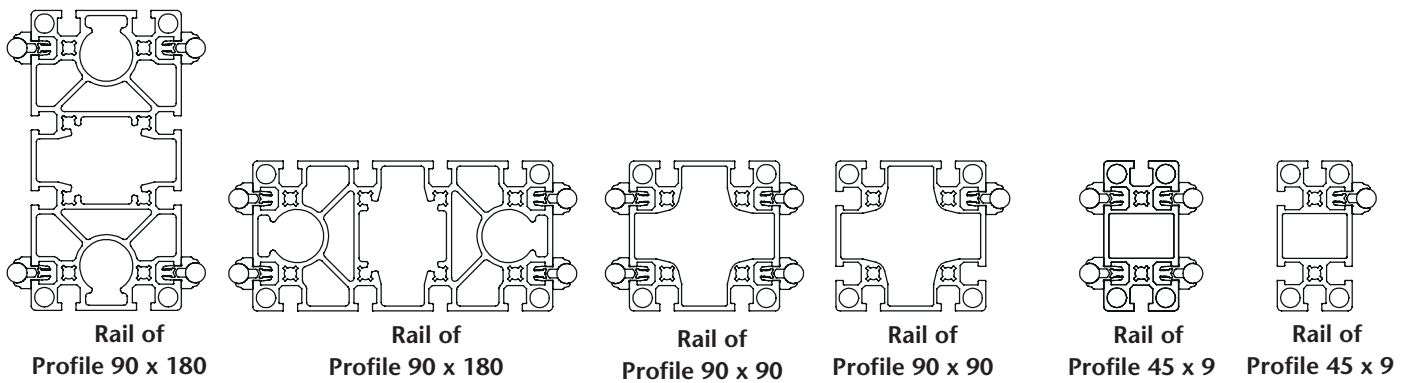

CARRIAGE MODELS

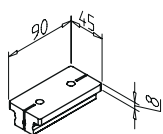

Sliding carriage
LR 6 compact
Part no. 28.0127/0

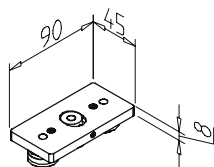

LR 6 compact
Part no. 28.0140/0

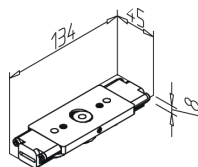

LR 6 Z compact
Part no. 28.0520/0

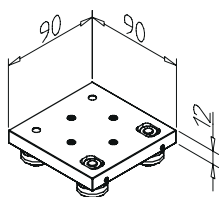

LR 6
Part no. 28.0138/0

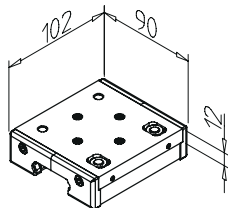

LR 6 with cover
Part no. 28.0138/1

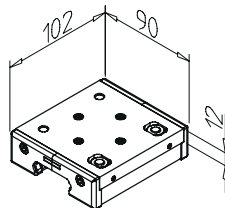

LR 6 Z
Part no. 28.0138/2

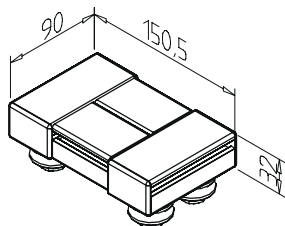

LW 32
Part no. 28.0088/0

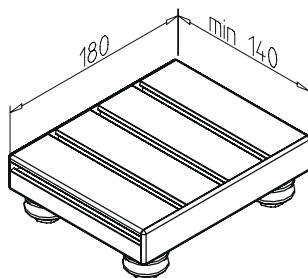

LW 32 E
Part no. 28.0089/0

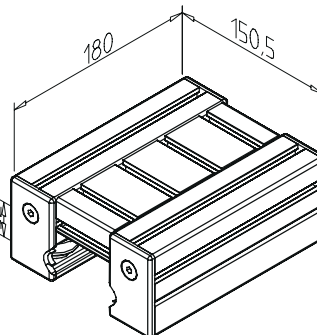

LW 45
Part no. 28.0091/0

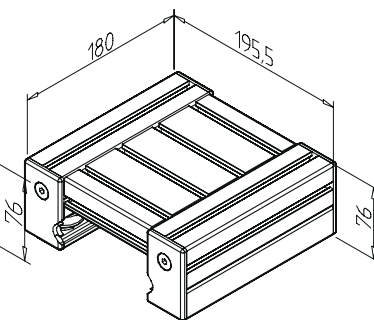

LW 90
Part no. 28.0092/0

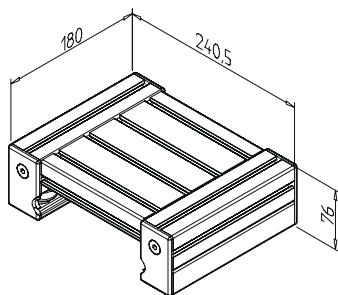

LW 135
Part no. 28.0084/0

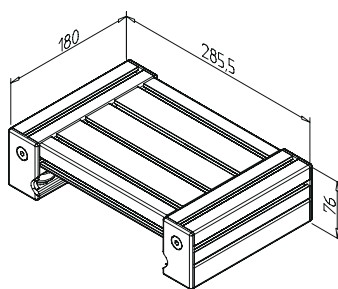

LW 180
Part no. 28.0087/0

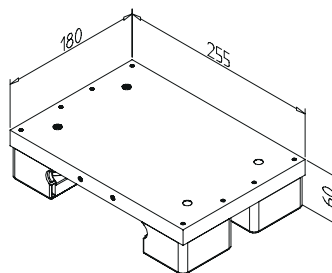

LR 16 - 90
Part no. 28.0811/0

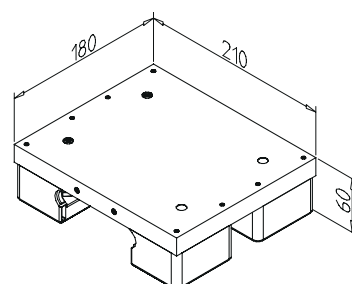

LR 16 - 45
Part no. 28.0810/0

CARRIAGE MODELS

Carriage special versions

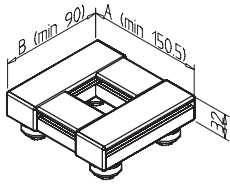

LW 32 Special version
(Open Frame)
Part no. 28.0089/2

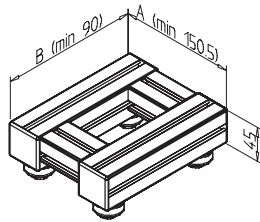

LW 45 Special version
(Open Frame)
Part no. 28.0091/4

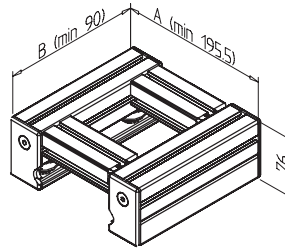

LW 90 Special version
(Open Frame)
Part no. 28.0092/3

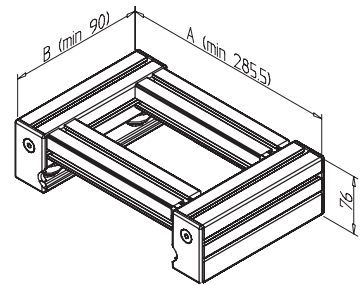

LW 180 Special version
(Open Frame)
Part no. 28.0087/2



CARRIAGE MODELS

COMBINATION POSSIBILITIES CARRIAGES AND RAILS

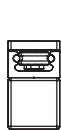

LW LR 6 compact
Rail LR 6 compact



LW LR 6 compact
Rail made of profile
45x90F

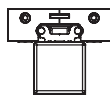

Carriage LR 6
Rail LR 6 S/45

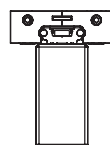

Carriage LR 6
Rail LR 6 S/90



Carriage LW 135
2x Special rail made of
profile 45 x 45

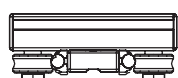

LW 32 E
Rail 19

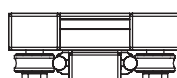

LW 32
Rail 32

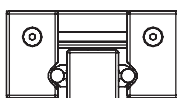

LW 45
Rail 45

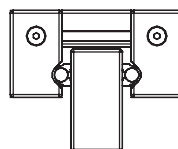

LW 45
Rail 45 x 90H

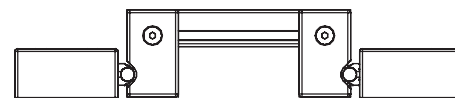

Special carriages
2x Special rail made of profile 45x90



LW 90
Rail 45 x 90 F

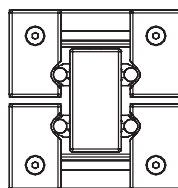

2x LW 45
Special rail made of
profile 45 x 90

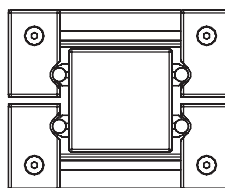

2x LW 90
Special rail made of
profile 90 x 90 L

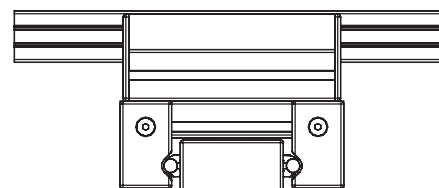

2x LW 90
Rail 45 x 90 F

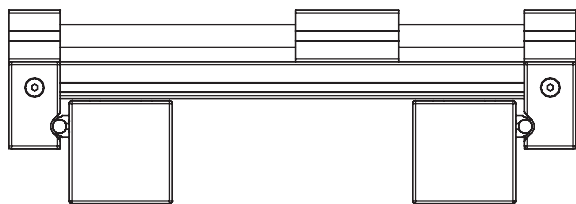

Special carriage
2x Special rail made of profile 90 x 90 L

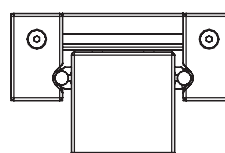

LW 90
Rail 90

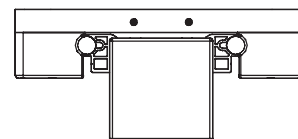

LR 16-90
Rail LR 16 - 90

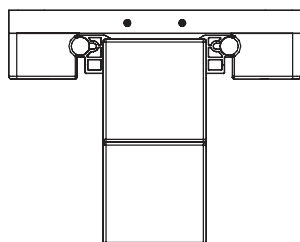

LR 16 - 90
Rail LR 16 - 90 x 180H

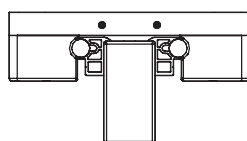

LR 16 - 45
Rail LR 16 - 45

PERMITTED LOADS

Linear-system	LR 6			LR 12				LR 16	
Car	LR 6 COMPACT	Car LR 6 with 4 Bearing L = 90 mm	Car 45 with 4 Bearing L = 180 mm	Car 90 with 4 Bearing L = 180 mm	Car 135 with 4 Bearing L = 180 mm	Car 180 with 4 Bearing L = 180 mm	Car 180 with 8 Bearing L = 360 mm	Car LR 16-45	Car LR 16-90
Mx max.	40 Nm	30 Nm	79 Nm	107 Nm	130 Nm	165 Nm	240 Nm	158 Nm	214 Nm
My max.	40 Nm	75 Nm	120 Nm	120 Nm	120 Nm	120 Nm	275 Nm	288 Nm	288 Nm
Mz max.	40 Nm	40 Nm	202 Nm	202 Nm	202 Nm	202 Nm	470 Nm	323 Nm	323 Nm
Fy max.	700 N	800 N	3500 N	3500 N	3500 N	3500 N	7000 N	7000 N	7000 N
Fz max.	1100 N	640 N	1500 N	1500 N	1500 N	1500 N	3000 N	3000 N	3000 N

Maximum traverse

Car 45 - 180: 10 m/sec

Car LR 6: 5 m/sec

Calculation of the permissible moment load depending on the car length, at 4 Bearing:

$$My \text{ max.} = 0,89 \times (L-45) \text{ Nm}$$

$$Mz \text{ max.} = 1,50 \times (L-45) \text{ Nm}$$

L = Car length

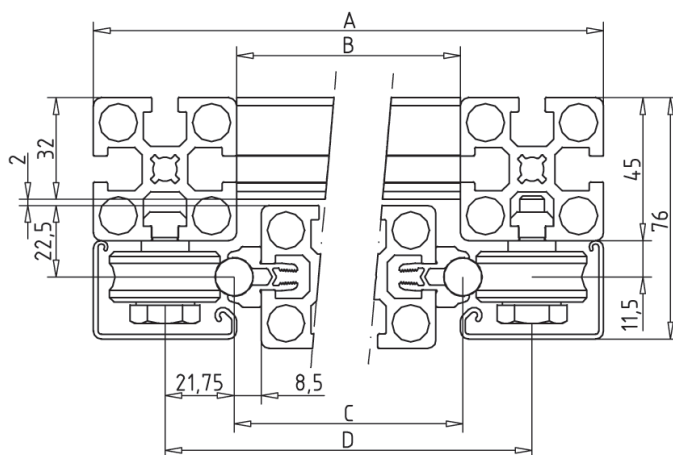
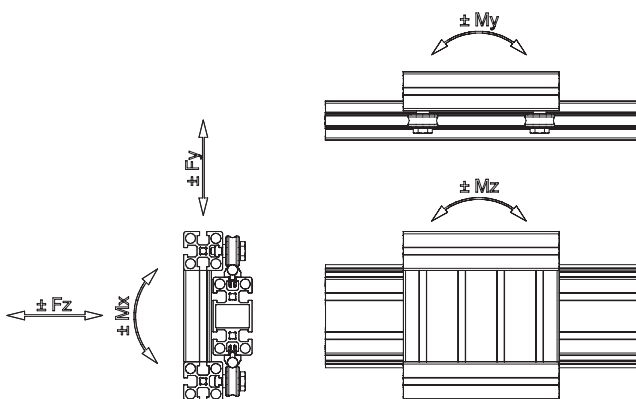

Command variable

Car type	LR 6 compact	LR 6	LW 45	LW 90	LW 135	LW 180	LR 16-45	LR 16-90
MEASURE								
A	45	90	150,5	195,5	240,5	285,5	210	255
B	-	-	60,5	105,5	150,5	195,5	-	-
C	30	32	62	107	152	197	85	130
D	2	60	105,5	150,5	195,5	240,5	149,5	194,5

RAIL LR 6 COMPACT

Part no.

28.0119/0

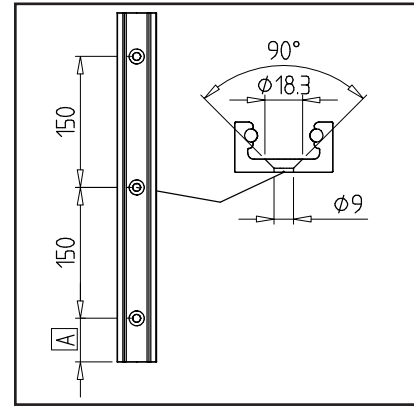
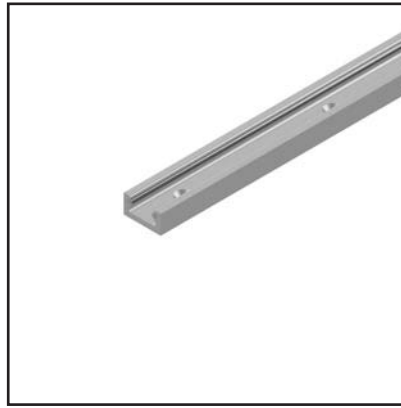
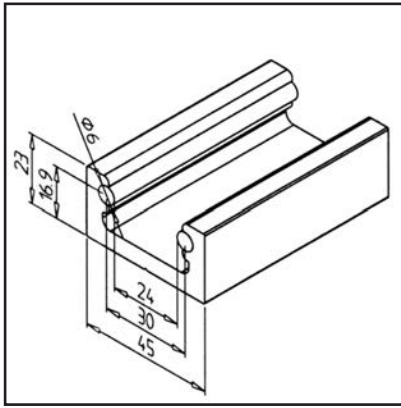

TECHN. DATA / ITEMS SUPPLIED

- Aluminium, anodized E6/EV1
- 2 shafts \varnothing 6 h6 steel
- Drilled ready for assembly \varnothing 8 mm, Division 150 mm
- Stainless version **part no. 28.0149/0**
- Weight = 1.781 kg/m
- Bar length = 6 m

APPLICATIONS

- Handling devices
- Guide large drawers
- Doors

ASSEMBLY

- Fasten the rail with the countersunk screw M8 x 20 and the square nut M8 to the MiniTec profile
- The hole pattern is cut to size centrally. If a different edge distance is required, please specify dimension A.
- Additional hole spacing is also possible.

RAIL LR 6 S

Part no.

28.0525/0

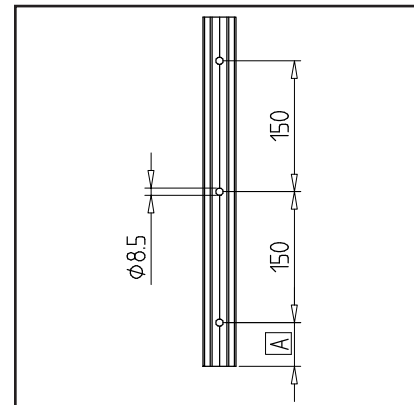
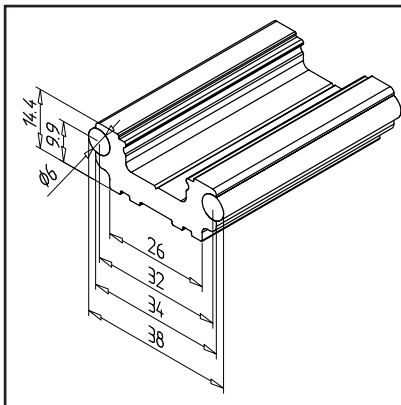

TECHN. DATA / ITEMS SUPPLIED

- Aluminium, anodized E6/EV1
- 2 shafts \varnothing 6 h6 steel
- Drilled ready for assembly \varnothing 8 mm, Division 150 mm
- Stainless version **part no. 28.0526/0**
- Weight = 0.959 kg/m
- Bar length = 6 m

APPLICATIONS

- MiniTec linear guide systems LR 6
- Handling devices
- Guide large drawers
- Doors

ASSEMBLY

- Fasten the rail with the countersunk screw M8 x 20 and the square nut M8 to the MiniTec profile
- Optional cover profile, **part no. 22.1160/0**
- The hole pattern is cut to size centrally. If a different edge distance is required, please specify dimension A.
- Additional hole spacing is also possible.

RAIL 19

Part no.

28.0009/0

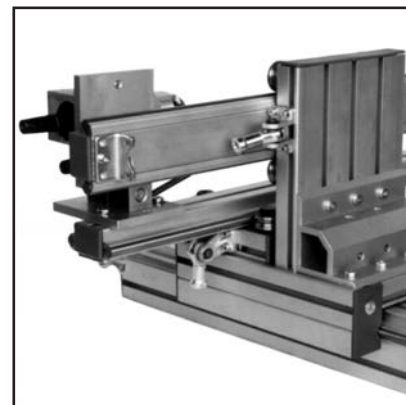
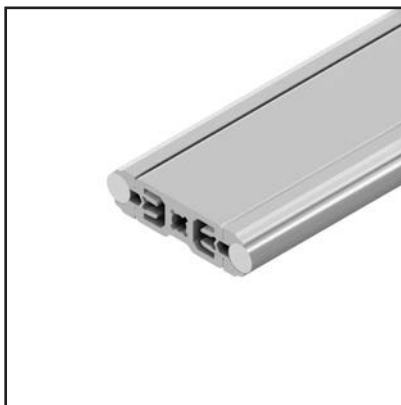
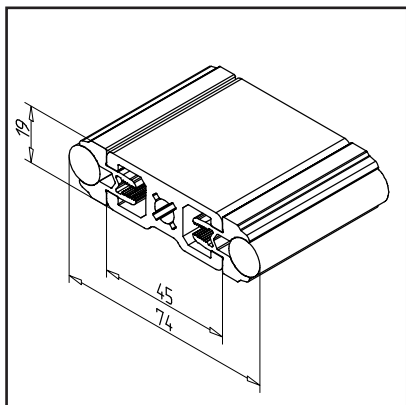
**TECHN. DATA / ITEMS SUPPLIED**

- Aluminium, anodized E6/EV1
- Profile 19 x 45
- On both sides with shaft supporting profile and shafts $\varnothing 12$ h6, pre-finished installed
- Without end caps
- Stainless version **part no. 28.0009/3**
- Weight = 3,666 kg/m
- Bar length = 6 m

APPLICATIONS

- Linear and column guides
- Longer rails with composite shafts possible

ASSEMBLY

- For vertical use or for high speed applications, we recommend the use of shaft retention devices **part no. 28.0052/0**
- To use shaft locking devices on both sides, the shaft and shaft carrier should be at least 30 mm shorter than the total length.

RAIL 32

Part no.

28.0010/0

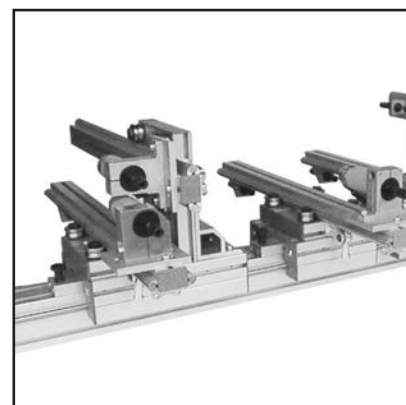
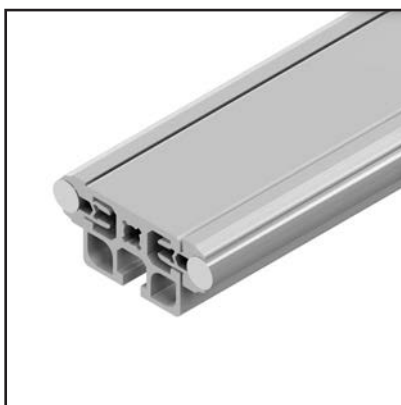
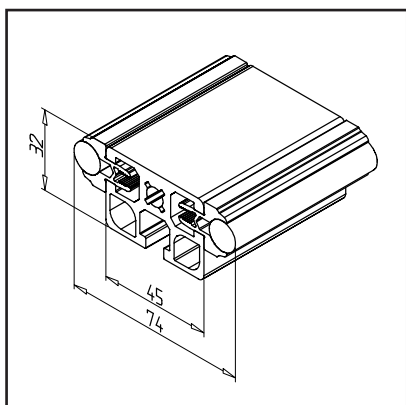
**TECHN. DATA / ITEMS SUPPLIED**

- Aluminium, anodized E6/EV1
- Profile 45 x 32 F
- On both sides with shaft supporting profile and shafts $\varnothing 12$ h6, pre-finished installed
- Without end caps
- Stainless version **part no. 28.0010/3**
- Weight = 4,161 kg/m
- Bar length = 6 m

APPLICATIONS

- Linear and column guides
- Longer rails with composite shafts possible

ASSEMBLY

- For vertical use or for high speed applications, we recommend the use of shaft retention devices **part no. 28.0052/0**
- To use shaft locking devices on both sides, the shaft and shaft carrier should be at least 30 mm shorter than the total length.

RAIL 45

Part no.

28.0006/0

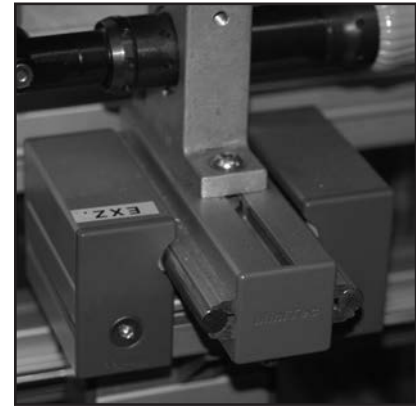
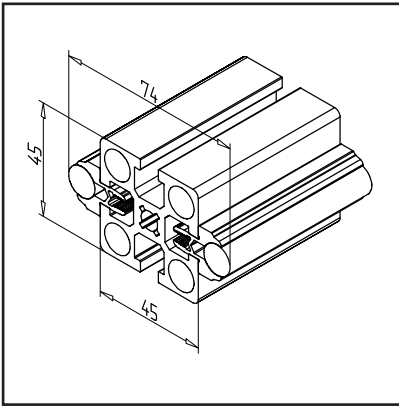

TECHN. DATA / ITEMS SUPPLIED

- Aluminium, anodized E6/EV1
- On both sides with shaft supporting profile and shafts $\varnothing 12$ h6, pre-finished installed
- Without end caps
- Stainless version **part no. 28.0006/3**
- Weight = 4,796 kg/m
- Bar length = 6 m

APPLICATIONS

- Linear and column guides
- Longer rails with composite shafts possible

ASSEMBLY

- For vertical use or for high speed applications, we recommend the use of shaft retention devices **part no. 28.0052/0**
- To use shaft locking devices on both sides, the shaft and shaft carrier should be at least 30 mm shorter than the total length.

RAIL 45X90 F

Part no.

28.0007/1

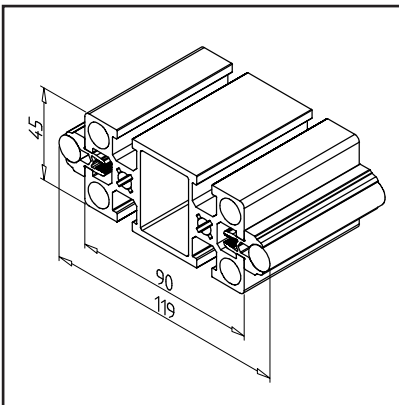

TECHN. DATA / ITEMS SUPPLIED

- Aluminium, anodized E6/EV1
- Profile 45 x 90
- On both sides with shaft supporting profile and shafts $\varnothing 12$ h6, pre-finished installed
- Without end caps
- Stainless version **part no. 28.0007/3**
- Weight = 6,190 kg/m
- Bar length = 6 m

APPLICATIONS

- Linear and column guides
- Longer rails with composite shafts possible

ASSEMBLY

- For vertical use or for high speed applications, we recommend the use of shaft retention devices **part no. 28.0052/0**
- To use shaft locking devices on both sides, the shaft and shaft carrier should be at least 30 mm shorter than the total length.

RAIL 45X90 H

Part no.

28.0007/2

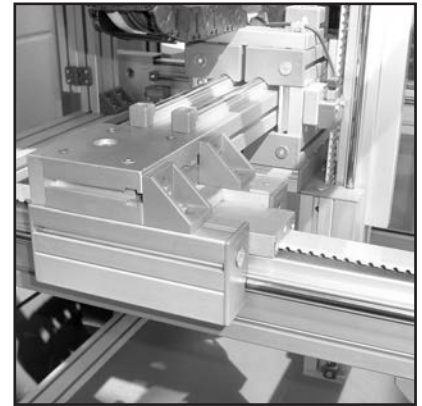
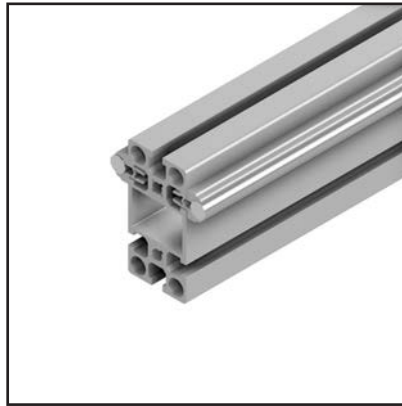
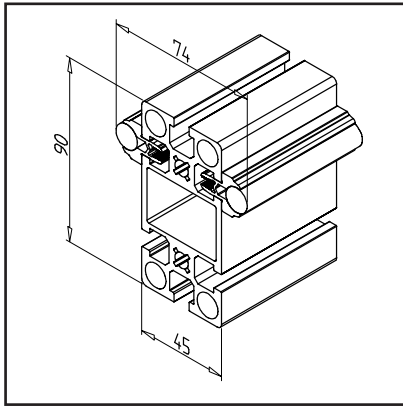
**TECHN. DATA / ITEMS SUPPLIED**

- Aluminium, anodized E6/EV1
- Profile 45 x 90
- On both sides with shaft supporting profile and shafts $\varnothing 12$ h6, pre-finished installed
- Without end caps
- Stainless version **part no. 28.0007/4**
- Weight = 6,190 kg/m
- Bar length = 6 m

APPLICATIONS

- Linear and column guides
- Belt return in profile
- Longer rails with composite shafts possible

ASSEMBLY

- For vertical use or for high speed applications, we recommend the use of shaft retention devices **part no. 28.0052/0**
- To use shaft locking devices on both sides, the shaft and shaft carrier should be at least 30 mm shorter than the total length.

RAIL 135 F

Part no.

28.0012/1

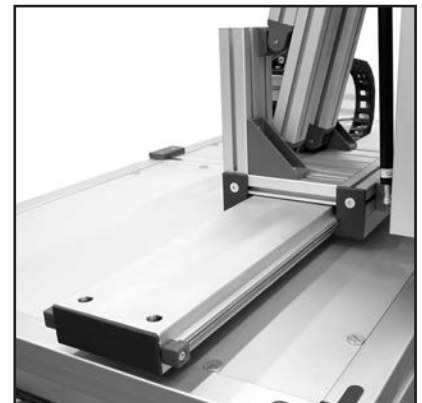
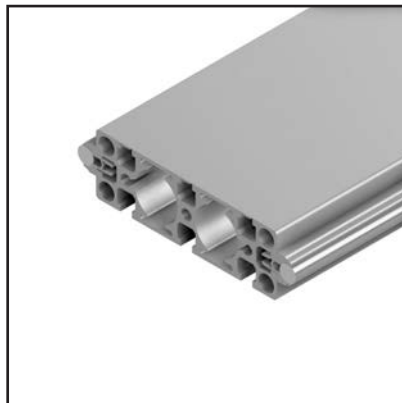
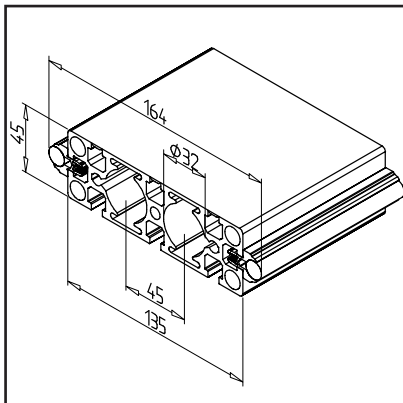
**TECHN. DATA / ITEMS SUPPLIED**

- Aluminium, anodized E6/EV1
- Profile 45 X 135 1G
- On both sides with shaft supporting profile and shafts $\varnothing 12$ h6, pre-finished installed
- Without end caps
- Stainless version **part no. 28.0012/3**
- Weight = 8,09 kg/m
- Bar length = 6 m

APPLICATIONS

- Linear and column guides
- Longer rails with composite shafts possible

ASSEMBLY

- For vertical use or for high speed applications, we recommend the use of shaft retention devices **part no. 28.0052/0**
- To use shaft locking devices on both sides, the shaft and shaft carrier should be at least 30 mm shorter than the total length.

RAIL 135 H

Part no.

28.0012/2

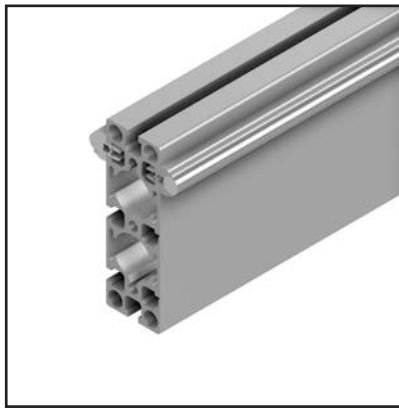
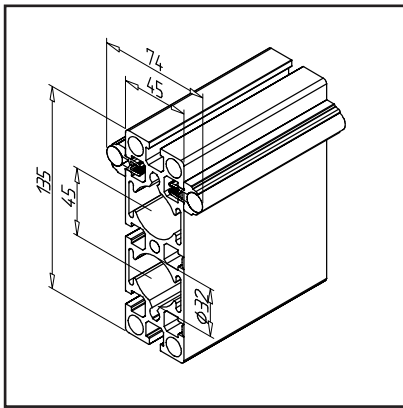
**TECHN. DATA / ITEMS SUPPLIED**

- Aluminium, anodized E6/EV1
- Profile 45 X 135 1G
- On both sides with shaft supporting profile and shafts Ø 12 h6, pre-finished installed
- Without end caps
- Stainless version **part no. 28.0012/4**
- Weight = 8,09 kg/m
- Bar length = 6 m

APPLICATIONS

- Linear and column guides
- Longer rails with composite shafts possible

ASSEMBLY

- For vertical use or for high speed applications, we recommend the use of shaft retention devices **part no. 28.0052/0**
- To use shaft locking devices on both sides, the shaft and shaft carrier should be at least 30 mm shorter than the total length.

RAIL 45X180 F

Part no.

28.0013/1

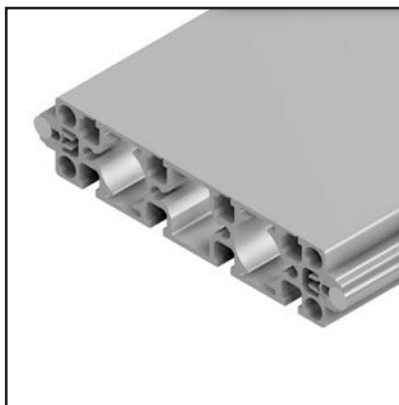
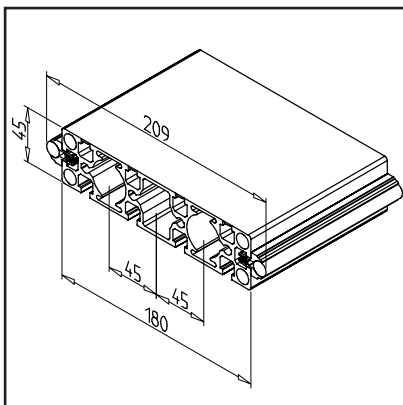
**TECHN. DATA / ITEMS SUPPLIED**

- Aluminium, anodized E6/EV1
- Profile 45 X 180 1G
- On both sides with shaft supporting profile and shafts Ø 12 h6, pre-finished installed
- Without end caps
- Stainless version **part no. 28.0013/3**
- Weight = 9,466 kg/m
- Bar length = 6 m

APPLICATIONS

- Linear and column guides
- Longer rails with composite shafts possible

ASSEMBLY

- For vertical use or for high speed applications, we recommend the use of shaft retention devices **part no. 28.0052/0**
- To use shaft locking devices on both sides, the shaft and shaft carrier should be at least 30 mm shorter than the total length.

RAIL 45X180 H

Part no.

28.0013/2

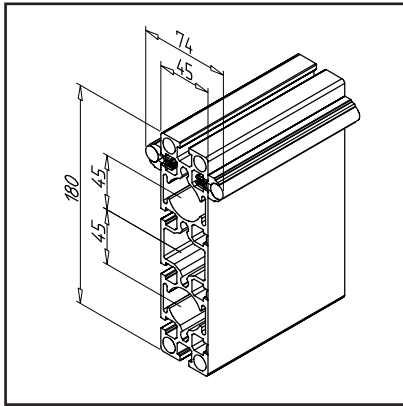
**TECHN. DATA / ITEMS SUPPLIED**

- Aluminium, anodized E6/EV1
- Profile 45 X 180 1G
- On both sides with shaft supporting profile and shafts \varnothing 12 h6, pre-finished installed
- Without end caps
- Stainless version **part no. 28.0013/4**
- Weight = 9,466 kg/m
- Bar length = 6 m

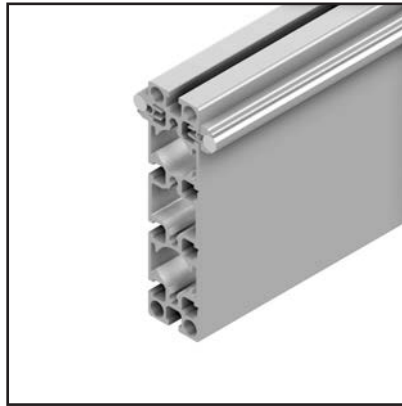
**APPLICATIONS**

- Linear and column guides
- Longer rails with composite shafts possible

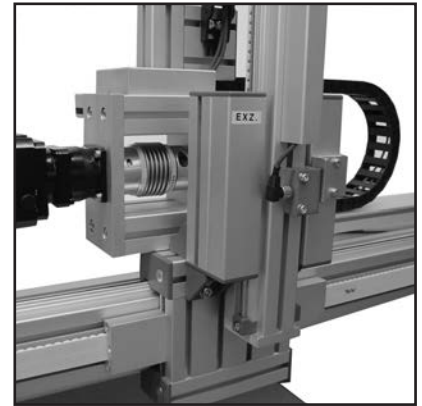
**ASSEMBLY**

- For vertical use or for high speed applications, we recommend the use of shaft retention devices **part no. 28.0052/0**
- To use shaft locking devices on both sides, the shaft and shaft carrier should be at least 30 mm shorter than the total length.

RAIL 90

Part no.

28.0008/0

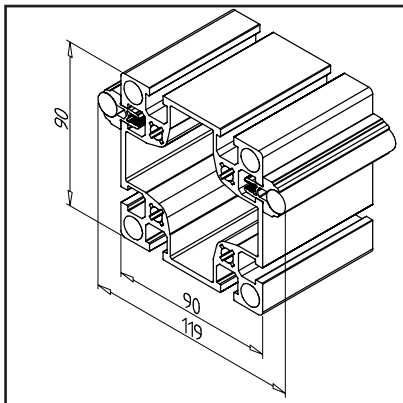
**TECHN. DATA / ITEMS SUPPLIED**

- Aluminium, anodized E6/EV1
- Profile 90 x 90 L
- On both sides with shaft supporting profile and shafts \varnothing 12 h6, pre-finished installed
- Without end caps
- Stainless version **part no. 28.0008/3**
- Weight = 7,88 kg/m
- Bar length = 6 m

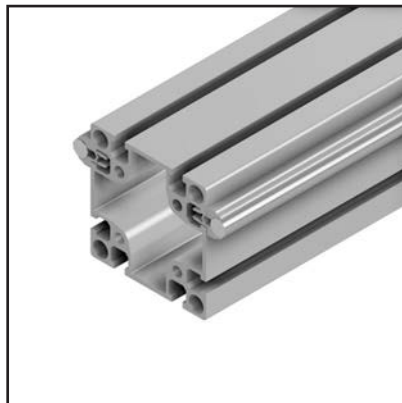
**APPLICATIONS**

- Linear and column guides for high load
- Belt return in profile
- Longer rails with composite shafts possible

**ASSEMBLY**

- For vertical use or for high speed applications, we recommend the use of shaft retention devices **part no. 28.0052/0**
- To use shaft locking devices on both sides, the shaft and shaft carrier should be at least 30 mm shorter than the total length.

RAIL 180 F

Part no. 28.0011/1

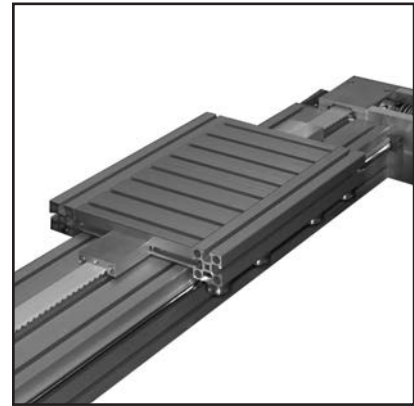
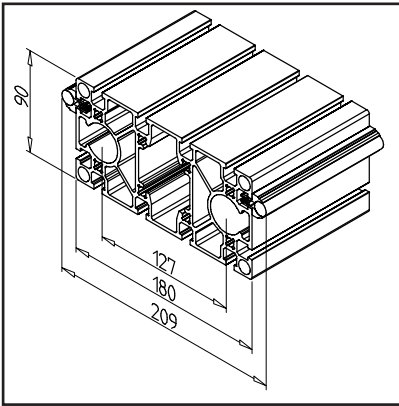

TECHN. DATA / ITEMS SUPPLIED

- Aluminium, anodized E6/EV1
- Profile 90 X 180 S
- On both sides with shaft supporting profile and shafts Ø 12 h6, pre-finished installed
- Without end caps
- Stainless version **part no. 28.0011/3**
- Weight = 14,516 kg/m
- Bar length = 6 m

APPLICATIONS

- Linear and column guides for high load
- Belt return in profile
- Longer rails with composite shafts possible

ASSEMBLY

- For vertical use or for high speed applications, we recommend the use of shaft retention devices **part no. 28.0052/0**
- To use shaft locking devices on both sides, the shaft and shaft carrier should be at least 30 mm shorter than the total length.

RAIL 180 H

Part no. 28.0011/2

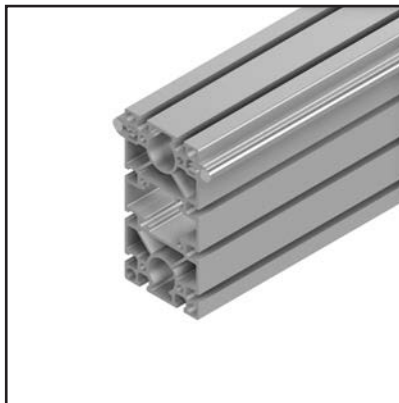
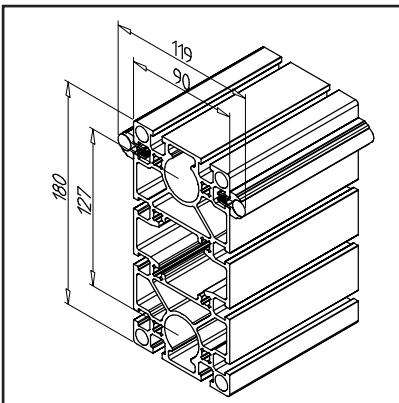

TECHN. DATA / ITEMS SUPPLIED

- Aluminium, anodized E6/EV1
- Profile 90 X 180 S
- On both sides with shaft supporting profile and shafts Ø 12 h6, pre-finished installed
- Without end caps
- Stainless version **part no. 28.0011/4**
- Weight = 14,516 kg/m
- Bar length = 6 m

APPLICATIONS

- Linear and column guides for high load
- Belt return in profile
- Longer rails with composite shafts possible

ASSEMBLY

- For vertical use or for high speed applications, we recommend the use of shaft retention devices **part no. 28.0052/0**
- To use shaft locking devices on both sides, the shaft and shaft carrier should be at least 30 mm shorter than the total length.

RAIL LR16 - 45X90H

Part no.

28.0820/0

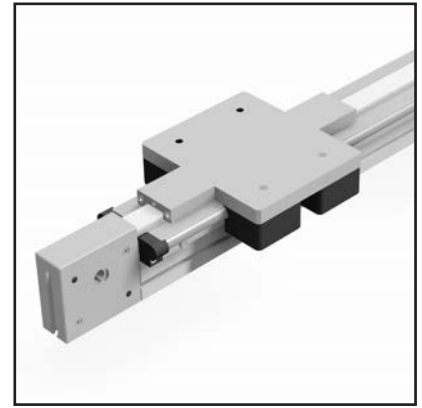
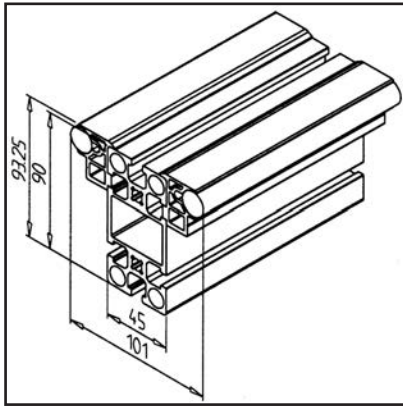
**TECHN. DATA / ITEMS SUPPLIED**

- Aluminium, anodized E6/EV1
- Profile 45 x 90
- On both sides with shaft carrier profile LR 16 and shafts \varnothing 16 h6, installed pre-assembled
- Without end caps
- Weight = 7,979 kg/m
- Bar length = 6 m

APPLICATIONS

- Linear and column guides for high load
- Belt return in profile
- Longer rails with composite shafts possible

ASSEMBLY

- For vertical use or high speed applications we recommend the use of shaft retention device LR 16 **part no. 28.0808/0** and **part no. 28.0809/0**
- To use shaft locking devices on both sides, the shaft and shaft carrier should be at least 30 mm shorter than the total length.

RAIL LR16 - 90X180H

Part no.

28.0822/0

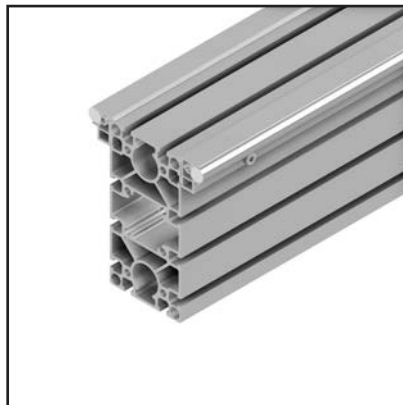
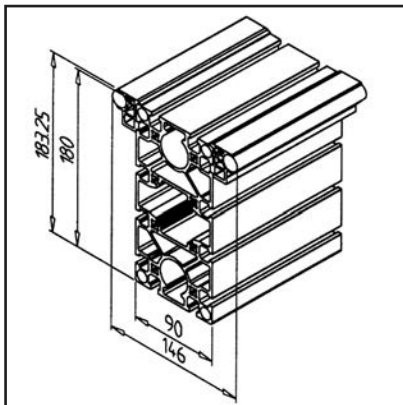
**TECHN. DATA / ITEMS SUPPLIED**

- Aluminium, anodized E6/EV1
- Profile 90 X 180 S
- On both sides with shaft carrier profile LR 16 and shafts \varnothing 16 h6, installed pre-assembled
- Without end caps
- Weight = 16,278 kg/m
- Bar length = 6 m

APPLICATIONS

- Linear and column guides for high load
- Belt return in profile
- Longer rails with composite shafts possible

ASSEMBLY

- For vertical use or high speed applications we recommend the use of shaft retention device LR 16 **part no. 28.0808/0** and **part no. 28.0809/0**
- To use shaft locking devices on both sides, the shaft and shaft carrier should be at least 30 mm shorter than the total length.

RAIL LR16 - 90

Part no.

28.0821/0

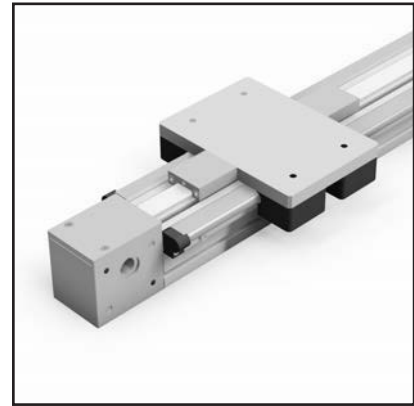
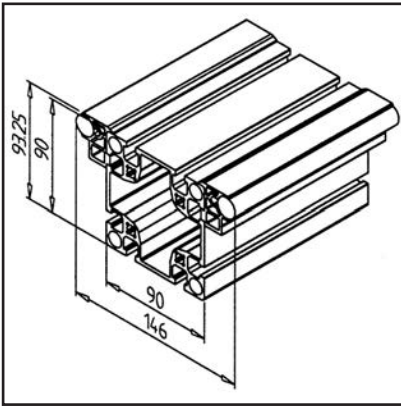

TECHN. DATA / ITEMS SUPPLIED

- Aluminium, anodized E6/EV1
- Profile 90 x 90 L
- On both sides with shaft carrier profile LR 16 and shafts $\varnothing 16$ h6, installed pre-assembled
- Without end caps
- Weight = 10,067 kg/m
- Bar length = 6 m

APPLICATIONS

- Linear and column guides for high load
- Belt return in profile
- Longer rails with composite shafts possible

ASSEMBLY

- For vertical use or high speed applications we recommend the use of shaft retention device LR 16 **part no. 28.0808/0** and **part no. 28.0809/0**
- To use shaft locking devices on both sides, the shaft and shaft carrier should be at least 30 mm shorter than the total length.

SHAFT 12

Part no.

17.1741/0

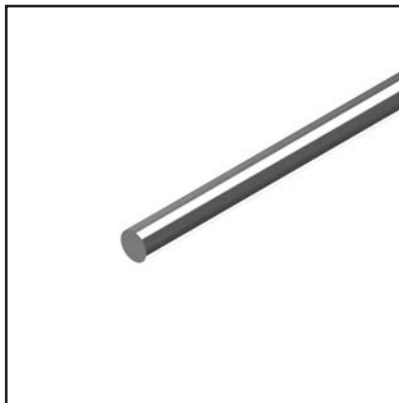
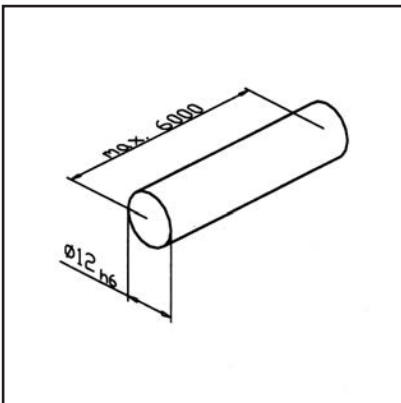

TECHN. DATA / ITEMS SUPPLIED

- Steel, pulled, hardened, polished
- Cf.53, hardened to 62 ± 4 HRC, polished h6
- Stainless version **part no. 17.1741/1**
- Weight = 0.888 kg/m
- Bar length = 6 m

APPLICATIONS

- All MiniTec-linear guides LR 12

ASSEMBLY

- Press shaft into supporting profile with appropriate tool (plastic mallet)
- For guides $L > 6000$ mm assemble shaft with offset joints

SHAFT SUPPORTING PROFILE LR 12

Part no.

28.0002/0

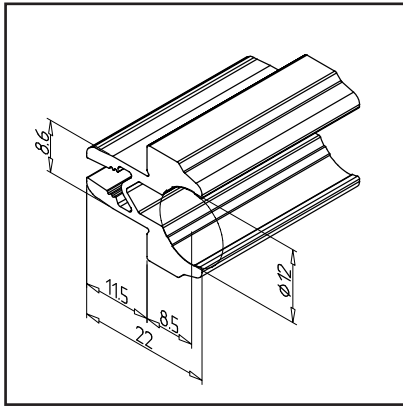

TECHN. DATA / ITEMS SUPPLIED

- Aluminium, extruded, anodized E6/EV1
- Weight = 0.370 kg/m
- Bar length = 6 m



APPLICATIONS

- MiniTec linear guides LR/LG

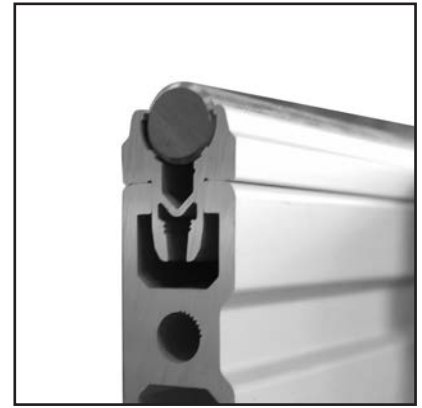

ASSEMBLY

- Press into the groove of rail profile
- If necessary clamp with set screw M5 x 10 in position
- Hammer the shaft into the rod holder profile with a plastic hammer

SHAFT LOCKING CLIP

Part no.

28.0052/0

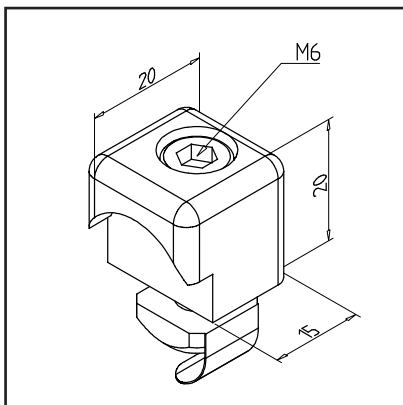

TECHN. DATA / ITEMS SUPPLIED

- Aluminium, Pressure die-casting, powder-coated, grey
- With fastening material steel, zinc plated
- Stainless version **part no. 28.0053/0**
- Weight = 0.026 kg/piece

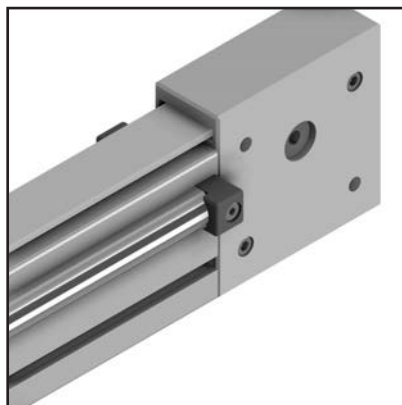

APPLICATIONS

- Axial fastening of shafts in dynamically stressed linear guides



ASSEMBLY

- Fasten the retention device at both shaft ends with fastening kit
- No machining required
- The shaft carrier profile and shafts must be 15 mm shorter than the carrier profile

SHAFT 16

Part no.

17.1743/0

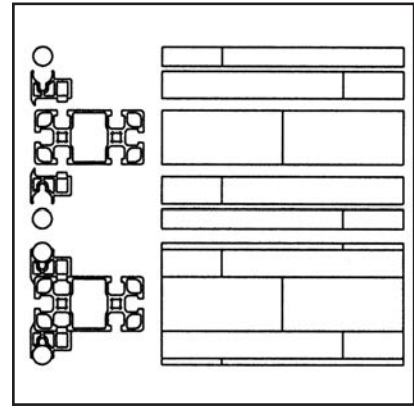
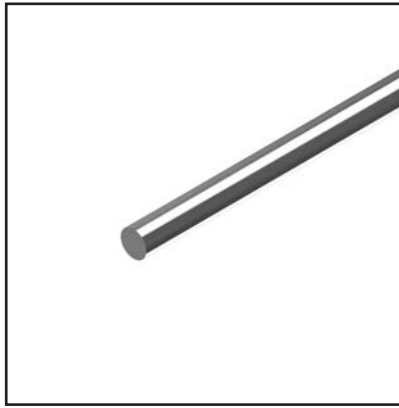
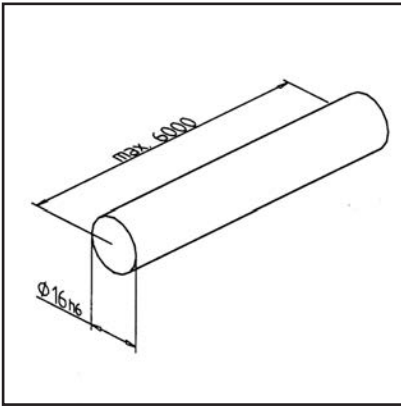

TECHN. DATA / ITEMS SUPPLIED

- Steel, pulled, hardened, polished
- Cf.53, hardened to 62 ± 4 HRC, polished h6
- Weight = 1.587 kg/m
- Bar length = 6 m

APPLICATIONS

- MiniTec linear guide LR 16

ASSEMBLY

- Press shaft into supporting profile with appropriate tool (plastic mallet)
- For guides $L > 6000$ mm assemble shaft with offset joints

SHAFT SUPPORTING PROFILE LR 16 WITHOUT BORE

Part no.

28.0019/0

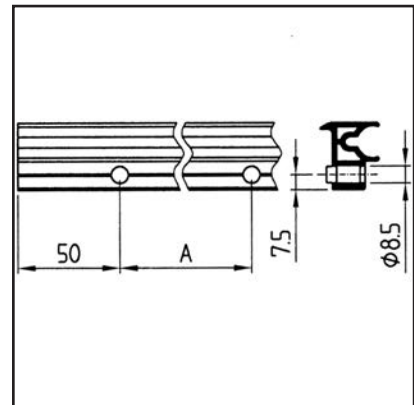
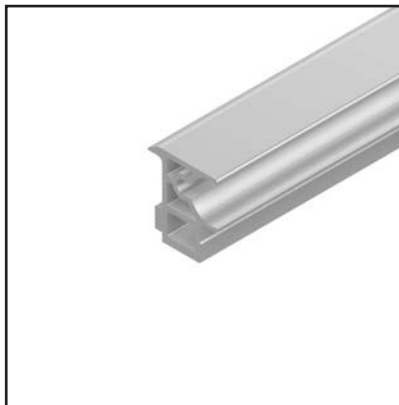
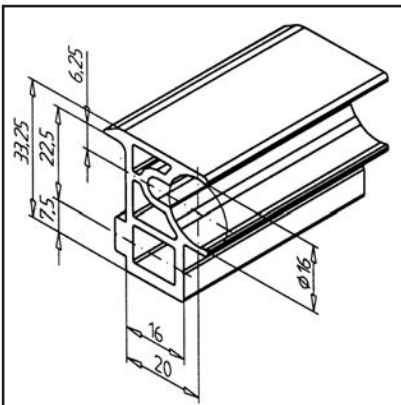

TECHN. DATA / ITEMS SUPPLIED

- Aluminium, extruded, anodized E6/EV1
- Please order design with bore at **part no. 28.0019/1**
grid dimension $A = 250$ mm
- Weight = 0.845 kg/m
- Bar length = 6 m

APPLICATIONS

- MiniTec linear guide LR16

ASSEMBLY

- Bore $\phi 8.5$ in the shaft supporting profile
- Recommended distance: 50 mm from the edge, then approximately every 200 - 300 mm
- Fasten to the support profile using cylinder screw M8 x 30 and sliding nut M8.
- Hammer the shaft into the rod holder profile with a plastic hammer

SHAFT LOCK LEFT LR16

Part no.

28.0809/0

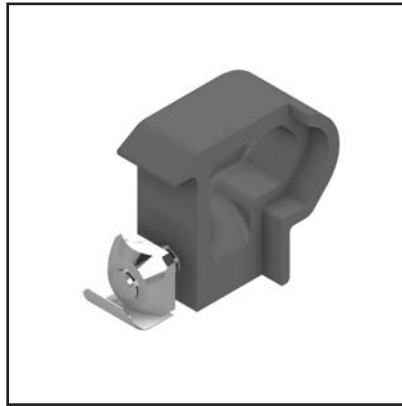
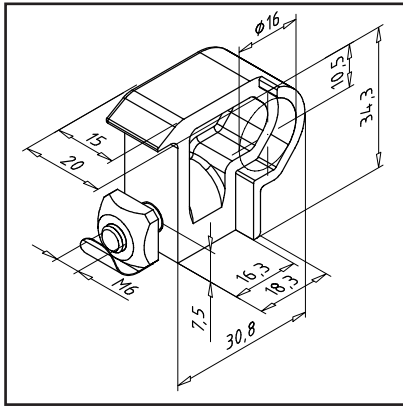
**TECHN. DATA / ITEMS SUPPLIED**

- Aluminium, Pressure die-casting, powder-coated, grey
- With fastening material steel, zinc plated
- Weight = 0.037 kg/piece

APPLICATIONS

- Axial fastening of shafts in dynamically stressed linear guides

ASSEMBLY

- Fasten the retention device at both shaft ends with fastening kit
- No machining required
- The shaft carrier profile and shafts must be 15 mm shorter than the carrier profile

SHAFT LOCK RIGHT LR16

Part no.

28.0808/0

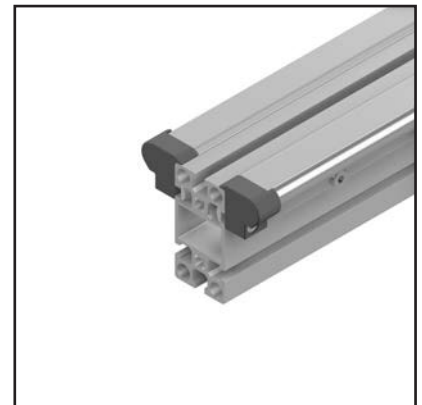
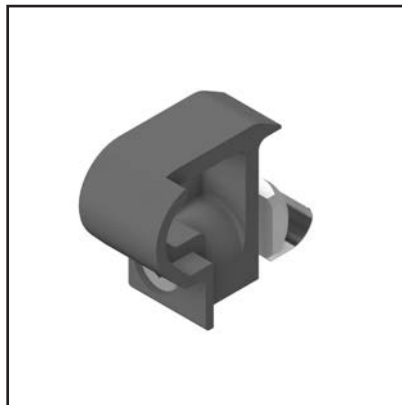
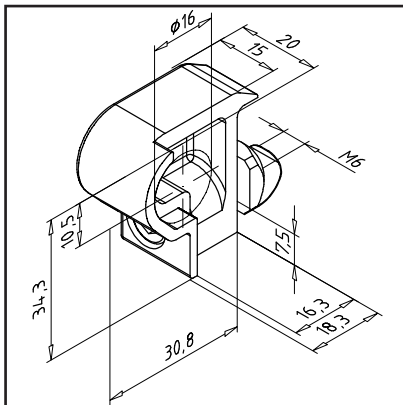
**TECHN. DATA / ITEMS SUPPLIED**

- Aluminium, Pressure die-casting, powder-coated, grey
- With fastening material steel, zinc plated
- Weight = 0.037 kg/piece

APPLICATIONS

- Axial fastening of shafts in dynamically stressed linear guides

ASSEMBLY

- Fasten the retention device at both shaft ends with fastening kit
- No machining required
- The shaft carrier profile and shafts must be 15 mm shorter than the carrier profile

SLIDE LR 6 COMPACT

Part no. 28.0140/0

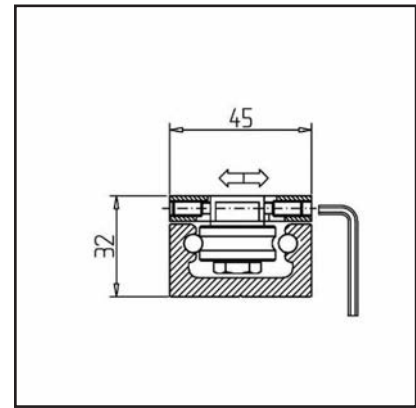
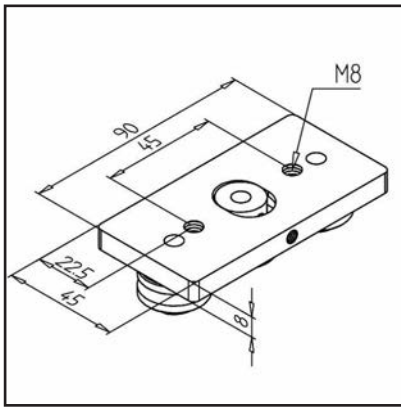

TECHN. DATA / ITEMS SUPPLIED

- Aluminium, anodized E6/EV1
- 3 double row casters LR 6
- Installed with concentric mounting bolts
- Stainless version **part no. 28.0148/0**
- Weight = 0.194 kg/piece

APPLICATIONS

- MiniTec linear guide systems LR 6
- Handling devices
- Guide large drawers
- Doors
- Rail **part no. 28.0119/0**

ASSEMBLY

- Slip slide onto rail
- Adjust casters with an Allen wrench SW 2.5 free play

SLIDE LR 6 Z COMPACT

Part no. 28.0520/0

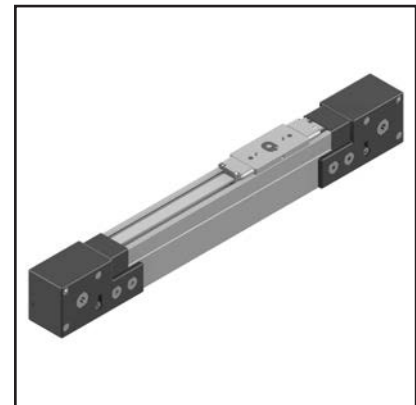
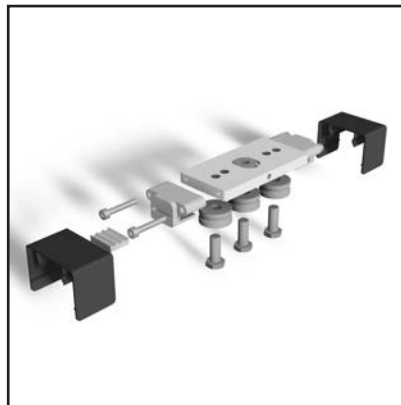
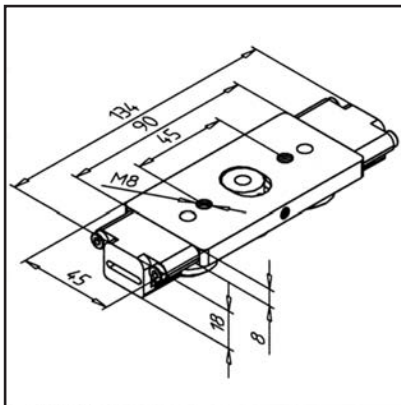

TECHN. DATA / ITEMS SUPPLIED

- Aluminium, anodized E6/EV1
- Aluminum carriage plate, machined on all sides
- 3 double row casters LR 6
- Installed with concentric mounting bolts
- Stainless version **part no. 28.0524/0**
- Weight = 0.192 kg/piece

APPLICATIONS

- MiniTec linear guide systems LR 6
- material-handling in areas with shortage of space
- Fitting rail LR6 compact **part no. 28.0119/0** and Timing belt pulley LR6

ASSEMBLY

- Slip slide onto rail
- Set the caster wheel with Allen wrench SW2 SW2.5 without play
- Set up the load to be carried on existing threads M8

SLIDE LR 6 COMPACT

Part no.

28.0127/0

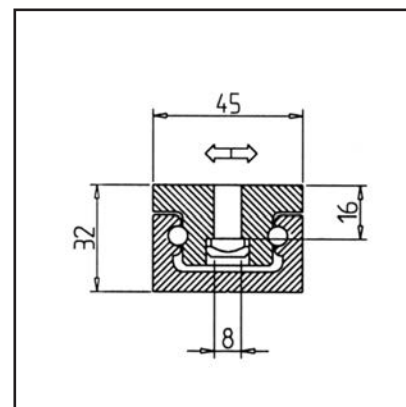
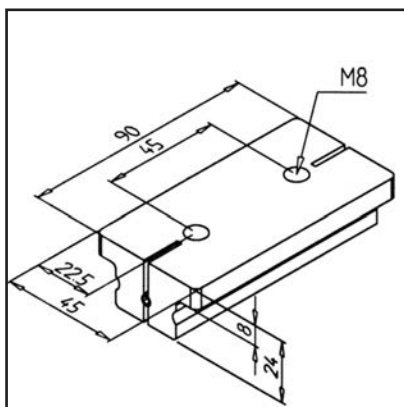
**TECHN. DATA / ITEMS SUPPLIED**

- PE-UHMW, black
- With square nut M8, steel zinc plated
- Weight = 0.068 kg/piece

APPLICATIONS

- Handling devices
- Guide large drawers
- Doors
- Rail **part no. 28.0119/0**

ASSEMBLY

- Slip slide onto rail
- Adjust slide clearance with hexagon key

SLIDE LR 6

Part no.

28.0138/0

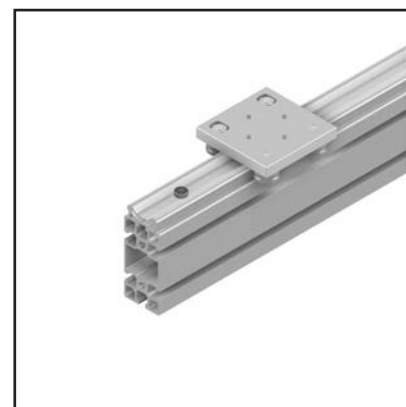
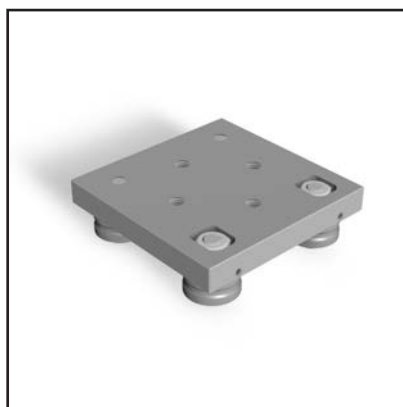
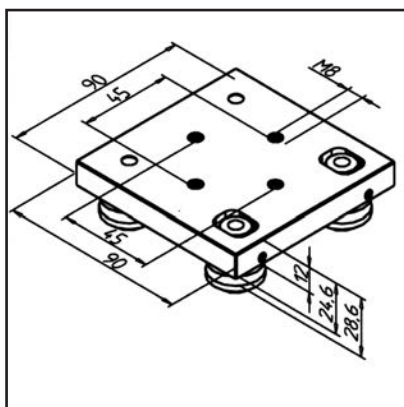
**TECHN. DATA / ITEMS SUPPLIED**

- Aluminium, anodized E6/EV1
- 4 double row casters LR 6
- Installed with concentric mounting bolts
- Stainless version **part no. 28.0139/0**
- Weight = 0.400 kg/piece

APPLICATIONS

- MiniTec linear guide systems LR 6
- Handling devices
- Doors
- For rail **part no. 28.0119/0**

ASSEMBLY

- Slip slide onto rail
- Adjust casters with an Allen wrench SW 2.5 free play
- Tighten casters with 15 Nm
- When used in extreme environment, use slide LR6 with cover, **part no. 28.0138/1**

SLIDE LR 6 WITH COVER

Part no. 28.0138/1

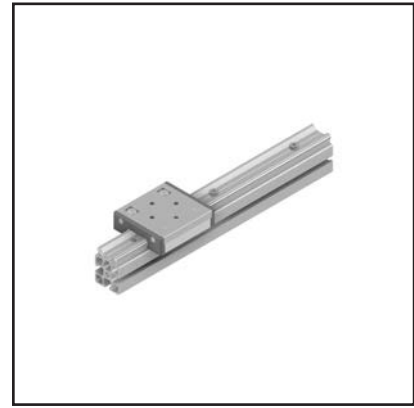
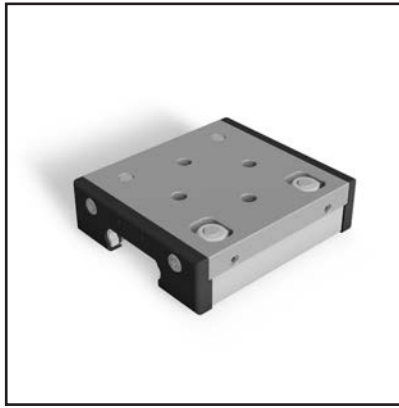
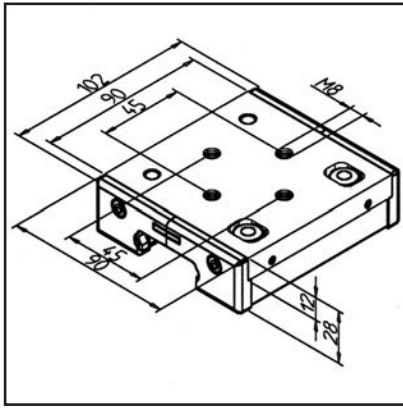

TECHN. DATA / ITEMS SUPPLIED

- Aluminium, anodized E6/EV1
- 4 double row casters LR 6
- Installed with concentric mounting bolts
- Covers with lubricating felt
- Stainless version **part no. 28.0139/1**
- Weight = 0.458 kg/piece

APPLICATIONS

- MiniTec linear guide systems LR 6
- Handling devices
- Guide large drawers
- Doors
- For rail **part no. 28.0119/0**

ASSEMBLY

- Slip slide onto rail
- Adjust casters with an Allen wrench SW 2.5 free play
- Tighten casters with 15 Nm
- Saturate greasing felts with appropriate oil

SLIDE LR 6 Z

Part no. 28.0138/2

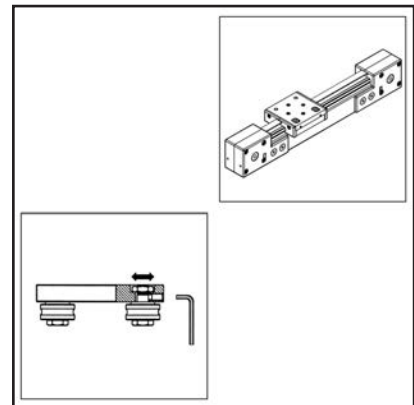
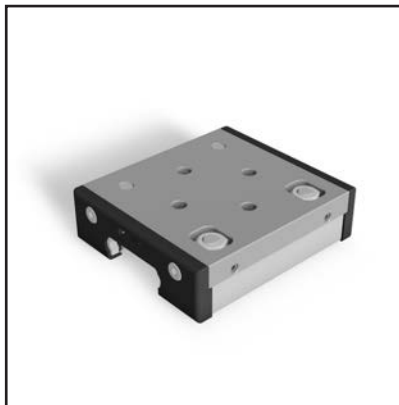
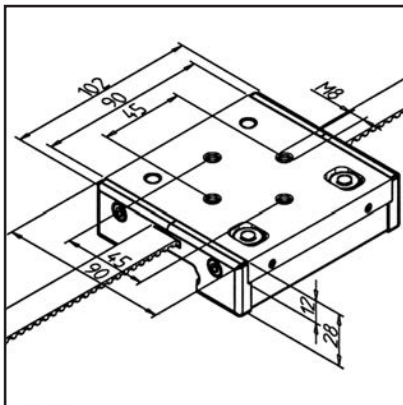

TECHN. DATA / ITEMS SUPPLIED

- Aluminium, anodized E6/EV1
- 4 double row casters LR 6
- Installed with concentric mounting bolts
- Covers with lubricating felt
- Integrated admission for timing belts
- Stainless version **part no. 28.0139/2**
- Weight = 0.502 kg/piece

APPLICATIONS

- MiniTec linear guide systems LR 6
- Handling devices
- For rail **part no. 28.0119/0**

ASSEMBLY

- Slip slide onto rail
- Adjust casters with an Allen wrench SW 2.5 free play
- Tighten casters with 15 Nm
- Insert the timing belt into the vehicle and fasten it
- Installed cover caps

SLIDE LW 32

Part no. 28.0088/0

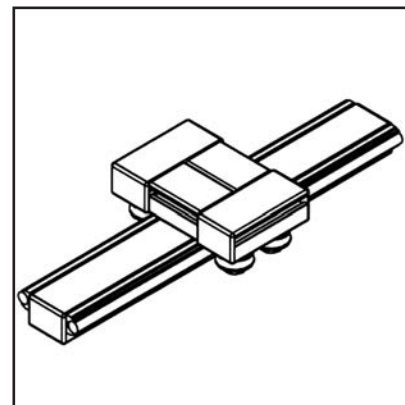
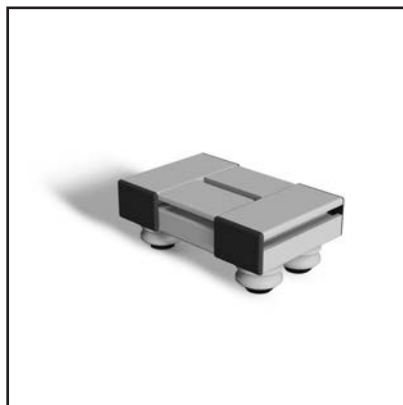
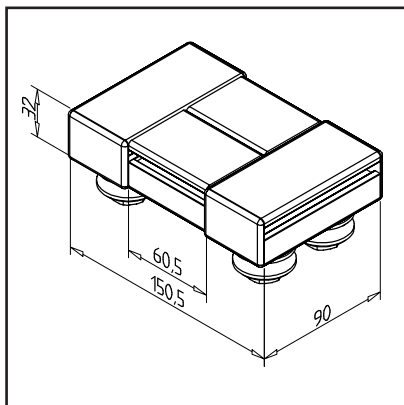
**TECHN. DATA / ITEMS SUPPLIED**

- Aluminium, anodized E6/EV1
- Fully mounted carriage
- 2 concentric and 2 eccentric bearing units
- End caps
- Stainless version **part no. 28.0088/1**
- Weight = 1.060 kg/piece

APPLICATIONS

- Handling devices
- Measuring devices
- Slide units
- For rails 19 and 32

ASSEMBLY

- Slip slide on rail 19 or 32; adjust clearance with eccentric bush

SLIDE LW 32 E

Part no. 28.0089/0

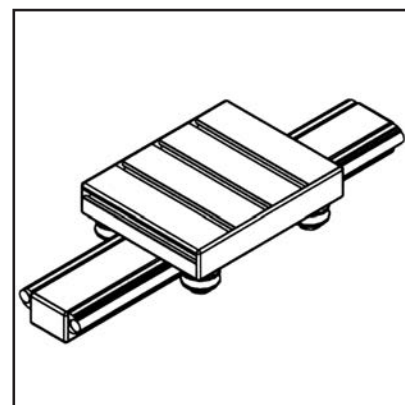
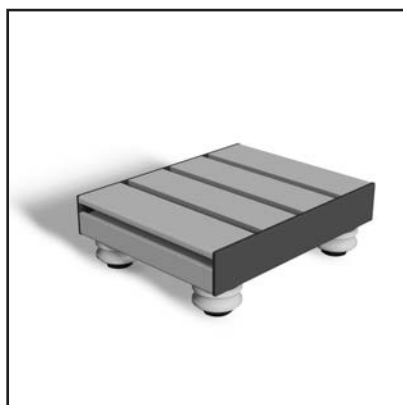
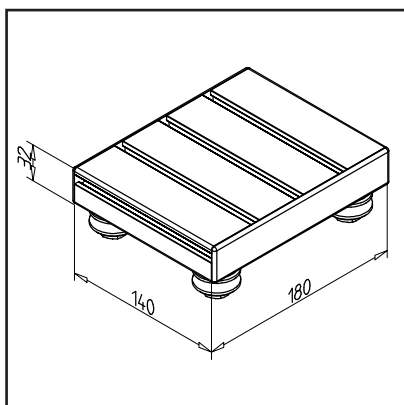
**TECHN. DATA / ITEMS SUPPLIED**

- Aluminium, anodized E6/EV1
- Fully mounted carriage
- 2 concentric and 2 eccentric bearing units
- End caps
- Stainless version **part no. 28.0089/1**
- Weight = 1.920 kg/piece

APPLICATIONS

- 1- or multi-axis guides
- Handling devices
- Measuring devices
- For rails 19 and 32

ASSEMBLY

- Slip slide on rail 19 or 32; adjust clearance with eccentric bush

SLIDE LW 45

Part no. 28.0091/0

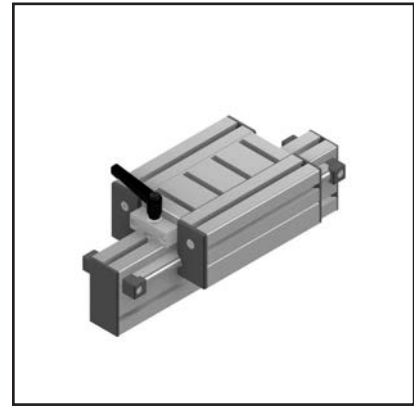
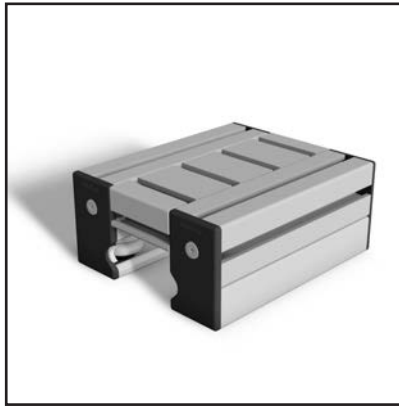
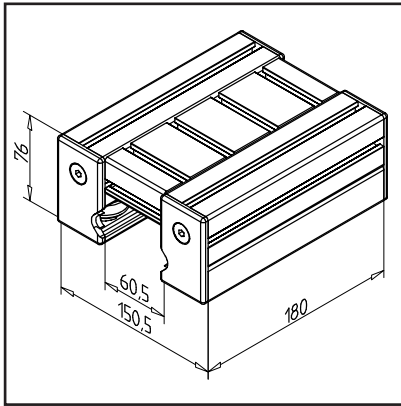

TECHN. DATA / ITEMS SUPPLIED

- Aluminium, anodized E6/EV1
- Fully mounted carriage
- 2 concentric and 2 eccentric bearing units
- End caps LR and 2 cover profiles LR
- Stainless version **part no. 28.0091/3**
- Weight = 2.260 kg/piece

APPLICATIONS

- 1- or multi-axis guides
- Linear robots
- Handling devices
- Measuring devices
- For rails 45, 45 x 90 H, 45 x 180 H and 135 H

ASSEMBLY

- Assemble slide on rail 45 or 45 x 90 H, adjust clearance with eccentric bush
- Install the cover and lubrication system
- Slide clamping unit **part no. 28.0270/0**

SLIDE LW 90

Part no. 28.0092/0

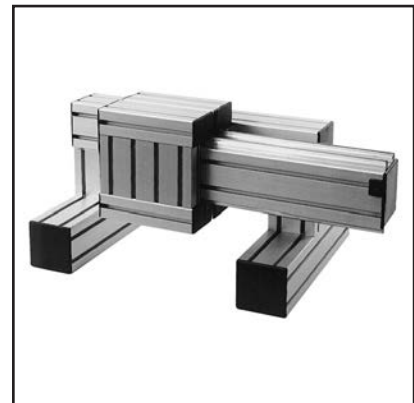
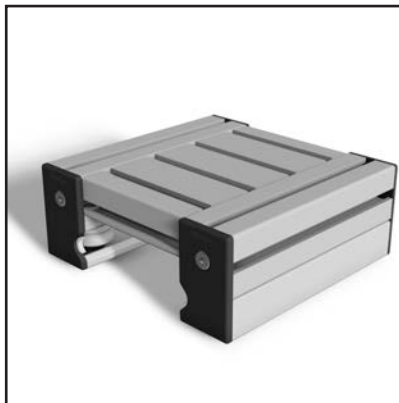
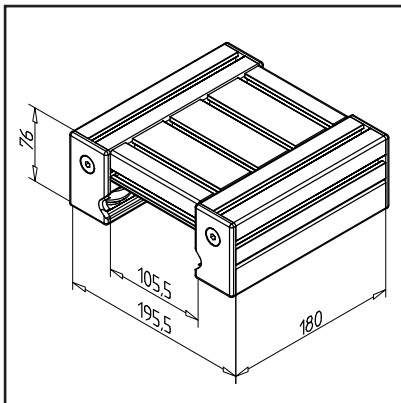

TECHN. DATA / ITEMS SUPPLIED

- Aluminium, anodized E6/EV1
- Fully mounted carriage
- 2 concentric and 2 eccentric bearing units
- End caps LR and Cover profiles LR
- **Stainless version part no. 28.0092/2**
- Weight = 2.720 kg/piece

APPLICATIONS

- 1- or multi-axis guides
- Linear robots
- Handling devices
- Measuring devices
- For rails 45 x 90 F, 90 x 90, 90 x 180 H

ASSEMBLY

- Assemble slide on rail 45 x 90 F, rail 90 or rail 90 x 180 H; adjust clearance with eccentric bush
- Install the cover and lubrication system
- Slide clamping unit **part no. 28.0270/0**

SLIDE LW 135

Part no.

28.0084/0

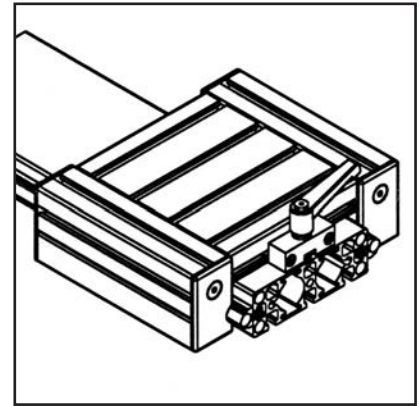
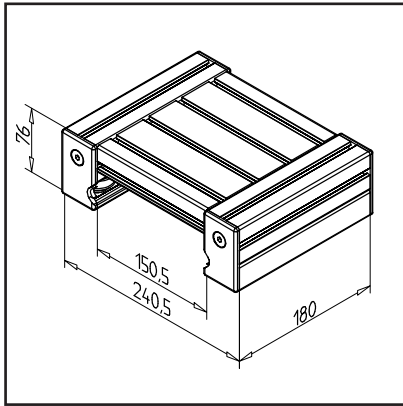
**TECHN. DATA / ITEMS SUPPLIED**

- Aluminium, anodized E6/EV1
- Fully mounted carriage
- 2 concentric and 2 eccentric bearing units
- End caps LR and Cover profiles LR
- Stainless version **part no. 28.0084/1**
- Weight = 3.150 kg/piece

APPLICATIONS

- 1- or multi-axis guides
- Linear robots
- Handling devices
- Measuring devices
- For rails 135 F

ASSEMBLY

- Assemble slide on rail 45 x 135; adjust clearance with eccentric bush
- Install the cover and lubrication system
- Slide clamping unit **part no. 28.0270/0**

SLIDE LW 180

Part no.

28.0087/0

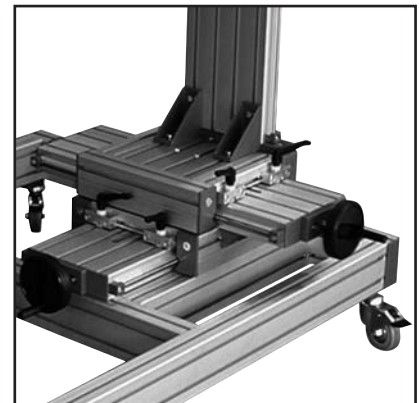
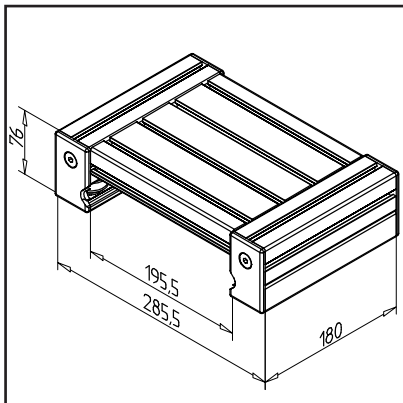
**TECHN. DATA / ITEMS SUPPLIED**

- Aluminium, anodized E6/EV1
- Fully mounted carriage
- 2 concentric and 2 eccentric bearing units
- End caps LR and Cover profiles LR
- Stainless version **part no. 28.0087/1**
- Weight = 3.590 kg/piece

APPLICATIONS

- 1- or multi-axis guides
- Linear robots
- Handling devices
- Measuring devices
- For rails 45 x 180 F and 90 x 180 F

ASSEMBLY

- Assemble slide on rail 90 x 180; adjust clearance with eccentric bush
- Install the cover and lubrication system
- Slide clamping unit **part no. 28.0270/0**

SLIDE LW 180 WITH 8 BEARINGS

Part no. 28.0087/3

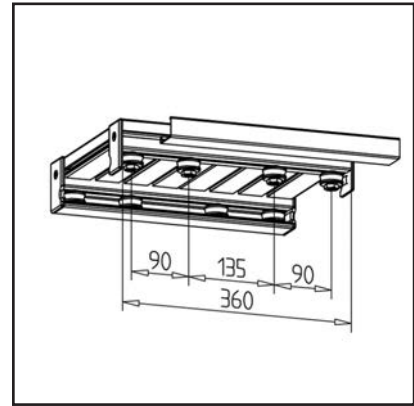
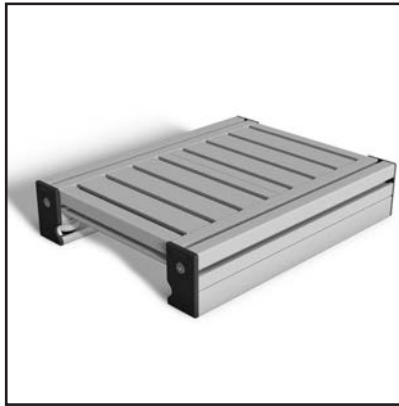
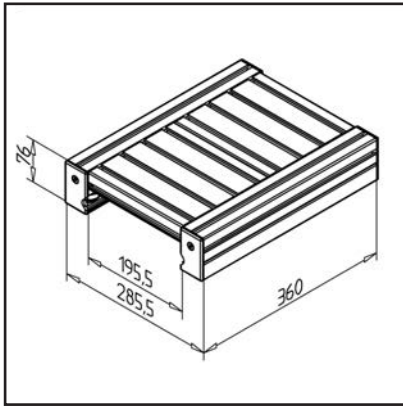

TECHN. DATA / ITEMS SUPPLIED

- Aluminium, anodized E6/EV1
- Fully mounted carriage
- With 8 concentric and 8 eccentric bearing units
- End caps LR and Cover profiles LR
- Stainless version **part no. 28.0087/1**
- Weight = 7.379 kg/piece

APPLICATIONS

- 1- or multi-axis guides
- Linear robots
- Handling devices
- Measuring devices
- For rails 45 x 180 F and 90 x 180 F

ASSEMBLY

- Assemble slide on rail 90 x 180; adjust clearance with eccentric bush
- Install the cover and lubrication system
- Slide clamping unit **part no. 28.0270/0**

SLIDE LR 16 - 45

Part no. 28.0810/0

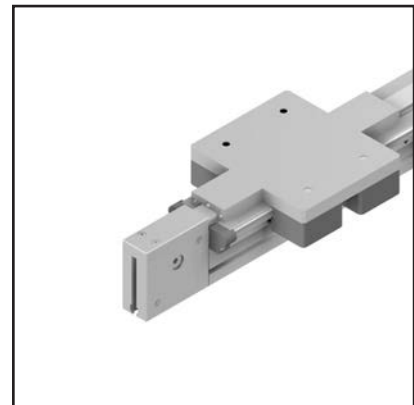
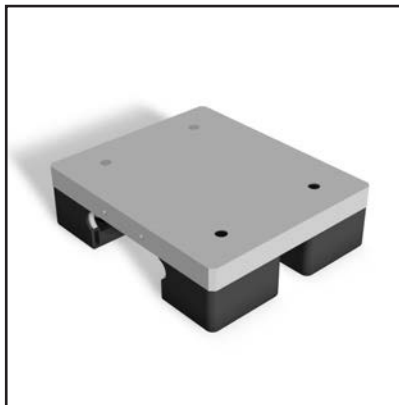
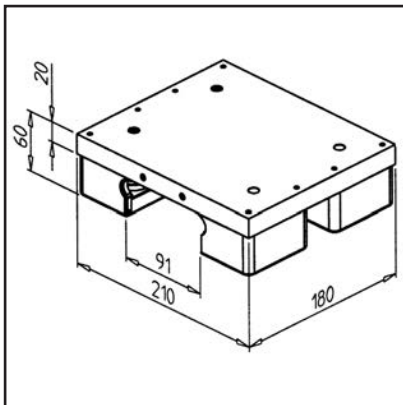

TECHN. DATA / ITEMS SUPPLIED

- Aluminium, anodized E6/EV1
- 2 concentric and 2 eccentric bearing units
- Weight = 3.638 kg/piece

APPLICATIONS

- 1- or multi-axis guides
- Linear robots
- Handling devices
- Measuring devices
- For rail LR16 45 x 90 H

ASSEMBLY

- Push the trolley onto the rails, adjust for zero play with eccentric fastening set
- Install the cover and lubrication system

SLIDE LR 16 - 90

Part no.

28.0811/0

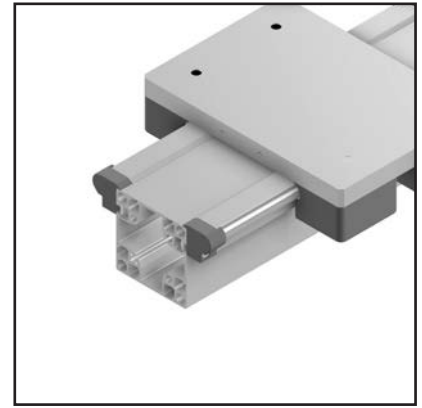
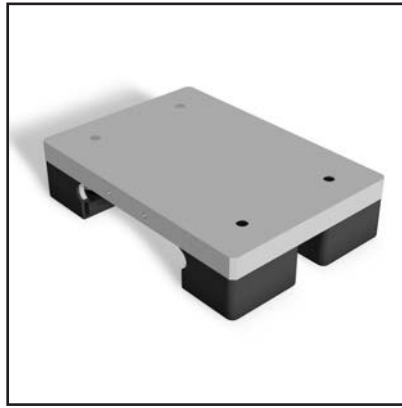
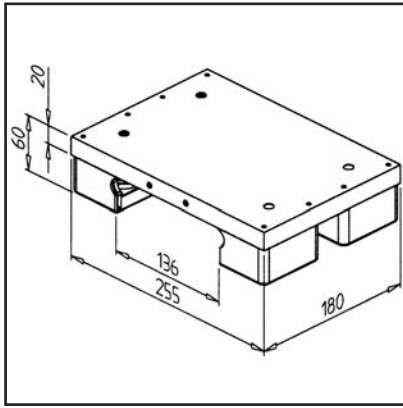
**TECHN. DATA / ITEMS SUPPLIED**

- Aluminium, anodized E6/EV1
- Fully mounted carriage
- 2 concentric and 2 eccentric bearing units
- Weight = 4.076 kg/piece

APPLICATIONS

- 1- or multi-axis guides
- Linear robots
- Handling devices
- Measuring devices
- For rail LR16 90 and LR16 90x180 H

ASSEMBLY

- Push the trolley onto the rails, adjust for zero play with eccentric fastening set
- Install the cover and lubrication system

BELT DRIVE 45

Part no.

28.0248/0

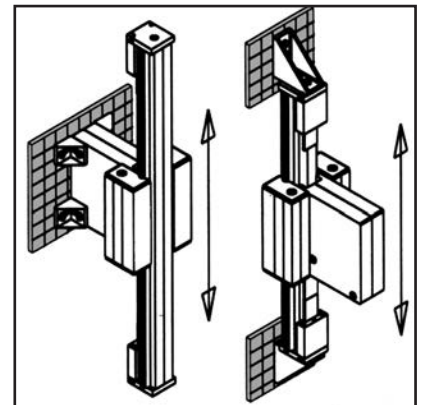
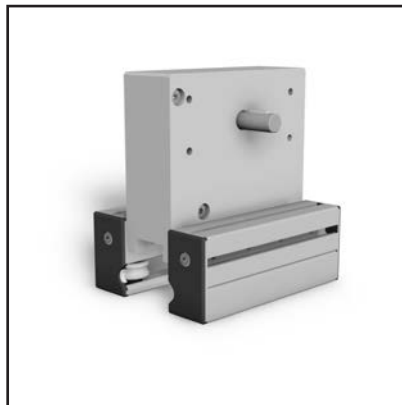
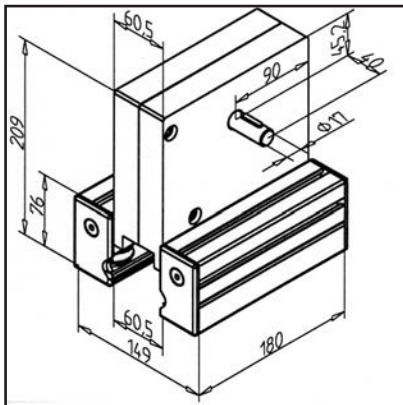
**TECHN. DATA / ITEMS SUPPLIED**

- Aluminium, anodized E6/EV1
- Shaft end $\varnothing 17$ for motor connection
- 2 idler pulleys aluminium, integrated in linear slide LW 45
- Weight = 6.320 kg/piece

APPLICATIONS

- MiniTec linear guides LR with extremely long travels, z-axis
- Use with rail 45, 45 x 90 H, 45 x 135 H and 45 x 180 H

ASSEMBLY

- Guide the timing belt through the timing belt drive, slide it onto the rail and adjust it without play
- Fix timing belt end to rail end with timing belt tensioner **part no. 28.0090/0** and fastening plate for rail 45 **part no. 28.0054/0** or for rail 45 x 90 H **part no. 28.0056/0**
- Tighten the timing belt
- Belt length: Rail length + 212 mm

BELT DRIVE 90

Part no.

28.0249/0

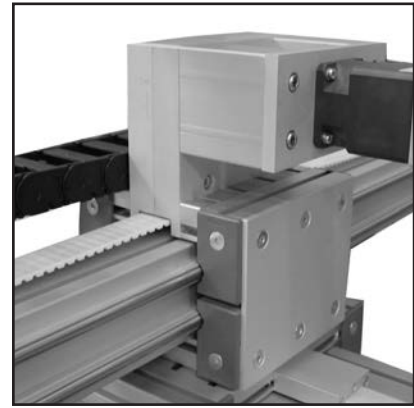
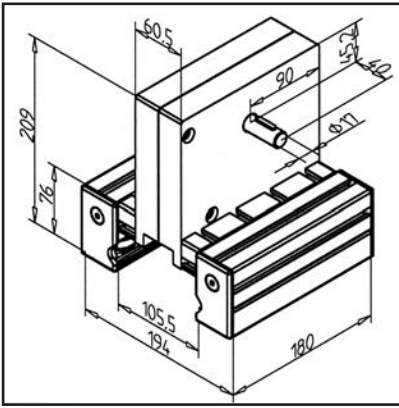

TECHN. DATA / ITEMS SUPPLIED

- Aluminium, anodized E6/EV1
- Shaft end $\varnothing 17$ for motor connection
- 2 idler pulleys aluminium, integrated in linear slide LW 90
- Weight = 6.789 kg/piece

APPLICATIONS

- MiniTec linear guides LR with extremely long travels, z-axis
- Use with rail 45 x 90 F, rail 90 or 90 x 180 H

ASSEMBLY

- Guide the timing belt through the timing belt drive, slide it onto the rail and adjust it without play
- Fix timing belt end to rail end with timing belt tensioner **part no. 28.0090/0** and fastening plate for rail 90 **part no. 28.0057/0** or for rail 45 x 90 F **part no. 28.0055/0**
- Tighten the timing belt
- Belt length: Rail length + 212 mm

FASTENING KIT FOR TIMING BELT TENSIONER 45 X 90 H

Part no.

28.0056/0

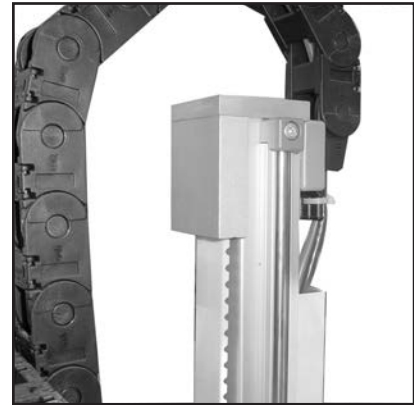
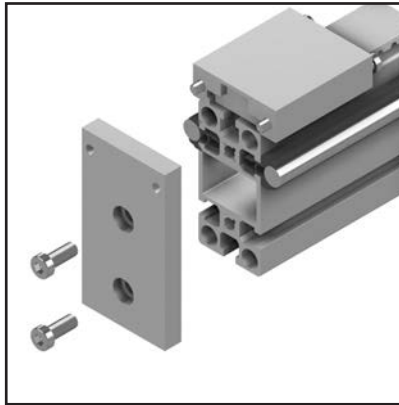
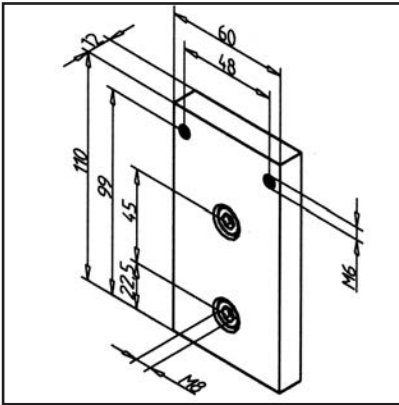

TECHN. DATA / ITEMS SUPPLIED

- Aluminium, anodized E6/EV1
- With fastening material steel, zinc plated
- Weight = 0.090 kg/piece

APPLICATIONS

- For each timing belt tensioner one fastening kit is necessary
- Connection of timing belt tensioner to rail 45 x 90 H in connection with timing belt drive

ASSEMBLY

- Fasten with supplied hardware to the end of the rail, then introduce thread M8
- Install timing belt tensioner

FASTENING KIT FOR TIMING BELT TENSIONER 45

Part no.

28.0054/0

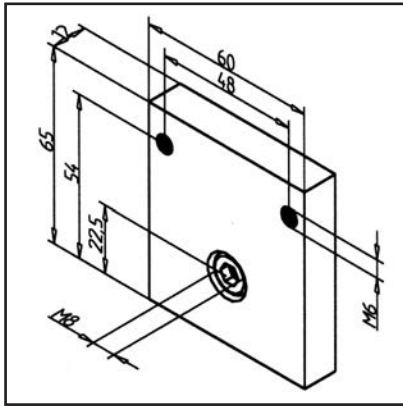
**TECHN. DATA / ITEMS SUPPLIED**

- Aluminium, anodized E6/EV1
- With fastening material steel, zinc plated
- Weight = 0.090 kg/piece

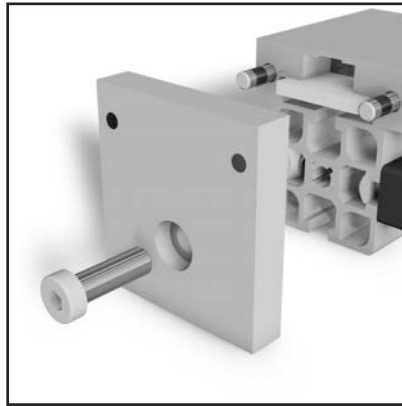
**APPLICATIONS**

- **In connection with belt drive**
- For each timing belt tensioner one fastening kit is necessary
- Connection of timing belt tensioner to rail 45

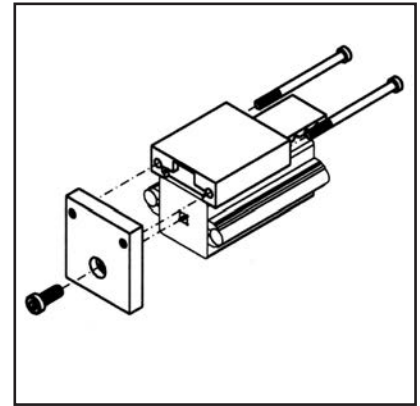
**ASSEMBLY**

- Fasten with supplied hardware to the end of the rail, then introduce thread M8
- Install timing belt tensioner

FASTENING KIT FOR TIMING BELT TENSIONER 45 X 90 F

Part no.

28.0055/0

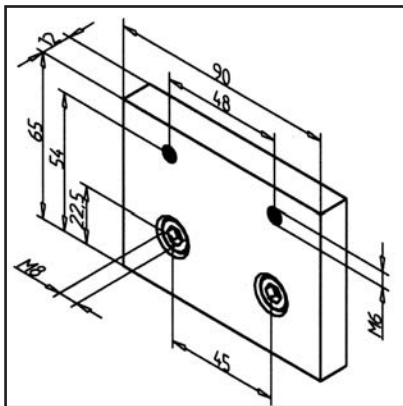
**TECHN. DATA / ITEMS SUPPLIED**

- Aluminium, anodized E6/EV1
- With fastening material steel, zinc plated
- Weight = 0.090 kg/piece

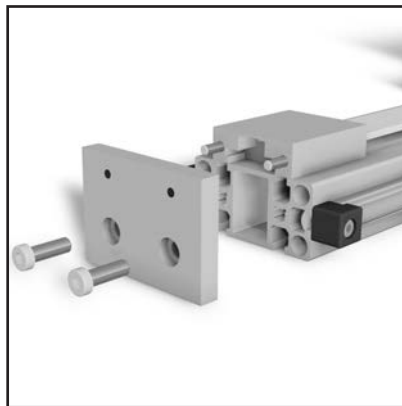
**APPLICATIONS**

- For each timing belt tensioner one fastening kit is necessary
- Connection of timing belt tensioner to rail 45 x 90 F in conjunction with timing belt drive

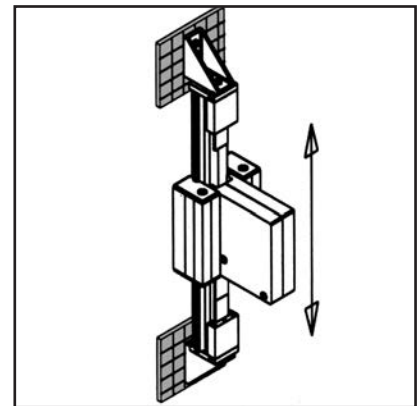
**ASSEMBLY**

- Fasten with supplied hardware to the end of the rail, then introduce thread M8
- Install timing belt tensioner

FASTENING KIT FOR TIMING BELT TENSIONER 90

Part no. 28.0057/0

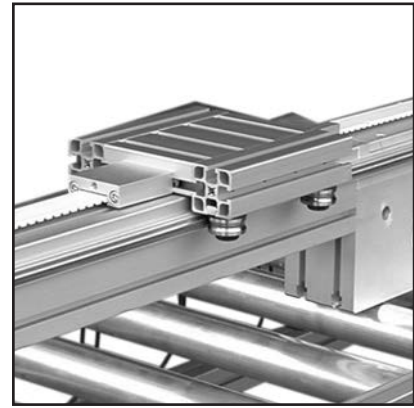
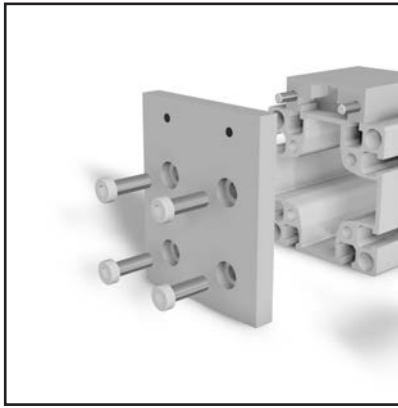
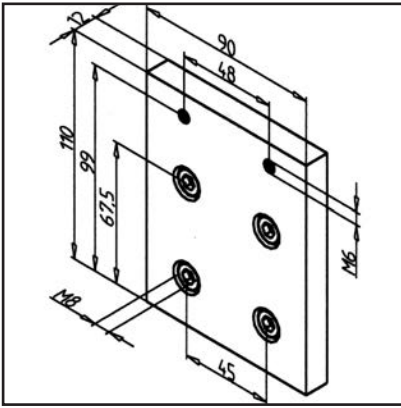

TECHN. DATA / ITEMS SUPPLIED

- Aluminium, anodized E6/EV1
- With fastening material steel, zinc plated
- Weight = 0.090 kg/piece

APPLICATIONS

- For each timing belt tensioner one fastening kit is necessary
- Connection of timing belt tensioner to rail 90 in conjunction with timing belt drive

ASSEMBLY

- Fasten with supplied hardware to the end of the rail, then introduce thread M8
- Install timing belt tensioner

BALL BEARING LR 12

Part no. 28.0001/0

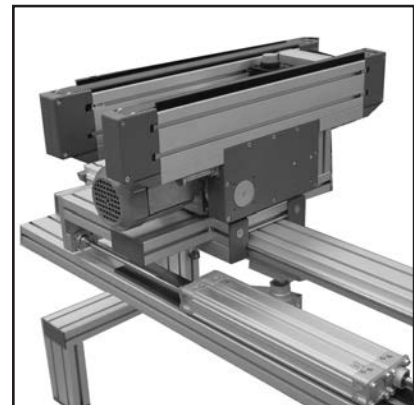
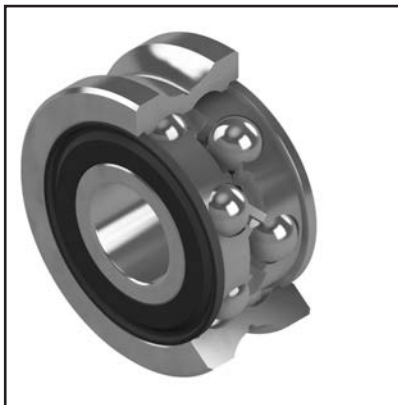
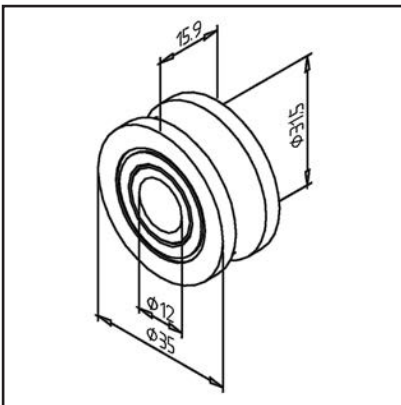

TECHN. DATA / ITEMS SUPPLIED

- Steel, hardened, polished
- 2-row angular ball bearing, wave groove executed as Gothic arch
- For shaft $\varnothing 12$
- Load capacity:
- dyn. $C = 10,5$ kN
- stat. $C_0 = 6,0$ kN
- Stainless version **part no. 28.0001/1**
- Weight = 0.068 kg/piece

APPLICATIONS

- All MiniTec-linear guides LR 12

ASSEMBLY

- Fastening kit LRK **part no. 28.0021/0** or LRE **part no. 28.0022/0**

BALL BEARING LR 12 L

Part no.

28.0005/0

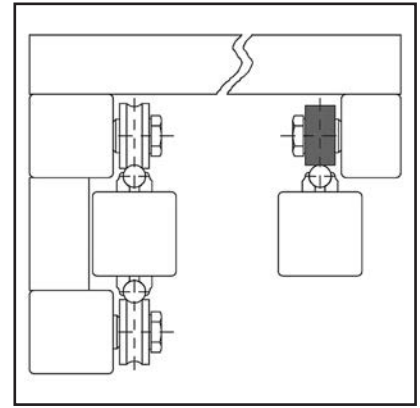
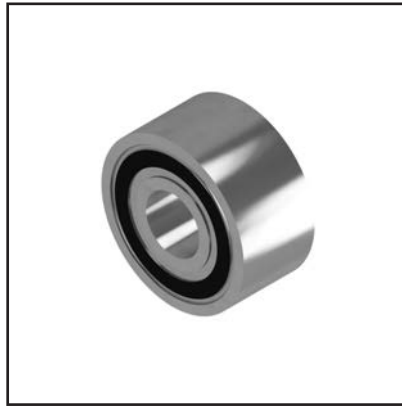
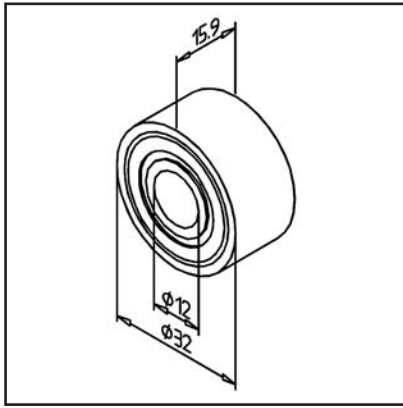
**TECHN. DATA / ITEMS SUPPLIED**

- Steel, hardened, polished
- Double-row angular contact bearing
- Load capacity:
- dyn. C = 8,6 kN
- stat. C₀ = 5,1 kN
- Weight = 0.053 kg/piece

APPLICATIONS

- Construction of MiniTec linear guidance systems with fixed and floating bearing block
- Compensation of distance deviations in parallel linear systems

ASSEMBLY

- Fastening kit LRK **part no. 28.0021/0** or LRE **part no. 28.0022/0**

FASTENING KIT LRK

Part no.

28.0021/0

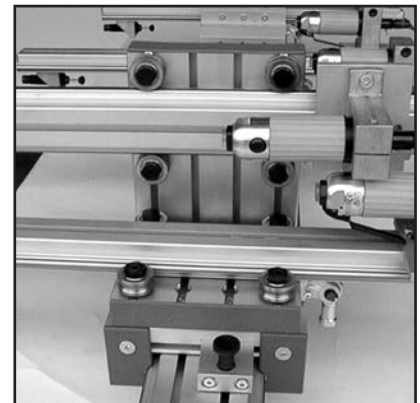
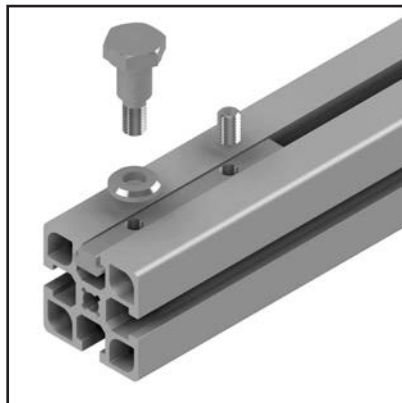
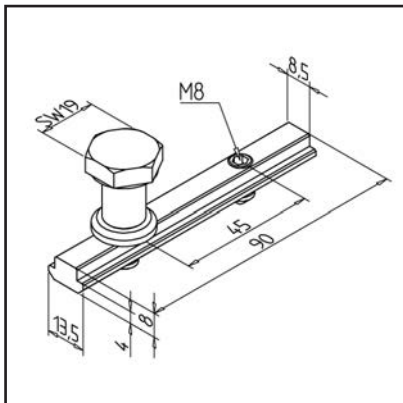
**TECHN. DATA / ITEMS SUPPLIED**

- 1 T-slot bar, steel, zinc plated with set screw
- Bolt M8 concentric, steel, black bronze finish
- Spacer 3.5 mm, polished, steel, black bronze finish
- Stainless version **part no. 28.0021/1**
- Weight = 0.100 kg/piece

APPLICATIONS

- MiniTec-linear guides LR 12
- Concentric attachment of ball bearings LR 12

ASSEMBLY

- Fit the clamping strips into the underside of the profile of the carriage plate, the threaded pins being fastened into the center of the carriage
- The two threaded holes M8 without threaded pins are designed to receive the mounting bolts
- Pass the bolt through the bearing hole, place the spacer washer, and tighten with key SW 19 to the clamping strip
- Recommended torque: 25 Nm

FASTENING KIT LRE

Part no. 28.0022/0

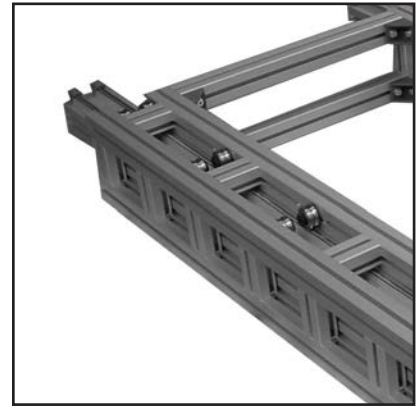
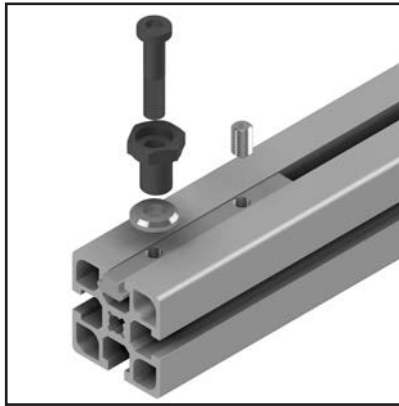
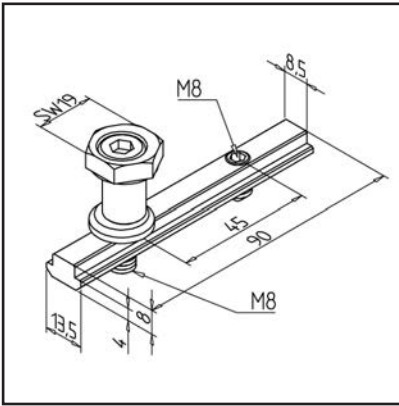

TECHN. DATA / ITEMS SUPPLIED

- 1 T-slot bar, steel, zinc plated with set screw
- Eccentric bushing, steel, black bronze finish
- Bolt M8 concentric, steel, black bronze finish
- Spacer 3.5 mm, polished, steel, black bronze finish
- Stainless version **part no. 28.0022/1**
- Weight = 0.100 kg/piece

APPLICATIONS

- MiniTec-linear guides LR 12
- Concentric attachment of ball bearings LR 12

ASSEMBLY

- Fit the clamping strip similar to LRK
- Insert bolt M8 into the eccentric bushing pre-installed in the bearing bore and place the spacer washer. Pre-tighten the bolt with the Allen wrench SW4 onto the clamping bar
- Adjust bush with ring spanner width 19 mm (turn for freedom from clearance with 0,9 - 1 Nm) and fix bolt
- Recommended torque: 25 Nm

END CAP LR (RIGHT)

Part no. 28.0004/1

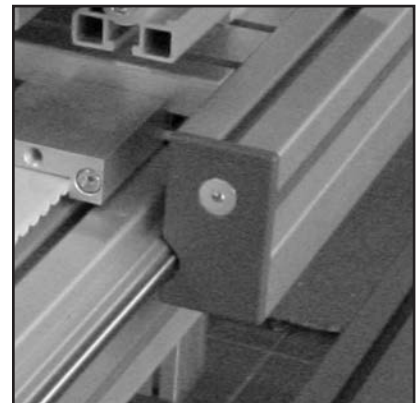
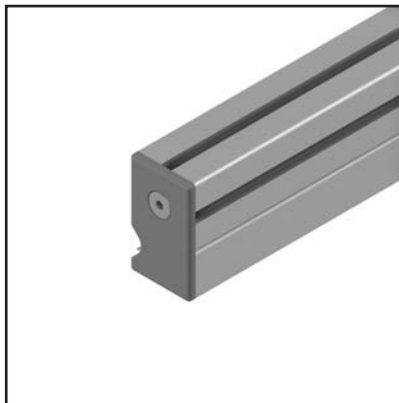
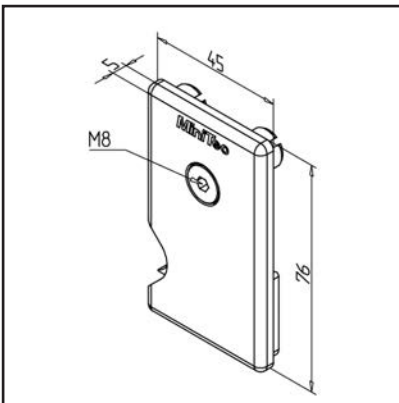

TECHN. DATA / ITEMS SUPPLIED

- ABS, Injection Mould, grey
- With integrated, sprung wiping and lubrication felt
- Fastening kit
- Also available in black, **part no. 28.0004/0**
- Weight = 0.031 kg/piece

APPLICATIONS

- All MiniTec-linear guides LR 12

ASSEMBLY

- Insert the lubricated felts and press fastening peg in profile 45 x 45 of the slide plate
- Fasten with supplied hardware
- Insert cover profile between the end caps
- Clean and soak felt according to implementation conditions or use a spare felt **part no. 28.0004/8**

END CAP LR (LEFT)

Part no.

28.0004/3

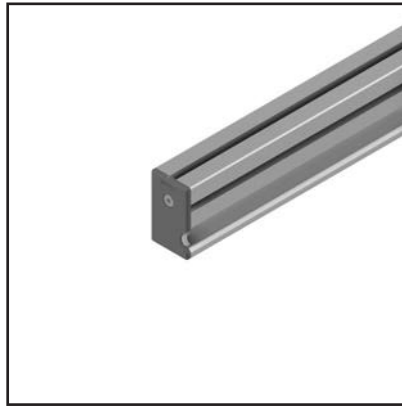
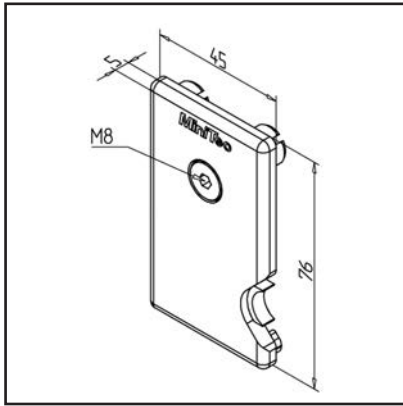
**TECHN. DATA / ITEMS SUPPLIED**

- ABS, Injection Mould, grey
- With integrated, sprung wiping and lubrication felt
- Fastening kit
- Also available in black, **part no. 28.0004/2**
- Weight = 0.031 kg/piece

APPLICATIONS

- All MiniTec-linear guides LR 12

ASSEMBLY

- Insert the lubricated felts and press fastening peg in profile 45 x 45 of the slide plate
- Fasten with supplied hardware
- Insert cover profile between the end caps
- Clean and soak felt according to implementation conditions or use a spare felt **part no. 28.0004/8**

COVER PROFILE LR

Part no.

28.0049/0

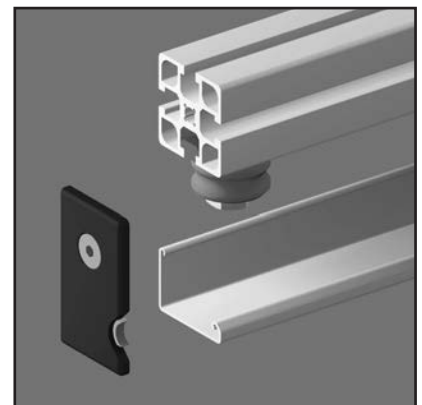
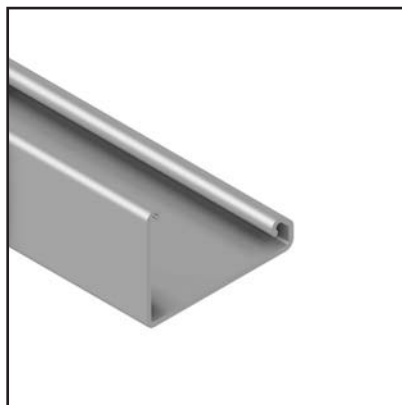
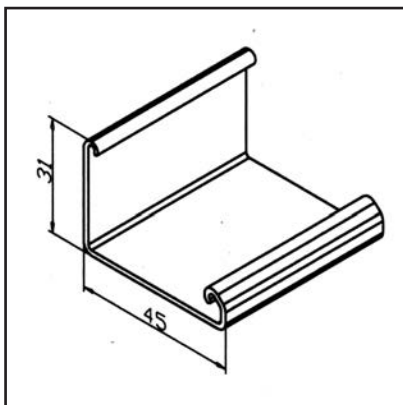
**TECHN. DATA / ITEMS SUPPLIED**

- Aluminium, extruded, anodized E6/EV1
- Weight = 0.362 kg/m
- Bar length = 6 m

APPLICATIONS

- MiniTec-linear guides LR 12

ASSEMBLY

- Cut profile according to the length of the slide
- Insert the cover profile between the end caps; insert the felts; fasten the end caps LR on the slide by means of the supplied screws

SLIDE CLAMPING UNIT (TOP) LWG / LWN / LW

Part no.

28.0270/0

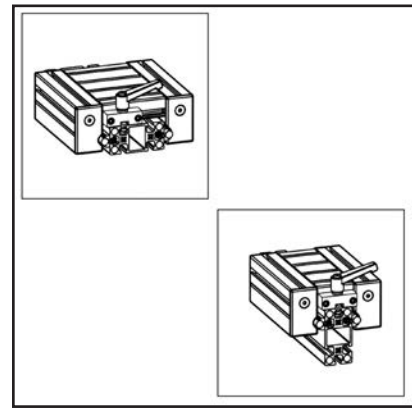
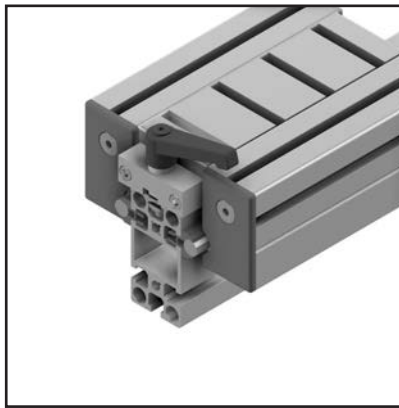
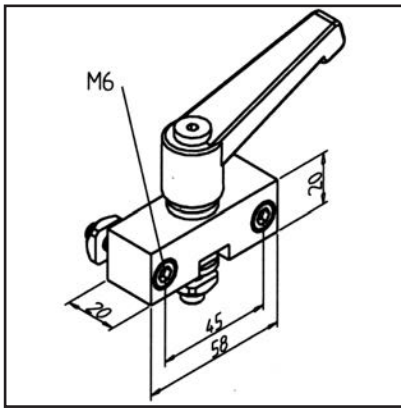

TECHN. DATA / ITEMS SUPPLIED

- Aluminium, anodized E6/EV1
- With fastening material steel, zinc plated
- With clamping device
- Weight = 0.199 kg/piece

APPLICATIONS

- Clamping of MiniTec slide LW and slides LWN / LWG on rail surface
- Clamping of MiniTec adjusting units

ASSEMBLY

- Preadjust clamping shaft and lead it in profile groove
- Insert plastic element
- Install the housing block
- Secure clamping lever with installation glue Loctite 243

BALL BEARING LR 16

Part no.

50.1726/0

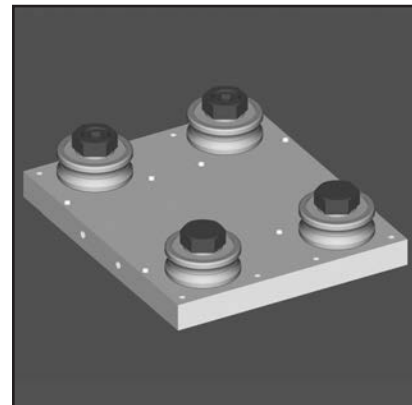
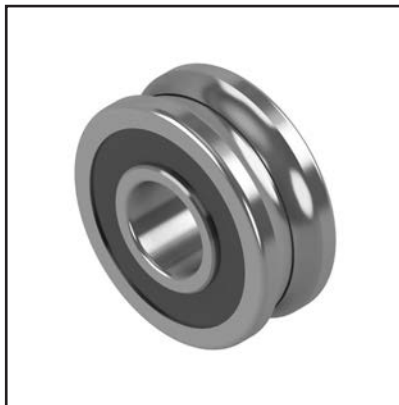
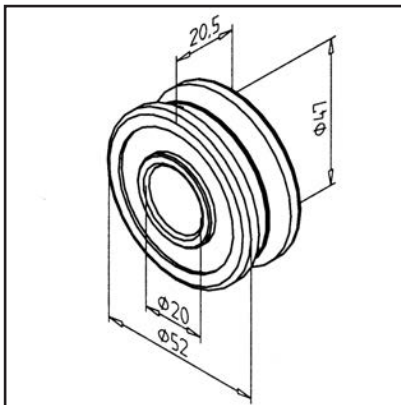

TECHN. DATA / ITEMS SUPPLIED

- Steel, hardened, polished
- 2-row angular ball bearing, wave groove executed as Gothic arch
- For shaft $\varnothing 16$
- Load capacity:
- dyn. $C = 19,90$ kN
- stat. $C_0 = 12,60$ kN
- Weight = 0.230 kg/piece

APPLICATIONS

- MiniTec linear guide LR16

ASSEMBLY

- Fastening using concentric bolts, **part no. 28.0814/0** or adjustable with eccentric bushing **part no. 28.0813/0** and screw M 12x40 **part no. 21.1257/0**

END CAP LR 16

Part no.

28.0815/0

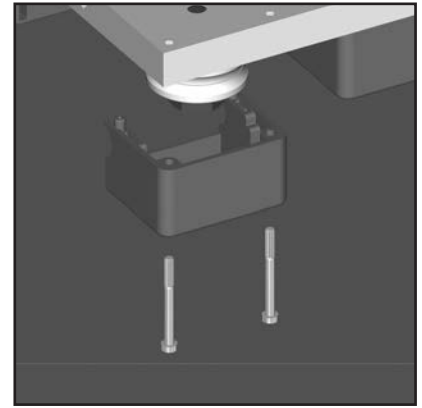
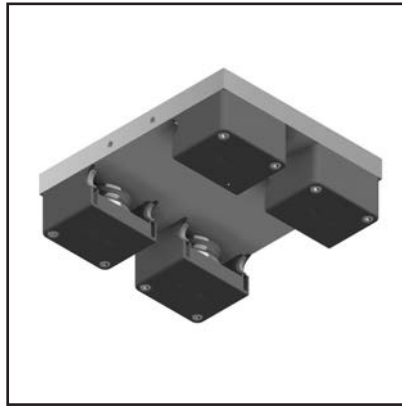
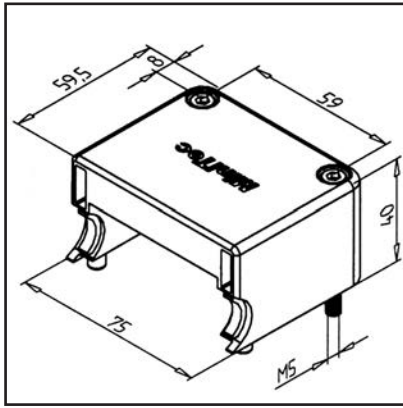
**TECHN. DATA / ITEMS SUPPLIED**

- PA, Injection Mould, grey
- With fastening material steel, zinc plated
- With integrated, sprung wiping and lubrication felt
- Weight = 0.071 kg/piece

APPLICATIONS

- MiniTec linear guide LR16

ASSEMBLY

- Fasten with supplied hardware
- Clean and soak fillet according to implementation conditions or spare fillet **part no. 28.0816/0**

BOLT CONCENTRIC LR 16

Part no.

28.0814/0

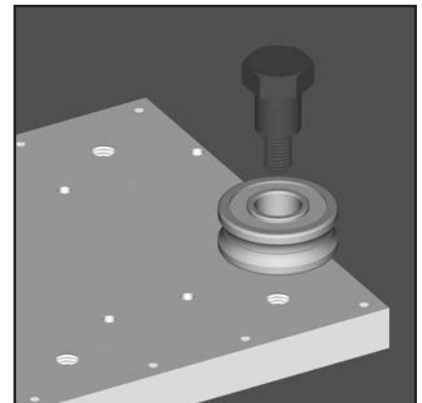
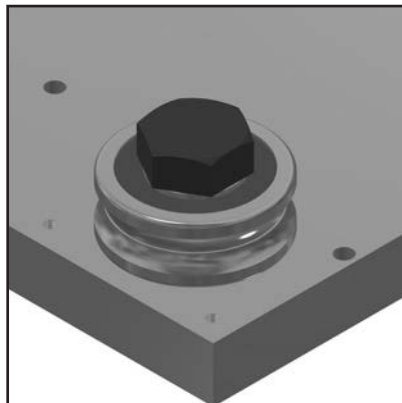
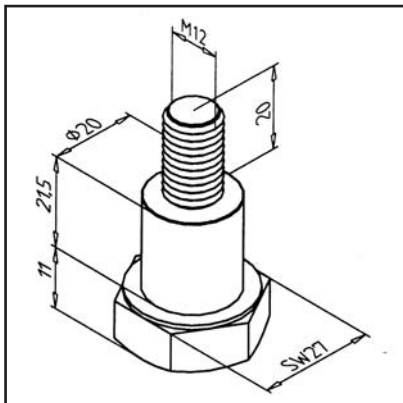
**TECHN. DATA / ITEMS SUPPLIED**

- Steel, burnished, black
- Bolt M12 concentric
- Weight = 0.121 kg/piece

APPLICATIONS

- MiniTec linear guide LR16
- Concentric mounting of ball bearings LR 16

ASSEMBLY

- MiniTec linear guides LR 16
- Recommended torque: 50 Nm

ECCENTRIC BUSHING LR 16

Part no.

28.0813/0

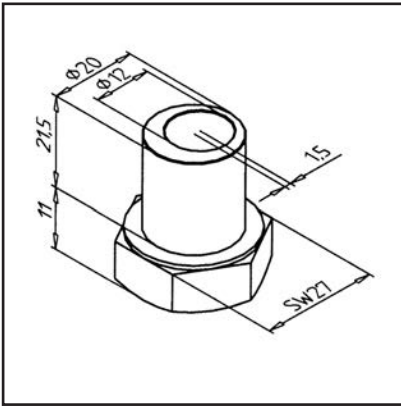

TECHN. DATA / ITEMS SUPPLIED

- Steel, burnished, black
- Weight = 0.059 kg/piece



APPLICATIONS

- MiniTec linear guide LR16
- Eccentric fastening of ball bearings LR 16

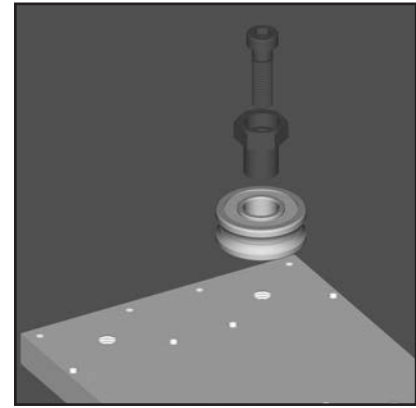

ASSEMBLY

- Screw M12 x 45 **part no. 21.1157/0** Insert in eccentric bushing and mount loose with bearing
- Adjust the bearing by turning the eccentric bush with the spanner (wrench size 27) for zero play (with 0.9 - 1 Nm torque resistance) and hold the eccentric bush in this position. Tighten the bolt.
- Recommended torque: 50 Nm

TIMING BELT PULLEY

LR6 & LR6 COMPACT / T45 (LR12 + LR16)

LR 6 & LR 6 COMPACT

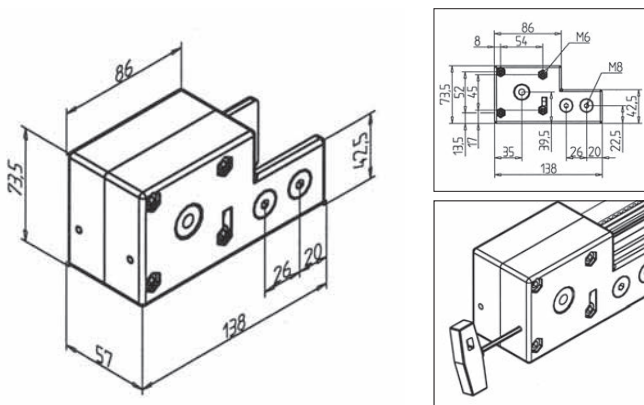

Techn. Data/Items supplied

Aluminum GD, powder coated, grey
Body complete with pulley

Application

- For MiniTec linear guides LR 6 Z

Assembly

- Insert sliding nut M8 into rail and pre-position it
- Guide timing belt through deflection
- Slide the deflection onto the end of the rail
- Pre-assemble fastening screws
- Attach timing belt to slide with hexagon socket wrench SW3 to tension the deflection
- Tighten fixing screws

Drill hole for drive shaft	Weight	Part no.	Part no. corrosion resistant design
without	0,96 kg	28.0510/0	28.0509/0
Ø 10 mm	0,96 kg	28.0510/1	28.0509/1
Ø 11 mm	0,96 kg	28.0510/2	28.0509/2
Ø 14 mm	0,96 kg	28.0510/3	28.0509/3

T 45 (LR 12 + LR 16)

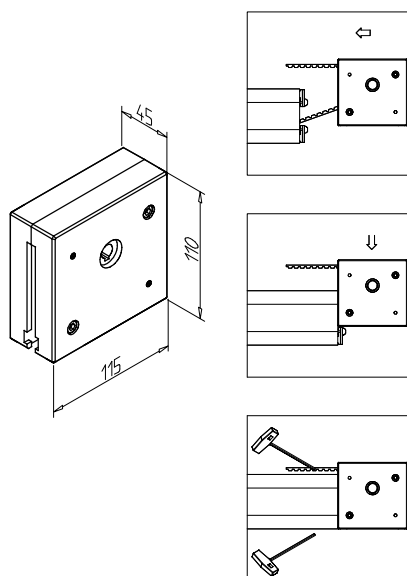

Technical Data/Items Supplied

- Anodized aluminum E6/EV1
- Body complete with pulley
- 2 Precision ball bearings

Application

- For MiniTec Linear Guides LR 12 & LR 16, freely combinable

Assembly

- Rail frontally provided at both ends with thread M8
- Power-lock Fastener Part no. 21.0818/0 screw in
- Guide timing belt through deflection
- Slide the deflector from above over the profile connector
- Tighten power-lock fastener
- Tighten timing belt
- For mounting use the corrosion resistant version power-lock fastener H Part no. 21.1018/1.

Drill hole for drive shaft	Weight	part no.	Part no. corrosion resistant design
without	1,170 kg	28.0614/0	28.0615/0
Ø 11 mm	1,168 kg	28.0614/2	28.0615/2
Ø 12 mm	1,168 kg	28.0614/6	28.0615/6
Ø 14 mm	1,167 kg	28.0614/3	28.0615/3
Ø 15 mm	1,165 kg	28.0614/5	28.0615/5
Ø 16 mm	1,165 kg	28.0614/4	28.0615/4

For the connection of motors and encoders we can produce special adapter plates suitable for the application. Please refer part no. 28.0112/0

TIMING BELT PULLEY

T 90 (LR 12 + LR 16)

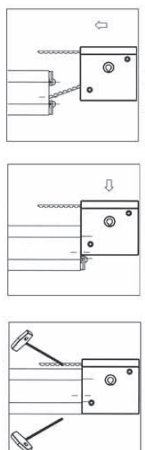
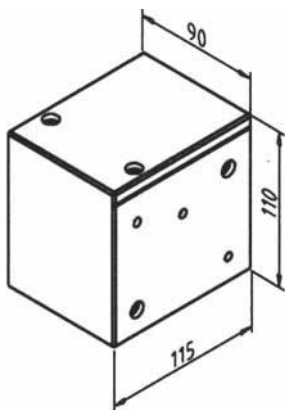

Technical Data/Items Supplied

- Anodized aluminum E6/EV1
- Body complete with pulley
- 2 Precision ball bearings
- top cover mounted

Application

- For MiniTec-linear guides LR 12, LR 16, LR 45 x 90 F, LR 90, LR 180,

Assembly

- Rail frontally provided at both ends with thread M8
- Power-lock Fastener Part no. 21.0818/0 screw in
- Guide timing belt through deflection
- Slide the deflector from above over the profile connector
- Tighten profile connectors
- Tighten timing belt
- For mounting use the corrosion resistant version power-lock fastener H Part no. 21.1018/1.

Drill hole for drive shaft	Weight	part no.	Part no. corrosion resistant design
without	2,800 kg	28.0082/0	28.0045/0
Ø 11 mm	2,798 kg	28.0082/2	28.0045/2
Ø 14 mm	2,795 kg	28.0082/3	28.0045/3
Ø 16 mm	2,789 kg	28.0082/4	28.0045/4
Ø 19 mm	2,775 kg	28.0082/5	28.0045/5
Ø 20 mm	2,773 kg	28.0082/7	28.0045/7
Ø 24 mm	2,164 kg	28.0082/6	28.0045/6

For the connection of motors and encoders we can produce special adapter plates suitable for the application. Please refer part no. 28.0112/0

TIMING BELT PULLEY T45 Z

Part no.

28.0614/1

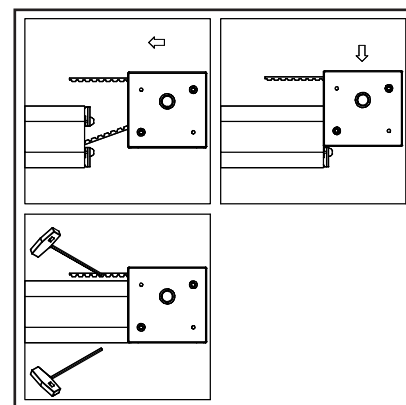
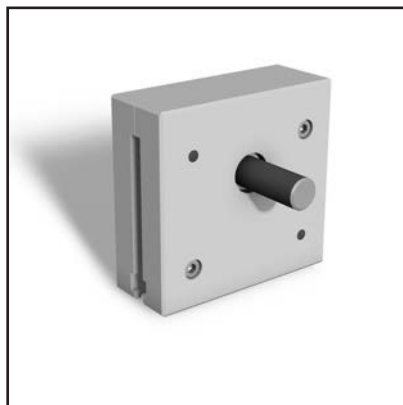
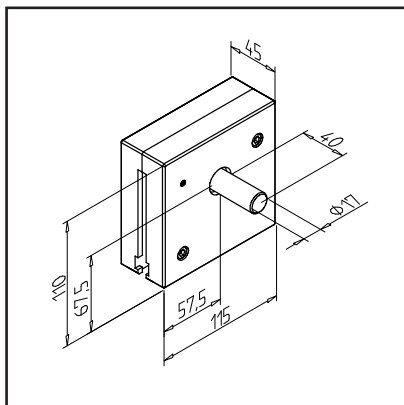
**TECHN. DATA / ITEMS SUPPLIED**

- Aluminium, anodized E6/EV1
- Base body complete with belt pulley and shaft stub
- 2 ball-bearings
- **Stainless version part no. 28.0615/1**
- Drive taps also available in different diameters, lengths and with keyways
- Weight = 1.369 kg/piece

APPLICATIONS

- All MiniTec linear guides

ASSEMBLY

- Provide rails with thread M8 at both sides, screw in Power lock fastener **part no. 21.1018/0**
- Guide the timing belt through the reverse unit
- Insert pulley unit from top
- Tighten power-lock fastener
- Tighten the timing belt
- For mounting the corrosion-resistant version, use profile connector H **part no.21.1018/1**

TIMING BELT REVERSE UNIT T 90 Z

Part no.

28.0082/1

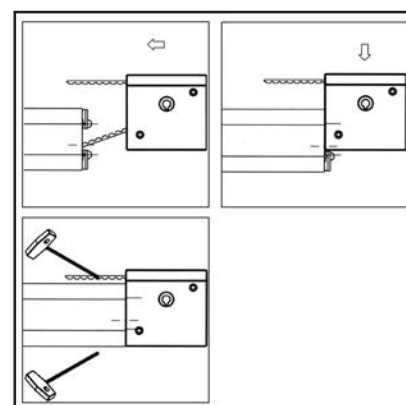
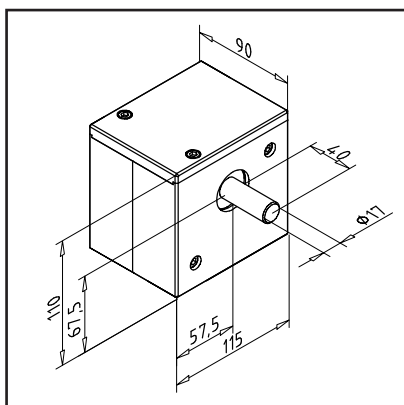
**TECHN. DATA / ITEMS SUPPLIED**

- Steel, anodized E6/EV1
- Base body complete with belt pulley and shaft stub
- 2 ball-bearings
- Top cover installed
- **Stainless version part no. 28.0045/1**
- Drive taps also available in different diameters, lengths and with keyways
- Weight = 2.850 kg/piece

APPLICATIONS

- All MiniTec linear guides

ASSEMBLY

- Provide rails with thread M8 at both sides, screw in Power lock fastener **part no. 21.1018/0**
- Guide the timing belt through the reverse unit
- Insert pulley unit from top
- Tighten power-lock fastener
- Tighten the timing belt
- For mounting the corrosion-resistant version, use profile connector H **part no.21.1018/1**

MINI-ADJUSTING UNIT MOUNTING KIT

Part no. 28.0350/0

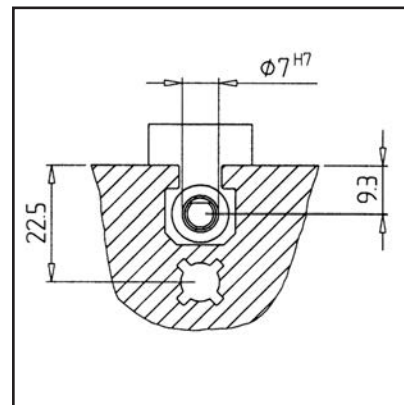
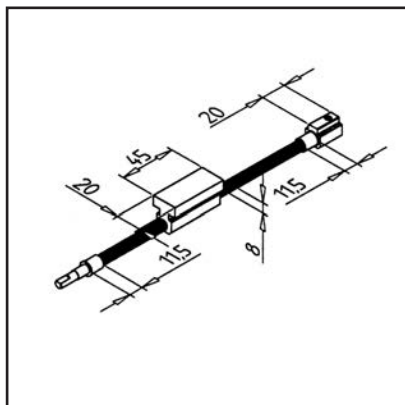

TECHN. DATA / ITEMS SUPPLIED

- Without carrier profile, handwheel and bearing block for mounting into existing equipment
- VA spindle M8 x 1.25
- Brass slide
- Max. load 1 - 2 kg
- **Please indicate desired length of stroke**

APPLICATIONS

- For adjustment of the lateral guides on conveying equipment
- For adjusting sensor holders or light barriers
- For simple equipment

ASSEMBLY

- Make bearing block according to sketch
- Push into the profile groove and fasten the end block

MINI-ADJUSTING UNIT WITH PROFILE 45X45

Part no. 28.0354/0

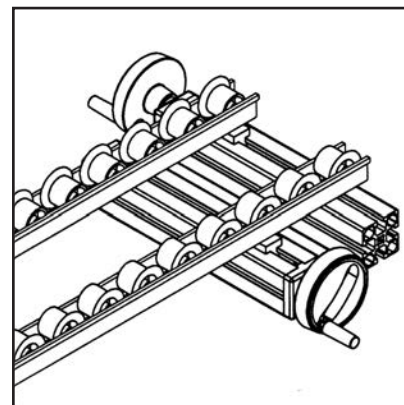
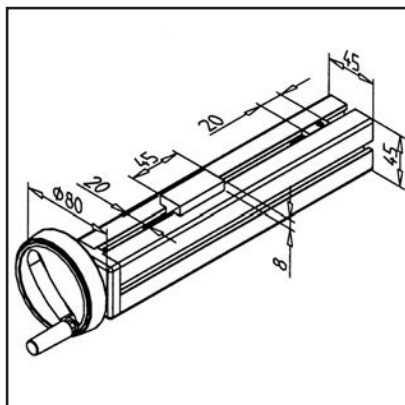

TECHN. DATA / ITEMS SUPPLIED

- With carrier profile 45 x 45 F
- VA spindle M8 x 1.25
- Brass slide
- Max. load 1 - 2 kg
- **Please indicate desired length of stroke**

APPLICATIONS

- For adjustment of the lateral guides on conveying equipment
- For adjusting sensor holders or light barriers
- For simple equipment

ASSEMBLY

- With MiniTec power-lock fastener
- Can also be fastened with a mounting bracket
- Also available without carrier profile, **part no. 28.0354/1**

MINI-ADJUSTING UNIT WITH PROFILE 19X45

Part no.

28.0352/0

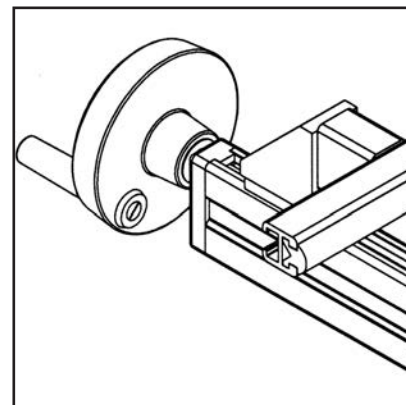
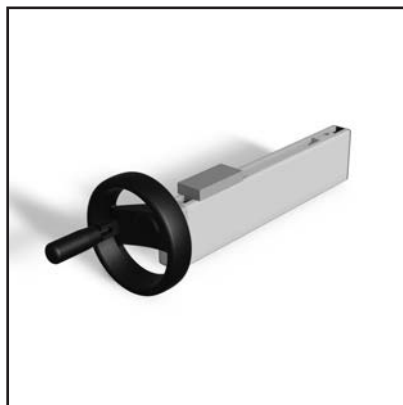
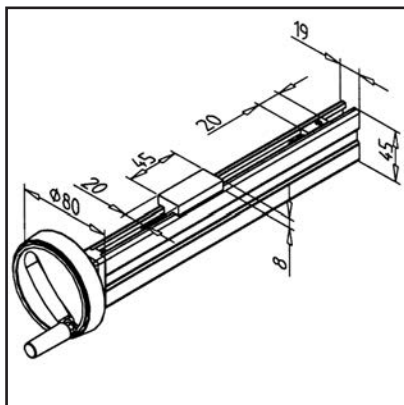
**TECHN. DATA / ITEMS SUPPLIED**

- With carrier profile 19 x 45
- VA spindle M8 x 1.25
- Brass slide
- Max. load 1 - 2 kg
- **Please indicate desired length of stroke**

APPLICATIONS

- For adjustment of the lateral guides on conveying equipment
- For adjusting sensor holders or light barriers
- For simple equipment

ASSEMBLY

- With MiniTec power-lock fastener
- Can also be fastened with a mounting bracket
- Also available without carrier profile, **part no. 28.0352/1**

MINI ADJUSTING UNIT WITH PROFILE 45X19

Part no.

28.0359/0

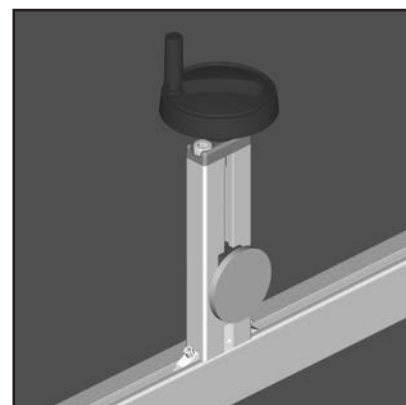
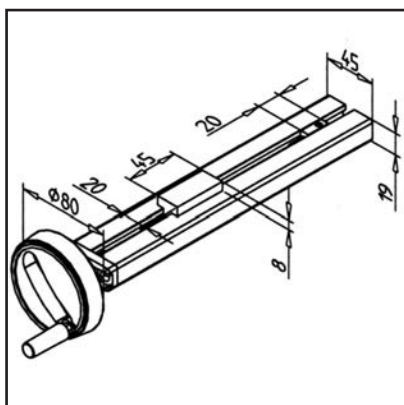
**TECHN. DATA / ITEMS SUPPLIED**

- With carrier profile 19 x 45
- VA spindle M8 x 1.25
- Brass slide
- Max. load 1 - 2 kg
- **Please indicate desired length of stroke**

APPLICATIONS

- For adjustment of the lateral guides on conveying equipment
- For adjusting sensor holders or light barriers
- For simple equipment

ASSEMBLY

- With MiniTec power-lock fastener
- Can also be fastened with a mounting bracket
- Also available without carrier profile, **part no. 28.0359/1**

MINI-ADJUSTING UNIT WITH PROFILE 19X32

Part no. 28.0351/0

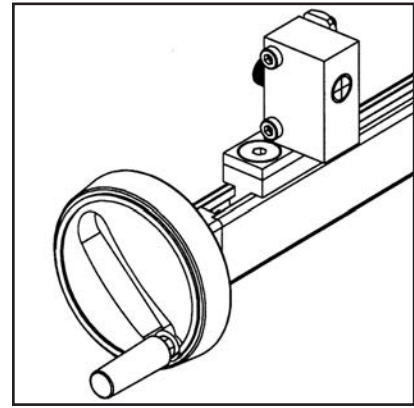
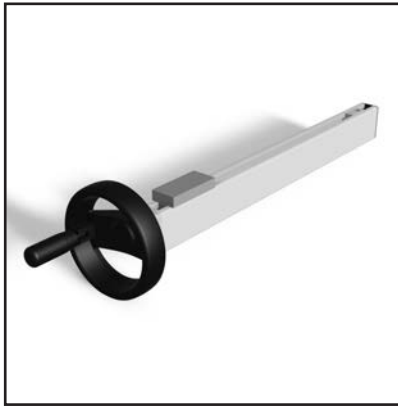
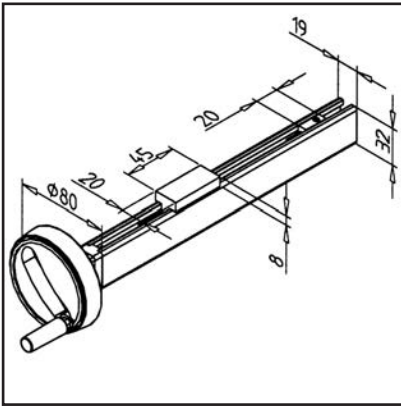

TECHN. DATA / ITEMS SUPPLIED

- With carrier profile 19 x 32
- VA spindle M8 x 1.25
- Brass slide
- Max. load 1 - 2 kg
- **Please indicate desired length of stroke**

APPLICATIONS

- For adjustment of the lateral guides on conveying equipment
- For adjusting sensor holders or light barriers
- For simple equipment

ASSEMBLY

- With MiniTec power-lock fastener
- Can also be fastened with a mounting bracket
- Also available without carrier profile, **part no. 28.0351/1**

MINI-ADJUSTING UNIT WITH HANDLE PROFILE 32

Part no. 28.0353/0

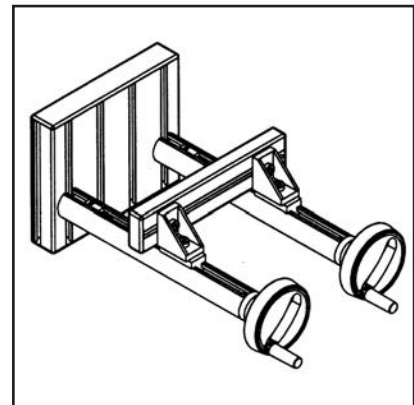
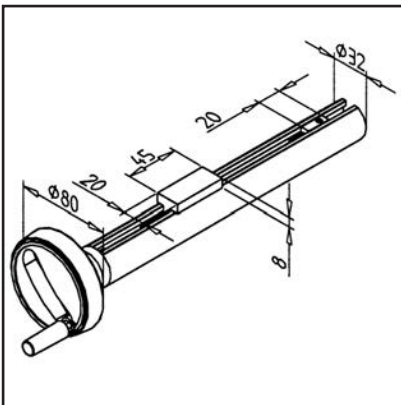

TECHN. DATA / ITEMS SUPPLIED

- With carrier profile handle profile 32
- VA spindle M8 x 1.25
- Brass slide
- Max. load 1 - 2 kg
- **Please indicate desired length of stroke**

APPLICATIONS

- For adjustment of the lateral guides on conveying equipment
- For adjusting sensor holders or light barriers
- For simple equipment

ASSEMBLY

- With MiniTec power-lock fastener
- Can also be fastened with a mounting bracket
- Fasten handle profile 32 with clip, **part no. 22.1022/0**
- Also available without carrier profile, **part no. 28.0353/1**

ANGLE CONSOLE FOR MINI-ADJUSTING UNIT

Part no.

28.0371/0

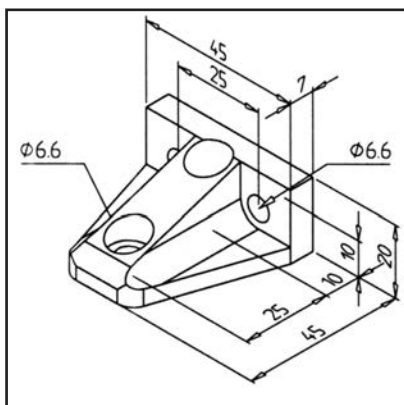

TECHN. DATA / ITEMS SUPPLIED

- Aluminium, anodized E6/EV1
- Without fastening kit
- Weight = 0.044 kg/piece



APPLICATIONS

- For connection of two adjustment units
part no. 28.0351/0, 28.0352/0 and 28.0353/0
- For adjusting small loads such as light barriers, sensors, etc.

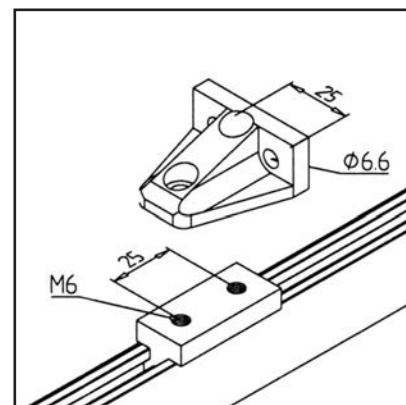

ASSEMBLY

- Insert two M6 threads each, 10 mm deep with a clearance of 25 mm in the slide
- With cylinder head bolts M6 x 16 **part no. 21.1238/0** Connect adjustment units together

ADJUSTING UNIT VIEW 90

Part no. 28.0183/0

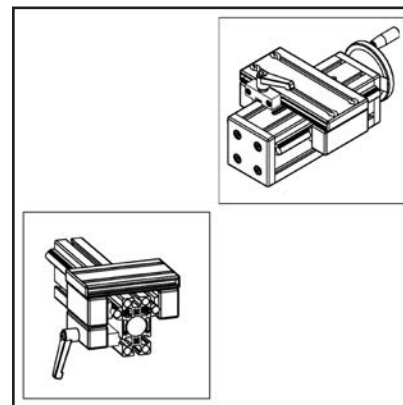
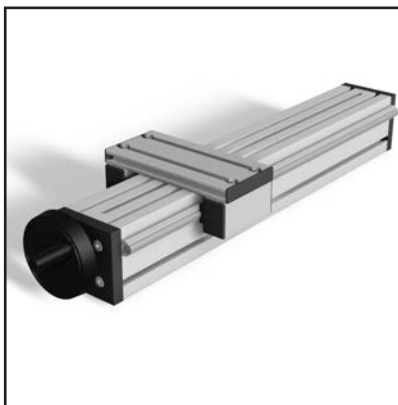
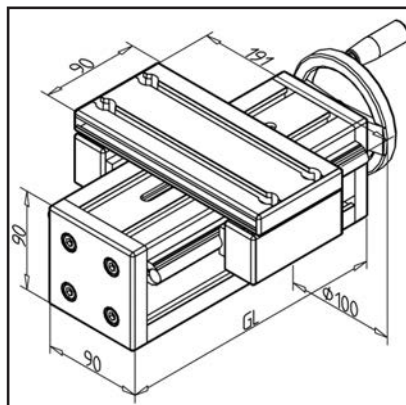

TECHN. DATA / ITEMS SUPPLIED

APPLICATIONS

OTHER VERSIONS

- Aluminium, anodized E6/EV1
- Slide plate of profile 19 x 90
- Spindle 16 x 4
- Basic length (GL) 120 mm (0 mm stroke)
- **Please indicate desired length of stroke**
- Weight = (basic weight) 3.03 kg
- Extra weight = 1.12 kg/100mm stroke

- Adjustment of conveyors
- Adjustment of feeders
- Adjustable devices

- Slide plate made of profile 32 x 180
- Deviating wagon length
- Digital display
- Angular drive
- Spindle cover
- Shafts stainless
- Options:
With carriage clamp up **part no. 28.0183/1**
With carriage clamping laterally **part no. 28.0183/2**

ADJUSTING UNIT VIEW 45X90 F

Part no. 28.0181/0

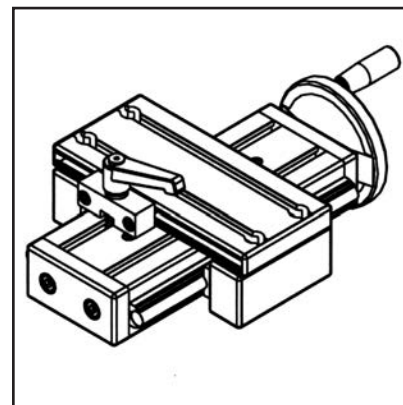
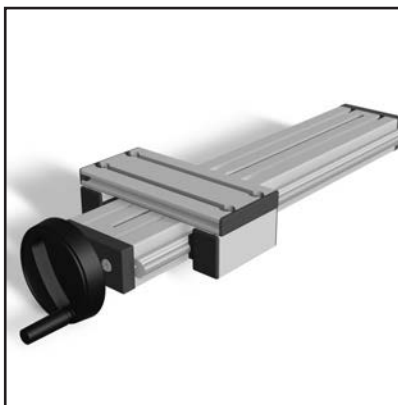
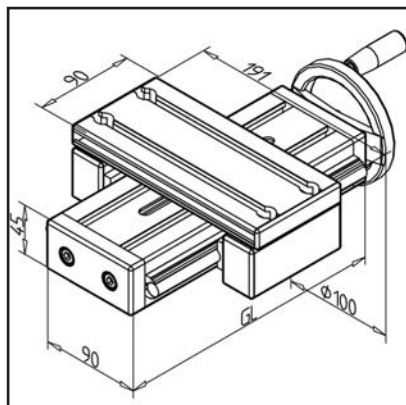

TECHN. DATA / ITEMS SUPPLIED

APPLICATIONS

OTHER VERSIONS

- Aluminium, anodized E6/EV1
- Slide plate of profile 19 x 90
- Spindle 16 x 4
- Basic length (GL) 120 mm (0 mm stroke)
- **Please indicate desired length of stroke**
- Weight = (basic weight) 2.31 kg
- Extra weight = 0.75 kg/100mm stroke

- Adjustment of conveyors
- Adjustment of feeders
- Adjustable devices

- Slide plate made of profile 32 x 180
- Deviating wagon length
- Digital display
- Angular drive
- Spindle cover
- Shafts stainless
- OPTIONS: With slide clamping device at top **part no. 28.0181/1**

ADJUSTING UNIT VEW 45X90 H

Part no.

28.0182/0

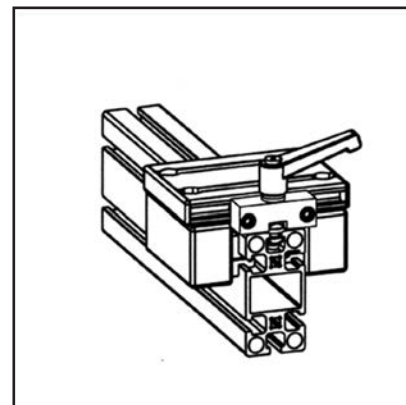
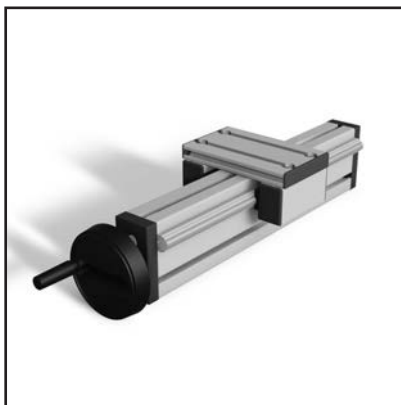
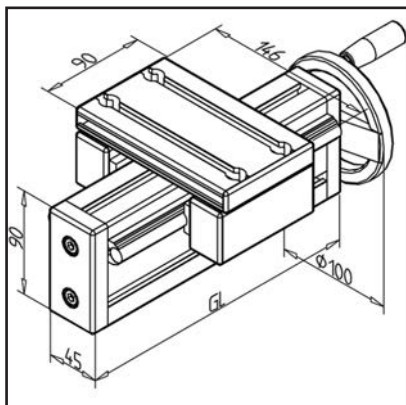
**TECHN. DATA / ITEMS SUPPLIED**

- Aluminium, anodized E6/EV1
- Slide plate of profile 19 x 90
- Spindle 16 x 4
- Basic length (GL) 120 mm (0 mm stroke)
- **Please indicate desired length of stroke**
- Weight = (basic weight) 2.109 kg
- Extra weight = 0.74 kg/100mm stroke

APPLICATIONS

- Adjustment of conveyors
- Adjustment of feeders
- Adjustable devices

OTHER VERSIONS

- Slide plate made of profile 32 x 180
- Deviating wagon length
- Digital display
- Angular drive
- Shafts stainless
- Options:
With carriage clamp up **part no. 28.0182/1**
With clamping laterally **part no. 28.0182/2**

ADJUSTING UNIT VEN 45X90S

Part no.

28.0187/0

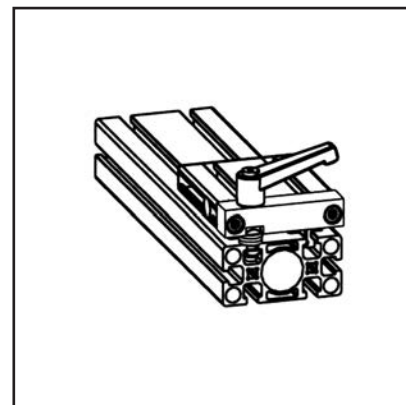
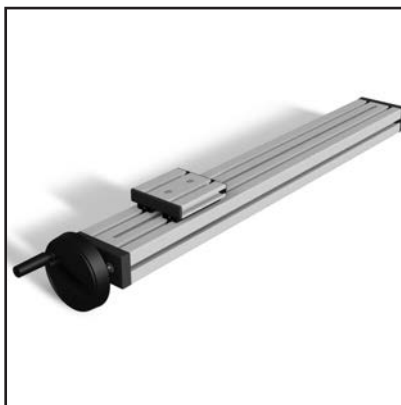
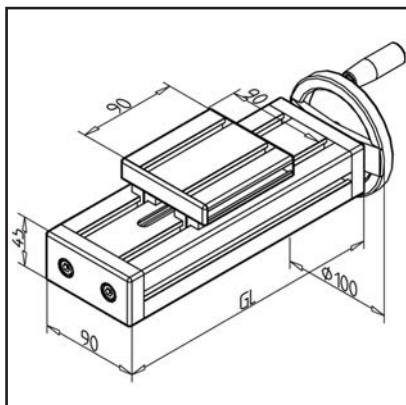
**TECHN. DATA / ITEMS SUPPLIED**

- Aluminium, anodized E6/EV1
- Slide plate of profile 19 x 90
- Spindle 16 x 4
- Basic length (GL) 120 mm (0 mm stroke)
- **Please indicate desired length of stroke**
- Weight = (basic weight) 2.280 kg
- Extra weight = 0.5 kg/100mm stroke

APPLICATIONS

- Adjustment of conveyors
- Adjustment of feeders
- Adjustable devices

OTHER VERSIONS

- Slide plate made of profile 32 x 180
- Deviating wagon length
- Digital display
- Angular drive
- Options:
With slide clamping unit (Top) **part no. 28.0187/1**

ADJUSTING UNIT VEN 90

Part no. 28.0186/0

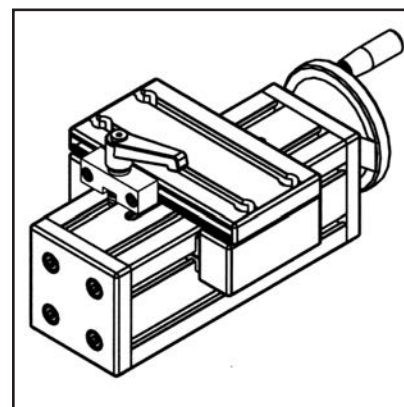
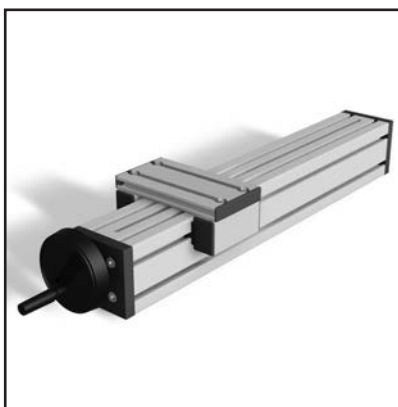
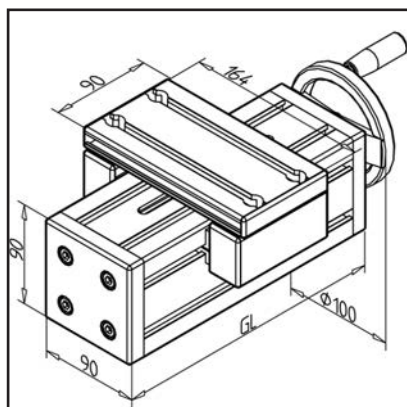

TECHN. DATA / ITEMS SUPPLIED

APPLICATIONS

OTHER VERSIONS

- Aluminium, anodized E6/EV1
- Slide plate of profile 19 x 90
- Spindle 16 x 4
- Basic length (GL) 120 mm (0 mm stroke)
- **Please indicate desired length of stroke**
- Weight = (basic weight) 2.75 kg
- Extra weight = 0.87 kg/100mm stroke

- Adjustment of conveyors
- Adjustment of feeders
- Adjustable devices

- Slide plate made of profile 32 x 180
- Deviating wagon length
- Digital display
- Angular drive
- Spindle cover
- Options:
- With carriage clamp up **part no. 28.0186/1**
- With carriage clamping laterally **part no. 28.0186/2**

ADJUSTING UNIT VEN 45X90

Part no. 28.0188/0

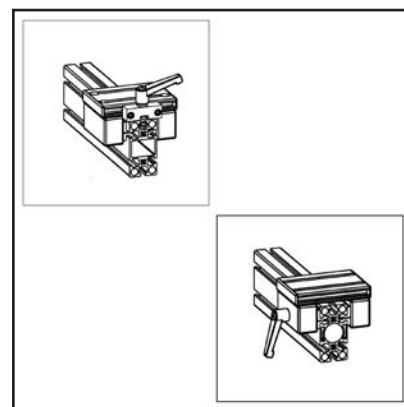
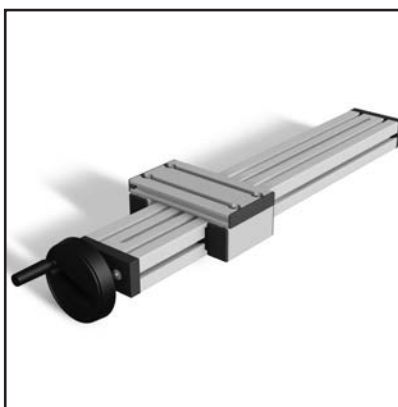
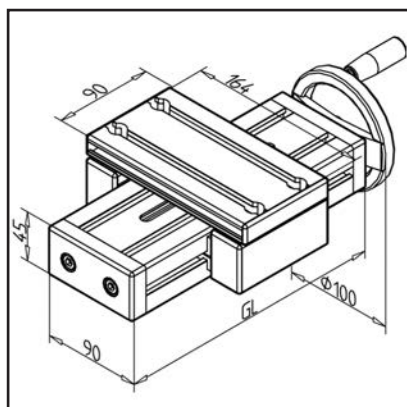

TECHN. DATA / ITEMS SUPPLIED

APPLICATIONS

OTHER VERSIONS

- Aluminium, anodized E6/EV1
- Slide plate of profile 19 x 90
- Spindle 16 x 4
- Basic length (GL) 120 mm (0 mm stroke)
- **Please indicate desired length of stroke**
- Weight = (basic weight) 2.05 kg
- Extra weight = 0.5 kg/100mm stroke

- Adjustment of conveyors
- Adjustment of feeders
- Adjustable devices

- Slide plate made of profile 32 x 180
- Deviating wagon length
- Digital display
- Angular drive
- Spindle cover
- Options:
- With carriage clamp up **part no. 28.0188/1**
- With carriage clamping laterally **part no. 28.0188/2**

ADJUSTING UNIT VEN 45X90 H

Part no.

28.0185/0

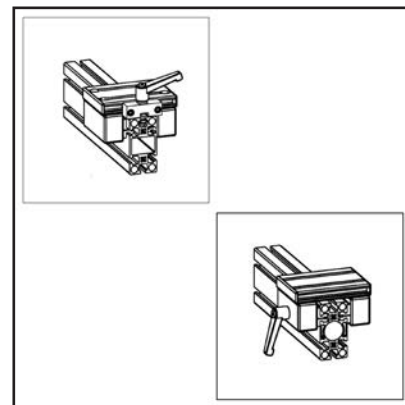
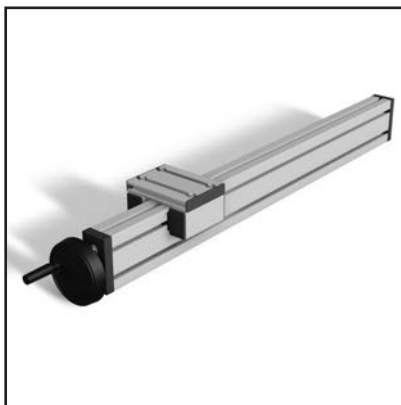
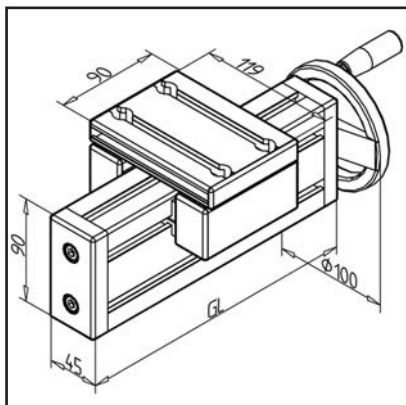
**TECHN. DATA / ITEMS SUPPLIED**

- Aluminium, anodized E6/EV1
- Slide plate of profile 19 x 90
- Spindle 16 x 4
- Basic length (GL) 120 mm (0 mm stroke)
- **Please indicate desired length of stroke**
- Weight = (basic weight) 1.97 kg
- Extra weight = 0.49 kg/100mm stroke

APPLICATIONS

- Adjustment of conveyors
- Adjustment of feeders
- Adjustable devices

OTHER VERSIONS

- Slide plate made of profile 32 x 180
- Deviating wagon length
- Digital display
- Angular drive
- Options:
 - With carriage clamp up **part no. 28.0185/1**
 - With carriage clamping laterally **part no. 28.0185/2**

SLIDING GUIDES

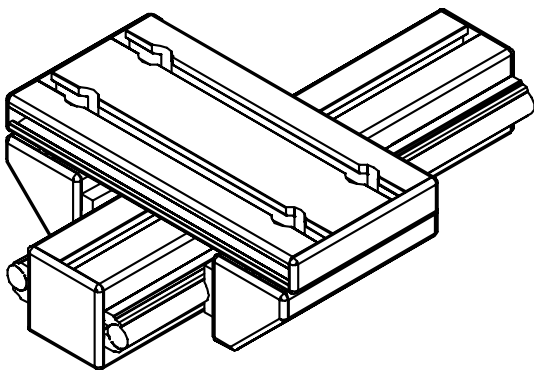
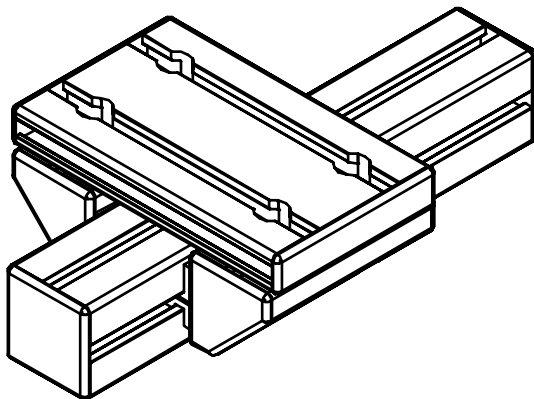
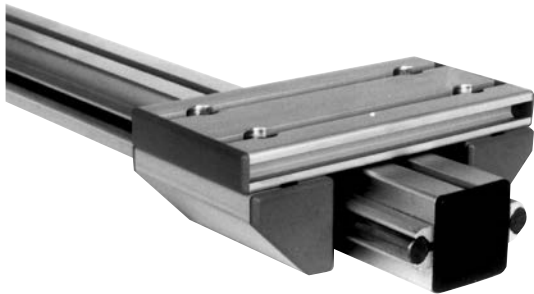

The sliding guides LN / LG were created for applications that do not place high demands on guidance accuracy, but in which extreme operating conditions prevail. Especially for wet operation, high dust or lack of lubrication, these guides are suitable. The carriages of the series LN / LG are built on the same modular principle as the linear series LR.

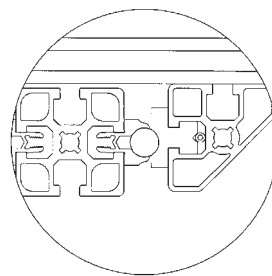
**Series LN**

Guide the carriages in profile groove or profile surface. This series is characterized by a small installation space.

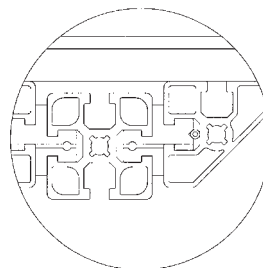
**Series LG**

Guiding of carriages on ground and hardened shafts h6 made of material Cf53. Particularly advantageous is the use of guides LG in wet operation in conjunction with our stainless shafts.

Precision

$\pm 0,15$ mm (Series LG) and $\pm 0,20$ mm (Series LN). The guides can be adjusted without play by providing the lateral guide rails.

Permitted loads

50 N/cm carrying sliding strip (= carriage length)

Sliding friction

0,05 on steel shaft (LG series) 0.1 on anodized profile surface (LN series)

This storage can be operated without lubrication. An increased slip-stick effect has to be considered.

Traversing

1 m/sec (max.)

Continuous temperature

50°C (max.)

Short-term peak load

70°C (max.)

The sliding strip is resistant to organic acids, alkalis, aqueous solutions, inorganic salts, organic acids and alcohols. Against hydrocarbons and halogenated hydrocarbons, the material is only partially resistant.

SLIDE G 32

Part no.

28.0355/0

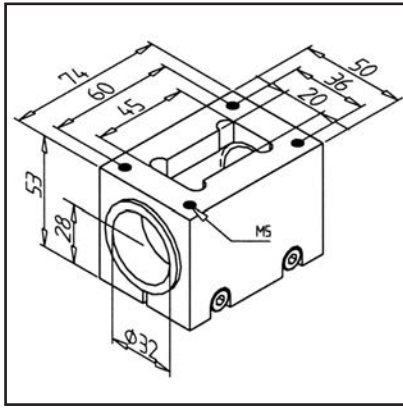
**TECHN. DATA / ITEMS SUPPLIED**

- Aluminium, anodized E6/EV1
- With low-friction sliding bearing
- Without adjusting units
- Weight = 0.314 kg/piece

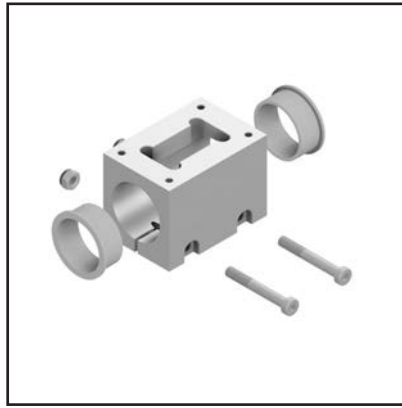
**APPLICATIONS**

- To adjust light barriers, reflectors, lateral guides etc.

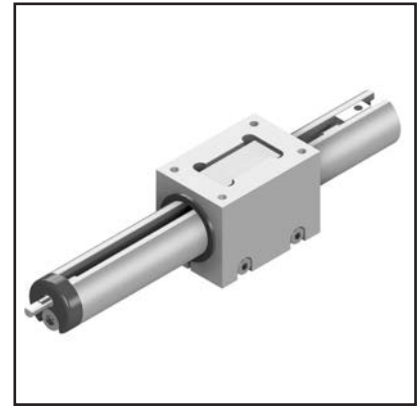
**ASSEMBLY**

- Insert slide of mini-adjustment unit into sliding carriage and screw in the spindle
- Adjust with tensioning screws M6
- Fasten the spindle bearing to the handle profile 32

SLIDE LWN-S

Part no.

28.0170/0

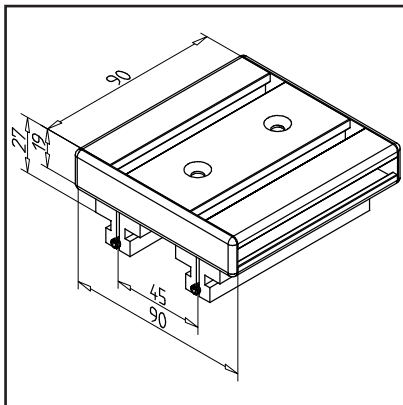
**TECHN. DATA / ITEMS SUPPLIED**

- Aluminium, anodized E6/EV1
- Fully mounted carriage
- 2 slide rails LN-S
- End caps
- Clearance adjusted
- load capacity up to 450 N
- Weight = 0.260 kg/piece

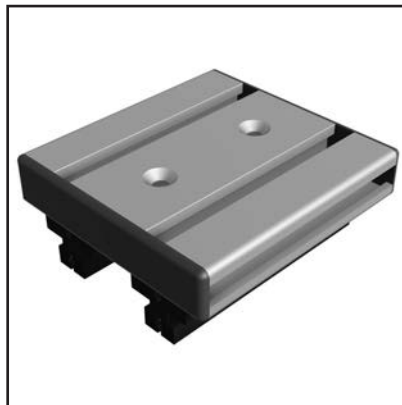
**APPLICATIONS**

- Simple linear guides
- Slide units

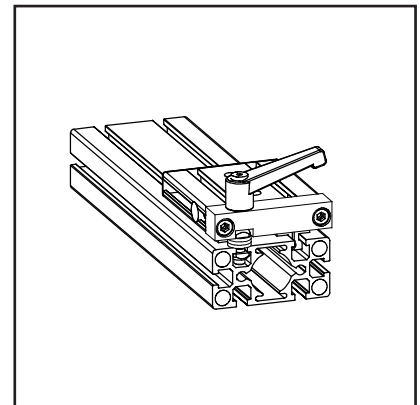
**OTHER VERSIONS**

- With slide clamping device at top **part no. 28.0170/1**
- Slide plate made of profile 32 x 180
- Different slide lengths

SLIDE LWN 45/45° - 90

Part no. 28.0197/0

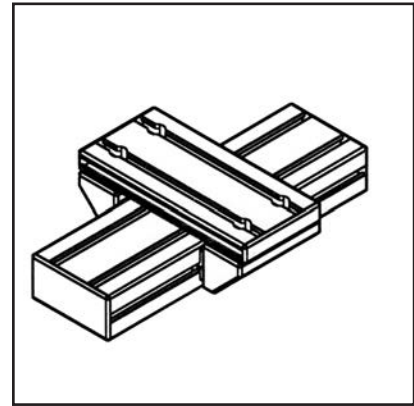
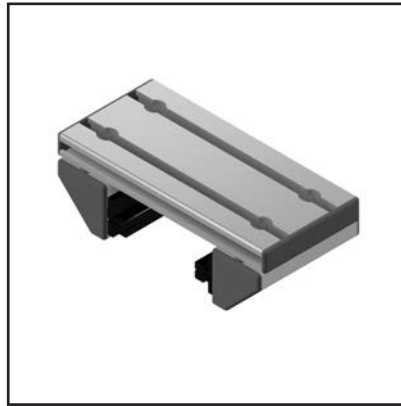
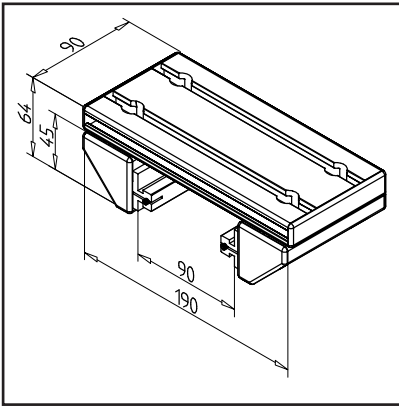

TECHN. DATA / ITEMS SUPPLIED

- Aluminium, anodized E6/EV1
- Fully mounted carriage
- 2 slide rails LN
- End caps
- Clearance adjusted
- load capacity up to 450 N
- Weight = 0.783 kg/piece

APPLICATIONS

- Simple linear guides
- Slide units

OTHER VERSIONS

- With slide clamping device at top **part no. 28.0197/1**
- Slide plate made of profile 32 x 180
- Different slide lengths

SLIDE LWN 45/45° - 45

Part no. 28.0196/0

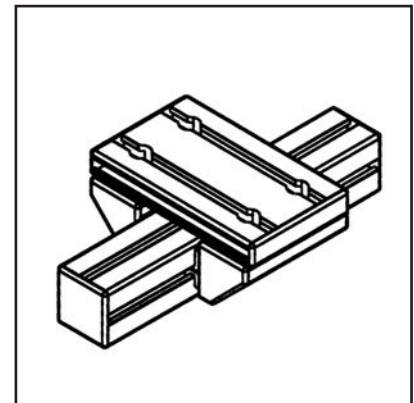
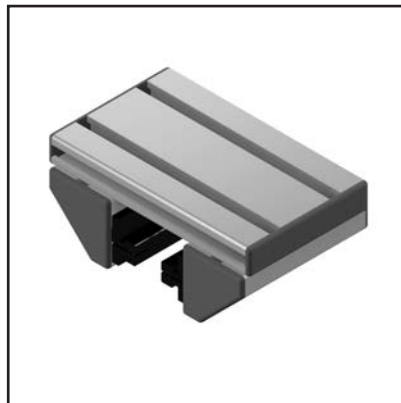
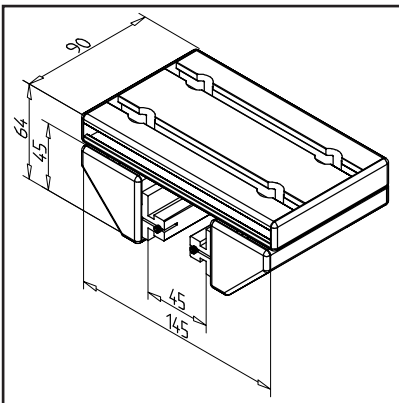

TECHN. DATA / ITEMS SUPPLIED

- Aluminium, anodized E6/EV1
- Fully mounted carriage
- 2 slide rails LN
- End caps
- Clearance adjusted
- load capacity up to 450 N
- Weight = 0.699 kg/piece

APPLICATIONS

- Simple linear guides
- Slide units

OTHER VERSIONS

- With slide clamping device at top **part no. 28.0196/1**
- Slide plate made of profile 32 x 180
- Different slide lengths

SLIDE LWN 32 X 45 - 90

Part no.

28.0193/0

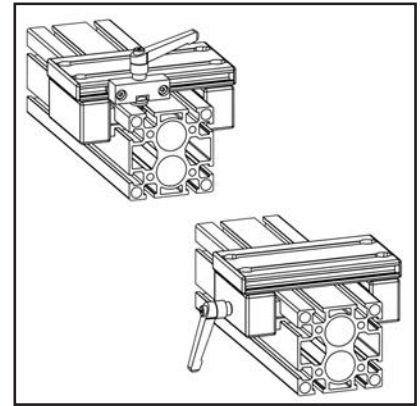
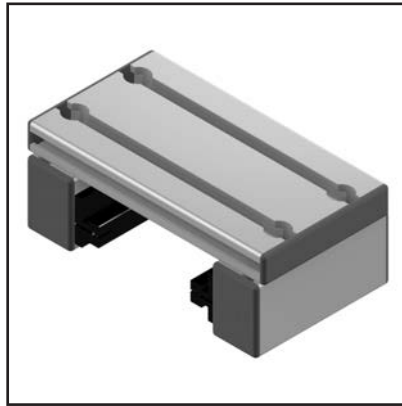
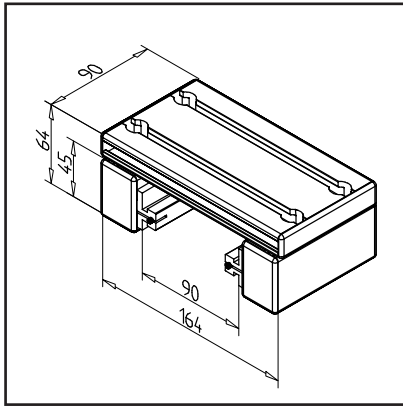
**TECHN. DATA / ITEMS SUPPLIED**

- Aluminium, anodized E6/EV1
- Fully mounted carriage
- 2 slide rails LN
- End caps
- Clearance adjusted
- load capacity up to 450 N
- Weight = 0.762 kg/piece

APPLICATIONS

- Simple linear guides
- Slide units

OTHER VERSIONS

- With slide clamping device at top **part no. 28.0193/1**
- With slide clamping device lateral **part no. 28.0193/2**
- Slide plate made of profile 32 x 180
- Different slide lengths

SLIDE LWN 32 X 45 - 45

Part no.

28.0192/0

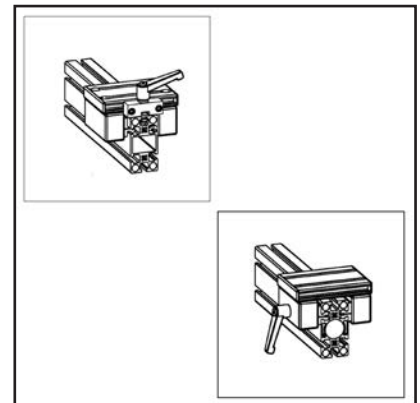
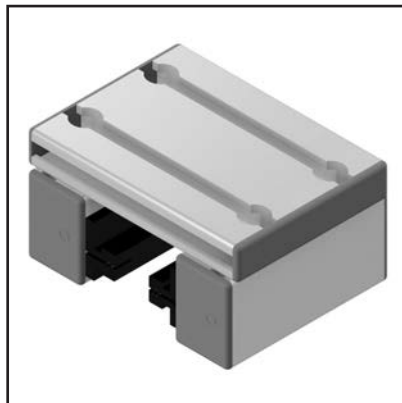
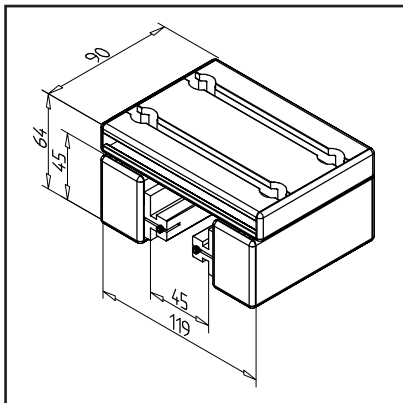
**TECHN. DATA / ITEMS SUPPLIED**

- Aluminium, anodized E6/EV1
- Fully mounted carriage
- 2 slide rails LN
- End caps
- Clearance adjusted
- load capacity up to 450 N
- Weight = 0.678 kg/piece

APPLICATIONS

- Simple linear guides
- Slide units

OTHER VERSIONS

- With slide clamping device at top **part no. 28.0192/1**
- With slide clamping device lateral **part no. 28.0192/2**
- Slide plate made of profile 32 x 180
- Different slide lengths

SLIDE LWG 45/45°-90

Part no. 28.0137/0

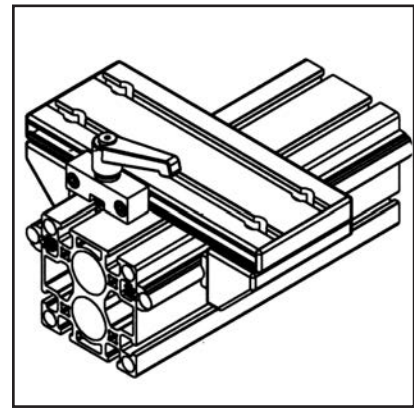
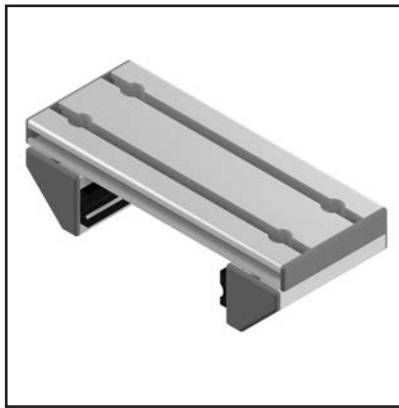
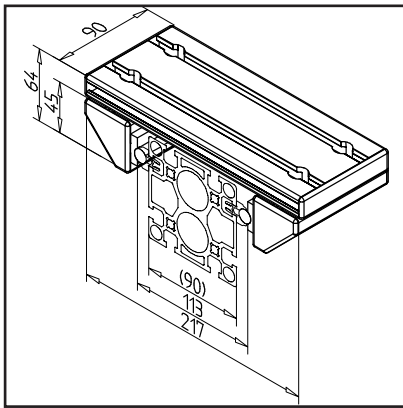

TECHN. DATA / ITEMS SUPPLIED

- Aluminium, anodized E6/EV1
- Fully mounted carriage
- 2 slide rails LG
- End caps
- Clearance adjusted
- load capacity up to 450 N
- Weight = 0.831 kg/piece

APPLICATIONS

- Simple linear guides
- Slide units
- For rail 90 with shafts Ø 12 mm

OTHER VERSIONS

- With slide clamping at top **part no. 28.0137/1**
- Slide plate made of profile 32 x 180
- Different slide lengths

SLIDE LWG 45/45° - 45

Part no. 28.0136/0

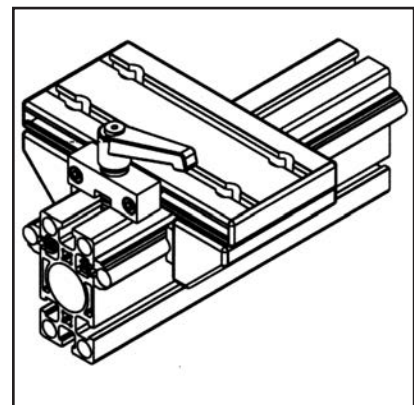
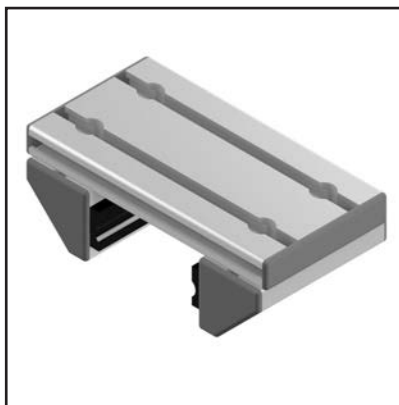
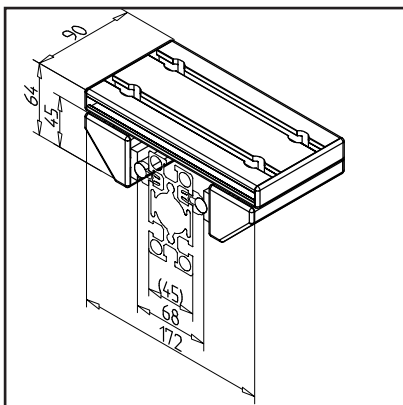

TECHN. DATA / ITEMS SUPPLIED

- Aluminium, anodized E6/EV1
- Fully mounted carriage
- 2 slide rails LG
- End caps
- Clearance adjusted
- load capacity up to 450 N
- Weight = 0.741 kg/piece

APPLICATIONS

- Simple linear guides
- Slide units
- For rail 45 with shafts Ø 12 mm

OTHER VERSIONS

- With slide clamping at top **part no. 28.0136/1**
- Slide plate made of profile 32 x 180
- Different slide lengths

SLIDE LWG 32 X 45 - 90

Part no.

28.0133/0

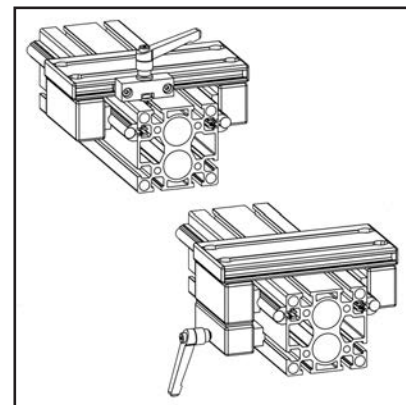
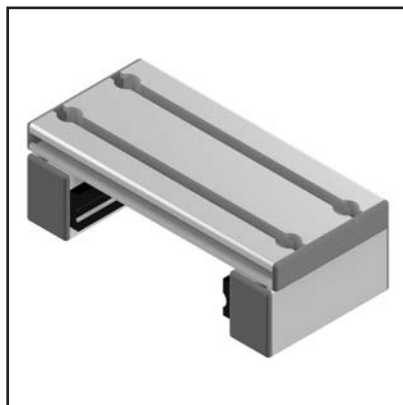
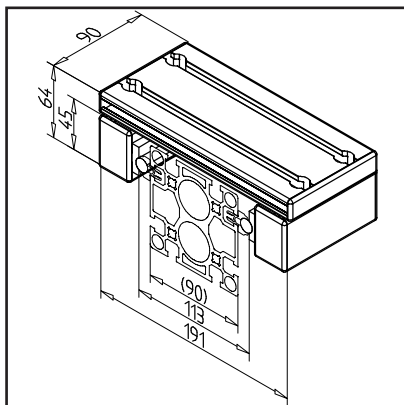
**TECHN. DATA / ITEMS SUPPLIED**

- Aluminium, anodized E6/EV1
- Fully mounted carriage
- 2 slide rails LG
- End caps
- Clearance adjusted
- load capacity up to 450 N
- Weight = 0.810 kg/piece

APPLICATIONS

- Simple linear guides
- Slide units
- For rail 90 with shafts \varnothing 12 mm

OTHER VERSIONS

- With slide clamping at top **part no. 28.0133/1**
- With slide clamping lateral **part no. 28.0133/2**
- Slide plate made of profile 32 x 180
- Different slide lengths

SLIDE LWG 32 X 45 - 45

Part no.

28.0132/0

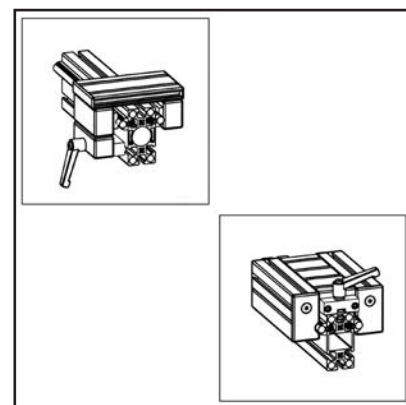
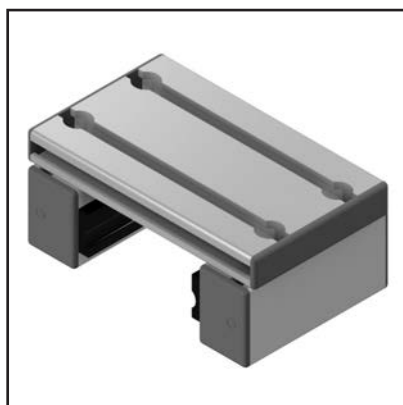
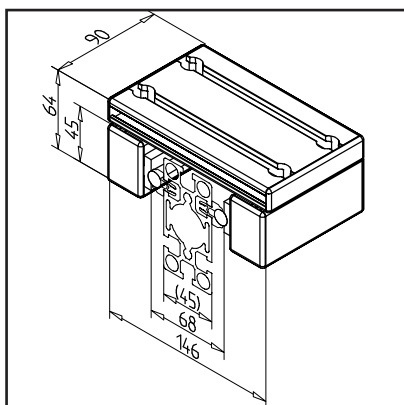
**TECHN. DATA / ITEMS SUPPLIED**

- Aluminium, anodized E6/EV1
- Fully mounted carriage
- 2 slide rails LG
- End caps
- Clearance adjusted
- load capacity up to 450 N
- Weight = 0.726 kg/piece

APPLICATIONS

- Simple linear guides
- Slide units
- For rail 45 with shafts \varnothing 12 mm

OTHER VERSIONS

- With slide clamping at top **part no. 28.0132/1**
- With slide clamping lateral **part no. 28.0132/2**
- Slide plate made of profile 32 x 180
- Different slide lengths

SLIDE RAIL LG

Part no.

22.1094/0

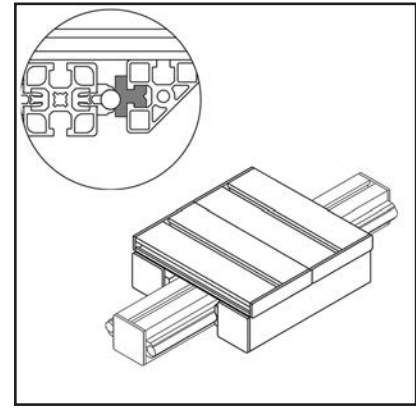
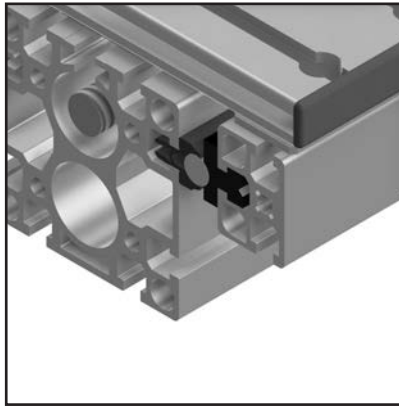
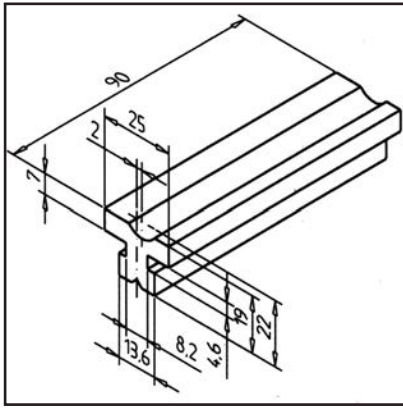

TECHN. DATA / ITEMS SUPPLIED

- PE-UHMW, black
- Fastening kit
- Allowed panel pressure: max. 10 N/mm²
- Weight = 0.029 kg/piece

APPLICATIONS

- Slide guides LG

ASSEMBLY

- Insert into groove of lateral guide profile
- Secure with fastening material

SLIDE RAIL LN

Part no.

22.1095/0

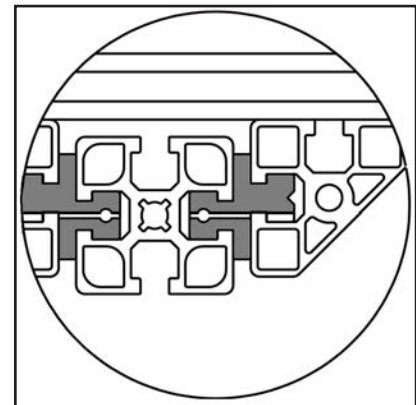
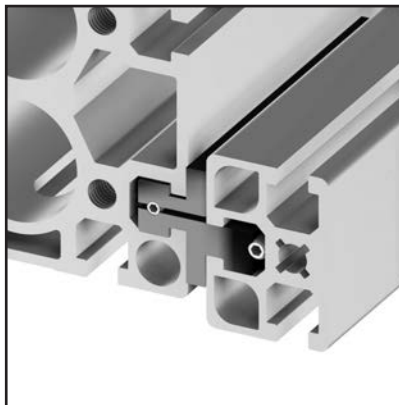
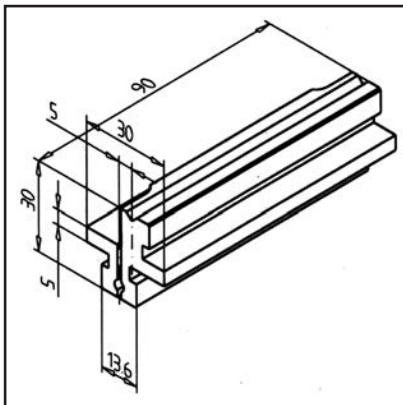

TECHN. DATA / ITEMS SUPPLIED

- PE-UHMW, black
- Fastening kit
- Allowed panel pressure: max. 10 N/mm²
- Weight = 0.030 kg/piece

APPLICATIONS

- Slide guides LN
- Adjusting units
- Heavy sliding doors
- Drawers

ASSEMBLY

- Connect with slide plate
- Insert into grooves of the guide profile
- Adjust without clearance, use fastening kit

SLIDE RAIL LN-S

Part no.

22.1096/0

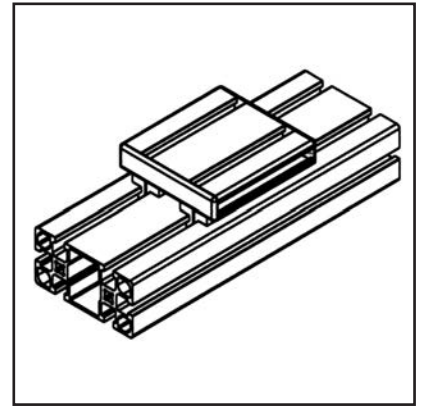
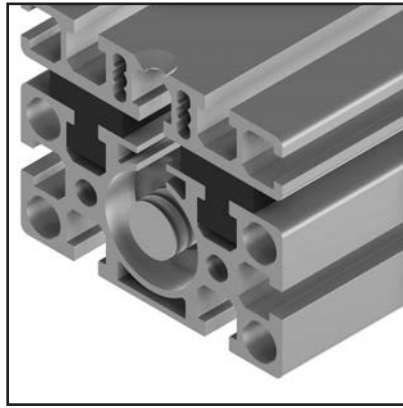
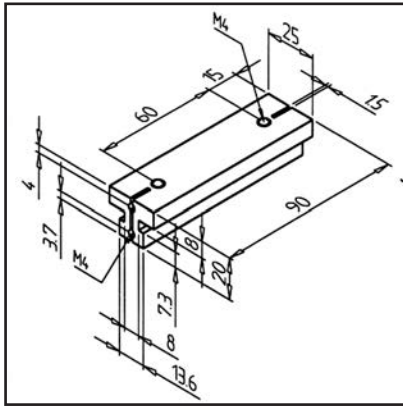
**TECHN. DATA / ITEMS SUPPLIED**

- PE-UHMW, black
- Fastening kit
- Allowed panel pressure: max. 10 N/mm²
- Weight = 0.036 kg/piece

APPLICATIONS

- Slide guides LN-S
- Adjusting units
- Slide units
- Workpiece carrier

ASSEMBLY

- Insert into grooves of the guide profile
- Adjust sliding rails without play
- Connect with slide plate

LINEAR SYSTEM LB



The LB guide is based on LME 20 linear ball bearings, which are incorporated in specially designed holes in our design profiles. Precision shafts D 20 mm give this guide high load capacity. Especially with short travel distances and high stroke frequency, the guide LB has significant advantages. Extremely compact and economical guide elements based on our LME series of precision ball bearings with integrated sealing rings, which underlie rough operating conditions ensure high functional reliability.

Calculation of the service life

$$L = \frac{C}{F} \cdot 10^5$$

L = Lifetime
 C = dyn. Load rating
 F = resulting external forces

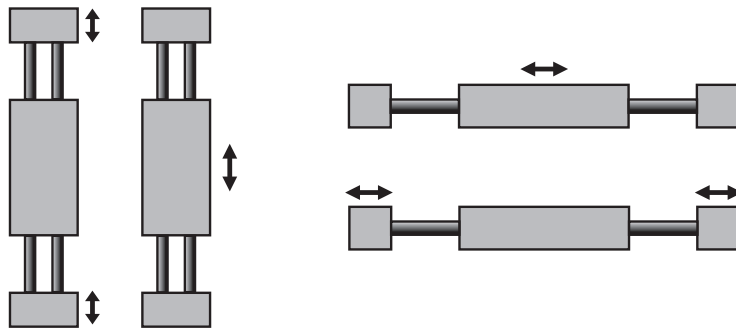

The MiniTec guides of the LB series are particularly suitable for strokes up to 1000 mm. The modular design gives the designer complete design freedom in a small footprint. The ball bushings with solid outer sheath made of hardened ball bearing steel are directly mounted in the holes Ø 32 mm of the specially designed construction profiles 45 x 135, 45 x 180, 90 x 180, 90 x 45 S and 90 x 90 S.

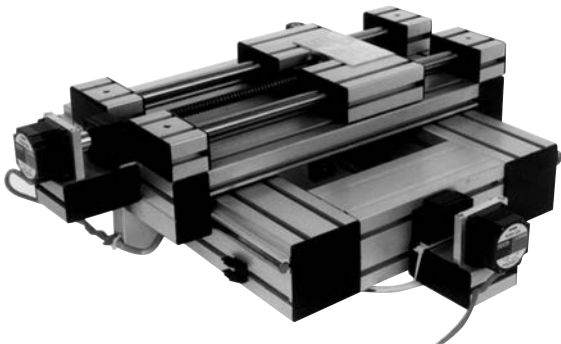

The axial securing takes place with one-component housing adhesive. The solid ball bushes ensure extreme ease of movement, play-free guidance and low noise with a long service life. When designing LB guide systems, it must be ensured that the shaft deflection does not exceed 0.5 ° due to the load.

Further Technical Data can be found in the MiniTec linear catalog. We also offer the linear guide LB complete with threaded or ball screw. All components are also available in stainless version.

LINEAR MODULE LB 90

Part no.

28.0178/0

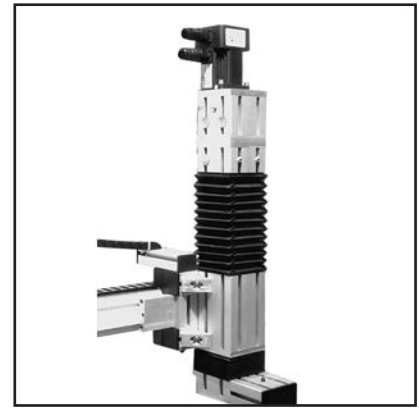
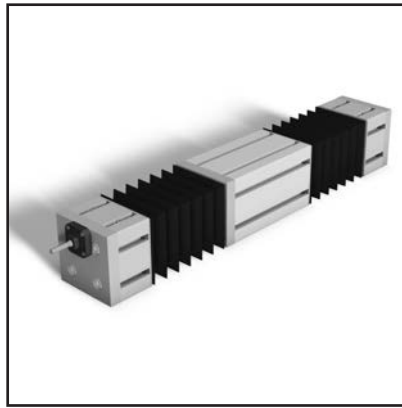
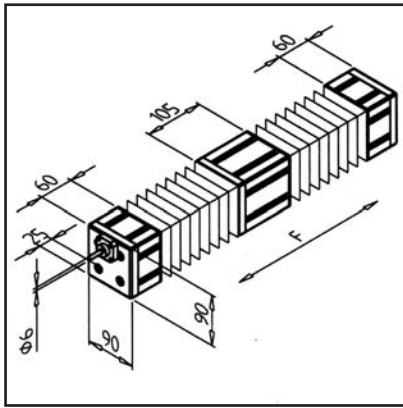
**TECHN. DATA / ITEMS SUPPLIED**

- Aluminium, anodized E6/EV1
- Ready-to-mount linear module of profile 90 x 90
- Drive unit with rolled circulating ball spindle RNCT 1003 Ø 10 mm, incline 3
- Incline fault/300: 12 µm (class C3)
- Slide guidance on 4 linear ball bearings with

- hardened ground precision shafts Ø 20 mm, total length max. 760 mm
- Shaft end on the fixed side machined according to customer specifications for engine or crank connection
- Shafts and spindles covered with protective bellows
- Positioning accuracy: ± 0,1 mm

APPLICATIONS

- Handling systems
- Z-axis in portals
- Multiple axis systems
- Grabbing units

LINEAR MODULE LB 180

Part no.

28.0179/0

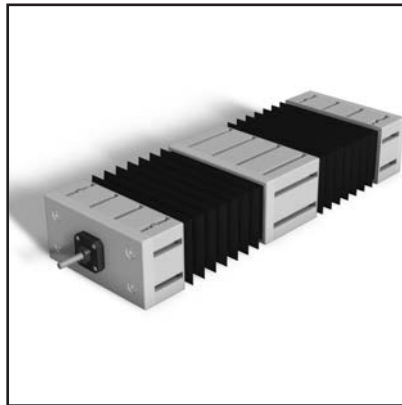
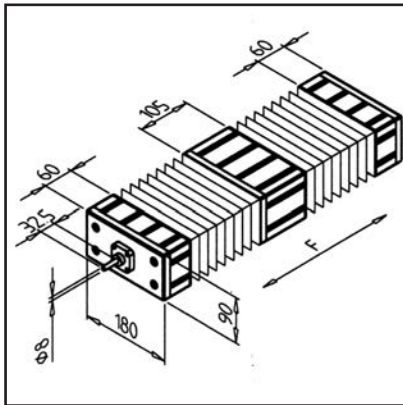
**TECHN. DATA / ITEMS SUPPLIED**

- Aluminium, anodized E6/EV1
- Ready-to-mount linear module of profile 90 x 180
- Drive unit with rolled circulated ball spindle RNCT 1404-3,4 Ø 14 mm, incline 4
- Incline fault/300: 12 µm (class C3)
- Slide guidance on 4 linear ball bearings with

- hardened ground precision shafts Ø 20 mm, total length max. 950 mm
- Shaft end on the fixed side machined according to customer specifications for engine or crank connection
- Shafts and spindles covered with protective bellows
- Positioning accuracy: ± 0,1 mm

APPLICATIONS

- Handling systems
- Z-axis in portals
- Multiple axis systems
- Grabbing units

SLIDE LB 45

Part no.

28.0150/0

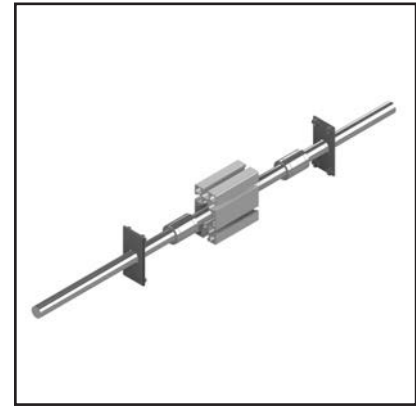
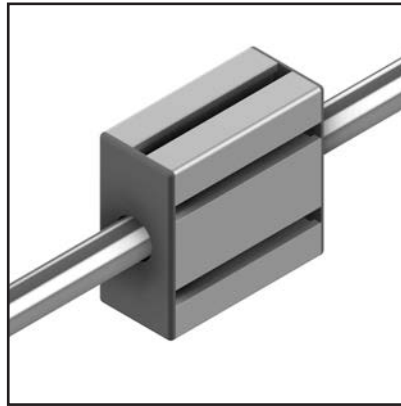
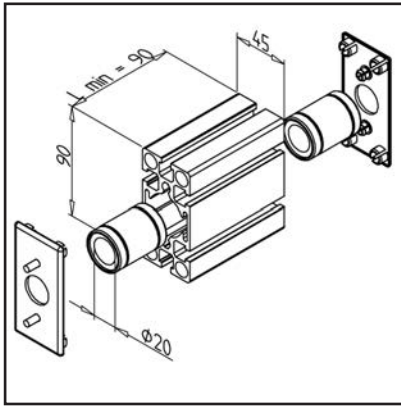

TECHN. DATA / ITEMS SUPPLIED

- Aluminium, anodized E6/EV1
- Standard length (L) 90 mm
- Profile 45 X 90 S
- Fully assembled with 2 ball bearing bushings LME 20 UU
- Profile closed on the front with cover plates LB 45
- **Other lengths on request**
- Weight = 0.550 kg/piece

APPLICATIONS

- All MiniTec linear systems LB

ASSEMBLY

- Lead shaft through slide

SLIDE LB 45 X 135

Part no.

28.0155/0

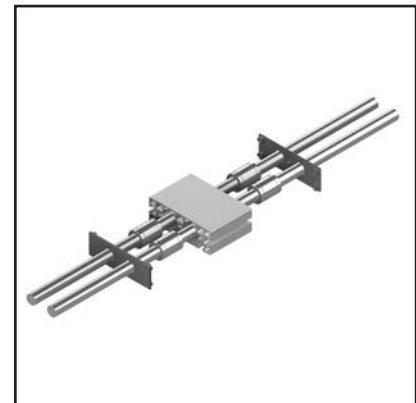
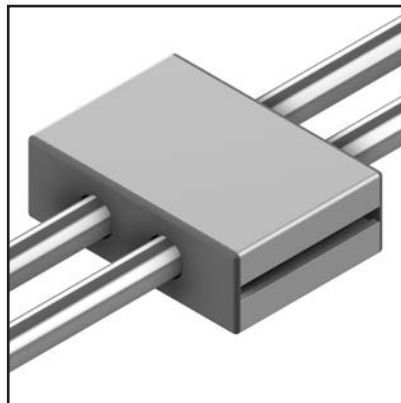
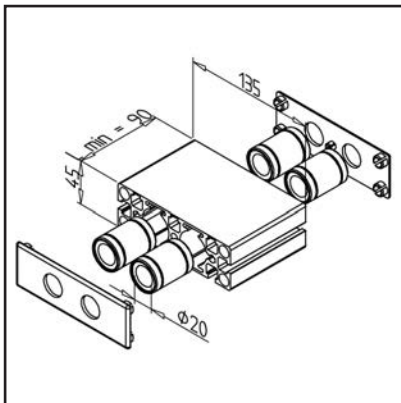

TECHN. DATA / ITEMS SUPPLIED

- Aluminium, anodized E6/EV1
- Standard length (L) 90 mm
- Profile 45 x 135
- Fully assembled with 2 ball bearing bushings LME 20 UU
- Profile face covered with end caps LB 45 x 135, grey
- **Other lengths on request**
- Weight = 0.865 kg/piece

APPLICATIONS

- All MiniTec linear systems LB

ASSEMBLY

- Lead shaft through slide

SLIDE LB 45 X 180

Part no.

28.0156/0

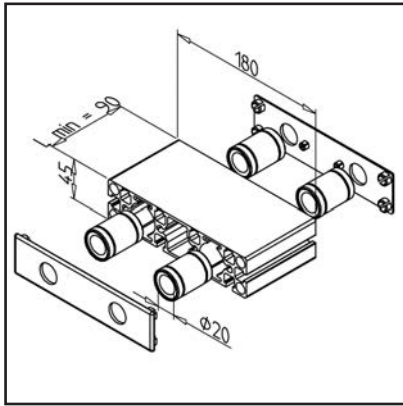
**TECHN. DATA / ITEMS SUPPLIED**

- Aluminium, anodized E6/EV1
- Standard length (L) 90 mm
- Profile 45 x 180
- Fully assembled with 2 ball bearing bushings LME 20 UU
- Profile face covered with end caps LB 45 x 180, grey
- **Other lengths on request**
- Weight = 1.007 kg/piece

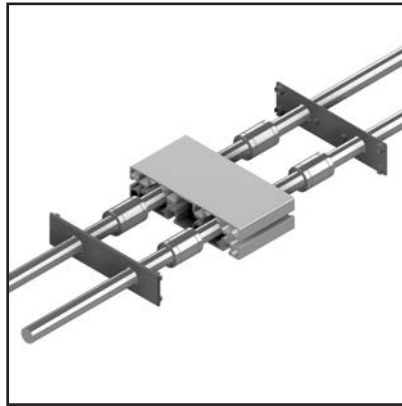
**APPLICATIONS**

- All MiniTec linear systems LB

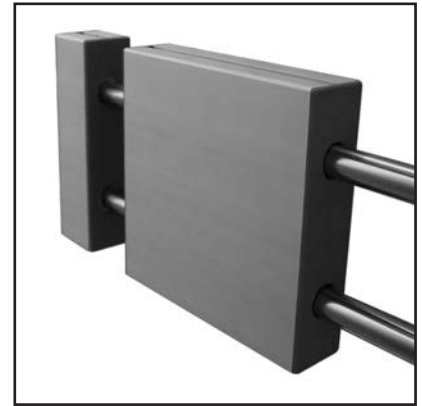
**ASSEMBLY**

- Lead shaft through slide

SLIDE LB 90

Part no.

28.0152/0

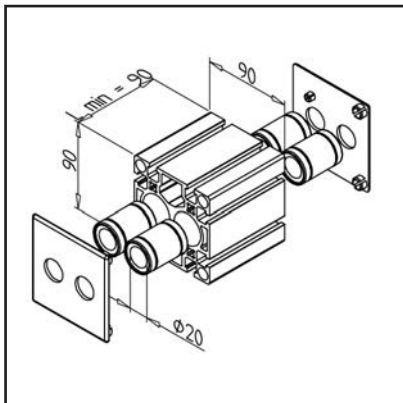
**TECHN. DATA / ITEMS SUPPLIED**

- Aluminium, anodized E6/EV1
- Standard length (L) 90 mm
- Profile 90 X 90 S
- Fully assembled with 4 ball bearing bushings LME 20 UU
- Profile face covered with end caps LB 90, grey
- **Other lengths on request**
- Weight = 1.070 kg/piece

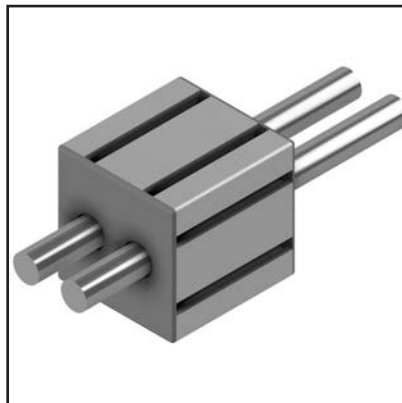
**APPLICATIONS**

- All MiniTec linear systems LB

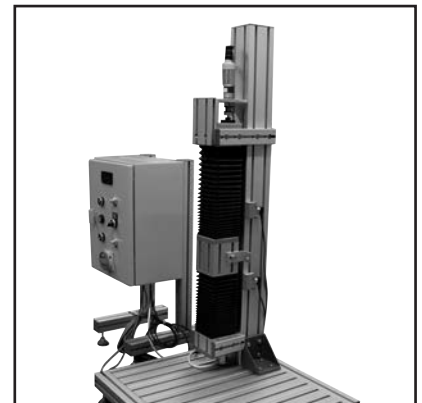
**ASSEMBLY**

- Lead shaft through slide

SLIDE LB 180

Part no.

28.0143/0

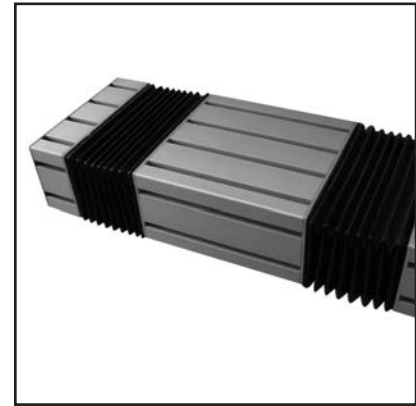
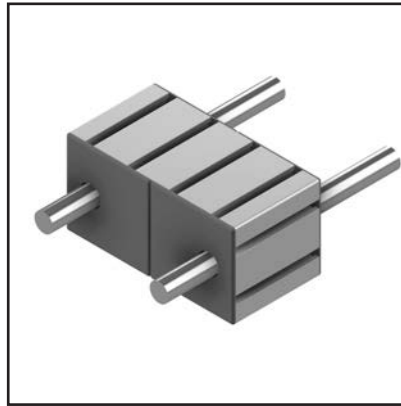
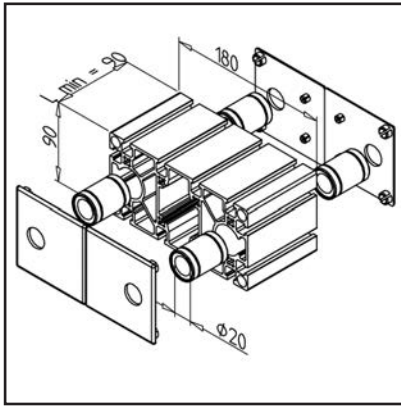

TECHN. DATA / ITEMS SUPPLIED

- Aluminium, anodized E6/EV1
- Standard length (L) 90 mm
- Profile 90 X 180 S
- Fully assembled with 4 ball bearing bushings LME 20 UU
- Profile face covered with end caps LB 180, grey
- **Other lengths on request**
- Weight = 1.500 kg/piece

APPLICATIONS

- All MiniTec linear systems LB

ASSEMBLY

- Lead shaft through slide

SHAFT SUPPORT WB 45

Part no.

28.0151/0

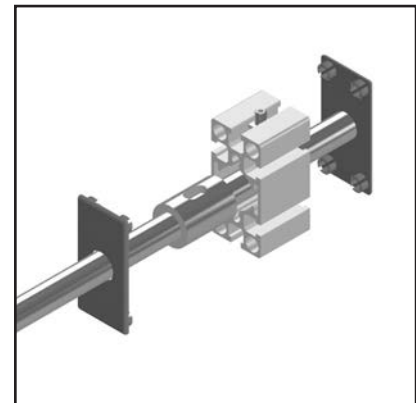
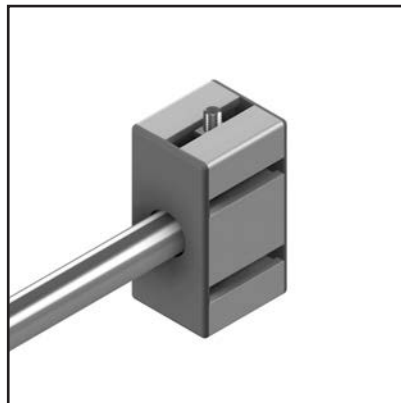
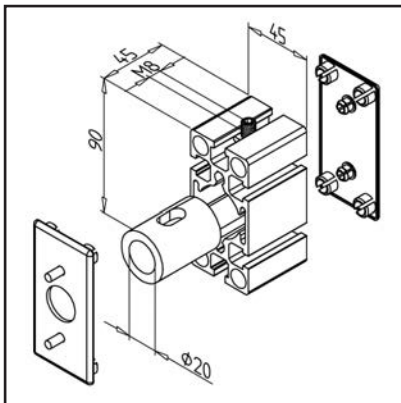

TECHN. DATA / ITEMS SUPPLIED

- Aluminium, anodized E6/EV1
- Profile 45 X 90 S
- Fully assembled with centering bushing
- Shaft side with end cap LB 45, grey
- Outer side with end cap 45 x 90, grey
- Weight = 0.266 kg/piece

APPLICATIONS

- Bearing and fastening of shaft Ø 20 mm in MiniTec-Linear systems LB 45

ASSEMBLY

- Insert shaft
- Tighten with set screw M8 x 35

SHAFT SUPPORT WB 45 X 135

Part no.

28.0157/0

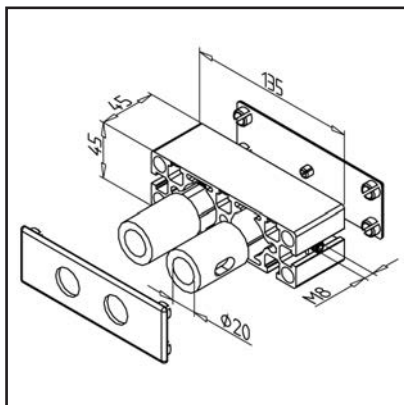
**TECHN. DATA / ITEMS SUPPLIED**

- Aluminium, anodized E6/EV1
- Profile 45 x 135
- Fully assembled with centering bushing
- Shaft side with end cap LB 45 x 135, grey
- Outer side with end cap 45 x 135, grey
- Weight = 0.416 kg/piece

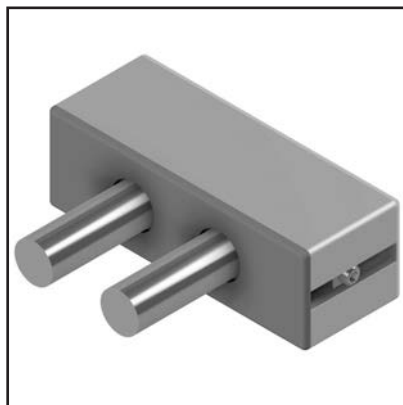
**APPLICATIONS**

- Bearing and fastening of shaft \varnothing 20 mm in MiniTec-Linear systems LB 45 x 135

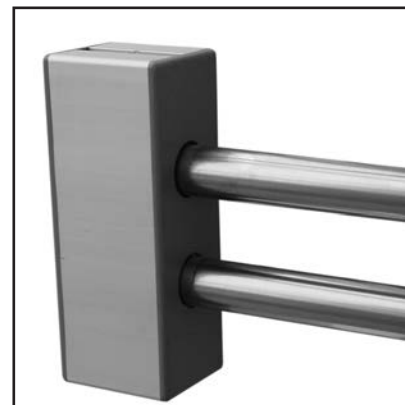
**ASSEMBLY**

- Insert shaft
- Tighten with set screw M8 x 35

SHAFT SUPPORT WB 45 X 180

Part no.

28.0159/0

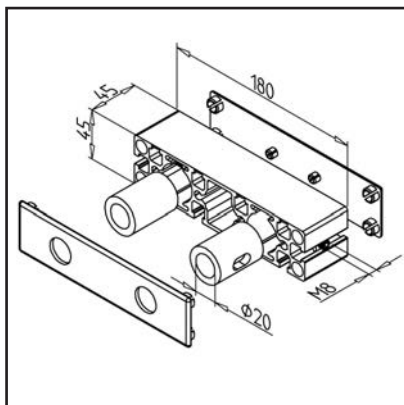
**TECHN. DATA / ITEMS SUPPLIED**

- Aluminium, anodized E6/EV1
- Profile 45 x 180
- Fully assembled with centering bushing
- Shaft side with end cap LB 45 x 180, grey
- Outer side with end cap 45 x 180, grey
- Weight = 0.486 kg/piece

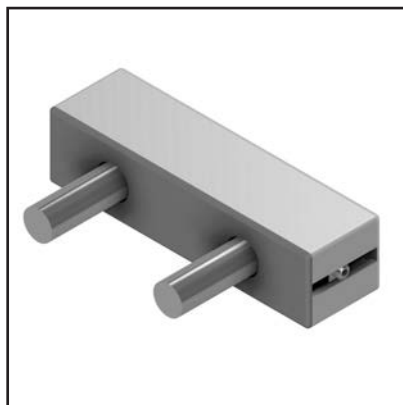
**APPLICATIONS**

- Bearing and fastening of shaft \varnothing 20 mm in MiniTec-Linear systems LB 45 x 180

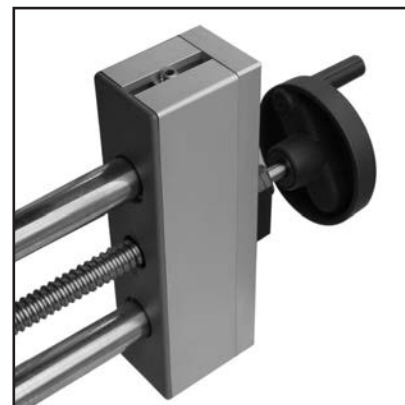
**ASSEMBLY**

- Insert shaft
- Tighten with set screw M8 x 35

SHAFT SUPPORT WB 90

Part no.

28.0153/0

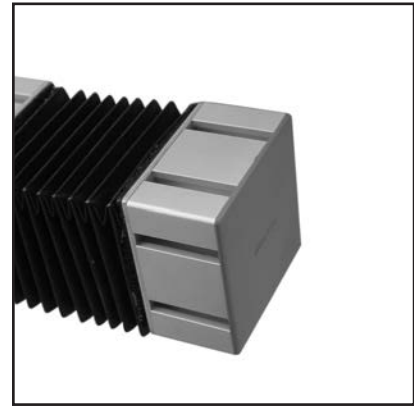
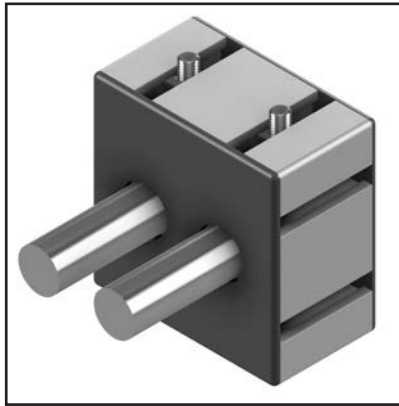
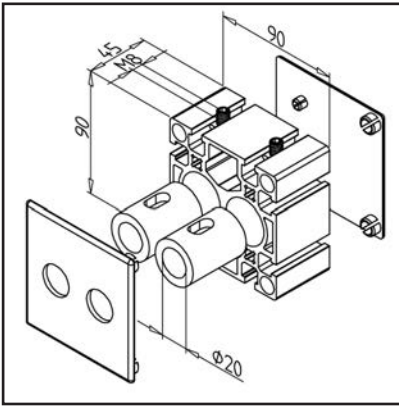

TECHN. DATA / ITEMS SUPPLIED

- Aluminium, anodized E6/EV1
- Profile 90 X 90 S
- Fully assembled with 2 centering bushings
- Shaft side with end cap LB 90, grey
- Outer side with end cap 90 x 90, grey
- Weight = 0.521 kg/piece

APPLICATIONS

- Bearing and fastening of shaft Ø 20 mm in MiniTec-Linear systems LB 90

ASSEMBLY

- Insert shaft
- Tighten with set screw M8 x 35

SHAFT SUPPORT WB 180

Part no.

28.0144/0

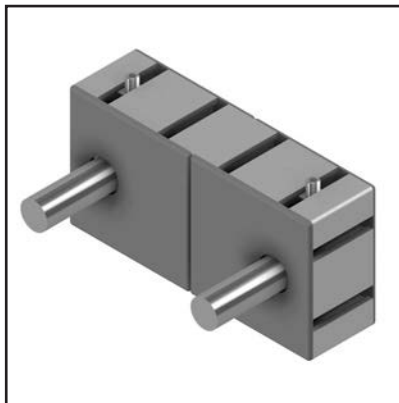
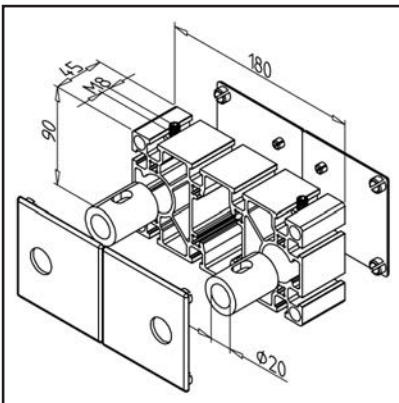

TECHN. DATA / ITEMS SUPPLIED

- Aluminium, anodized E6/EV1
- Profile 90 X 180 S
- Fully assembled with 2 centering bushings
- Shaft side with end cap LB 180, grey
- External side with 2 end caps 90 x 90, grey
- Weight = 0.755 kg/piece

APPLICATIONS

- Bearing and fastening of shaft Ø 20 mm in MiniTec-Linear systems LB 180

ASSEMBLY

- Insert shaft
- Tighten with set screw M8 x 35

PROFILE 45 X 90 S

Part no.

20.1017/0

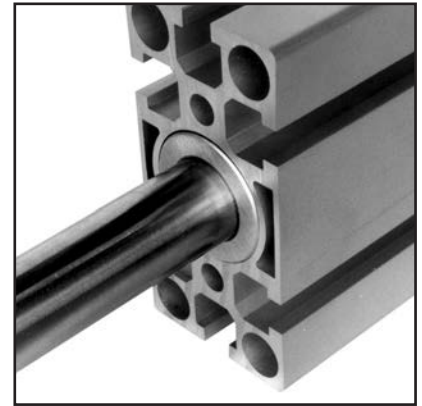
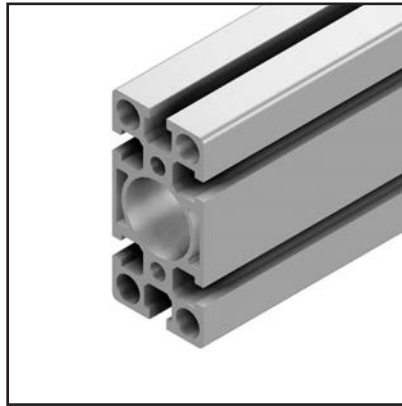
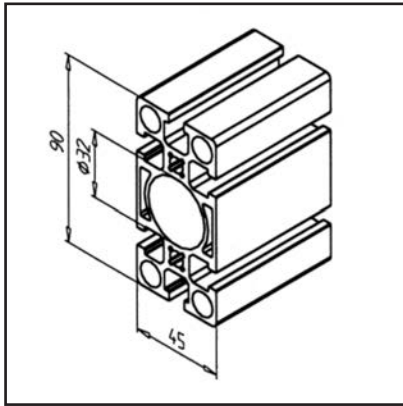
**TECHN. DATA / ITEMS SUPPLIED**

- Aluminium, extruded, anodized E6/EV1
- $I_x = 113.487 \text{ cm}^4$
- $I_y = 30.719 \text{ cm}^4$
- $w_x = 25.219 \text{ cm}^3$
- $w_y = 13.653 \text{ cm}^3$
- Weight = 3.860 kg/m
- Bar length = 6 m
- Packing unit = 24 m

APPLICATIONS

- All kinds of constructions
- Linear guides LB as slide
- Column guides
- Implementation as compressed air line with base and transport plate and sealing set
- Central bore $\varnothing 32 \text{ mm}$ for ball-bushings LME 20, for ball-bearings 6201 or 6002, for compressed air piping or guiding of hydraulic add-in cylinders

ASSEMBLY

- MiniTec power-lock fastener
- Mounting bracket 45 or 90
- Screw connection

PROFILE 45 X 135 1G

Part no.

20.1078/0

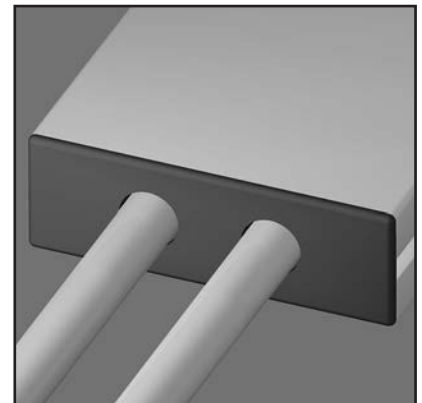
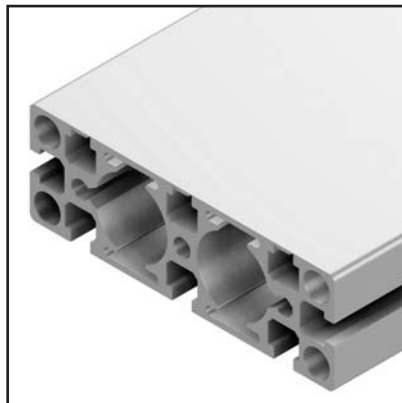
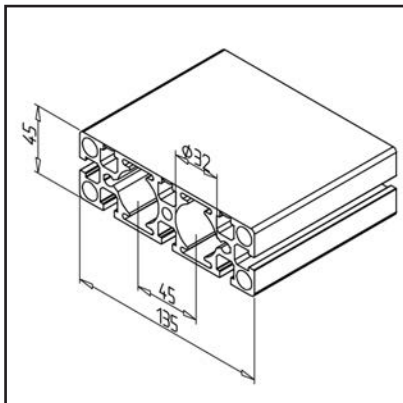
**TECHN. DATA / ITEMS SUPPLIED**

- Aluminium, extruded, anodized E6/EV1
- $I_x = 47.064 \text{ cm}^4$
- $I_y = 359.242 \text{ cm}^4$
- $w_x = 20.618 \text{ cm}^3$
- $w_y = 53.221 \text{ cm}^3$
- Weight = 5.570 kg/m
- Bar length = 6 m
- Packing unit = 12 m

APPLICATIONS

- All types of constructions, specifically for high hygiene requirements in the food industry, medical technology, bottling of beverages
- Linear guides LB as slide
- Central bore $\varnothing 32 \text{ mm}$ for ball-bushings LME 20, for ball-bearings 6201 or 6002, for compressed air piping or guiding of hydraulic add-in cylinders

ASSEMBLY

- MiniTec power-lock fastener
- closed grooves can be opened with the groove opener **part no. 26.0815/0** to the desired length

PROFILE 45 X 180 1G

Part no.

20.1079/0

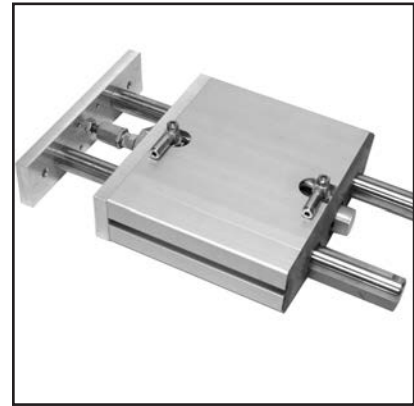
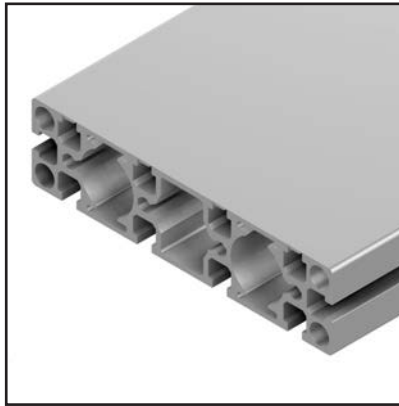
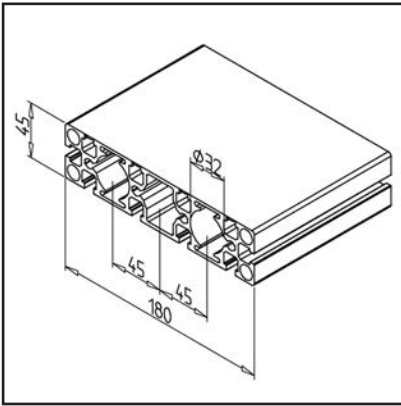
**TECHN. DATA / ITEMS SUPPLIED**

- Aluminium, extruded, anodized E6/EV1
- $I_x = 61.015 \text{ cm}^4$
- $I_y = 810.885 \text{ cm}^4$
- $w_x = 26.704 \text{ cm}^3$
- $w_y = 90.097 \text{ cm}^3$
- Weight = 6.950 kg/m
- Bar length = 6 m
- Packing unit = 12 m

APPLICATIONS

- All types of constructions, specifically for high hygiene requirements in the food industry, medical technology, bottling of beverages
- Linear guides LB as slide
- Central bore $\varnothing 32$ mm for ball-bushings LME 20, for ball-bearings 6201 or 6002, for compressed air piping or guiding of hydraulic add-in cylinders

ASSEMBLY

- MiniTec power-lock fastener
- closed grooves can be opened with the groove opener **part no. 26.0815/0** to the desired length

PROFILE 90 X 90 S

Part no.

20.1019/0

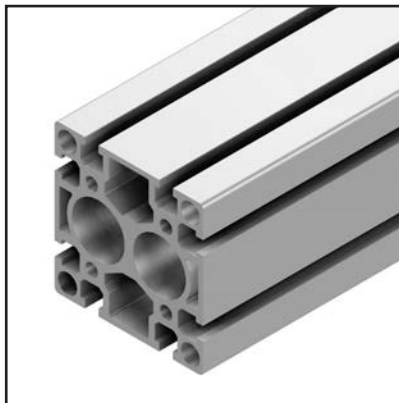
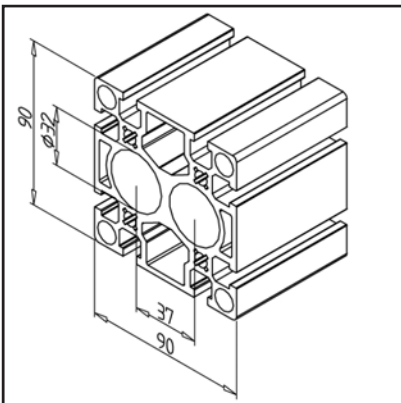
**TECHN. DATA / ITEMS SUPPLIED**

- Aluminium, extruded, anodized E6/EV1
- $I_x = 208.888 \text{ cm}^4$
- $I_y = 223.949 \text{ cm}^4$
- $w_x = 46.419 \text{ cm}^3$
- $w_y = 49.766 \text{ cm}^3$
- Weight = 7.514 kg/m
- Bar length = 6 m
- Packing unit = 12 m

APPLICATIONS

- All types of heavy constructions
- Linear guides LB as slide
- Central bore $\varnothing 32$ mm for ball-bushings LME 20, for ball-bearings 6201 or 6002, for compressed air piping or guiding of hydraulic add-in cylinders

ASSEMBLY

- MiniTec power-lock fastener
- Mounting bracket 45 or 90
- Screw connection

PROFILE 90 X 180 S

Part no.

20.1013/0

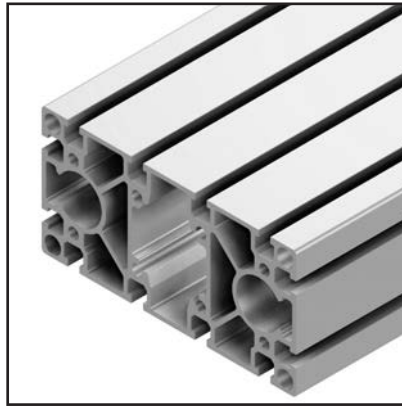
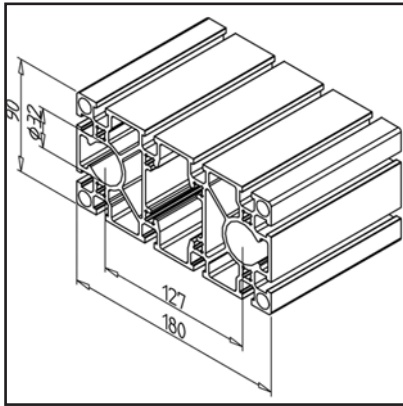
**TECHN. DATA / ITEMS SUPPLIED**

- Aluminium, extruded, anodized E6/EV1
- $I_x = 376.784 \text{ cm}^4$
- $I_y = 1421.865 \text{ cm}^4$
- $w_x = 83.729 \text{ cm}^3$
- $w_y = 157.983 \text{ cm}^3$
- Weight = 11.482 kg/m
- Bar length = 6 m
- Packing unit = 6 m

APPLICATIONS

- All types of heavy constructions
- Linear guides LB as slide
- Central bore $\varnothing 32 \text{ mm}$ for ball-bushings LME 20, for ball-bearings 6201 or 6002, for compressed air piping or guiding of hydraulic add-in cylinders

ASSEMBLY

- MiniTec power-lock fastener
- Mounting bracket 45 or 90
- Screw connection

BALL BEARING LME 20 UU

Part no.

10.1745/0

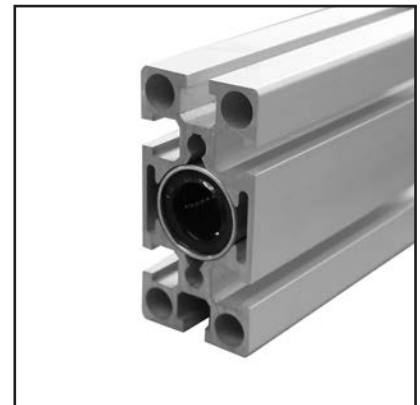
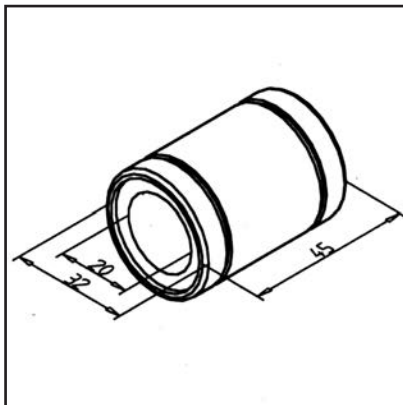
**TECHN. DATA / ITEMS SUPPLIED**

- Precision ball bushing with massive external sheath of 100Cr6
- 2 integrated sealing rings, heat resistant up to 80°C
- Load capacity:
- dyn. C = 880 N
- stat. $C_0 = 1400 \text{ N}$
- Weight = 0.090 kg/piece

APPLICATIONS

- Precision linear guides
- Linear slide system LB
- Lifting-tables
- Quattro-units

ASSEMBLY

- Press into bore $\varnothing 32 \text{ mm}$ of the profile
- Axial securing with single component adhesive for joining slide unit housing

CENTERING BUSHING

Part no.

28.0146/0

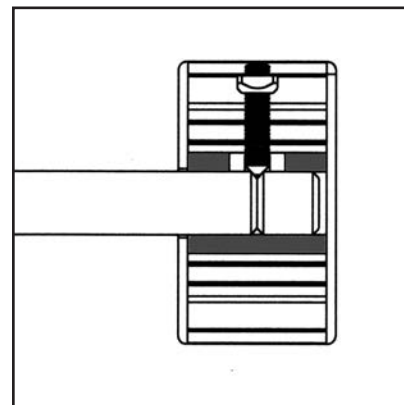
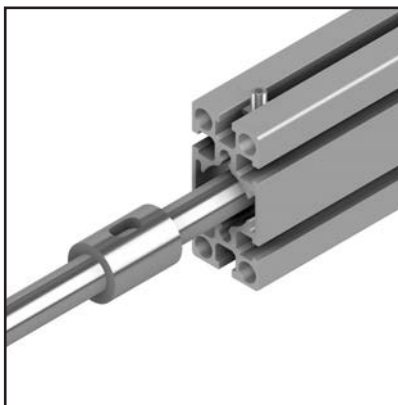
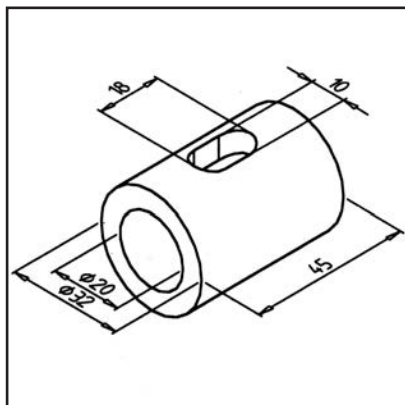

TECHN. DATA / ITEMS SUPPLIED

- Aluminium, bright
- Weight = 0.056 kg/piece

APPLICATIONS

- Central shaft clamping in all shaft blocks of the MiniTec linear systems LB

ASSEMBLY

- Insert centering bush in bore \varnothing 32 mm
- Insert shaft
- Clamps with threaded pin M8 x 35 **part no. 21.1304/1** and sliding nut **part no. 21.1351/0**

SHAFT 20

Part no.

17.1744/0

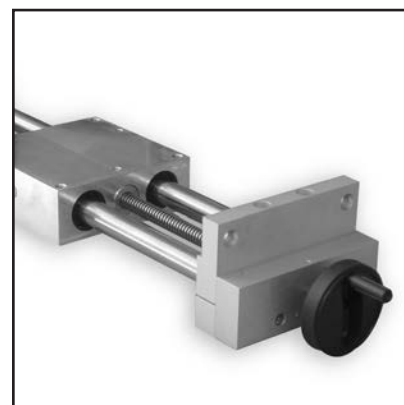
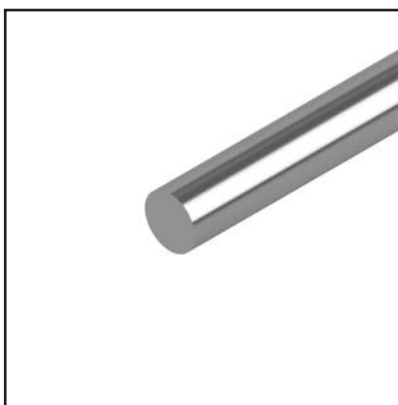
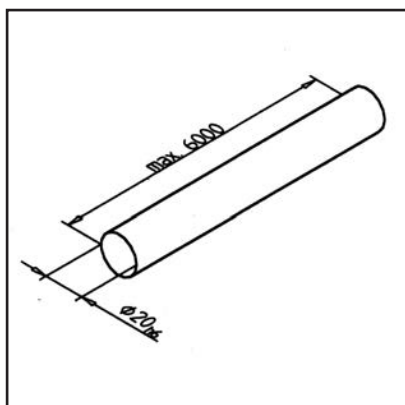

TECHN. DATA / ITEMS SUPPLIED

- Steel, pulled, hardened, polished
- Cf.53, hardened to 62 ± 4 HRC, polished h6
- Weight = 2.470 kg/m

APPLICATIONS

- Linear guide system LB

ASSEMBLY

- Secure with centering bushing into shaft bracket

SHAFT D 20 FOR LINEAR GUIDE LB

Part no.

28.0154/0

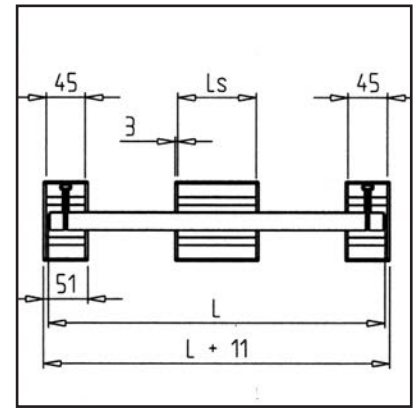
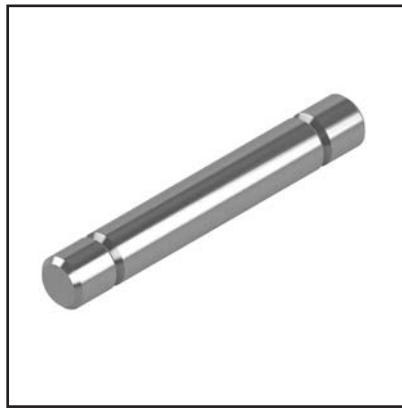
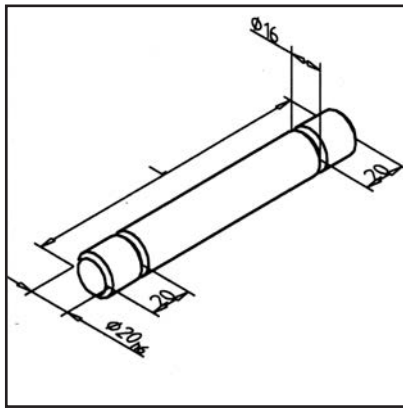

TECHN. DATA / ITEMS SUPPLIED

- Steel
- Cf53, surface-hardened to 60 + 5 HRC and pre-sharpened
- Tolerance h6
- Processed for shaft support block WB
- **Please specify dimension L**
- Weight = 2,470 kg/m

APPLICATIONS

- All MiniTec linear systems LB
- In each direction usable

ASSEMBLY

- Insert in shaft support
- Clamps with threaded pin M8 x 35 **part no. 21.1304/1**

END CAP LB 45

Part no.

28.0094/1

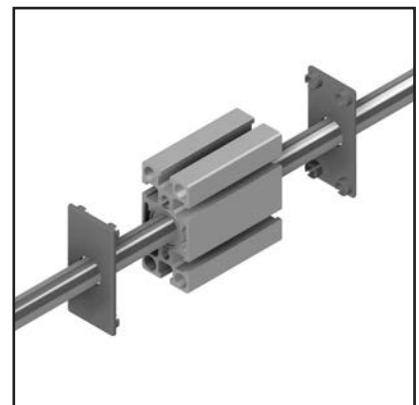
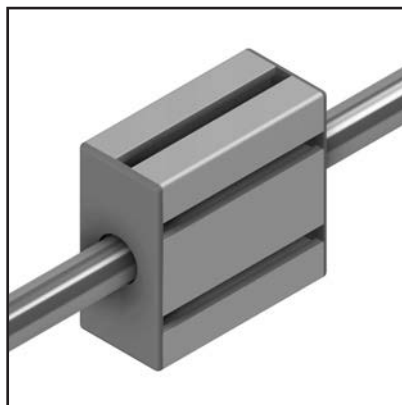
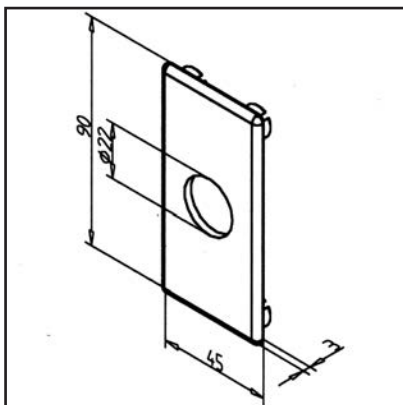

TECHN. DATA / ITEMS SUPPLIED

- ABS, Injection Mould, grey
- Aging and oil resistant
- On request also available in black, **part no. 28.0094/0**
- 1 centric bore \varnothing 22 mm
- Weight = 0.010 kg/piece

APPLICATIONS

- Front slide cover LB 45
- Face covering of shaft support block WB 45 (shaft side)

ASSEMBLY

- Press the fastening pins into the profile holes

END CAP LB 45 X 135

Part no.

28.0101/1

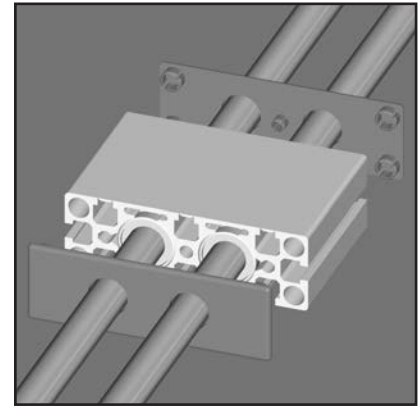
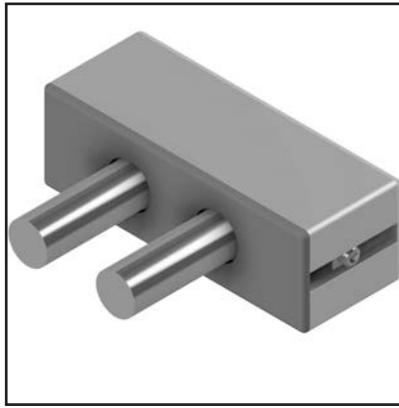
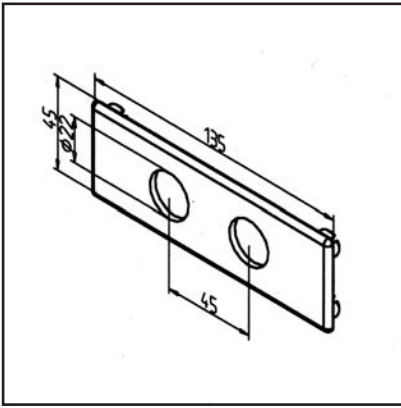

TECHN. DATA / ITEMS SUPPLIED

- ABS, Injection Mould, grey
- Aging and oil resistant
- On request also available in black, **part no. 28.0101/0**
- 2 bores \varnothing 22 mm
- Weight = 0.010 kg/piece

APPLICATIONS

- Front slide cover LB 45 x 135
- Front cover of shaft blocks WB 45 x 135

ASSEMBLY

- Press the fastening pins into the profile holes

END CAP LB 45 X 180

Part no.

28.0102/1

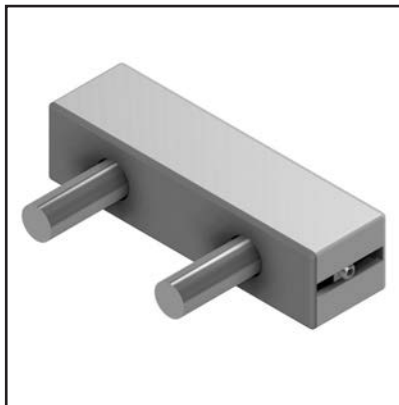
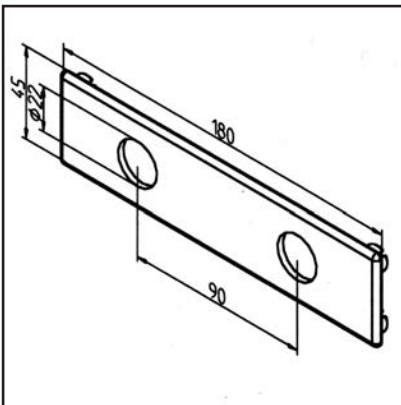

TECHN. DATA / ITEMS SUPPLIED

- ABS, Injection Mould, grey
- Aging and oil resistant
- On request also available in black, **part no. 28.0102/0**
- 2 bores \varnothing 22 mm
- Weight = 0.010 kg/piece

APPLICATIONS

- Front slide cover LB 45 x 180
- Front cover of shaft blocks WB 45 x 180

ASSEMBLY

- Press the fastening pins into the profile holes

END CAP LB 90

Part no.

28.0095/1

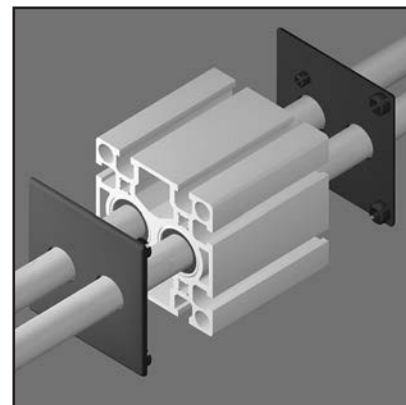
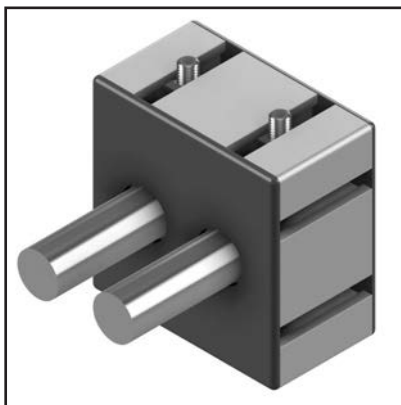
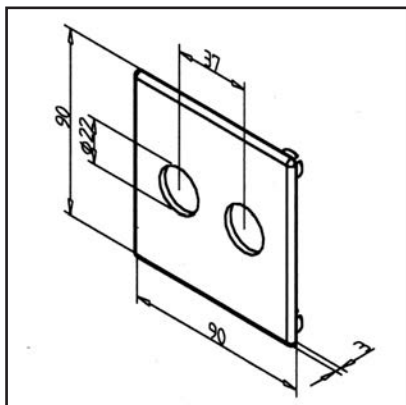
**TECHN. DATA / ITEMS SUPPLIED**

- ABS, Injection Mould, grey
- Aging and oil resistant
- On request also available in black, **part no. 28.0095/0**
- 2 bores \varnothing 22 mm
- Weight = 0.018 kg/piece

APPLICATIONS

- Front slide cover LB 90
- Front cover of shaft blocks WB 90

ASSEMBLY

- Press the fastening pins into the profile holes

END CAP LB 180

Part no.

28.0103/1

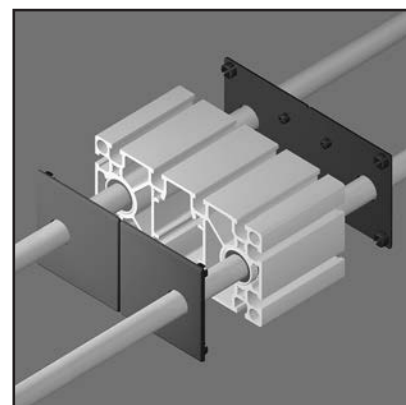
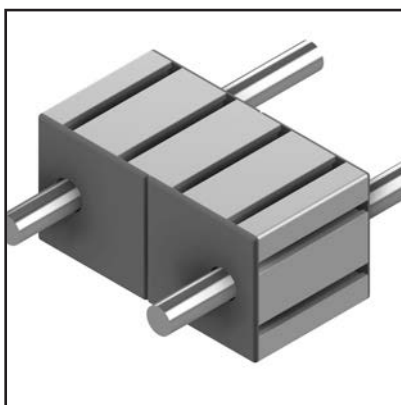
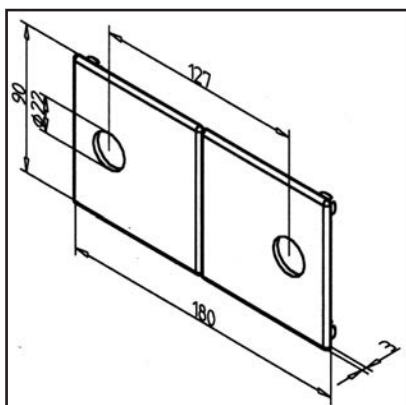
**TECHN. DATA / ITEMS SUPPLIED**









- ABS, Injection Mould, grey
- Aging and oil resistant
- On request also available in black, **part no. 28.0103/0**
- 2 bores \varnothing 22 mm
- Weight = 0.037 kg/piece

APPLICATIONS

- Front slide cover LB 180
- Front cover of shaft blocks WB 180

ASSEMBLY

- Press the fastening pins into the profile holes

	3.1	WORKSTATIONS	362
	3.2	HEIGHT ADJUSTABLE WORKSTATIONS	364
	3.3	TABLETOPS	373
	3.4	COUNTER CABINETS	377
	3.5	LIGHTING	385
	3.6	ENERGY SUPPLY	389
	3.7	EQUIPMENT	391
	3.8	FOOT RESTS	389
	3.9	PNEUMATICS	436
	3.10	KANBAN-SYSTEMS	439
	3.11	LIFTER	451
	3.12	ASSEMBLY DEVICES	456
	3.13	ESD-ACCESSORIES	459

WORKPLACE DESIGN



The MiniTec profile system and the MiniTec iCADassembler have been setting standards for many years in the design of production flow, workstations, factory automation and machine protection.

Tailor-made workplaces avoid disadvantageous compromises. The MiniTec modular system with the corresponding software are the basis for economical and fast realization of the optimal problem solution. All system components are compatible and can be combined into production systems. Flexibility and economy do not have to be competing goals. Manual workstations allow a highly flexible reaction to changing requirements or are ideal for individual production. In combination with the many linking possibilities from the MiniTec range, even complex manufacturing systems can be designed economically. Manual components - such as roller conveyors, roller tracks for KanBan solutions or material trolleys - are available for linking the workstations. Automatic linking is produced with linear axes, belt



conveyors or the flexible transfer system TSG. Our design software MiniTec iCADassembler is freely available for designing the workstations. Workstations in a wide variety of designs are designed individually by the software in the shortest possible time. The system automatically creates the bill of materials and, if required, an assembly plan. Automatic design modules for linear technology, protective devices and conveyor systems are also available.

Our electronic catalogue also contains all components of the MiniTec modular system with interfaces to all common CAD systems.

WORKPLACE DESIGN



The design of the workstations is described according to ergonomic findings in DIN EN ISO 6385. The task of ergonomic design is, among other things, to adapt the workplace, work area, environment and lighting to the characteristics and abilities of the human being. The modular system for designing individual workstations enables optimum adaptation to the respective task and the individual employee.

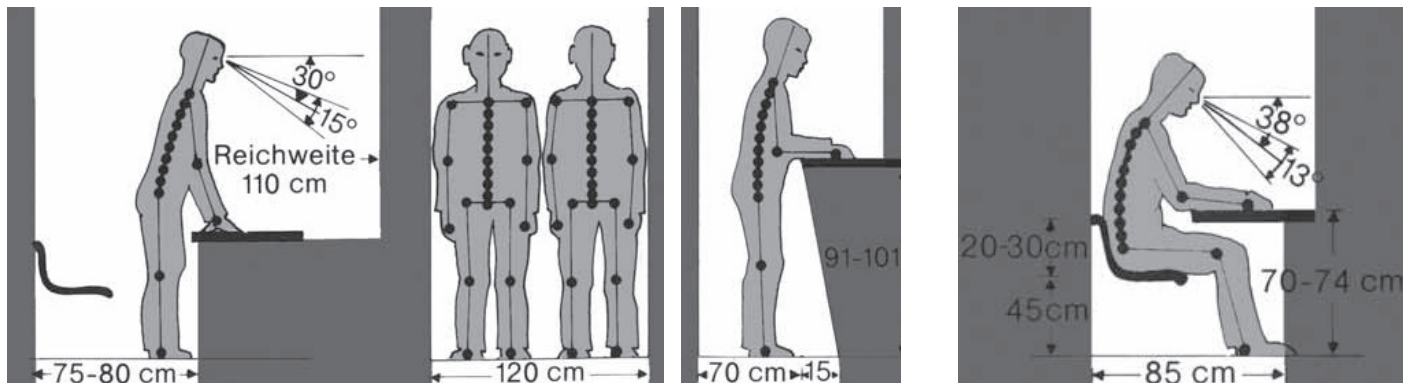
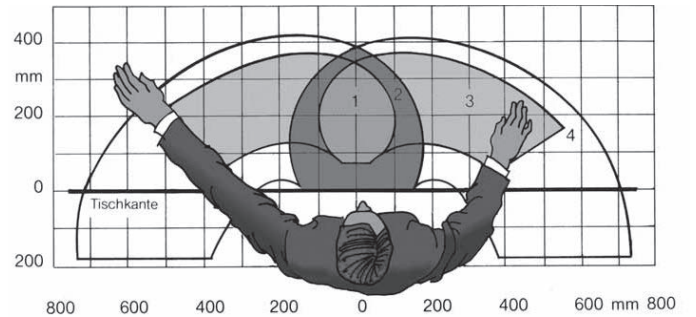

EXAMPLE PICTURES



WORKSTATIONS

The workstation belongs to the standard equipment in the productive areas of many companies. Due to its flexible, ergonomic and goal-oriented Design is the basis for extremely economical flexible workstation systems. On the next pages we introduce the different worktable models.



BASIC WORKSTATIONS

Individual. The MiniTec workstations from the modular system.

MiniTec offers you different base frames with or without portal construction. You can either define the dimensions yourself or use standard variants with given dimensions.

Workstation



Workstation L with portal



Workstation S with reinforced portal construction



Sample application

Sample application

Sample application

		Workstations			
		Preferred dimensions			
Width (B)	variable	1000	1200	1500	2000
Depth (T)	variable	700			
Depth (T1)	variable	555			
Height (H)	variable	678			
Height (H1)	variable	2100			
Height (H2)	variable	100			
max. load capacity [N] Type L/S	variable	1500	1000	800	800/1200
Workstation	32.0111/0	32.0111/1	32.0111/2	32.0111/3	32.0111/4
Workstation L with portal	32.0112/0	32.0112/1	32.0112/2	32.0112/3	32.0112/4
Container table S with portal	32.0113/0	32.0113/1	32.0113/2	32.0113/3	32.0113/3

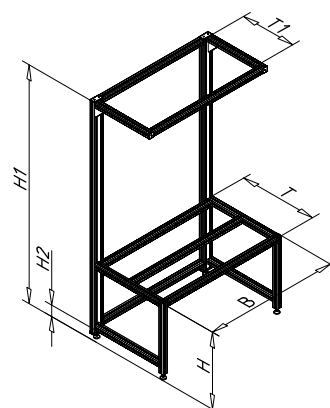
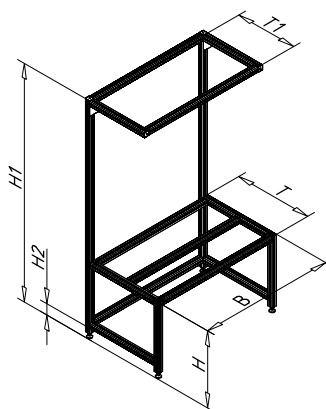
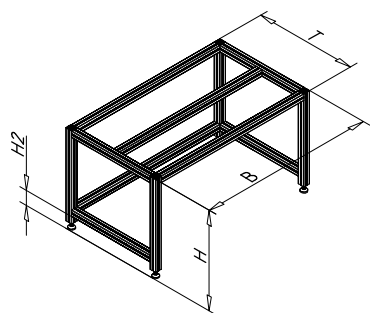

- Our basic workstations are available without a portal, with portal or reinforced portal
- The base frame of our workstations consists of the profile 45 x 45 F, anodised E6 /EV1.
- The frame is mounted electrically conductive with the MiniTec power-lock fastener.
- To compensate for uneven floors, the bases are equipped with articulated feet PA, spindle M10 plate Ø45mm.
- The racks are supplied without Tabletops and the necessary mounting brackets for tabletops.
- The workstation S with portal has a reinforced portal structure and can be loaded more heavily with a table width of 2000mm

HEIGHT ADJUSTABLE WORKSTATIONS

Always at the right height.

Ergonomic design represents a particular challenge in workplace design, as it significantly influences the health, performance, endurance, concentration and not least the motivation of the workers.

The height-adjustable MiniTec workstations are also available hydraulic and electric height adjustment. In addition to a se-

lection of standard tables with fixed dimensions, the tables can also be freely configured and easily supplemented with portal structures if required.

HYDRAULICALLY ADJUSTABLE
WORKSTATIONS

Example application - stroke 300 (hydraulic)

ELECTRICALLY HEIGHT ADJUSTABLE
WORKSTATIONS

Example application - stroke 400 (electrical)

- The base frame of the hydraulically height-adjustable tables consists of the profile 45x90 F and 45x45 F, anodised E6/EV1.
- To compensate for uneven floors (+/- 10 mm), the base frames are equipped with PA articulated feet, M10 spindle Ø80mm disc.
- A large selection of Tabletops can be found page373
- The height adjustment is available with either 300 or 400 mm stroke. Lifting speed: 5 mm / crank rotation.

PORTAL CONSTRUCTIONS



Portal construction

Electr. height adjustable workstation
with portal

- Thanks to the modular principle, both hydraulically and electrically height-adjustable worktables can be quickly and easily supplemented with portal structures if required.

HEIGHT ADJUSTABLE WORKSTATIONS

Hydraulically height adjustable workstations

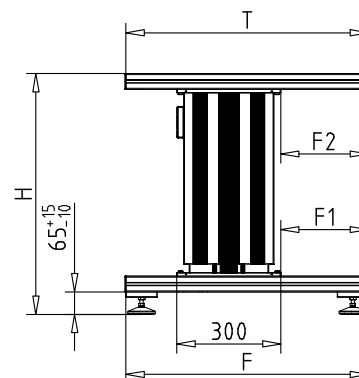
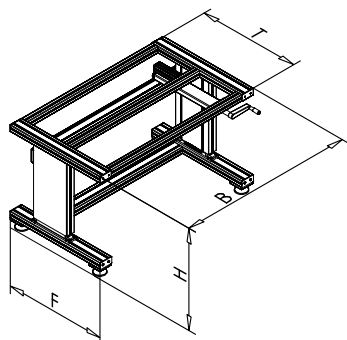

Table - stroke 300



Sample application

Hydraulically height adjustable tables					
		Preferred dimensions in mm			
Width (B)	variable	1000	1200	1500 U/min	2000
Depth (T)	variable	700			
Height (H)		695 (stroke 300) / 795 (stroke 400)			
F	variable	700			
F1	variable	253			
F2	variable	253			
max. Load [N]	variable	1500	1000	800	1200
Hydraulically height adjustable table - stroke 300	32.0170/0	32.0170/1	32.0170/2	32.0170/3	32.0170/4
Hydraulically height adjustable table - stroke 400	32.0171/0	32.0171/1	32.0171/2	32.0171/3	32.0171/4



- The base frame of the hydraulically height adjustable tables consists of the profile 45x90 F and 45x45 F, anodised E6/EV1.
- To compensate for uneven floors (+/- 10 mm), the base frames are equipped with PA articulated feet, M10 spindle Ø80mm disc.
- The racks are supplied without tabletops and the necessary mounting brackets for tabletops.
- A large selection of Tabletops can be found page 373
- The height adjustment is available with either 300 or 400 mm stroke. Lifting speed: 5 mm / crank rotation.
- The hand pump with retractable hand crank is mounted under the Tabletop.

HEIGHT ADJUSTABLE WORKSTATIONS

Electrically height adjustable workstations



Stroke 300 mm



Sample application

Electrically height-adjustable tables					
		Preferred dimensions in mm			
Width (B)	variable	1000	1200	1500	2000
Depth (T)	variable	700			
Height (H)		695 (stroke 300) / 795 (stroke 400)			
F	variable	700			
F1	variable	253			
F2	variable	253			
max. Load [N]	variable	1500	1000	800	1200
Electrically height-adjustable table - stroke 300	32.0172/0	32.0172/1	32.0172/2	32.0172/3	32.0172/4
Electrically height-adjustable table - stroke 400	32.0173/0	32.0173/1	32.0173/2	32.0173/3	32.0173/4

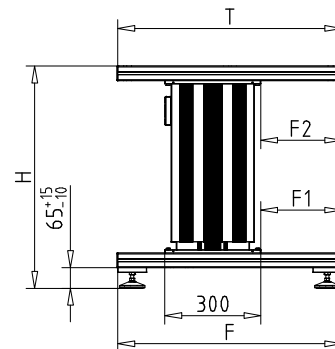
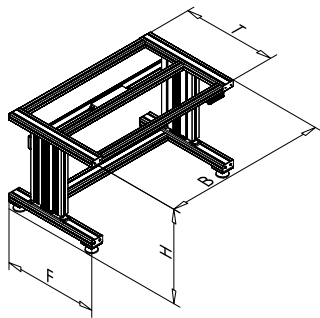

- The base frame of the electrically height-adjustable tables consists of the profile 45x90 F and 45x45 F, anodized E6/EV1.
- To compensate for uneven floors (+/- 10 mm), the base frames are equipped with PA articulated feet, M10 spindle Ø80mm disc.
- The racks are supplied without Tabletops and the necessary mounting brackets for Tabletops.
- A large selection of Tabletops can be found page373
- The height adjustment is available with either 300 or 400 mm stroke. The max. Lifting speed is 9 mm/s.
- Operation is via a manual switch with 3-digit display, two buttons for up / down function and four storable positions.

Portal constructions



Portal construction



Sample application

Portal constructions					
Width (B)	variable	Preferred dimensions in mm			
		1000	1200	1500	2000
Depth (T1)	variable	500			
Height (H3)	variable	1455			
Portal constructions	320174/0	320174/1	320174/2	320174/3	320174/4

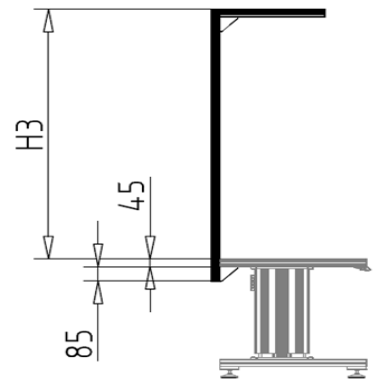
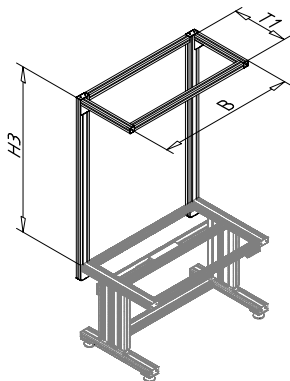

- Thanks to the modular design principle, both the hydraulically and electrically height-adjustable worktables can be quickly and easily supplemented with portal structures if required.
- The portal structures can either be freely configured or ordered in predefined standard dimensions.

The ergonomically optimal working height for every application

The workers expect that their desks and the tools and objects to be gripped are adapted to their individual needs and arranged at the correct height. A fatigue or even damage to the body must be avoided from the outset. In order to meet this requirement - regardless of the respective application - MiniTec offers

three different flexible lift systems made of colourless anodized aluminum profiles with different lifting and installation heights at.

Hydraulic lift system „HLS 1G“

Electric lift system „ELS 1G“

Electric lift system „ELS“



	HLS 1G		ELS 1G		ELS L		ELS S	
	Stroke 300	Stroke 400	Stroke 300	Stroke 400	Stroke 350	Stroke 400	Stroke 350	Stroke 400
Max. system load capacity [N] for 2-3 columns	3000		6000		3200		6400	
Pressure force per column [N]	1500		3000		1600		3200	
Tensile force dyn/stat [N]	0		50/500		800		1600	
Installation height	540	640	540	640	545	595	545	595
Number of fixing grooves	4		4		6		6	
Suitable for mobile solutions	yes		no		no		no	
Lifting speed	5mm per turn of the crank		9 mm/s		9 mm/s		9 mm/s	
Synchronous operation possible up to max.	10 lifting columns		12 lifting columns		12 lifting columns		12 lifting columns	
Flexible number of columns by user	no		yes*		no		no	
Number of lifting columns is automatically detected by the controller	-		yes*		no		no	

* 1 to 3 columns are automatically recognized - more than 3 columns on request

APPLICATIONS

- Height adjustment of individual workplaces & complete packaging, assembly and manufacturing equipment as well as office units & furniture in general, material supply, fixtures

Hydraulic lift system „HLS 1G“

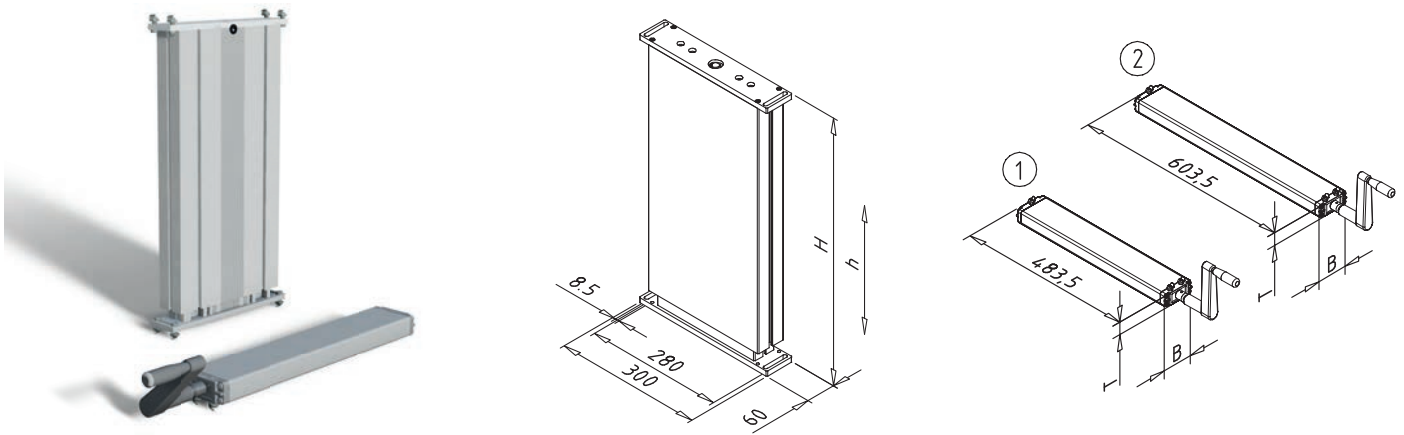

Hydraulic lift system HLS 1G							
Type	Stroke h	Installation height H	Pump type	Number of columns			
				1	2	3	4
HLS-300S-1G	300 mm	540 mm	1	HLS-300S/540-1000-1G-1	HLS-300S/540-3000-1G-2	HLS-300S/540-3000-1G-3	HLS-300S/540-3000-1G-4
				Part no. 32.0182/1	Part no. 32.0182/2	Part no. 32.0182/3	Part no. 32.0182/4
HLS-400S-1G	400 mm	640 mm	2	HLS-400S/640-1000-1G-1	HLS-400S/640-3000-1G-2	HLS-400S/640-3000-1G-3	HLS-400S/640-3000-1G-4
				Part no. 32.0183/1	Part no. 32.0183/2	Part no. 32.0183/3	Part no. 32.0183/4
Max. system load capacity				1000 N	3000 N	3000 N	3000 N
Pump width/depth				85/35 mm		120/60 mm	
Higher loads and more than 4 lifting columns on request							

APPLICATION

- Height adjustment of individual workplaces & complete packaging, assembly and manufacturing equipment as well as office units & furniture in general, material supply, fixtures, material supply

TECHNICAL DATA

- Anodised aluminum profile E6 / EV1 with plastic glides
- 4 mounting grooves on 3 sides allow on total
- Column length attachment of trusses, clipboards as well as attachments and superstructures
- Lifting speed: 5 mm each turn of the crank
- max. static bending moment: 1500 Nm
- max. dynamic bending moment: 150 Nm Single-acting hydraulics: restoring force necessary!
- Restoring force = [(1.5kg x hose length in m) + 6kg] x number of columns
- Hose length per column: 4m
- Installation position: only pressing. The system must not be loaded with tension (if necessary, provide for transport lock)
- Synchronous operation: up to max. 10 columns possible
- Ambient temperature: + 10 ° to + 40 ° C
- IP 30

Electric lift system „ELS 1G“

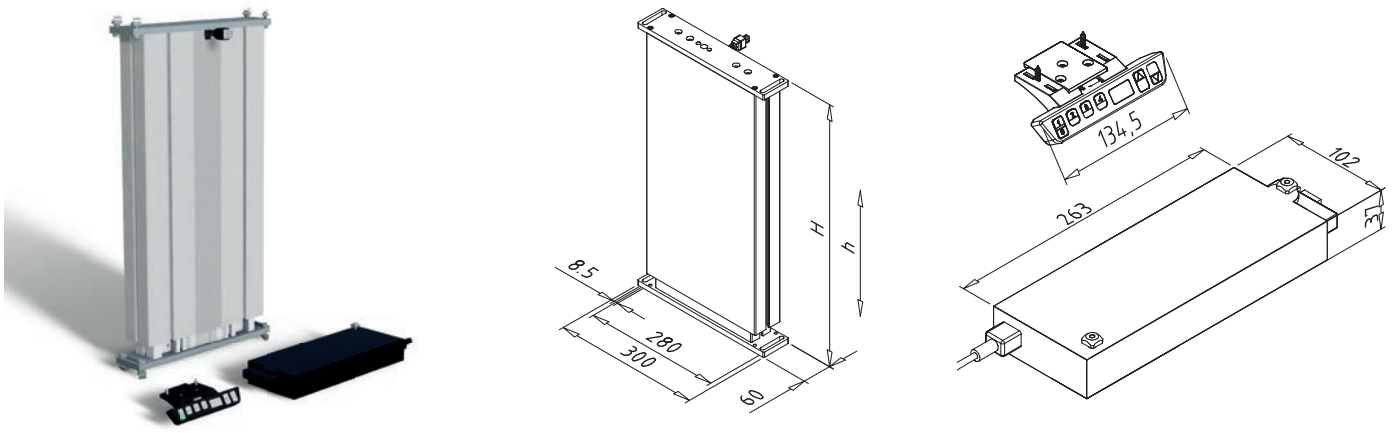

Electric lift system ELS 1G					
Type	Stroke h	Installation height H	Anzahl der Säulen		
			1	2	3
ELS-300-1G	300 mm	540 mm	ELS-300/540-3000-1G-1	ELS-300/540-6000-1G-2	ELS-300/540-6000-1G-3
			Part no. 32.0180/1	Part no. 32.0180/2	Part no. 32.0180/3
ELS-400-1G	400 mm	640 mm	ELS-400/640-3000-1G-1	ELS-400/640-6000-1G-2	ELS-400/640-6000-1G-3
			Part no. 32.0181/1	Part no. 32.0181/2	Part no. 32.0181/3
Max. system load capacity			3000 N	6000 N	6000 N
Higher loads and more than 3 columns on request					

APPLICATION

- Height adjustment of individual workplaces & complete packaging, assembly and manufacturing equipment as well as office units & furniture in general

TECHNICAL DATA

- Anodised aluminum profile E6 / EV1 with plastic glides
- 4 mounting grooves on 3 sides make it possible to mount trusses, clipboards as well as attachments and superstructures over the entire leg length
- Lifting speed: 9mm/s
- Drive: Internal DC drive with built-in limit switches and 2 Hall sensors
- max. bending moments / column: in the longitudinal direction 1200 Nm static, 450 Nm dynamic; in the transverse direction 550 Nm static, 200Nm dynamic
- max. tensile load/column: 500N static, 50N dynamic
- Cable feed per column: L=1700mm
- Cable outlet on the large profile on the inside
- IP 30
- Duty cycle: 10 % (S3) during periodic operation and max. load (2 min. ON /18 min. OFF)
- Installation position: preferably pushing
- Synchronous operation: up to max. 12 columns possible
- Ambient temperature: +10° bis +40°C
- Control system: Synchronous control for controlling up to 3 columns „Plug & Play“ (bis zu 12 auf Anfrage)
- Manual switch: with display and memory function
- Items supplied: Electric lifts with mounting hardware, synchronous control and manual switch
- Accessories: motor extension cable, Part no.: 27.0109/0
Manual switch extension cable, Part no.: 27.0110/0

Electric lift system „ELS”

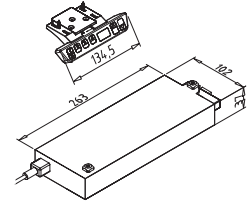
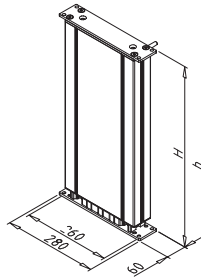

Electric lift system ELS L					
Type	Stroke h	Installation height H	ELS-350/545-1600-L-1 Part No.: 32.1540/1S		
			1	2	3
ELS-350 L	350 mm	545 mm	ELS-350/545-1600-L-1	ELS-350/545-3200-L-2	ELS-350/545-3200-L-3
			Part no. 32.1540/1	Part no. 32.1540/2	Part no. 32.1540/3
ELS-400 L	400 mm	595 mm	ELS-400/595-1600-L-1	ELS-400/595-3200-L-2	ELS-400/595-3200-L-3
			Part no. 32.1510/1	Part no. 32.1510/2	Part no. 32.1510/3
Max. system load capacity			1600 N	3200 N	3200 N
Higher loads and more than 3 columns on request					

Electric lift system ELS S - for higher loads					
Type	Stroke h	Installation height H	ELS-350/545-1600-L-1 Part No.: 32.1540/1S		
			1	2	3
ELS-350 S	350 mm	545 mm	ELS-350/545-3200-S-1	ELS-350/545-6400-S-2	ELS-350/545-6400-S-3
			Part no. 32.1530/1	Part no. 32.1530/2	Part no. 32.1530/3
ELS-400 S	400 mm	595 mm	ELS-400/595-3200-S-1	ELS-400/595-6400-S-2	ELS-400/595-6400-S-3
			Part no. 32.1500/1	Part no. 32.1500/2	Part no. 32.1500/3
Max. system load capacity			3200 N	6400 N	6400 N
Higher loads and more than 3 columns on request					

APPLICATION

- Height adjustment of individual workplaces & complete packaging, assembly and manufacturing equipment as well as office units & Furniture in general - for ergonomically optimal working height

TECHNICAL DATA

- Anodised aluminum profile E6 / EV1 with plastic glides
- 4 mounting grooves on 3 sides make it possible to mount trusses, clipboards as well as attachments and superstructures over the entire leg length
- Lifting speed: 9mm/s
- Drive: Internal DC drive with built-in limit switches and 2 Hall sensors
- Max. Bending moments / column: in the longitudinal direction 1200 Nm static, 500 Nm dynamic; in the transverse direction 450 Nm static, 255Nm dynamic
- Max. tensile load/column: 500N static, 50N dynamic
- Cable supply per column: L=1200mm;
- Cable outlet on large profile on the inside
- IP 30 Duty cycle: 10% (S3) for periodic operation and max. Load (2 min. ON / 18 min. OFF)
- Installation position: preferably pushing
- Synchronous operation: up to max. 12 columns possible
- Ambient temperature: + 10 ° to + 40 ° C
- Control: Synchronous control for up to 3 columns „Plug & Play” (up to 12 on request)
- Handset: Handset with display and memory function
- Scope of delivery: Electric lifts with fixing material, synchronous control and handset
- Accessories: Motor extension cable, part no.: 32.0042/0 Handset extension cable, part no.: 27.0110/0

HEIGHT SETTING FOR WORKTABLE

Part no.

32.0335/0

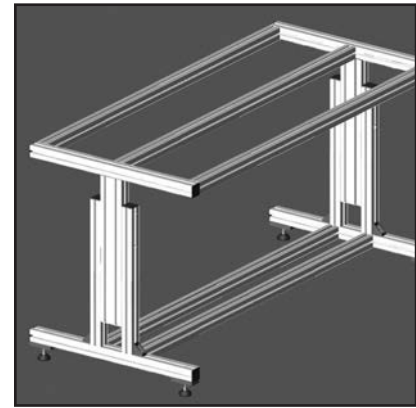
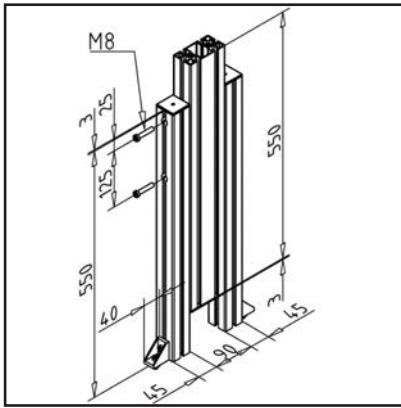

TECHN. DATA / ITEMS SUPPLIED

- from profile 45x45 F and 45x90 F, anodized E6/EV1
- Installation dimension: 553mm
- Adjustable range: 385mm

- ESD-compatible **part no. 32.0335/6**
- 1x height adjustment fully assembled.
- Weight = 3.192 kg/piece

APPLICATIONS

- Simple height-adjustment through double profiles
- Adjustable through release of the screwed fastening

PNEUMATIC LIFT SYSTEM PLS - 415

Part no.

32.0360/0

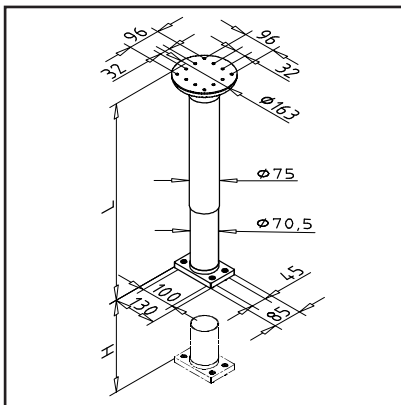

TECHN. DATA / ITEMS SUPPLIED

- With adapter plate at the bottom and fastening material
- Diameter 75mm
- Lifting capacity: 120 N
- Stroke (H): 415mm
- Installation dimension (L) retracted: 640mm
- Optionally also **part no. 32.0361/0**
Stroke (H): 225 mm
Installation dimension (L): 450 mm
- Weight = 5.383 kg/piece

APPLICATIONS

- For raising and lowering the work tables and other equipment
- Activation / release: Bowden cable L=280mm

ASSEMBLY

- Install to the profile groove with supplied hardware

TABLETOPS



For the different assembly tasks, a selection of Tabletops is available.
 The maximum plate sizes can also be found on the following pages in the item description.
 Within the listed dimensions we can realize every special dimension.
 The Tabletops are fixed to the base frame with mounting bracket 25 GD-Z and chipboard screws.

	Scratch	Abrasion	Stroke	Warmth	Humidity	Oil	Chemicals	ESD, antistatic	Light reflection	Layer thickness
Melamine	●	●	●	●	●	●	●	○	●	0,2
Laminate	●	●	●	●	●	●	●	○	●	0,8
HPL	●	●	●	●	●	●	●	○	●	3
Multiplex	●	●	●	●	●	●	●	○	●	-
Melamine conductive	●	●	●	●	●	●	●	●	●	0,2
PE 500 R	●	●	●	●	●	●	●	○	○	-
HPL Compact tabletop	●	●	●	●	●	●	●	○	●	-
HPL ESD Compact tabletop	●	●	●	●	●	●	●	●	●	-

● Very suitable

● conditionally suitable

● little suitable

○ not suitable

TABLETOPS

part no.	Article	Color	Thickness (mm)	Width W (mm)	Depth D (mm)
32.0410/0	Tabletop melamine	Light grey RAL 7035	22mm	B= (≤2760mm)	T= (≤2060mm)
32.4110/0	Tabletop melamine	Light grey RAL 7035	22mm	1000mm	700mm
32.4120/0	Tabletop melamine	Light grey RAL 7035	22mm	1200mm	700mm
32.4140/0	Tabletop melamine	Light grey RAL 7035	22mm	1500mm	700mm
32.4160/0	Tabletop melamine	Light grey RAL 7035	22mm	2000mm	700mm
32.4200/0	Tabletop hard laminate	Light grey RAL 7035	20mm	B= (≤2750mm)	T= (≤1250mm)
32.4210/0	Tabletop hard laminate	Light grey RAL 7035	20mm	1000mm	700mm
32.4220/0	Tabletop hard laminate	Light grey RAL 7035	20mm	1200mm	700mm
32.4240/0	Tabletop hard laminate	Light grey RAL 7035	20mm	1500mm	700mm
32.4260/0	Tabletop hard laminate	Light grey RAL 7035	20mm	2000mm	700mm
32.4700/0	Tabletop hard laminate	Light grey RAL 7035	40mm	B= (≤2750mm)	T= (≤1250mm)
32.4710/0	Tabletop hard laminate	Light grey RAL 7035	40mm	1000mm	700mm
32.4720/0	Tabletop hard laminate	Light grey RAL 7035	40mm	1200mm	700mm
32.4740/0	Tabletop hard laminate	Light grey RAL 7035	40mm	1500mm	700mm
32.4760/0	Tabletop hard laminate	Light grey RAL 7035	40mm	2000mm	700mm
32.0440/0	Tabletop multiplex beech	Polished, natural	20mm	B = (≤2460mm)	T = (≤1460mm)
32.4410/0	Tabletop multiplex beech	Polished, natural	20mm	1000mm	700mm
32.4420/0	Tabletop multiplex beech	Polished, natural	20mm	1200mm	700mm
32.4440/0	Tabletop multiplex beech	Polished, natural	20mm	1500mm	700mm
32.4460/0	Tabletop multiplex beech	Polished, natural	20mm	2000mm	700mm
32.0490/0	Tabletop multiplex beech	Polished, natural	40mm	B = (≤2460mm)	T = (≤1460mm)
32.4910/0	Tabletop multiplex beech	Polished, natural	40mm	1000mm	700mm
32.4920/0	Tabletop multiplex beech	Polished, natural	40mm	1200mm	700mm
32.4940/0	Tabletop multiplex beech	Polished, natural	40mm	1500mm	700mm
32.4960/0	Tabletop multiplex beech	Polished, natural	40mm	2000mm	700mm
Clearcoating or oiled on request					

TABLETOPS

part no.	Article	Color	Thickness (mm)	Width W (mm)	Depth D (mm)
32.0460/0	ESD-Tabletop melamine	Light grey RAL 7035	25mm	B = (≤ 2760 mm)	T = (≤ 2060 mm)
32.4610/0	ESD-Tabletop melamine	Light grey RAL 7035	25mm	1000mm	700mm
32.4620/0	ESD-Tabletop melamine	Light grey RAL 7035	25mm	1200mm	700mm
32.4640/0	ESD-Tabletop melamine	Light grey RAL 7035	25mm	1500mm	700mm
32.4660/0	ESD-Tabletop melamine	Light grey RAL 7035	25mm	2000mm	700mm
32.6100/0	Tabletop PE 500 R	Confetti	25mm	B= (≤ 3000 mm)	32.6100/0
32.6110/0	Tabletop PE 500 R	Confetti	25mm	1000mm	700mm
32.6120/0	Tabletop PE 500 R	Confetti	25mm	1200mm	700mm
32.6140/0	Tabletop PE 500 R	Confetti	25mm	1500mm	700mm
32.6160/0	Tabletop PE 500 R	Confetti	25mm	2000mm	700mm
The colour spread may vary in shape, size and colour depending on the delivery.					
32.6000/0	Tabletop PE 500 R	black	25mm	B= (≤ 3000 mm)	T= (≤ 1250 mm)
32.6010/0	Tabletop PE 500 R	black	25mm	1000mm	700mm
32.6020/0	Tabletop PE 500 R	black	25mm	1200mm	700mm
32.6040/0	Tabletop PE 500 R	black	25mm	1500mm	700mm
32.6060/0	Tabletop PE 500 R	black	25mm	2000mm	700mm
plate made of aluminium, PVC, stainless steel or requested material					
32.6204/0	HPL Compact tabletop	Light grey	20mm	B= (≤ 2520 mm)	T= (≤ 1280 mm)
32.6208/0	HPL ESD Compact tabletop	Light grey	20mm	B= (≤ 2520 mm)	T= (≤ 1280 mm)

Mounting angle for tabletops

Part no.
32.0401/0

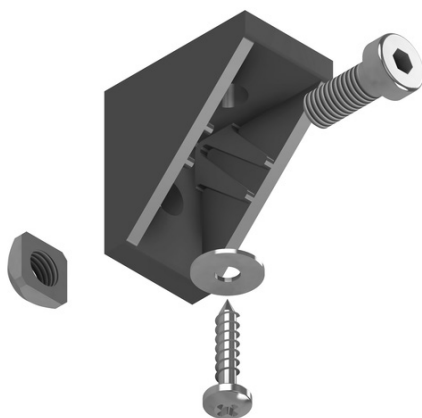

Technical Data:

- Mounting angle 25; Chip-board screw with washer; Cylinder head screw with sliding nut
- For Tabletops from 22 mm
- Für EPA/ESD Anwendungen Part no. 32.0401/6
- Weight 0,058 kg

Application:

- Fixing Tabletops from 22 mm on the profile frame

Assembly:

- Fasten with fastening material from the scope of delivery to the profile groove
- For retrofitting to a vertical groove, preferably square nut M8 with groove fixing, Part no. 21.1351/2 use
- Screw chipboard screw with washer into Tabletop, if necessary pre-drill

PROFILE 270 X 19

Part no.

20.1077/0

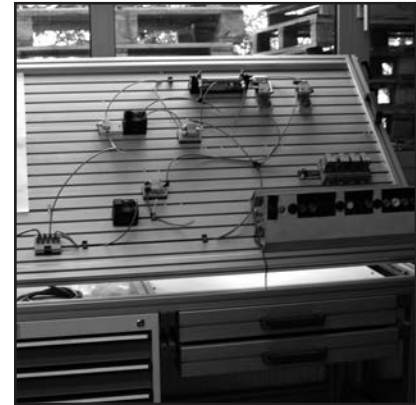
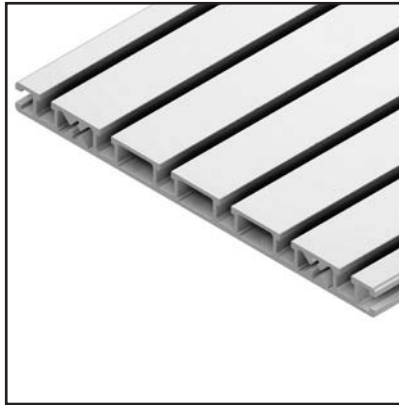
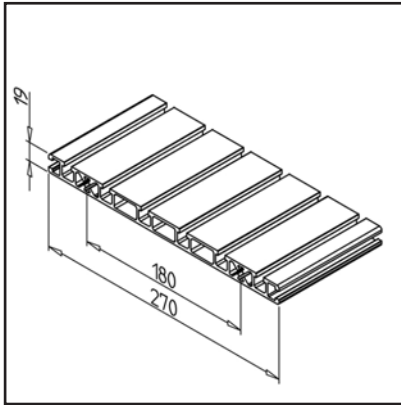
**TECHN. DATA / ITEMS SUPPLIED**

- Aluminium, extruded, anodized E6/EV1
- $I_x = 10.348 \text{ cm}^4$
- $I_y = 1352.197 \text{ cm}^4$
- $w_x = 10.167 \text{ cm}^3$
- $w_y = 100.162 \text{ cm}^3$
- Weight = 5.612 kg/m
- Bar length = 6 m
- Packing unit = 18 m

APPLICATIONS

- Mounting plates
- Workstations
- Training set-ups for training and further education with universal clamping base **part no. P2.0060/0**
- Demonstration units

ASSEMBLY

- MiniTec power-lock fastener
- Screw connection
- Bolt connector

DRAWER BASE CABINETS

Drawer base cabinets ensure perfect order at the workplace. There are the right ones for every need. Usable heights, subdivisions or deposits. All base cabinets are available for right or left extension.

Casing:

- Sheet steel construction
- Load-bearing capacity: to 200 kg
- Standard with central lock, single pullout lock and cylinder lock with 2 keys
- Easy construction

Drawers:

- The individual drawers can be loaded up to 35 kg, 80% extendable, perforated bottom
- Standard with large handle with label
- Standard paint:
 - Casing light grey RAL 7035
 - Drawer / Door brilliant blue RAL 5007
- Standard painting in ESD version:
 - Completely light grey RAL 7035

■ Paintings Optional*:

- grey green, HF 0001 (similar. RAL 6000)
- resedagreen, RAL 6011
- light grey, RAL 7035
- light blue, RAL 5012
- ruby red, RAL 3003
- water blue, RAL 5021
- anthracite, RAL 7016
- red orange, RAL 2001
- brilliant blue, RAL 5007
- alu-silver, (similar) RAL 9006

*at the same price as standard



FASTENING SET FLOOR CABINET

Part no.

32.0806/0

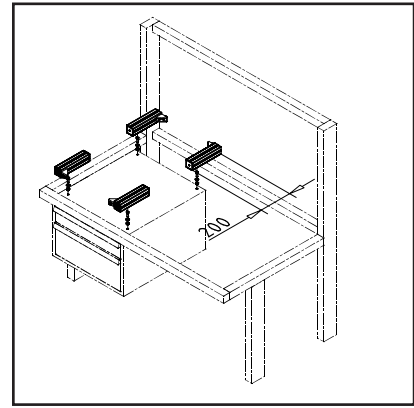
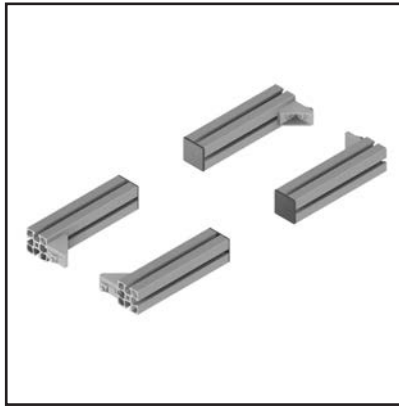
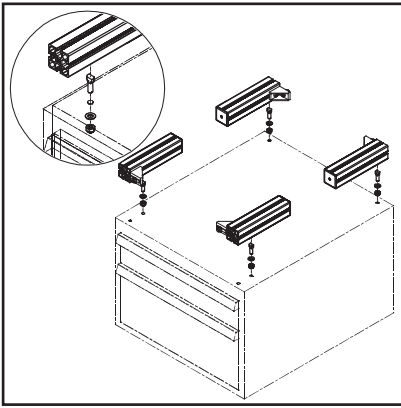

TECHN. DATA / ITEMS SUPPLIED

- Aluminium, anodized E6/EV1
- Composed of:
 - 4x Profile 45x45 - L=200 mm
 - 4x Mounting bracket 25 S
 - 4x Hammer head screw M8 with nut
- Suitable for ESD-designs
- Weight = 1.951 kg/piece

APPLICATIONS

- For the attachment of floor cabinets on table frame

ASSEMBLY

- With fastening material included
- Screw fastening set on base frame
- Remove drawers from counter cabinet
- Place the hammer screws on the cabinet
- Swing in the cabinet with the hammer screws in the profile groove, tighten the nuts

DRAWER BASE CABINET 200

Part no.

32.0809/0

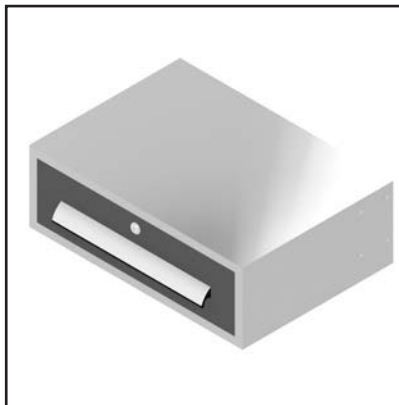
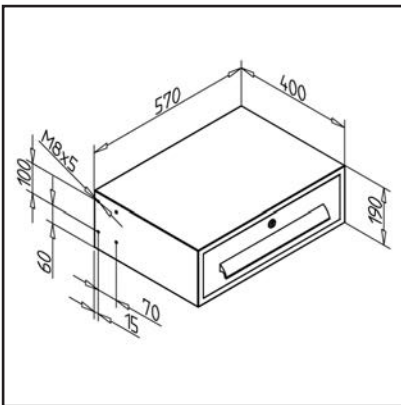

TECHN. DATA / ITEMS SUPPLIED

- Steel, lacquered
- Without fastening kit
- Color:
 - Corpus light grey RAL 7035
 - Drawer brilliant blue RAL 5007

- Cylinder lock with 2 keys
- Max. load capacity: 35kg
- Large handle bar with label adapter
- Can be pulled out up to 80 %
- Weight = 10.410 kg/piece

ASSEMBLY

- Use side threads or drill your own holes
- Alternatively with mounting set for under counter cabinet **part no. 32.0806/0** Insert 4 x 8.5 holes at the appropriate location

DRAWER BASE CABINET 150/150

Part no.

32.0810/0

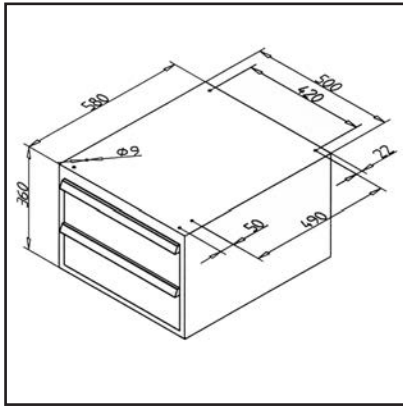
**TECHN. DATA / ITEMS SUPPLIED**

- Steel, lacquered
- With fastening material steel, zinc plated
- Color:
 - Corpus light grey RAL 7035
 - Drawer brilliant blue RAL 5007
- Cylinder lock with 2 keys, center locking for all drawers
- Individual drawer locking
- 2 drawers, H = 150 mm, with perforated

- bottom
- Large handle bar with label adapter
- Can be pulled out up to 80 %
- Drawer inside W = 425 mm T = 550 mm, effective height = H-10 mm
- Max. load capacity per compartment 35kg
- Max. load capacity per cabinet: 200 kg
- Weight = 22.570 kg/piece

ASSEMBLY

- Use fastening kit to fasten to base frame
- Alternatively attach with mounting set **part no. 32.0806/0** to strut profiles of the base frame
- Also in ESD version **part no. 32.0810/6**
- Optionally available in different colors **part no. 32.0810/2**

DRAWER BASE CABINET 100/200

Part no.

32.0811/0

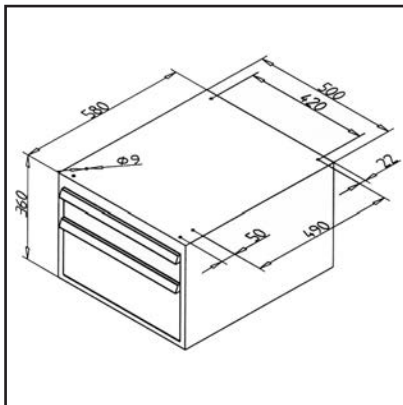
**TECHN. DATA / ITEMS SUPPLIED**

- Steel, lacquered
- With fastening material steel, zinc plated
- Color:
 - Corpus light grey RAL 7035
 - Drawer brilliant blue RAL 5007
- Cylinder lock with 2 keys, center locking for all drawers
- Individual drawer locking
- 1 drawer H = 100 mm, 1 drawer H = 200

- mm, with perforated bottom
- Large handle bar with label adapter
- Can be pulled out up to 80 %
- Drawer inside W = 425 mm T = 550 mm, effective height = H-10 mm
- Max. load capacity per compartment 35kg
- Max. load capacity per cabinet: 200 kg
- Weight = 22.570 kg/piece

ASSEMBLY

- Use fastening kit to fasten to base frame
- Alternatively attach with mounting set **part no. 32.0806/0** to strut profiles of the base frame
- Also available in ESD version **part no. 32.0811/6**
- Optionally available in different colors **part no. 32.0811/2**

DRAWER BASE CABINET 50/100/150

Part no. 32.0812/0

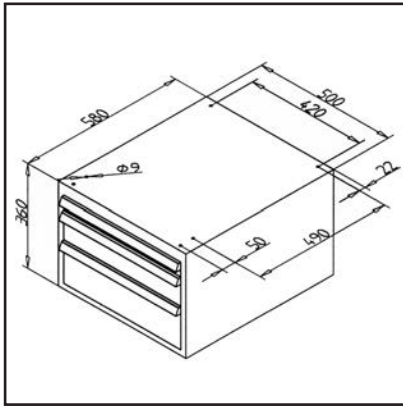

TECHN. DATA / ITEMS SUPPLIED

- Steel, lacquered
- With fastening material steel, zinc plated
- Color:
 - Corpus light grey RAL 7035
 - Drawer brilliant blue RAL 5007
- Cylinder lock with 2 keys, center locking for all drawers
- Individual drawer locking
- 1 drawer H = 50 mm, 1 drawer H = 100 mm, 1 drawer H = 150 mm, with perforated bottom
- Large handle bar with label adapter
- Can be pulled out up to 80 %
- Drawer inside W = 425 mm T = 550 mm, effective height = H-10 mm
- Max. load capacity per compartment 35kg
- Max. load capacity per cabinet: 200 kg
- Weight = 33.000 kg/piece

ASSEMBLY

- Use fastening kit to fasten to base frame
- Alternatively attach with mounting set **part no. 32.0806/0** to strut profiles of the base frame
- Also in ESD version **part no. 32.0812/6**
- Optionally available in different colors **part no. 32.0812/2**

DRAWER CABINET 100/100/100

Part no. 32.0813/0

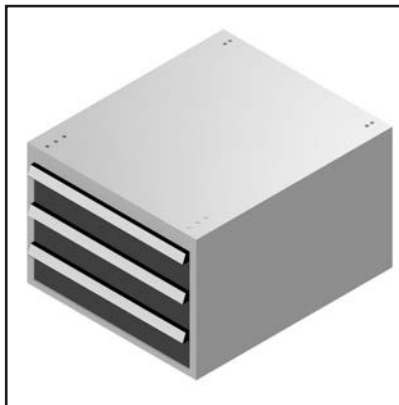
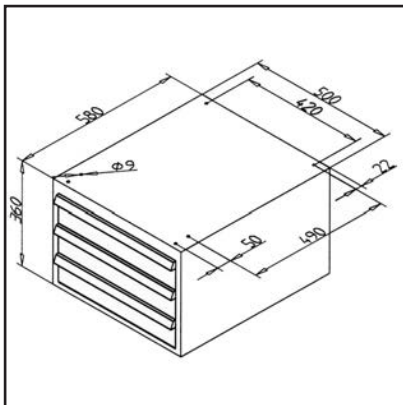

TECHN. DATA / ITEMS SUPPLIED

- Steel, lacquered
- With fastening material steel, zinc plated
- Color:
 - Corpus light grey RAL 7035
 - Drawer brilliant blue RAL 5007
- Cylinder lock with 2 keys, center locking for all drawers
- Individual drawer locking
- 3 drawers H = 100 mm, with perforated bottom
- Large handle bar with label adapter
- Can be pulled out up to 80 %
- Drawer inside W = 425 mm T = 550 mm, effective height = H-10 mm
- Max. load capacity per compartment 35kg
- Max. load capacity per cabinet: 200 kg
- Weight = 33.000 kg/piece

ASSEMBLY

- Use fastening kit to fasten to base frame
- Alternatively attach with mounting set **part no. 32.0806/0** to strut profiles of the base frame
- Also in ESD version **part no. 32.0813/6**
- Optionally available in different colors **part no. 32.0813/2**

DRAWER BASE CABINET 100/200/200

Part no.

32.0819/0

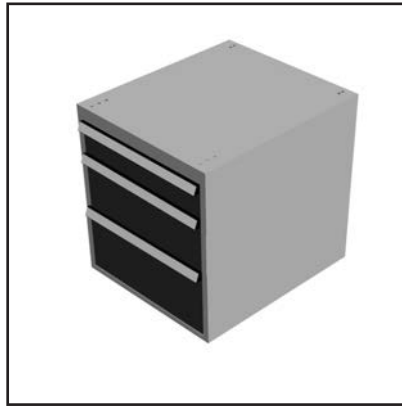
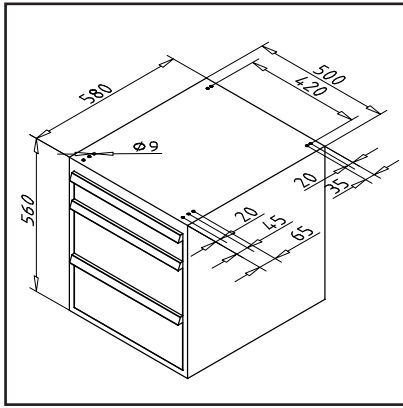
**TECHN. DATA / ITEMS SUPPLIED**

- Steel, lacquered
- With fastening material steel, zinc plated
- Color:
 - Corpus light grey RAL 7035
 - Drawer brilliant blue RAL 5007
- Cylinder lock with 2 keys, center locking for all drawers
- Individual drawer locking
- 1 drawer H = 100 mm, 2 drawers H = 200 mm, with perforated bottom
- Large handle bar with label adapter
- Can be pulled out up to 80 %
- Drawer inside W = 425 mm T = 550 mm, effective height = H-10 mm
- Max. load capacity per compartment 35kg
- Max. load capacity per cabinet: 200 kg
- Weight = 34.220 kg/piece

ASSEMBLY

- Use fastening kit to fasten to base frame
- Alternatively attach with mounting set **part no. 32.0806/0** to strut profiles of the base frame
- Also in ESD version **part no. 32.0819/6**
- Optionally available in different colors **part no. 32.0819/2**

DRAWER BASE CABINET 50/100/150/200

Part no.

32.0814/0

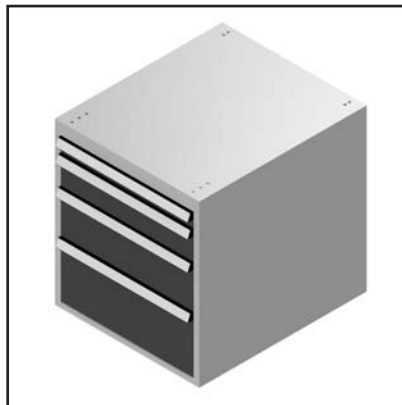
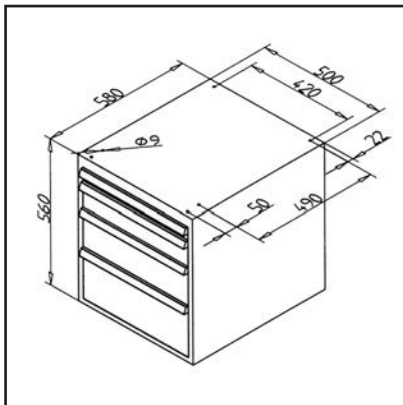
**TECHN. DATA / ITEMS SUPPLIED**

- Steel, lacquered
- With fastening material steel, zinc plated
- Color:
 - Corpus light grey RAL 7035
 - Drawer brilliant blue RAL 5007
- Cylinder lock with 2 keys, center locking for all drawers
- Individual drawer locking
- 1 drawer H = 50 mm, 1 drawer H = 100 mm, with perforated bottom
- Large handle bar with label adapter
- Can be pulled out up to 80 %
- Drawer inside W = 425 mm T = 550 mm, effective height = H-10 mm
- Max. load capacity per compartment 35kg
- Max. load capacity per cabinet: 200 kg
- Weight = 35.330 kg/piece

ASSEMBLY

- Use fastening kit to fasten to base frame
- Alternatively attach with mounting set **part no. 32.0806/0** to strut profiles of the base frame
- Also in ESD version **part no. 32.0814/6**
- Optionally available in different colors **part no. 32.0814/2**

DRAWER CONTAINER SET 1

Part no. 32.0807/0

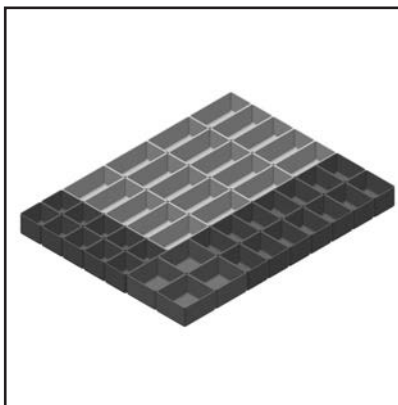
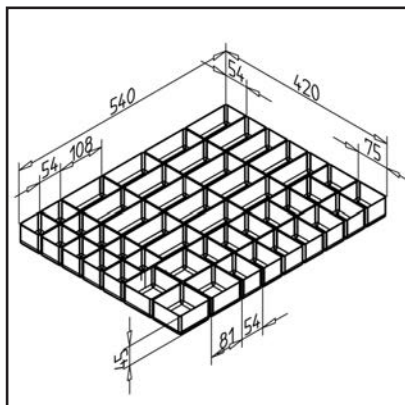

TECHN. DATA / ITEMS SUPPLIED

- B x T 425 x 550 mm
- For panel height 100-300 mm
- 20 x Container yellow 54 x 108 x 45 mm
- 14 x Container red 54 x 75 x 45 mm
- 10 x Container red 54 x 54 x 45 mm

- 4 x Container green 75 x 81 x 45 mm
- Other arrangements on request
- High impact polystyrene
- Weight = 1.060 kg/piece

ASSEMBLY

- Easy to remove and reinstall

DRAWER CONTAINER SET 2

Part no. 32.0808/0

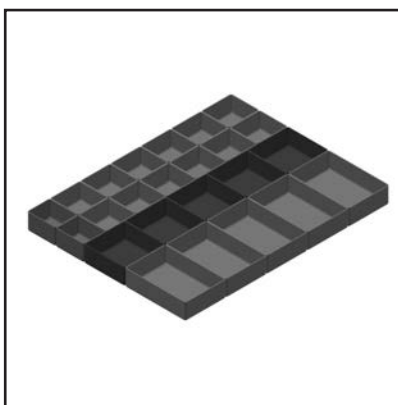
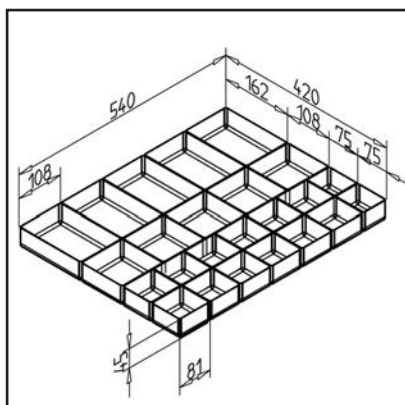

TECHN. DATA / ITEMS SUPPLIED

- B x T 425 x 550 mm
- For panel height 100-300 mm
- 12 x Container green 75 x 81 x 45 mm
- 5 x case 108 x 108 x 45 mm
- 5 x Container green 108 x 162 x 45 mm

- 2 x Container red 54 x 75 x 45 mm
- Other arrangements on request
- High impact polystyrene
- Weight = 0.965 kg/piece

ASSEMBLY

- Easy to remove and reinstall

DOORS BASE CABINET SMALL

Part no.

--...../-

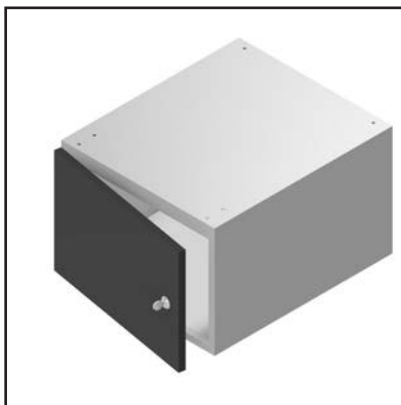
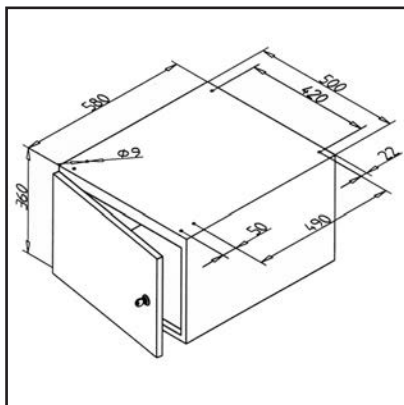
**TECHN. DATA / ITEMS SUPPLIED**

- Steel, lacquered
 - With fastening material steel, zinc plated
 - Color:
 - body light grey RAL 7035
 - door brilliant blue RAL 5007
 - Cylinder lock with 2 keys, 1 shelf
 - Max.load capacity per cabinet: 200 kg
- Left version (as shown) **part no. 32.0815/0**
 - Right version **part no. 32.0815/1**
 - Other colors:
 - left version under **part no. 32.0815/2**
 - Right version at **part no. 32.0815/3**
 - Weight = 34.000 kg/piece

ASSEMBLY

- Use fastening kit to fasten to base frame
- Alternatively attach with mounting set **part no. 32.0806/0** to strut profiles of the base frame

DOORS BASE CABINET LARGE

Part no.

--...../-

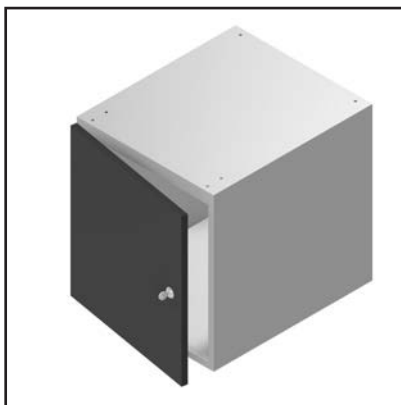
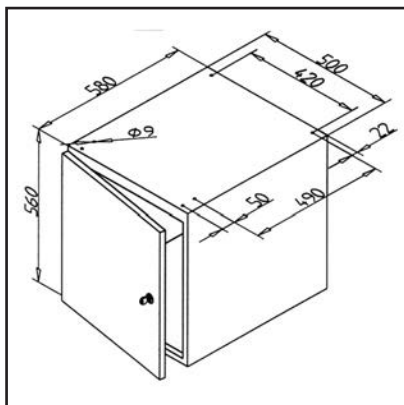
**TECHN. DATA / ITEMS SUPPLIED**

- Steel, lacquered
 - With fastening material steel, zinc plated
 - Color:
 - body light grey RAL 7035
 - door brilliant blue RAL 5007
 - Cylinder lock with 2 keys, 1 shelf
 - Max.load capacity per cabinet: 200 kg
- Left version (as shown) **part no. 32.0816/0**
 - Right version **part no. 32.0816/1**
 - Other colors:
 - left version under **part no. 32.0816/2**
 - Right-hand version at **part no. 32.0816/3**
 - Weight = 43.500 kg/piece

ASSEMBLY

- Use fastening kit to fasten to base frame
- Alternatively attach with mounting set **part no. 32.0806/0** to strut profiles of the base frame

TELESCOPIC GUIDE FULL EXTENSION 400

Part no.

32.0801/0

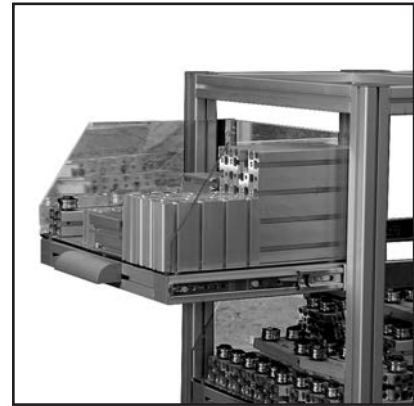
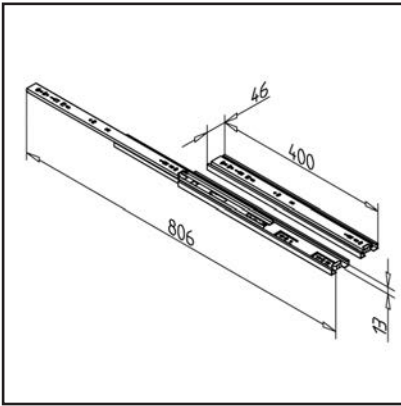

TECHN. DATA / ITEMS SUPPLIED

- Steel, galvanized
- with a self-closing feature
- Max. load capacity per compartment 35kg
- Mounting length 400 mm, pull-out length

406 mm

- **Other lengths on request**
- Items supplied: 2 pieces
- Weight = 1.225 kg/pair

ASSEMBLY

- Fasten to the side of drawers and profile

SYSTEM WORKPLACE LUMINAIRE LED-S | LED-M | LED-L

LED-S: Part no. **32.1160/0**LED-M: Part no. **32.1161/0**LED-L: Part no. **32.1162/0****PRODUCT DESCRIPTION**

- Compact and robust luminaire housing made of self-supporting aluminium profile, natural anodised
- Integrated mounting groove 30 (8 mm)
- Mains connection via 3 m supply cable with Schuko plug
- Integrated ON / OFF switch
- Very good glare protection thanks to micro prism screen plus additional diffuser foil. By turning the film, the reflected glare on high-gloss surfaces can be significantly reduced. The light distribution is softer, but the illuminance is reduced by about 14%.
- Profile end caps made of sheet steel grey, RAL 7012
- Absolutely flicker-free due to DC operation of the LEDs, extremely low-loss integrated electronic LED converter
- Complete with LED light-engine, neutral white (840) of the latest generation
- High luminous efficacy thanks to high-gloss anodised reflectors

PRODUCT ADVANTAGES

- Durable, virtually maintenance-free luminaire: LED life up to 50,000h
- High energy efficiency, approx. 25% more light with half energy consumption
- Smooth, easy to clean, closed construction
- Ready for mains voltage, no separate power supply

Technical Data LED**LED-S**

- Dimensions: 302 x 61 x 80 mm
- Protection: IP 20
- Protection class: I
- Supply voltage: 220-240V, 0/50...60 Hz
- Rated input current at 230 V: 0,045 A
- Lamp: 1 x LED light-engine à 8 W
- Total luminous flux (typical): 1400 lm, or 1000 LUX at 750 mm distance
- Light colour: 5000 K
- colour rendering (CRI): 1B (Ra >80)

LED-M

- Dimensions: 587 x 61 x 80 mm
- Protection: IP 20
- Protection class: I
- Supply voltage: 220-240 V, 0/50...60 Hz
- Rated input current at 230 V: 0,08 A
- Lamp: 1 x LED light-engine à 13,6 W
- Total luminous flux (typical): 2500 lm, or 1000 LUX at 1000 mmdistance
- light colour: 5000 K
- colour rendering (CRI): 1B (Ra >80)

LED-L

- Dimensions: 872 x 61 x 80 mm
- Protection: IP 20
- Protection class: I
- Supply voltage: 220-240 V, 0/50...60 Hz
- Rated input current at 230 V: 0,1 A
- Lamp: 2 x LED light-engine à 20,4 W gesamt
- Total luminous flux (typical): 3800 lm, or 1350 LUX at 1000 mm distance
- light colour: 5000 K
- colour rendering (CRI): 1B (Ra >80)

STANDARDS AND GUIDELINES

The product complies with the European standards for electrical luminaires, DIN EN 60598 (VDE 0711) and the European standards for electromagnetic compatibility EN 55015, EN 61547, EN 61000-3-2 and thus the EU low-voltage and EU EMC Directive.

INSTALLATION AND OPERATING INSTRUCTIONS

LED-S / M: max.28 lights on a circuit breaker C13.
LED-L: max.22 lights on a circuit breaker C13

ITEMS SUPPLIED

- Luminaire with 3m supply cable and Schuko plug
- Without fastening kit



System workplace luminaire available in different lengths

SYSTEM WORKPLACE LUMINAIRE LED-M / LED-L - DIMMABLE

Dimmable via lamp switch
 LED-M: Part no. **32.1163/0**
 LED-L: Part no. **32.1165/0**

PRODUCT ADVANTAGES

- Durable, virtually maintenance-free luminaire:
- LED-Lifespan up to 50.000 h
- Smooth, easy to clean, closed construction
- Ready for mains voltage, no separate power supply
- SwitchDIM-Function: infinitely dimmable by integrated or external button, the dimming process adapted to the eye sensitivity
- Memory function: Lamp starts after switching back on in last dimming position

SYSTEM WORKPLACE LUMINAIRE LED-M DIMMABLE

- Dimensions: 587 x 61 x 80 mm
- Protection class: IP 20
- Protection class: I
- Supply voltage: 220-240 V, 0/50...60 Hz
- Nominal input current at 230 V: approx.. 0,1 A
- Bulb: 1 x LED light-engine à 16 W
- Total luminous flux (typical): 2800 lm, resp. 1100 LUX at 1000 mm distance
- Light color: neutral white 5000 K (840)
- Color rendering (CRI): 1B (Ra >80)
- Dimming: 1 - 100%

FASTENING OPTIONS



Fastening kit
 system workplace luminaire PA
 Part no. 32.1130/0



Fastening kit system work-
 place luminaire angle adjust-
 able
 Part no. 32.1131/0



Fastening kit
 system workplace luminaire steel
 part no. 32.1132/0

Dimmable via external push-button LED-M:
 Part no. **32.1164/0**
 LED-L: Part no. **32.1166/0**

INSTALLATION AND OPERATING INSTRUCTIONS

- Operate max. 20 lights on one circuit breaker C13 (max 10 pcs / B13).

ITEMS SUPPLIED

- Luminaire with 3m supply cable and Schuko plug with internal
- Luminaire with 4m supply cable without plug with external
- Without fastening material

SYSTEM WORKPLACE LUMINAIRE LED-L DIMMABLE

- Dimensions: 872 x 61 x 80 mm
- Protection class: IP 20
- Protection class: I
- Supply voltage: 220-240 V, 0/50...60 Hz
- Nominal input current at 230 V: approx. 0,13 A
- Bulb: 2 x LED light-engine à 24 W
- Total luminous flux (typical): 4250 lm, resp. 1500 LUX at 1000 mm distance
- Light color: neutral white 5000 K (840)
- Color rendering: (CRI): 1B (Ra >80)
- Dimming: 1 - 100%

PROFILE LUMINAIRE LUCIDUS

Profile luminaire S Part no. **32.1169/0**

Profile luminaire M Part no. **32.1170/0**

Profile luminaire L Part no. **32.1171/0**



– Luminaire embedded in the profile

Product description

- The profile luminaire Lucidus optimally illuminates the work area. At the workbench, at machines, at home, in the office and in many other places.
- Profile light dimensions suitable for MiniTec profile 45 x 45
- Can be integrated into MiniTec frame constructions
- Load capacity according to MiniTec profile
- Standard lengths 446 mm, 646 mm and 1016 mm, also special lengths available
- High luminosity
- Built-in power supply unit, electrical connection on site via terminals
- The luminaire can also be dimmed via a separate 0-10V control line
- IP68 waterproof design (outdoor) possible
- Flicker-free light without UV / IR component
- Colour rendering index RA (CRI): 83
- Suitable for manual workplaces, exhibition stands, machines, milling machines, lathes, designer lamps, advertising lighting, trade fair technology

PRODUCT ADVANTAGES

- Can be used directly as a profile
- Fastening possible with all fastening elements from the MiniTec modular profile system
- Durable, virtually maintenance-free luminaire: LED service life up to 50000 hours
- High energy efficiency
- Slightly dimmable
- Special lengths available

Specifications

EN55015:2006, EN61000 and EN61547:2009

Items supplied

- Luminaires in respective length, with attached power supply.
- The luminaires can also be supplied dimmable on request

PROFILE LUMINAIRE LUCIDUS

Profile plate for profile luminaire,
Fastening possible with all fastening elements from the MiniTec profile construction kit.

FASTENING OPTIONS



Lateral bracket
height adjustable/rotatable



Upper bracket
adjustable/rotatable

TECHNICAL DATA

TYPE	Profilleuchte S L=446mm	Profilleuchte M L=646mm	Profilleuchte L L=1016mm
Part no.	32.1169/0	32.1170/0	32.1171/0
Total length in mm	446	646	1016
Illuminated length in mm	430	630	1000
Illuminated width in mm	40	40	40
Luminaire profile width in mm	45	45	45
Luminaire profile height in mm	45	45	45
Mounting groove (top side) in mm	8	8	8
Lamp	SMD LED	SMD LED	SMD LED
Supply voltage	240 V	240 V	240 V
Power in W	30	40	60
Illuminance in lx (at 1000 mm distance)	3200	4600	7300
colour temperature SMD LED in K	approx. 6000 (daylight white)	approx. 6000 (daylight white)	approx. 6000 (daylight white)
Expected life in hours	> 50000	> 50000	> 50000

ENERGY SUPPLY



The MiniTec power supply duct for electrics and compressed air for the individual arrangement of the installation elements of the power supply: Exactly equipped according to your needs and completely wired cable ducts simplify the installation of your workplace considerably. Our experienced specialists take over the assembly for you. The cable channel with 4 m supply line is equipped for immediate connection with Schuko or CEE plug. The installation by certified electricians in your house will be eliminated.

With the cable channel we have equipped and installed, you will receive a meaningful test certificate. The cable duct and the cover are made of aluminum, natural anodised. Only high-quality

branded products are used as built-in elements. The following overview simplifies the definition of the equipment you require. Subsequent installation of other elements is possible at any time by an authorized electrician.

CABLE DUCT 130 AL**Part no. 32.0715/0**

Manufacturing length 6m, power supply of sockets, switches, telecommunication connections, circuit breakers etc.

COVER FOR CABLE DUCT 130**Part no. 32.0716/0**

Manufacturing length 6m, Press cover on cable duct

END CAP FOR CABLE DUCT 130**Part no. 32.0717/0**

Plastic molding, painted aluminum color

ASSEMBLY ENERGY SUPPLY DUCT

KEY SWITCH Part no. 32.0720/0

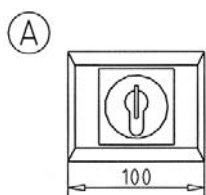

- 16 A, 2-pole

SWITCH Part no. 32.0725/0

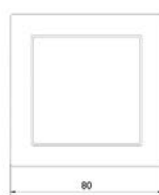

- 16 A, 1 -pin

OVERVOLTAGE PROTECTION Part no. 32.0721/0

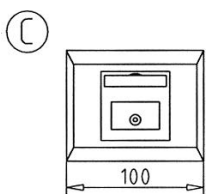

- UN = 230V AC

DATA PORT CAT6 Part no. 32.0729/0

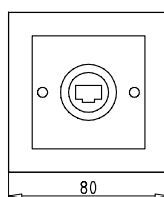

- RJ 45. link E, up to 250 MHz
- Complete junction box with output socket and frame for installation in cable duct

CHANNEL SOCKET Part no. 32.0723/0

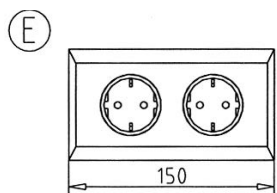

- With earthing contact according to DIN

SOCKET CEE 16A Part no. 32.0724/0

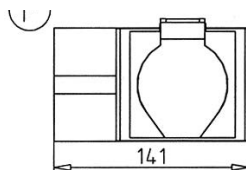

- for plug DIN, 5-pin, 16 A
- Machine installation unit with 3 PLE
- Complete with mounting plate
- Can be equipped with automatic circuit breaker C10 with 1 PLE
- Automatic circuit breaker C 13 with 1 PLE
- Residual current device 1-pole 16A / 30mA with 2 PLE

INSTALLATION DISTRIBUTION Part no. 32.0730/0

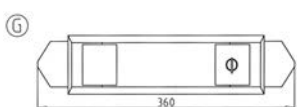

PNEUMATICS SIMPLE Part no. 32.0740/0



PNEUMATICS DOUBLE Part no. 32.0741/0



EQUIPMENT

In the day-to-day life it is the small things that matter. Practical accessories are the necessary supplement to the perfect design of an optimal workplace. Everything must have its place, instructions or information must be clean and visible. Additional

devices that avoid stress and provide an overview in the workplace help to noticeably increase efficiency while reducing the workload of employees.

SYSTEM WORKSTATION COMPONENTS

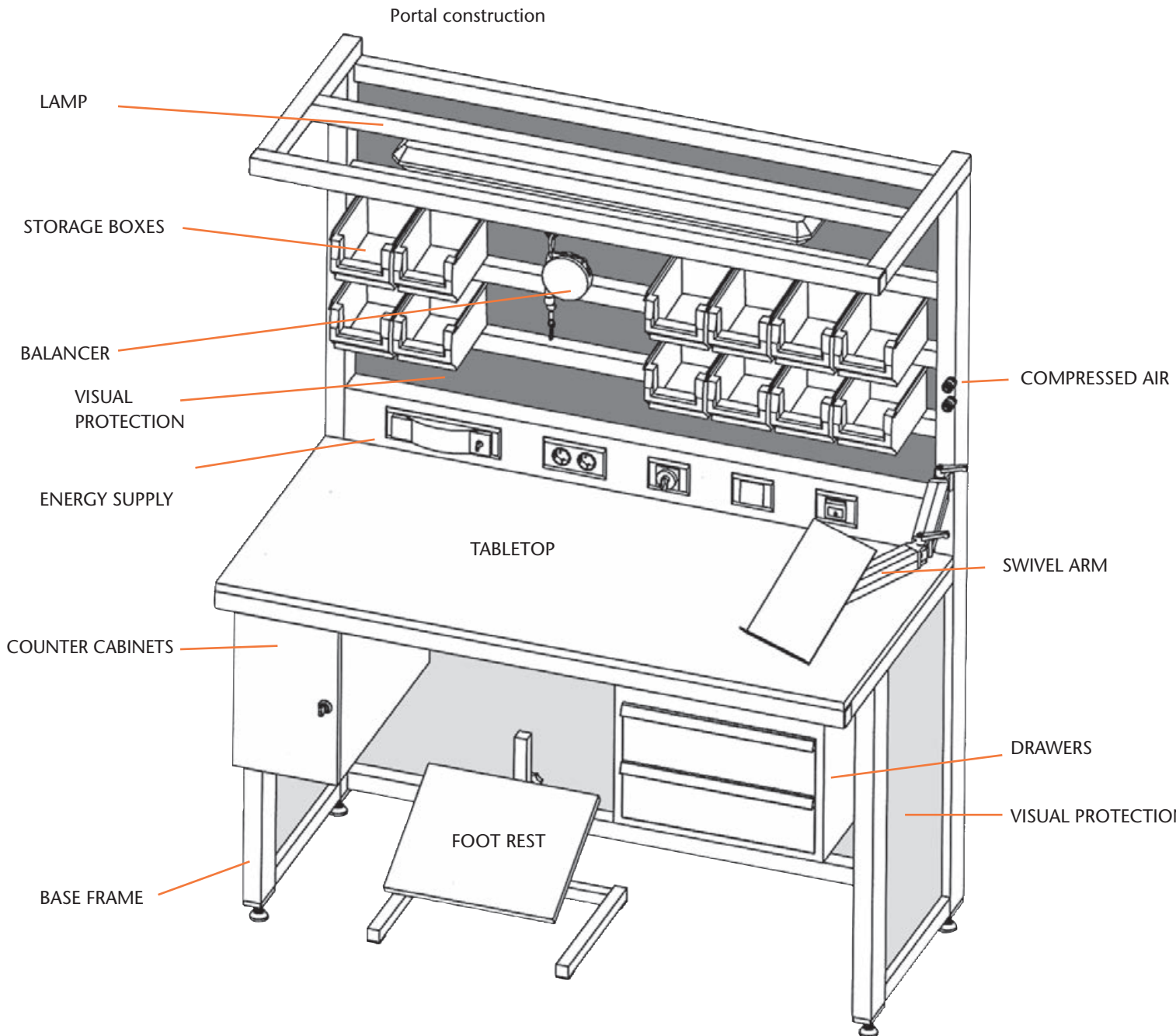

EQUIPMENT

■ For overview and order in the workplace

With the MiniTec assortment of tool holder plates, tool carriers and various tool holders, you can create an overview and order at your workplace. With this program, the operator has the right holder for every tool.

Tool holder plates

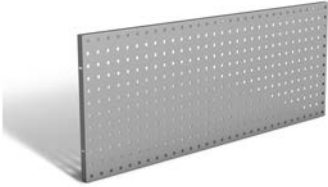
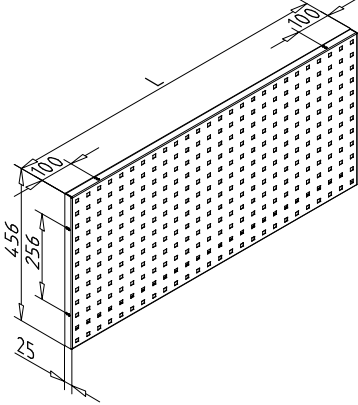
		Tool holder plates	
		Size 500:	L = 494 mm
		Part No.	32.0660/0
		Size 1000:	L = 988 mm
		Part No.	32.0665/0
		Size 1200:	L = 1178 mm
		Part No.	32.0670/0
		Size 1500:	L = 1482 mm
		Part No.	32.0675/0
		Size 2000:	L = 1976 mm
		Part No.	32.0680/0

- Steel, powder coated, grey, RAL 7035
- ESD capability
- Is simply attached to the portal structure
- Square perforation 10 x 10mm in grid 38mm

Tool carrier with double-joint swivel arm

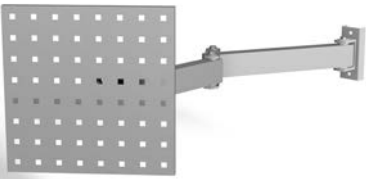
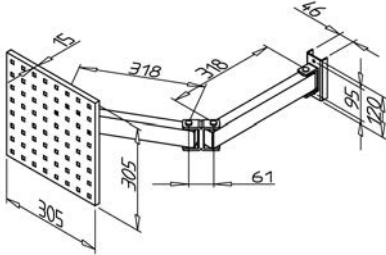

		Tool carrier with double joint swivel arm	
		Part no.	32.0510/0
		ESD tool carrier with double joint swivel arm	
		Part no.	32.0510/6

- Steel, painted light grey, RAL 7035
- Capacity 150 N
- Is simply attached to the portal structure
- Square perforation 10 x 10mm in grid 38mm





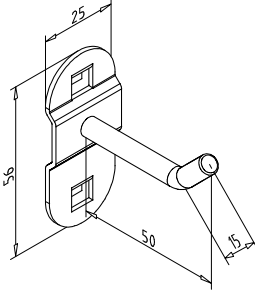
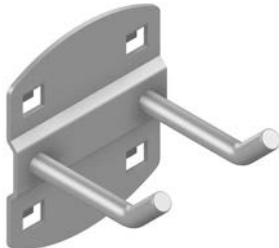
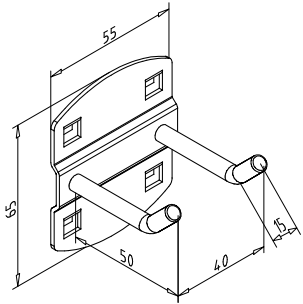
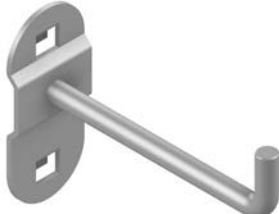
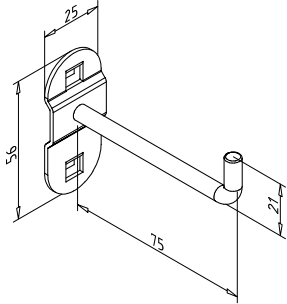

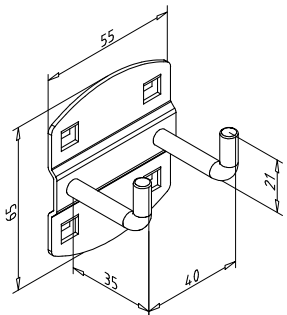
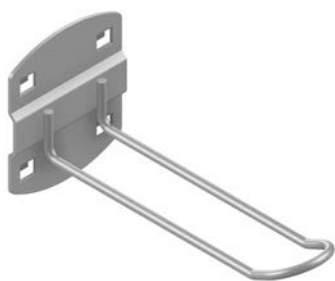
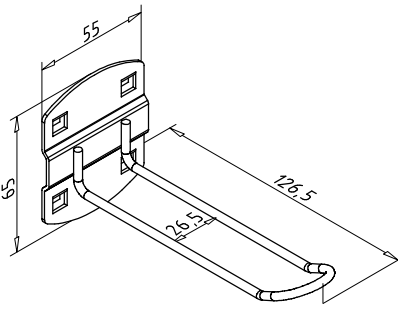
EQUIPMENT

The aluminum-colored tool holders have a shock- and scratch-resistant plastic coating and a 1.5mm thick, embossed base plate. The holders are matched to the tool holder plates and the tool carrier.

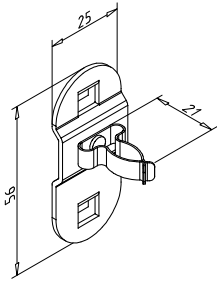
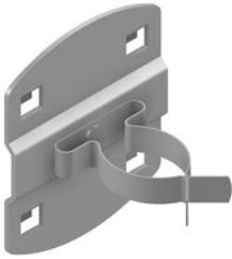
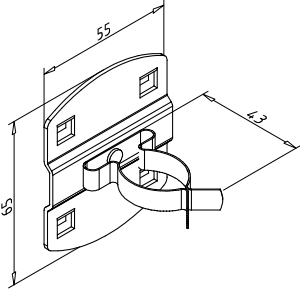

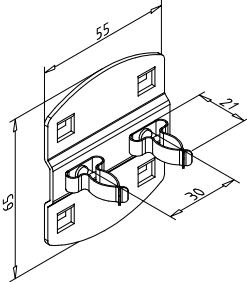

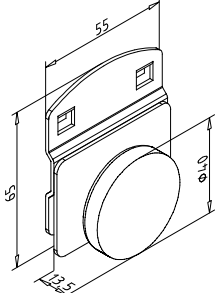

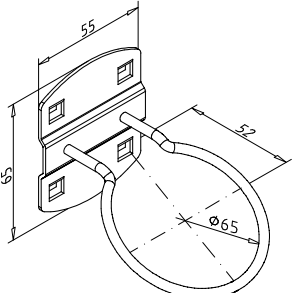
All products are also available in ESD version on request.

		<p>Tool holder with angled hook end</p> <p>Hook Ø 6,3 mm</p> <p>L= 50mm Part No. 32.0527/0</p> <p>L=100mm Part No. 32.0651/0</p>
		<p>Double tool holder with inclined hook end</p> <p>Hook Ø 6,3 mm</p> <p>L= 50mm Part No. 32.0653/0</p> <p>L= 75mm Part No. 32.0654/0</p>
		<p>Tool holder with vertical hook end</p> <p>Hook Ø 6,3 mm</p> <p>L= 75mm Part No. 32.0652/0</p>
		<p>Double tool holder with vertical hook end</p> <p>Hook Ø 6,3 mm</p> <p>L= 35mm Part No. 32.0508/0</p> <p>L= 50mm Part No. 32.0655/0</p> <p>L= 75mm Part No. 32.0656/0</p>
		<p>Tool holder for self-service packaging</p> <p>Hanger Ø 3,7 mm</p> <p>L= 125mm, W= 30mm Part No. 32.0658/0</p>

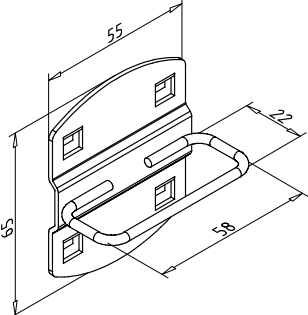

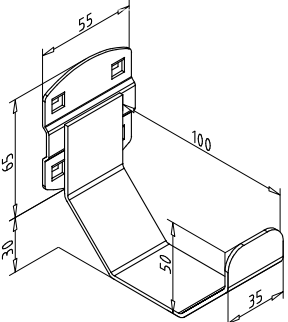

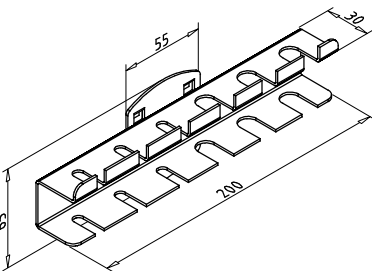
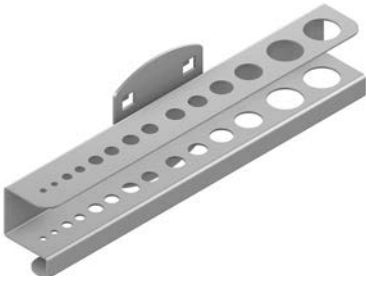
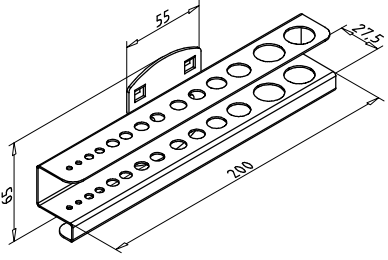

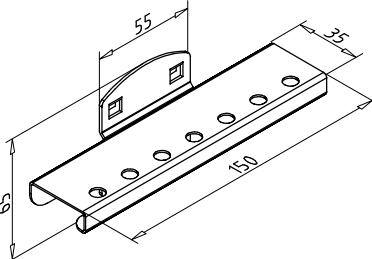
EQUIPMENT

		<p>Tool clamp simple, small base plate</p> <p>For clamping tools with \varnothing 7-10 mm</p> <p>Part No. 32.0529/0</p>
		<p>Tool clamp simple, large base plate</p> <p>For clamping tools with \varnothing 20-25 mm</p> <p>Part No. 32.0528/0</p>
		<p>Double tool clamp</p> <p>For clamping tools with \varnothing 7-10 mm</p> <p>Part No. 32.0506/0</p>
		<p>Magnetic holder</p> <p>Holding force approx. 5 kg</p> <p>Part No. 32.0515/0</p>
		<p>Machine holder</p> <p>For tools up to \varnothing 60 mm</p> <p>Part No. 32.0657/0</p>

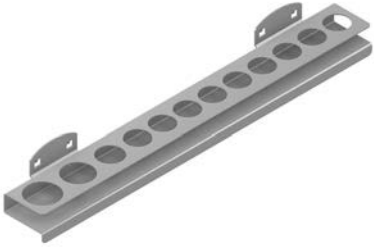
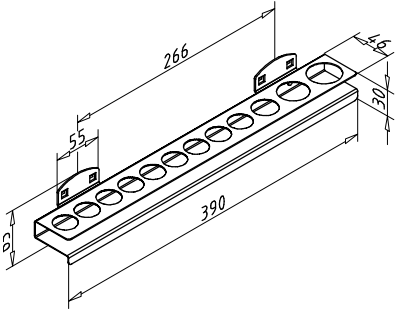
EQUIPMENT

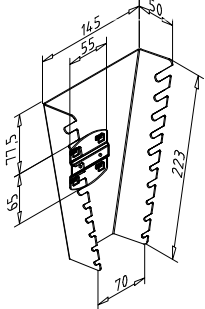
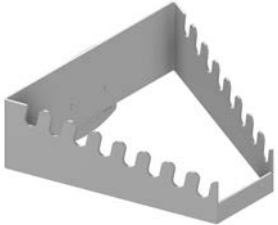
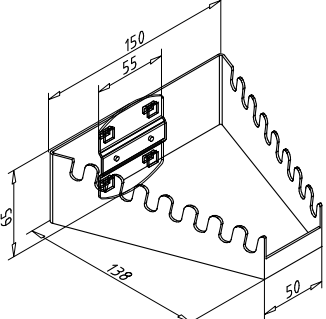
		<p>Chuck holder</p> <p>For tools with a cross section of up to 54 x 19 mm</p> <p>Part No. 32.0531/0</p>
		<p>Pipe holder, also for hoses, cables etc.</p> <p>For hoses and cables up to 100 mm in diameter</p> <p>Part No. 32.0564/0</p>
		<p>Screwdriver holder for 6 parts</p> <p>3 receiving slots 6.5 mm wide and 23 mm deep 3 receiving slots 12.5 mm wide and 23 mm deep</p> <p>Part No. 32.0649/0</p>
		<p>Drill / hex socket holder, for 14 parts</p> <p>Mounting holes</p> <ul style="list-style-type: none"> 2 x Ø 3,2 mm 2 x Ø 4,7 mm 2 x Ø 6,7 mm 2 x Ø 7,7 mm 2 x Ø 8,7 mm 1 x Ø 10,7 mm 1 x Ø 12,7 mm 2 x Ø 16,7 mm <p>Part No. 32.0504/0</p>
		<p>Bit holder for 7 bits</p> <p>Mounting holes 7x Ø 7,2 mm</p> <p>Part No. 32.0503/0</p>

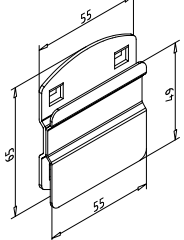
EQUIPMENT

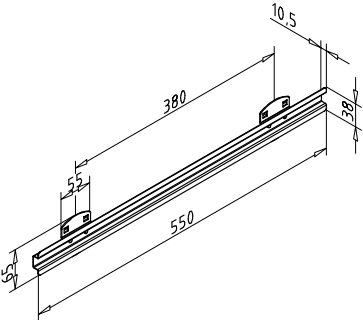
		<p>Nut holder for 12 nuts</p> <p>Mounting holes</p> <p>9 x Ø 24,7 mm 1 x Ø 27,3 mm 1 x Ø 31,7 mm 1 x Ø 34,7 mm</p> <p>Part No. 32.0519/0</p>
		<p>Wrench holder vertical for 10 keys</p> <p>Receiving slots</p> <p>1 x 7,5 x 30 mm 2 x 6,5 x 23 mm 2 x 5,5 x 20 mm 2 x 4,5 x 15 mm 3 x 4,0 x 10 mm</p> <p>Part No. 32.0521/0</p>
		<p>Wrench holder horizontally for 8 keys</p> <p>8 receiving slots 6.5 x 15 mm</p> <p>Part No. 32.0523/0</p>
		<p>View storage boxes for 1 box size 7 and 8</p> <p>Max. material thickness for hanging 4 mm</p> <p>B= 55mm Part No. 32.0509/0</p>
		<p>View storage boxes for 5 boxes up to size 8</p> <p>L= 550mm, H= 38mm Part No. 32.0532/0</p>

EQUIPMENT

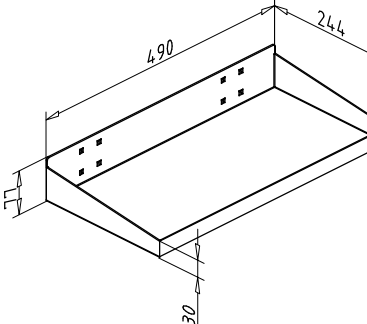
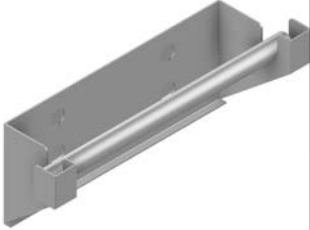
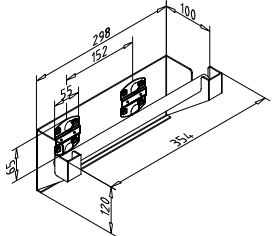
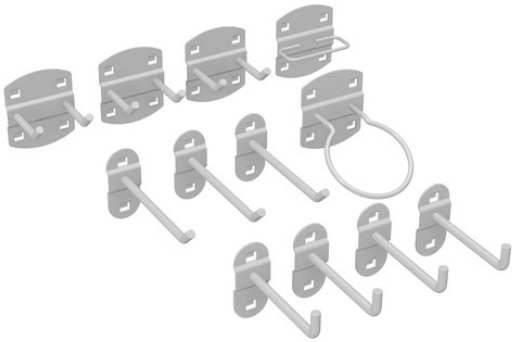
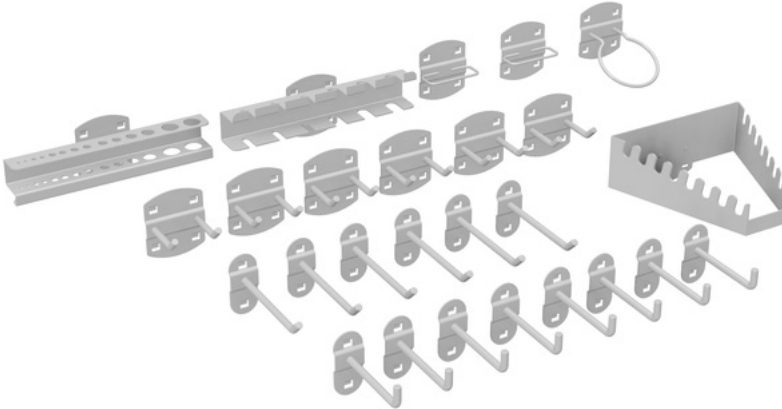
		<p>Steel floor with roll-off edge</p> <p>W= 490mm, D= 243mm Part No. 32.0659/0</p>
		<p>Dispensers</p> <p>Roller axis Ø 22 mm Distance between roller axis and rear wall approx. 50 mm</p> <p>Part No. 32.0611/0</p>
	<p>Tool holder assortment, 12 pieces Part no. 32.0607/0 consisting of:</p> <p>4 x Toolholder Part No. 32.0652/0</p> <p>3 x Toolholder Part No. 32.0651/0</p> <p>3 x Double tool holder Part No. 32.0653/0</p> <p>1 x Machine holder Part No. 32.0657/0</p> <p>1 x Chuck holder Part No. 32.0531/0</p>	
	<p>Tool holder assortment, 26 pieces Part no. 32.0606/0 consisting of:</p> <p>8 x Toolholder Part No. 32.0652/0</p> <p>6 x Toolholder Part No. 32.0651/0</p> <p>6 x Double tool holder Part No. 32.0653/0</p> <p>1 x Machine holder Part No. 32.0657/0</p> <p>2 x Chuck holder Part No. 32.0531/0</p> <p>1 x Screwdriver holders Part No. 32.0523/0</p> <p>1 x Drill / hex socket holder Part No. 32.0504/0</p> <p>1 x Screwdriver holders Part No. 32.0649/0</p>	

UNIVERSAL HOLDER

Part no.

22.1175/0

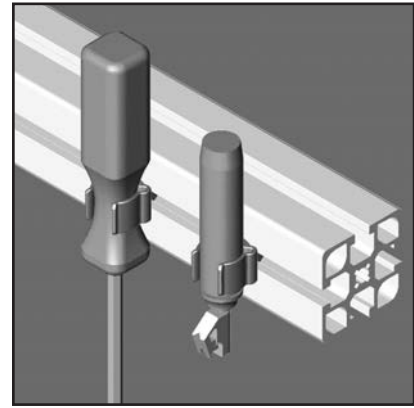
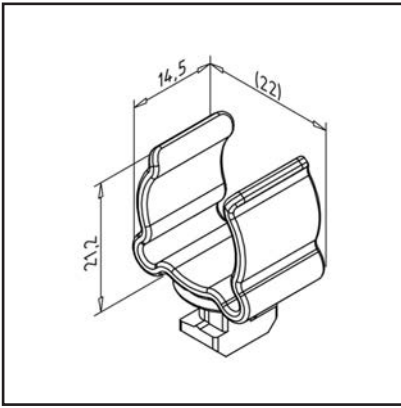

TECHN. DATA / ITEMS SUPPLIED

- PA, grey
- Polyamide, grey
- Weight = 0.003 kg/piece

APPLICATIONS

- Holding for all kinds of worktools
- Tools with a diameter of ca. 15 - 21 mm
- Max. weight 160 g

ASSEMBLY

- Insert in profile groove and turn 90°

MAGNET 6 X 14 X 50

Part no.

21.0032/0

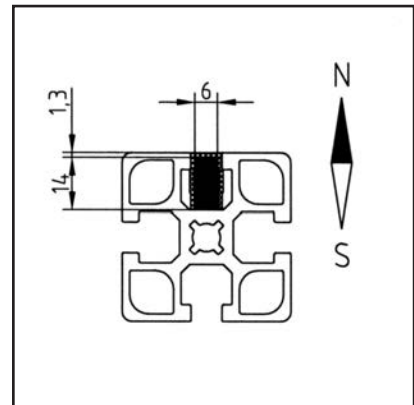
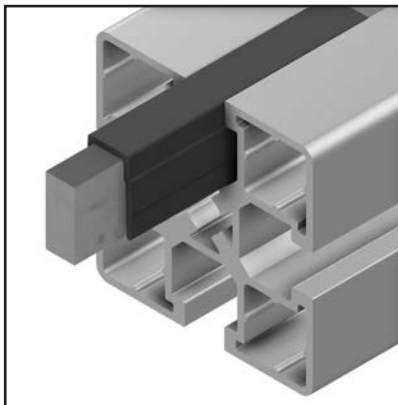
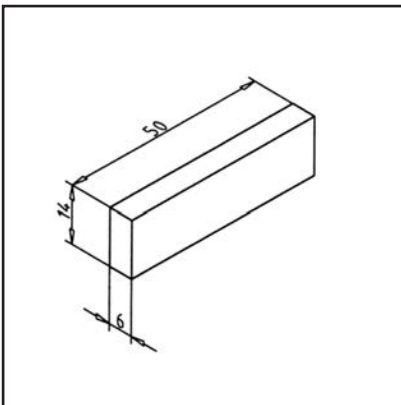

TECHN. DATA / ITEMS SUPPLIED

- NeFeB N35, nickel-plated
- Without fastening kit
- Attention: Electric- and memory devices can be faulted by the magnet
- Power density, $BH_{mx} = 263 \text{ kJ/m}^3$
- Remanence, $B_r = 1170 \text{ mT}$
- coercive field strength $H_{cj} = 955 \text{ kA/m}$
- max. service temperature $+80 \text{ }^\circ\text{C}$
- Weight = 0.030 kg/piece

APPLICATIONS

- Adhesive magnet for tools
- Use under conveyor belts as tracking, for magnetizable conveying products or at higher conveying speeds
- Fitting for all profiles of profile series 45

ASSEMBLY

- Snap or slip the cover profile into profile groove
- Insert magnet into t-slot
- For fastening: (mighty recommended) Use end cap AL, set screw with square nut or t-slot bar

MAGNET 6 X 9 X 50 MM

Part no.

21.0040/0

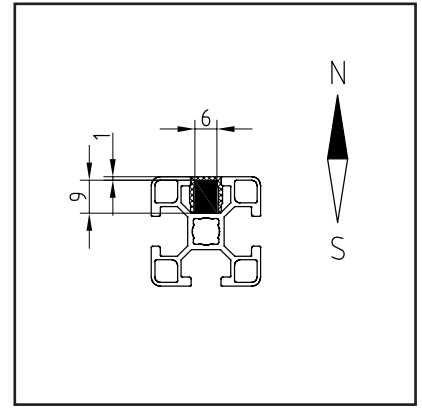
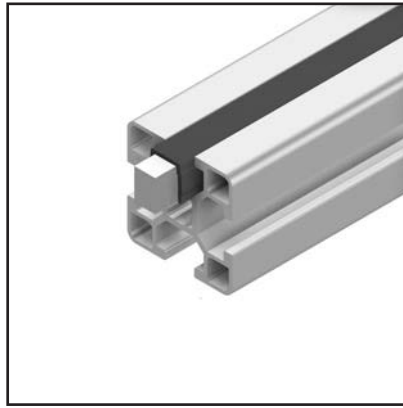
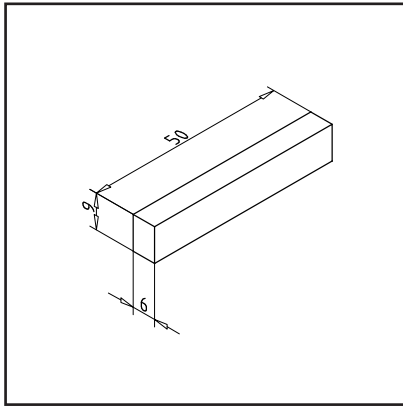
**TECHN. DATA / ITEMS SUPPLIED**

- NeFeB N45, nickel-plated
- Without fastening kit
- Attention: Electric- and memory devices can be faulted by the magnet
- Power density, $BH_{mx} = 342 \text{ kJ/m}^3$
- Remanence, $B_r = 1320 \text{ mT}$
- coercive field strength $H_{cj} = 955 \text{ kA/m}$
- max. service temperature $+80 \text{ }^\circ\text{C}$
- Weight = 0.023 kg/piece

APPLICATIONS

- Adhesive magnet for tools
- Use under conveyor belts as tracking, for magnetizable conveying products or at higher conveying speeds
- Fitting for all profiles of profile series 30

ASSEMBLY

- Snap or slip the cover profile into profile groove
- Insert magnet into t-slot
- For fastening: (might recommended) Use end cap AL, set screw with square nut or t-slot bar

STORAGE BOXES

Type 1

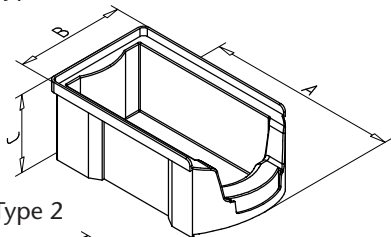

Type 2

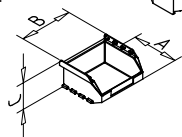

TECHNICAL DATA

- Optimal overview and convenient access to the content
- Large handles on the front and back for easy handling
- Dimensionally stable
- Resistant to most acids and oils
- temperature resistance (-20° to +80°C)

APPLICATION

- Provision of small parts, screws, nuts etc. at assembly workstations
- Ergonomic workplace systems

ASSEMBLY

- Mount storage boxes with storage box holder, 1-fold part no. 32.0509/0 or with multiple storage box holder part no. 32.0532/0 on tool holder plate or carrier

Type	Part no.	Measure A	Measure B	Dimension C	Color
1	32.0540/0	360	210	147	blue
	32.0540/5	350	200	145	black ESD
1	32.0541/0	229	148	122	blue
	32.0541/5	235	145	125	black ESD
1	32.0542/0	167	104	76	blue
	32.0542/5	175	100	75	black ESD
2	32.0543/0	85	100	50	blue
	32.0543/5	95	100	50	black ESD

STORAGE BOX SHELF

Part no.

32.0514/0

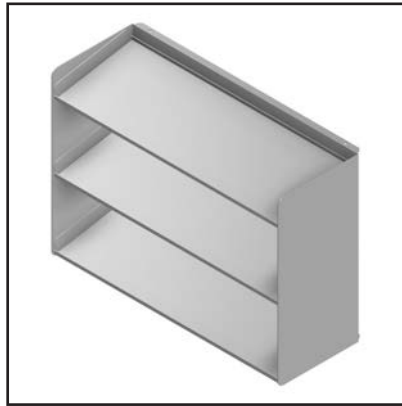
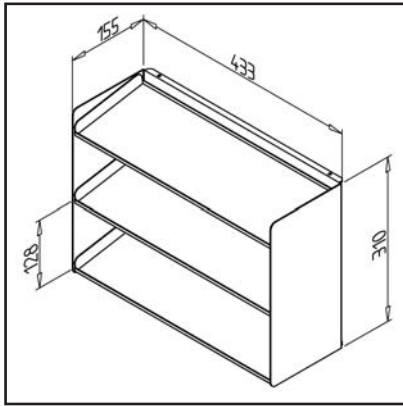
**TECHN. DATA / ITEMS SUPPLIED**

- Steel, powder-coated, grey
- 3 levels
- Weight = 3.800 kg/piece

APPLICATIONS

- For semi open front containers and small hardware
- For max. 12 semi open front containers, L= 165 mm, W= 105 mm, H= 75 mm

ASSEMBLY

- Fasten to the portal structure
- Freestanding or in combination with box holder **part no. 32.0516/0** swiveling
- Optional: in ESD-design **part no. 32.0514/6**

STORAGE BOX HOLDER

Part no.

32.0516/0

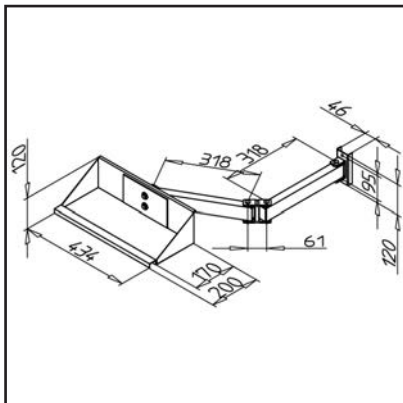
**TECHN. DATA / ITEMS SUPPLIED**

- Steel, powder-coated, grey
- Fastening material
- Front handle bar
- With double articulated arm 700 mm long
- Load capacity 150 N
- Weight = 4.300 kg/piece

APPLICATIONS

- As storage area for semi open front containers and semi open front container racks

ASSEMBLY

- Installation on the vertical strut of the portal structure
- Optional: in ESD-design **part no. 32.0516/6**

KANTAINER

The newly developed KanTainer offers the ideal prerequisite for implementing the principles of lean production in your company using Kanban control.



In combination with the mounting solutions and the ergonomic designed working places of MiniTec, a complete, safe and economic all-round-package for your manual production is ensured. The Kantainer is designed for maximum space utilization in the warehouse with optimal material provision at the workplace. The Kantainer offers all the prerequisites to make

storage, order picking and assembly easier and safer. Thanks to the compatible system components of our extensive MiniTec modular system, we are able to optimally solve virtually every task in manual assembly.

FUNCTIONS

- For continuous kanban system: no transfer - no error-prone refilling
- Total storage rack use by retractable grip plate
- Ergonomically optimized grip plate eases the removal
- Transparent cover against soiling and mixing of parts
- Cover as protection against unintentional opening or loss of parts
- Simple content control
- Transparent dosing disc: easy recognition of residual quantities
- Dosing disc prevents uncontrolled trickling out of small parts
- Secure stacking through locating pins and eyelets
- Double-sided labelling
- Retaining device at the back of the container
- Bottom guide rails for longitudinal and transverse transport

TECHNICAL DATA

- Dimensions: 175x126x88 [mm]
- Superimposed load 50 kg
- Content load: 5 kg
- Temperature resistance: -20°C to +90°C
- Material: polypropylene, polystyrene
- Color:
 - Basalt grey (RAL 7012) [Part no.: 32.0870/0]
 - Orange (RAL 2004) [Part no.: 32.0870/1]
 - Black ESD conductive [Part no.: 32.0870/5]

The ESD-conductive Kantainer is the optimal and logical addition to our ESD workstation systems.



KANTAINER-SWIVEL CANTILEVER, 3-FOLD

Part no.

32.0877/0

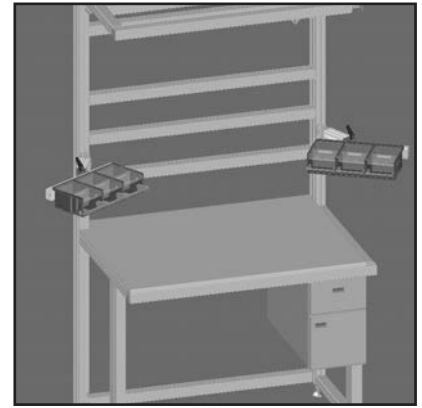
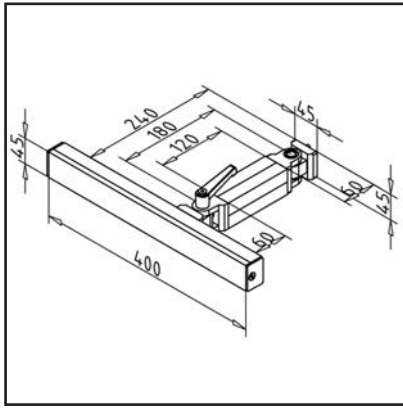
**TECHN. DATA / ITEMS SUPPLIED**

- Profile 45 x 32 F and 45 x 45 F
- heavy duty joint and swivel joint with clamping lever with supplied hardware
- Load capacity: max.= 100 N
- Weight = 1.916 kg/piece

APPLICATIONS

- Accepting 3 KanTainers

ASSEMBLY

- Mount the heavy load hinge on the table

KANTAINER - SHELF (STRAIGHT)

Part no.

32.0876/0

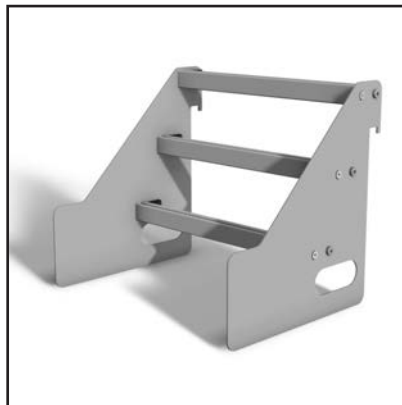
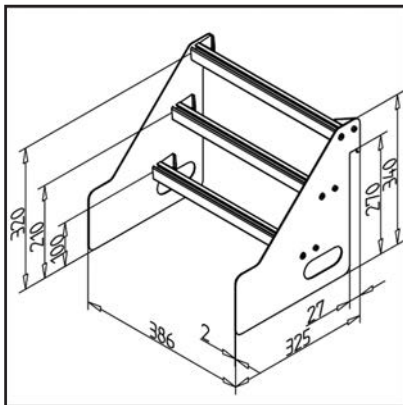
**TECHN. DATA / ITEMS SUPPLIED**

- Side panels steel, powder coated, grey
- Intermediate struts of profile 23 x 30
- Delivery as construction set
- Fastening kit
- Weight = 3.400 kg/piece

APPLICATIONS

- Accepting 9 KanTainers
- Adjustable inclination
- With the hooks on the back, the shelf can also be hung in our profile grooves

ASSEMBLY

- Screw profiles to side panels with supplied mounting angles and mounting hardware

MONITOR SUPPORT LX AND LX HD







APPLICATION

The LX and LX HD monitor supports are suitable for a wide range of applications: suitable for large monitors, medium-sized televisions and all-in-one computers weighing up to 13.6 kg. The LX offers a large range of motion and is suitable for both sedentary and standing users, allows vertical adjustment of up to 51 cm and lateral adjustment of 157 cm.

ADVANTAGES

- More freedom and flexibility through maximum ergonomic comfort
- Maximum comfort when positioning the monitor
- Integrated cable management
- Up to 51 cm stepless height adjustment, meets the ergonomic principles of more than 90% of all users
- Arm can be pulled back over the base plate and fold up; suitable for storage in shelves or cupboards in confined spaces
- Outstanding viewing comfort prevents health risks in the neck and back
- LCD range up to 88 cm. Simply slide the screen to the side if you are not using it

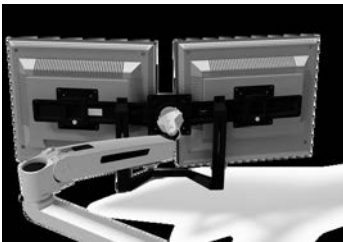
		
	LX HD arm for wall mounting	LX arm for wall mounting
Part No.	32.0623/0	32.0622/0
Scope of delivery	LX HD sit-stand-arm, extension, wall mounting base, VESA brackets incl. mounting material	LX LCD-arm, bracket arms, wall bracket base. Direct mounting on solid vertical surfaces incl. mounting material
Maximum screen size	46"	24"
Screen size may vary. Details refer to the screen diagonal.		
Load-bearing capacity	6,3–13,6 kg	3.2-9.1 kg monitor depth can be greater than 5 cm reduce capacity
Height adjustment	51 cm	33 cm
Tilt function	80° 75° / 5°	75° 70° / 5°
Swivel function	360°	360°
Rotation	90° Rotation with portrait / landscape mode	90° Rotation with portrait / landscape mode
VESA	75x75mm/100x100mm/200x100mm/200x200mm	75x75mm/100x100mm
Depth	Foldable to 12 cm	Foldable to 13.4 cm
Reach up	84 cm	64 cm
Transport weight	9,1 kg	3,2 kg
Transport dimensions	64 x 38 x 19 cm	53 x 29 x 19 cm
ACCESSORIES		
32.0612/0	Keyboard tray	
	Keyboard shelf made of sheet steel, powder-coated matt black for mounting on monitor carrier LX / LX HD. Rear cable entry for mouse and keyboard. The distance to the monitor is adjustable. For fastening the existing VESA holes are used. When used, the arm is additionally loaded with 2.4kg.	
32.0624/0	Monitor handle Kit	
	Can be attached to many mounts using a bolt circle of 50 x 50mm, 100 x 100mm or 200 x 100mm. Robust design ensures long service life. Suitable for displays up to a size of 32 inches. When used, the arm is additionally loaded with 1.3 kg.	
39.0118/0	Dual monitor support for LX HD	
	<p>Recording for 2 monitors and a handle</p> <ul style="list-style-type: none"> - Integrated cable management - Load capacity: 6.3 - 10.5 kg - Height adjustment: 510 mm - Extension: up to 840 mm - Tilt function: 80° - Rotation: 90° - VESA mounting standard: 75 x 75 mm 100 x 100 mm - Maximum display size: 46 " <p>- When used the arm is additionally loaded with 2.7 kg.</p>	

STORAGE CONSOLE WITH CLAMPING LEVER

Part no.

32.0501/0

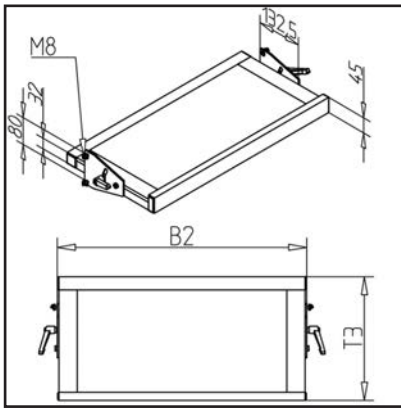

TECHN. DATA / ITEMS SUPPLIED

- Sturdy frame made of aluminum profiles anodized E6 / EV1
- Shelf for cabinet, chipboard, light grey
- Front edge 13 mm raised edges
- ESD on request
- **Please state table width B2 and depth T3**
- Load capacity: 400 N

APPLICATIONS

- Continuously inclinable from -30° to $+30^\circ$
- Rack is adjustable

ASSEMBLY

- Fastening with 2 swivel plates to the portal structure
- without clamp lever **part no. 32.0501/1**

STORAGE SHELF / MONITOR SUPPORT ROTATING CRT

Part no.

32.0512/0

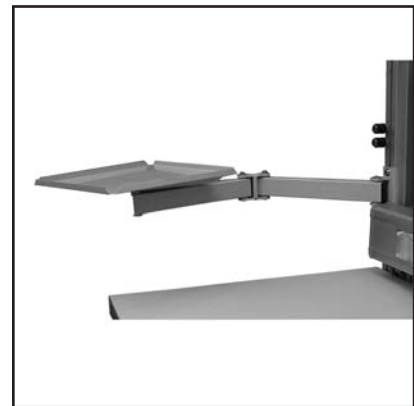
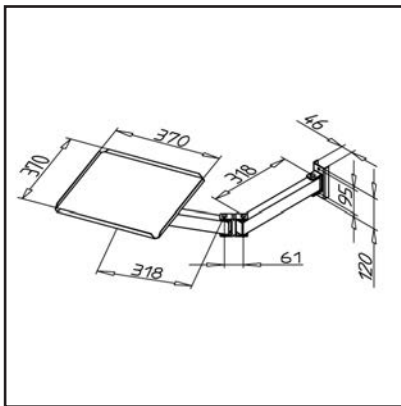

TECHN. DATA / ITEMS SUPPLIED

- Steel, powder coated, light grey
- Double joint design, length 430 mm
- Monitor and keyboard panel rotatable
- Monitor panel: 370 x 370 mm
- Load capacity 150 N
- Weight = 4.200 kg/piece

APPLICATIONS

- Provision of IT data, guidelines, Internet connection

ASSEMBLY

- Screw onto the portal structure
- Optional as ESD version **Part no. 32.0512/6**

MONITOR SUPPORT WITH KEYBOARD TRAY TFT

Part no.

32.0517/0

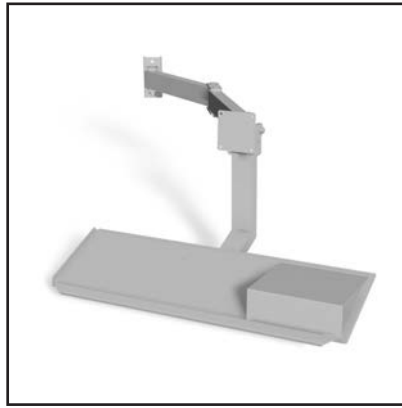
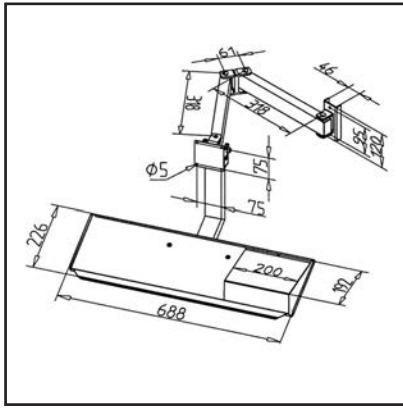

TECHN. DATA / ITEMS SUPPLIED

- Steel, powder-coated, grey
- Monitor and keyboard carrier with mouse rack
- With double-articulated swing boom
- Delivery as construction set
- ESD on request
- Load capacity 150 N
- Weight = 7.400 kg/piece

APPLICATIONS

- The mouse rack is shiftable and therefore suitable for right and left-handers

OTHER VERSIONS

- Support with keyboard shelf with VESA connection adapter 75 mm **part no. 32.0517/0**
- Support with keyboard shelf with VESA connection adapter 100 mm **part no. 32.0517/1**
- Support without keyboard shelf with VESA connection adapter 75 mm **part no. 32.0525/0**
- Support without keyboard shelf with VESA connection adapter 100 mm **part no. 32.0526/0**

KEYBOARD STORAGE

Part no.

32.0518/0

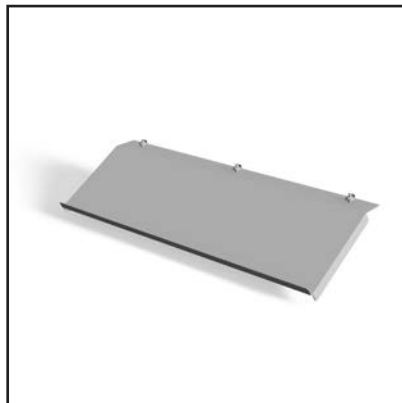
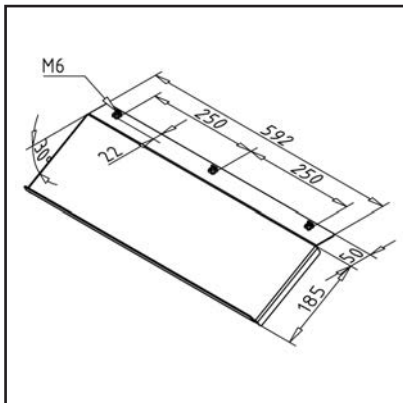

TECHN. DATA / ITEMS SUPPLIED

- Stainless steel
- Stainless steel 2mm, grounded
- Rustproof
- For standard keyboards
- With slide nuts M6Z, ESD-compatible
- Fastening material
- Load capacity 150 N
- Weight = 2.477 kg/piece

APPLICATIONS

- For setting the keyboard on the workplace

ASSEMBLY

- Fasten to profile groove with supplied hardware

MONITOR CARRIER V 100

Part no.

32.0053/0

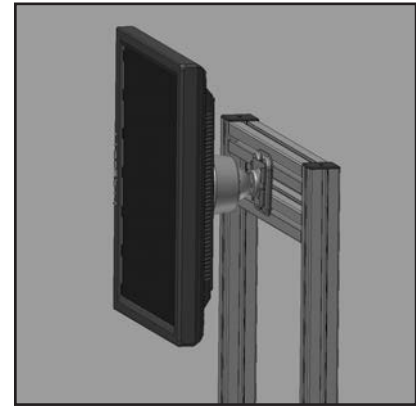
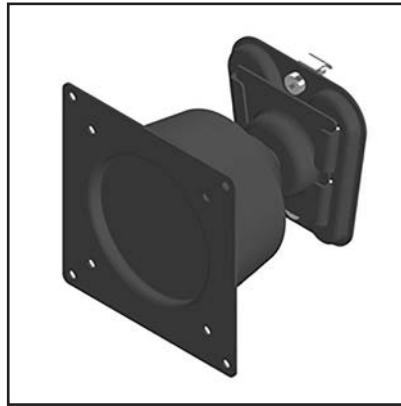
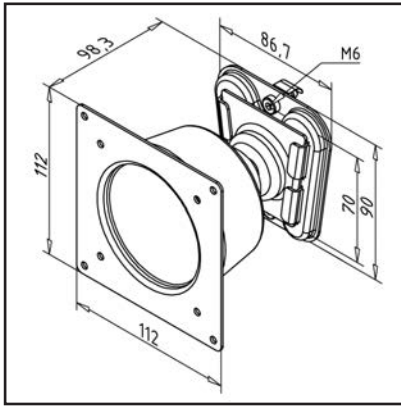
**TECHN. DATA / ITEMS SUPPLIED**

- Steel, powder coated black
- Fastening kit
- Load capacity 150 N
- Weight = 0.568 kg/piece

APPLICATIONS

- Swiveling with ball joint
- Monitor can be rotated through 180°
- For VESA standard 75 x 75 mm / 100 x 100 mm

ASSEMBLY

- Fasten to profile groove with supplied hardware.

DOCUMENT BAR

Part no.

32.0610/0

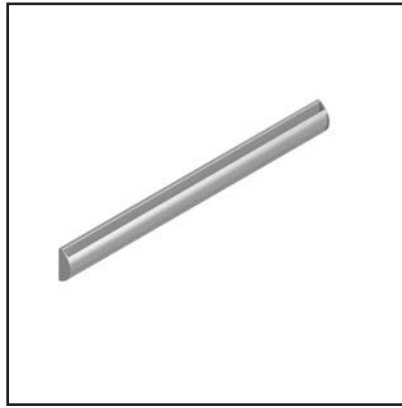
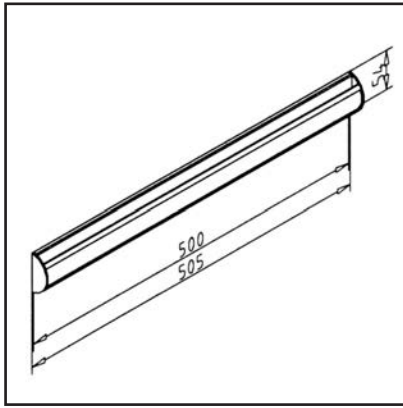

TECHN. DATA / ITEMS SUPPLIED

- Aluminium anodized
- With clamping balls made of special glass
- Length: 505 mm
- Other dimensions upon request
- Weight = 0.300 kg/piece

APPLICATIONS

- Safe attachment of large drawings, instructions, plans
- Simply slip-in papers from below
- Attach to portal construction by screwing or gluing with double-faced adhesive tape

ASSEMBLY

- Use the screws of fastening kit or fasten with adhesive tape on the back

DOCUMENT SUPPORT

Part no.

32.0605/0

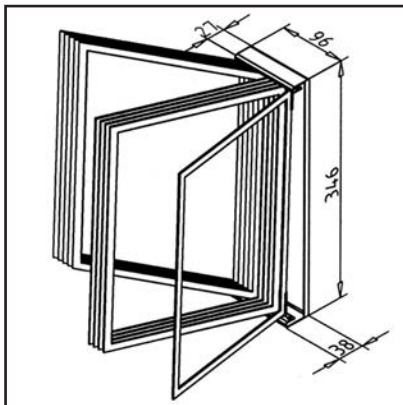

TECHN. DATA / ITEMS SUPPLIED

- Steel bracket, powder coated light grey
- 10 DIN A4 boards, transparent
- Border per 5 in blue and red
- 5 Slip-on tabs
- Weight = 1.240 kg/piece

APPLICATIONS

- Provision of job instructions, maintenance notes
- Control boards, general information
- Screw tight onto portal construction

ASSEMBLY

- Fastening with 2 hex socket cap screws M 06 x 16, 2 square nut M6 into profile groove
- ESD-design **part no. 32.0605/6**

BALANCER

Part no.

29.0111/0

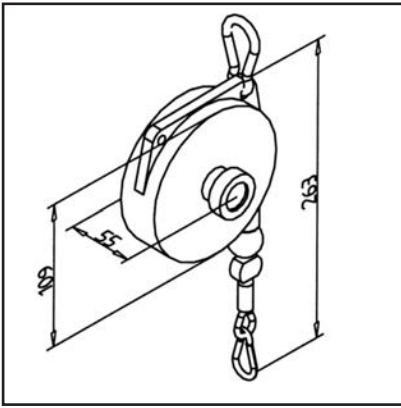

TECHN. DATA / ITEMS SUPPLIED

- For tool weights 2-3 kg
- For higher weights upon request
- Weight = 0.753 kg/piece

APPLICATIONS

- Grab-supportive tool suspensions

ASSEMBLY

- With snap hook from scope of delivery in tool glider **part no. 22.1213/0**

TOOL SLIDER H

Part no.

22.1213/0

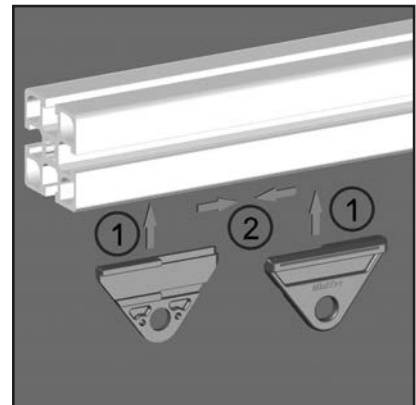
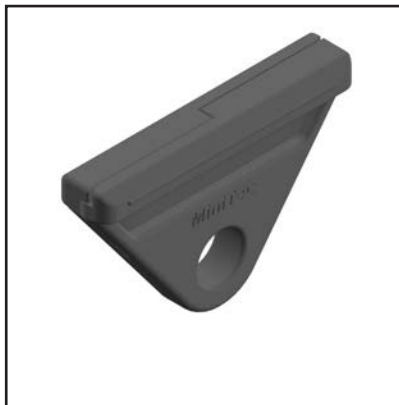
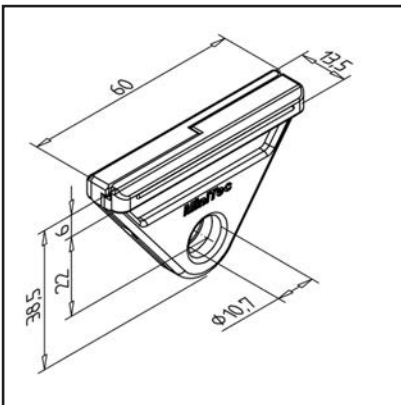

TECHN. DATA / ITEMS SUPPLIED

- ABS, Injection Mould, grey
- load capacity up to 600 N
- Weight = 0.010 kg/piece

APPLICATIONS

- Grab-supportive tool suspensions
- Suitable for all 45er profiles

ASSEMBLY

- insert both halves in profile groove and press together
- Optional: spring clip 60x6 **part no. 21.1699/0**

TOOL SLIDE

Part no.

32.0545/0

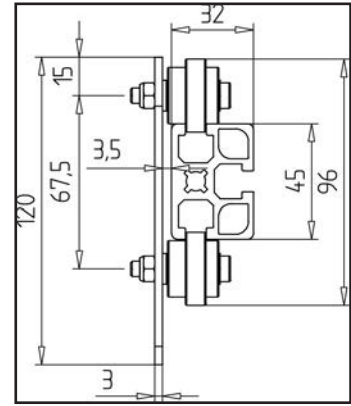
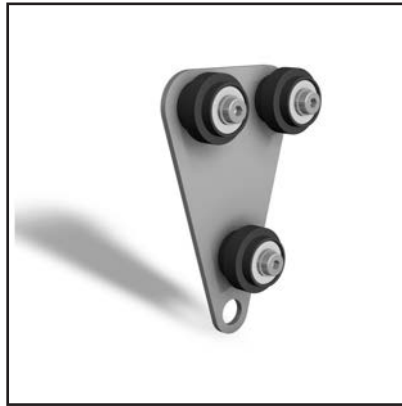
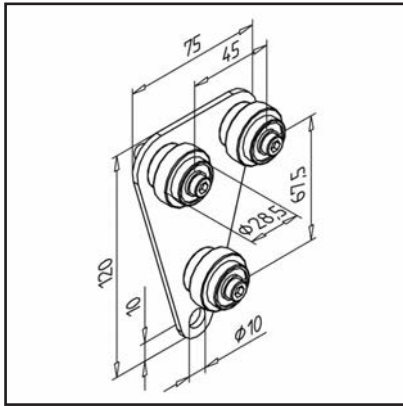
**TECHN. DATA / ITEMS SUPPLIED**

- Stainless steel
- Caster wheel ABS grey
- Load capacity F: 400 N
- Weight = 0.263 kg/piece

APPLICATIONS

- For guiding of tools on working tables

ASSEMBLY

- Slide into profile end
- Possibly before disassembly of the lower roller
- Can be used in connection with balancer, **part no. 29.0111/0**

C-SECTION RAIL 30

Part no.

32.0220/0

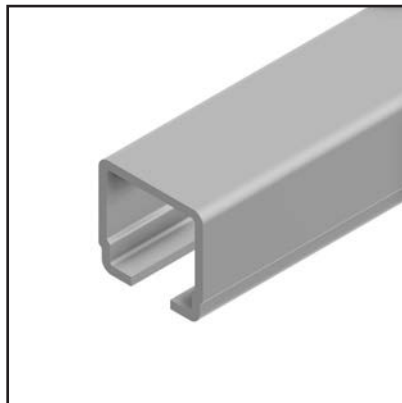
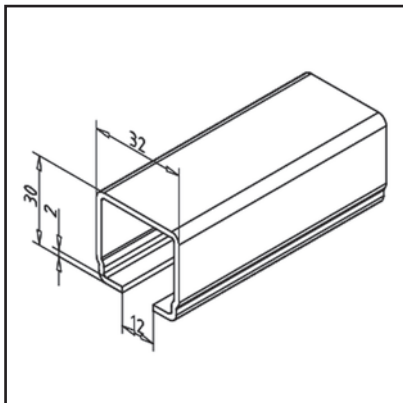
**TECHN. DATA / ITEMS SUPPLIED**

- Steel, galvanized
- $I_x = 2.42 \text{ cm}^4$
- $I_y = 1.45 \text{ cm}^4$
- ESD-compatible
- Weight = 1.560 kg/m
- Bar length = 6 m

APPLICATIONS

- Reception and guide of cable trolleys
- Reception and guide of tool trolleys to provide heavy tools

ASSEMBLY

- Attach to portal structure with rail holder **part no. 32.0222/0**

RAIL HOLDER

Part no. 32.0222/0

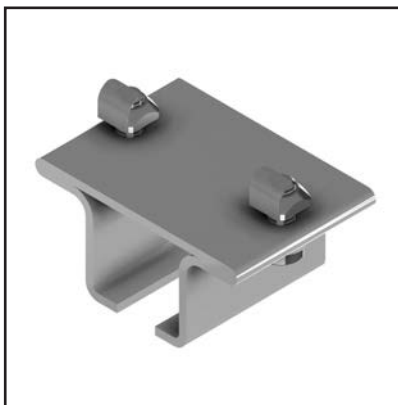
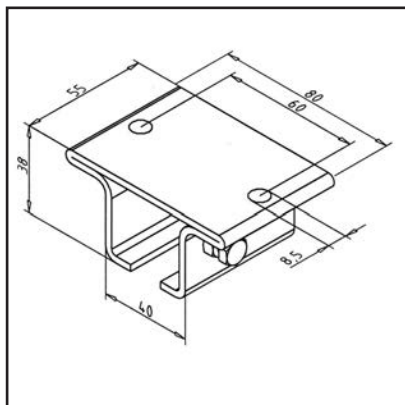

TECHN. DATA / ITEMS SUPPLIED

- Steel, galvanized
- Square nut Z, ESD capable
- Weight = 0.250 kg/piece

APPLICATIONS

- Fastening the C-section rail onto the portal structure
- Fixation for C-rail 30 **part no. 32.0220/0**

ASSEMBLY

- Fasten to the portal construction with supplied hardware

CLOSURE CAP FOR C-RAIL

Part no. 32.0223/0

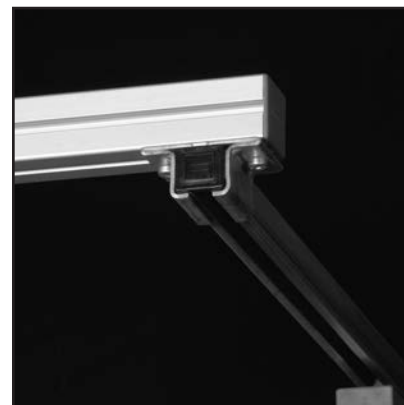
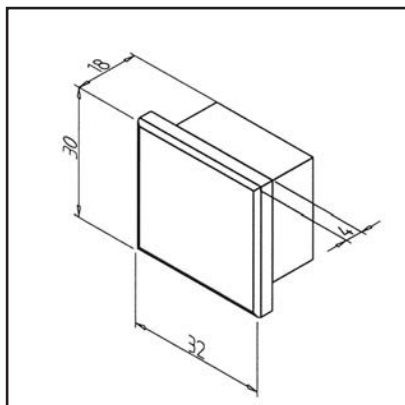

TECHN. DATA / ITEMS SUPPLIED

- Plastic, black
- Weight = 0.006 kg/piece

APPLICATIONS

- Closing of both rail ends

ASSEMBLY

- Press onto C-profile rail

END STOP C-RAIL

Part no.

32.0226/0

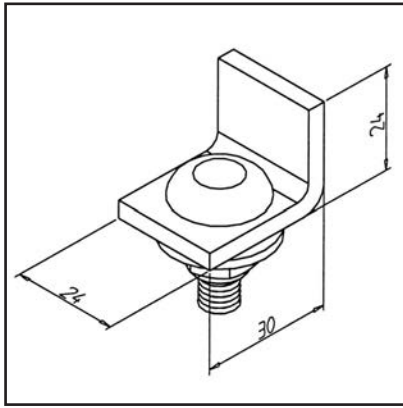
**TECHN. DATA / ITEMS SUPPLIED**

- Steel, galvanized
- Fastening material
- ESD-compatible
- Weight = 0.060 kg/piece

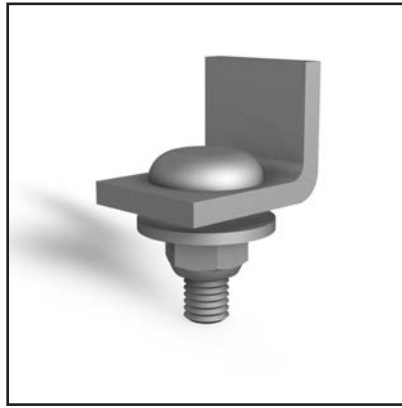
**APPLICATIONS**

- Fasten the cable trolley **part no. 32.0225/0** and tool trolley **part no. 32.0224/0** at the end of the rail

**ASSEMBLY**

- Screw into end of C-section rail

TOOL TROLLEY

Part no.

32.0224/0

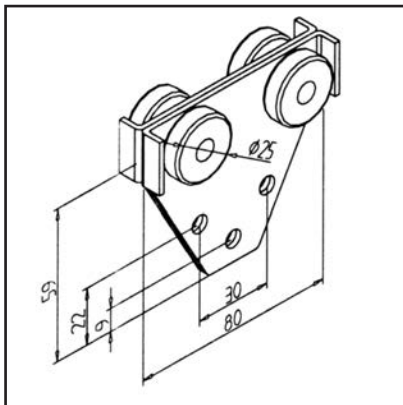
**TECHN. DATA / ITEMS SUPPLIED**

- Steel, galvanized
- 4 rollers, zinc plated, ball bearings sealed on both sides
- ESD-compatible
- Load capacity: 16 kg
- Weight = 0.210 kg/piece

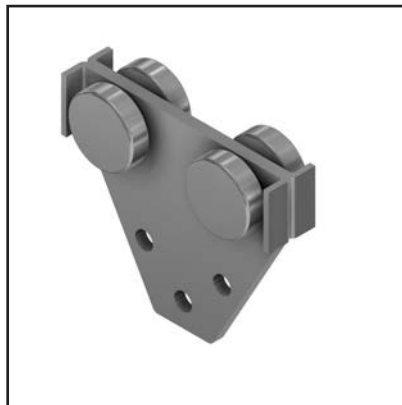
**APPLICATIONS**

- Suspension of tools in the work area

**ASSEMBLY**

- Push into C-section rail, secure ends with limit stop

CABLE TROLLEYS FOR ROUND CABLES

Part no. 32.0225/0

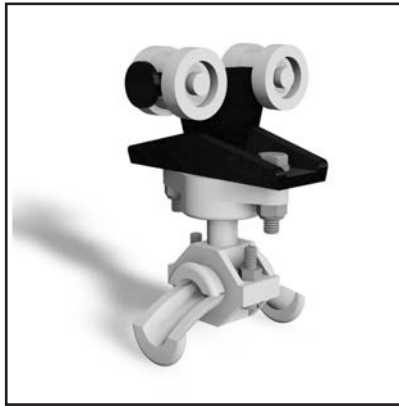
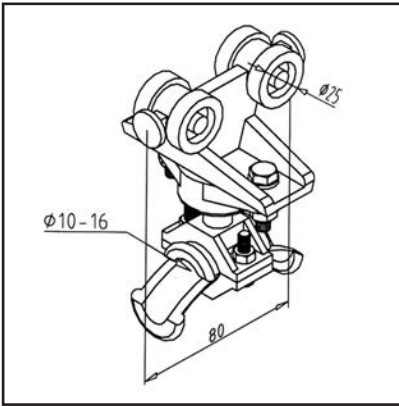

TECHN. DATA / ITEMS SUPPLIED

- Plastic, yellow
- Supporting body: plastic, yellow
- 4 plastic rollers
- Load capacity: 8 kg
- Weight = 0.135 kg/piece

APPLICATIONS

- Smooth running guidance of lines
- Suspension of hoses and pipes

ASSEMBLY

- Push into C-section rail, secure ends with limit stop

SWIVEL CANTILEVER C-RAIL 30

Part no. 32.0230/0

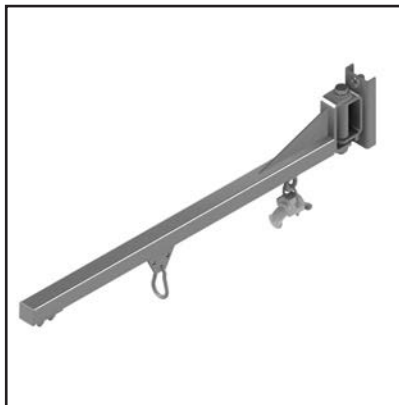
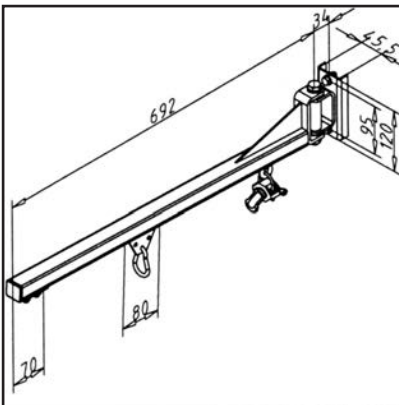

TECHN. DATA / ITEMS SUPPLIED

- Steel, powder-coated, grey
- 180° swiveling
- Fastening material
- Length: 692 mm
- Load capacity: 200 N
- Weight = 2.310 kg/piece

APPLICATIONS

- For compressed air and power tools

ASSEMBLY

- Slight slope to the rear, so that unused tool slides automatically from work area
- Fasten to the portal construction with supplied hardware
- Optional: as ESD design **part no. 32.0230/6**

SWIVEL ARM ECO

Part no.

32.0201/0

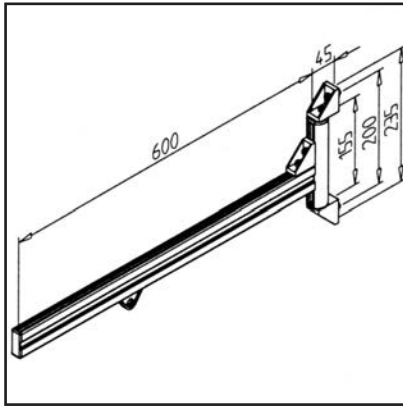
**TECHN. DATA / ITEMS SUPPLIED**

- Aluminium
- 200° swiveling
- Fastening material
- plain bearing
- Length: 600 mm
- Load capacity: max.= 100 N
- Weight = 1.100 kg/piece

APPLICATIONS

- For compressed air and power tools

ASSEMBLY

- Fixing to portal with angle
- Fasten to the portal construction with supplied hardware

CONTAINER HOLDER 32-400

Part no.

32.0306/0

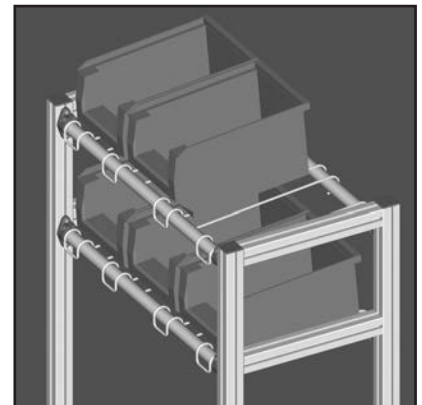
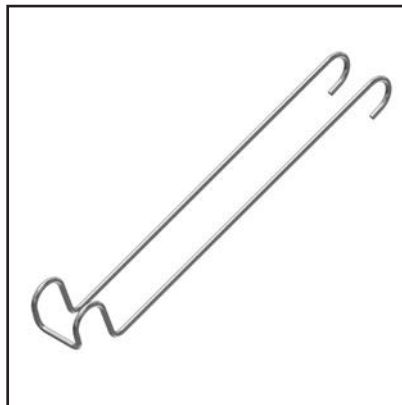
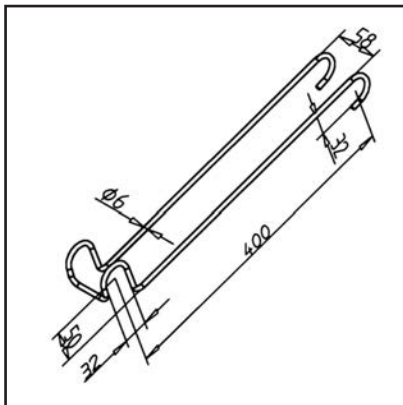
**TECHN. DATA / ITEMS SUPPLIED**

- Steel, galvanized
- Without fastening kit
- Weight = 0.268 kg/piece

APPLICATIONS

- as depositing rack for semi-open front containers and storage containers

ASSEMBLY

- simply hooked into handle profile 32 from both sides
- Recommended: If required, secure laterally against sliding of snap bolt 25 **part no. 21.1758/0**

MOUNTING BLOCK

Part no.

32.0539/0

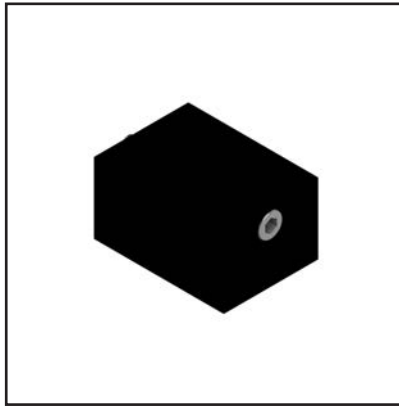
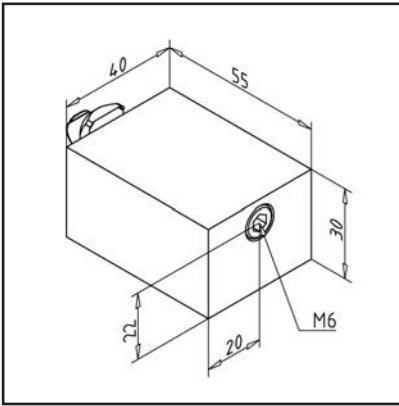

TECHN. DATA / ITEMS SUPPLIED

- Plastic
- Color: black
- Fastening kit
- Square nut Z, ESD capable
- Weight = 0.078 kg/piece

APPLICATION

- For self drilling of individual hole patterns
- To provide tools etc.

ASSEMBLY

- Fasten into profile groove with fastening kit

ATTACHMENT CLIP 16

Part no.

32.0538/0

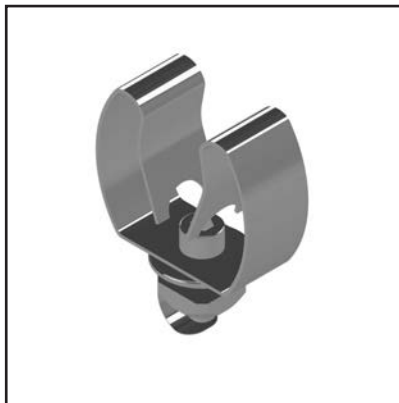
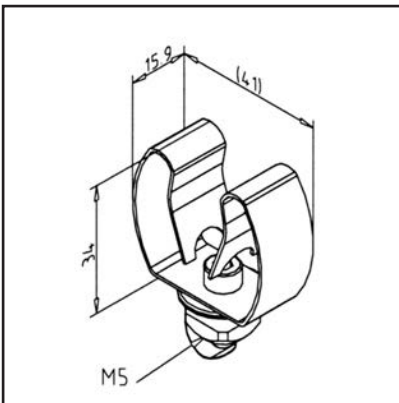

TECHN. DATA / ITEMS SUPPLIED

- Steel
- Stainless steel 1.4319
- Attachment clip with fastening kit
- Square nut Z, ESD capable
- Weight = 0.028 kg/piece

APPLICATIONS

- Holder for various tools with \varnothing 16 - 25 mm

ASSEMBLY

- Fasten into the profile groove with supplied hardware and tighten the fastening screw

ATTACHMENT CLIP 8

Part no.

32.0537/0

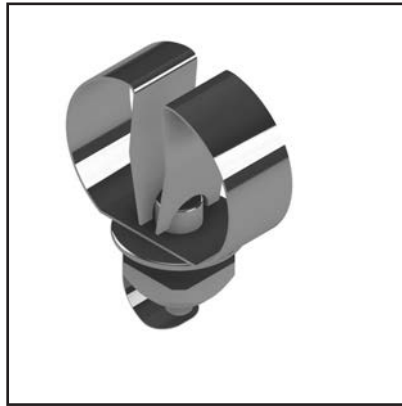
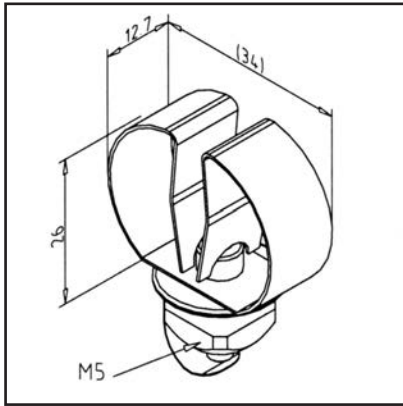
**TECHN. DATA / ITEMS SUPPLIED**

- Steel
- Stainless steel 1.4319
- Attachment clip with fastening kit
- Square nut Z, ESD capable
- Weight = 0.017 kg/piece

APPLICATIONS

- Holder for various tools with \varnothing 8 - 12 mm

ASSEMBLY

- Fasten into the profile groove with supplied hardware and tighten the fastening screw

ROUND TOOL HOLDER 38 - 120

Part no.

32.0536/0

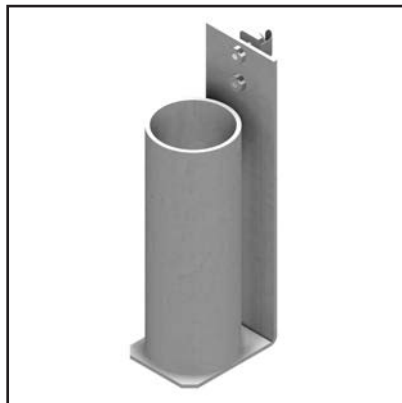
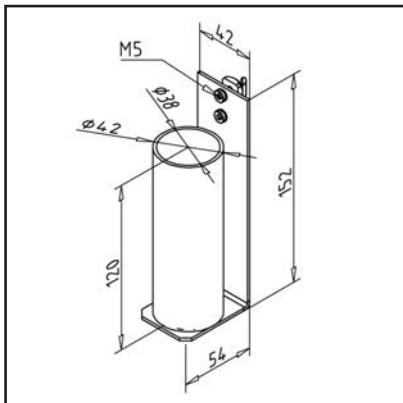
**TECHN. DATA / ITEMS SUPPLIED**

- Stainless steel
- Material V2A, polished
- Fastening kit
- Square nut Z, ESD capable
- Weight = 0.402 kg/piece

APPLICATIONS

- Tool holder for storage of tools, pins, etc.
- Adjustable angle

ASSEMBLY

- Attach with fastening kit from items supplied to profile strut

ROUND TOOL HOLDER 38-70

Part no.

32.0535/0

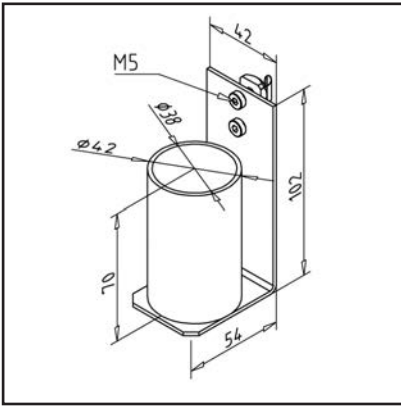

TECHN. DATA / ITEMS SUPPLIED

- Stainless steel
- Material V2A, polished
- Fastening kit
- Square nut Z, ESD capable
- Weight = 0.263 kg/piece

APPLICATIONS

- Tool holder for storage of tools (files, marking tools, sharpening stones, etc.)
- Adjustable angle

ASSEMBLY

- Attach with fastening kit from items supplied to profile strut

STEEL BRACKET 250

Part no.

32.0533/0

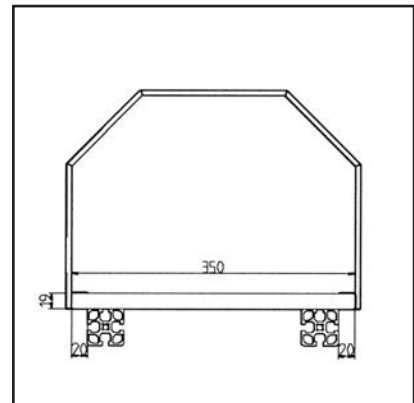
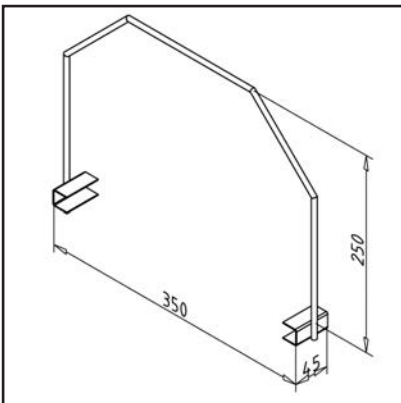

TECHN. DATA / ITEMS SUPPLIED

- Steel, powder-coated, grey
- With welded-on clamps for setting on a 19 mm chipboard, for example
- Clamped using pretensioning and can be secured additionally with wood screws
- Weight = 0.214 kg/piece

APPLICATIONS

- As separating web for cartons
- Magazine for flat parts

ASSEMBLY

- Pull apart gently, stick on at the correct position and secure with suitable screw

STEEL BRACKET 400

Part no.

32.0534/0

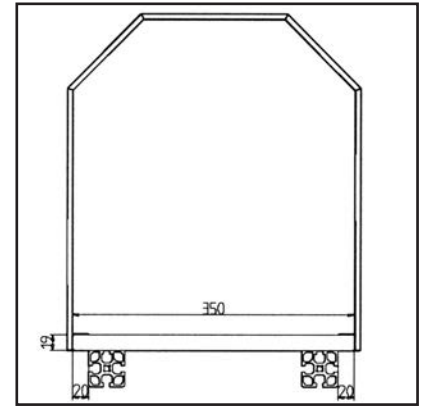
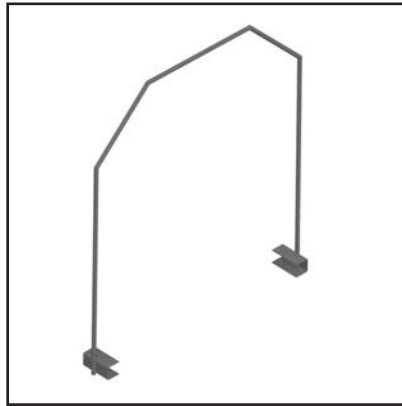
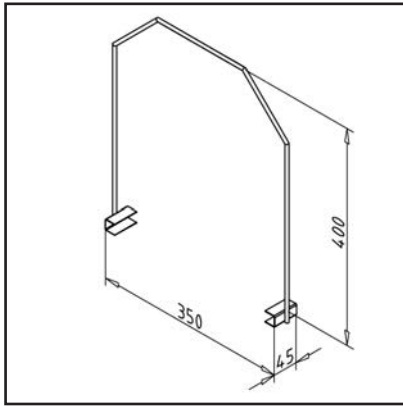
**TECHN. DATA / ITEMS SUPPLIED**

- Steel, powder-coated, grey
- With welded-on clamps for setting on a 19 mm chipboard, for example
- Clamped using pretensioning and can be secured additionally with wood screws
- Weight = 0.278 kg/piece

APPLICATIONS

- As separating web for cartons
- Magazine for flat parts

ASSEMBLY

- Pull apart gently, stick on at the correct position and secure with suitable screw

DRAWING HOLDER

Part no.

32.0608/0

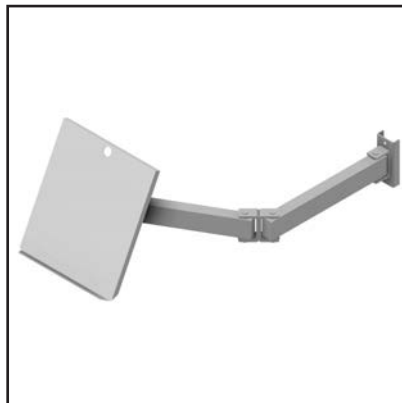
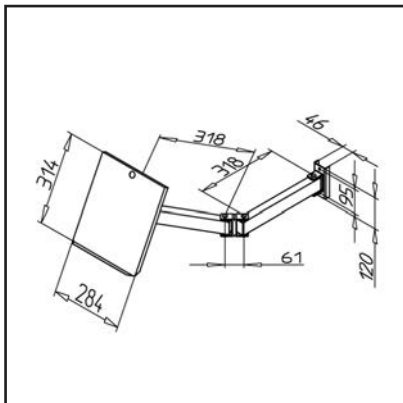
**TECHN. DATA / ITEMS SUPPLIED**

- Steel light grey, powder coated
- With double-articulated swing boom
- For DIN A4 format
- Load capacity 150 N
- Delivery as construction set
- ESD on request
- Weight = 4.000 kg/piece

APPLICATIONS

- For documents, control charts and drawings

ASSEMBLY

- Fasten to the portal structure

DOCUMENT CLIP

Part no.

32.0609/0

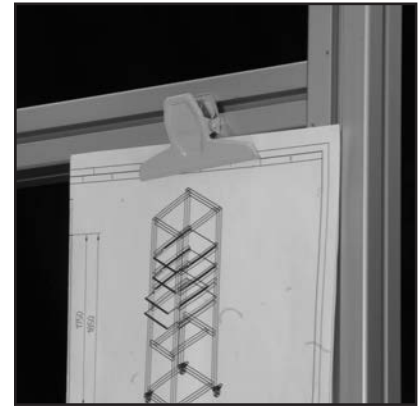
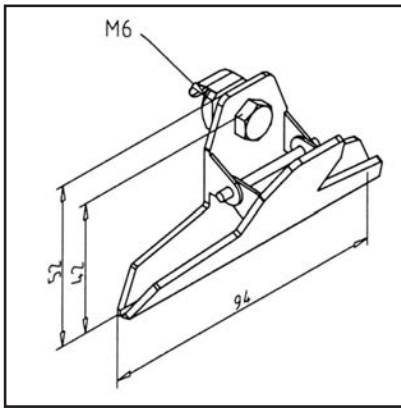

TECHN. DATA / ITEMS SUPPLIED

- Steel light grey, powder coated
- With fastening bore \varnothing 6mm
- Width x height 94 x 52 mm
- Weight = 0.048 kg/piece

APPLICATIONS

- To fastening work instructions, work plans or the like to workbenches or other profile constructions

ASSEMBLY

- Insert square nut M6 into profile groove and fasten with the screw

QUICK LABEL 27 X 75

Part no.

32.0601/0

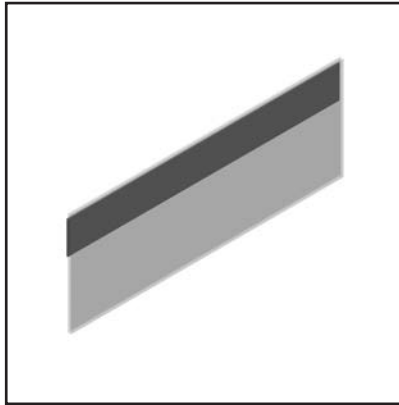
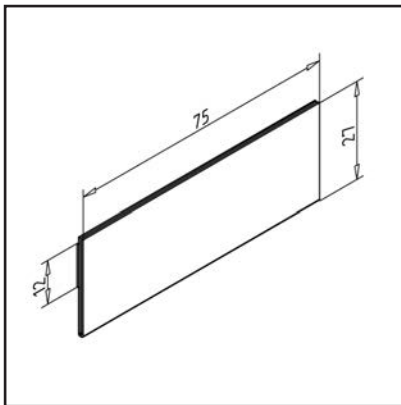

TECHN. DATA / ITEMS SUPPLIED

- Front, transparent
- Back, self-adhesive
- Open at the sides and on top
- Weight = 0.003 kg/piece

APPLICATIONS

- Storage compartment identification
- Error-free scanning of barcodes
- For profile width 32

ASSEMBLY

- Attach with self-adhesive back
- Push in carton insert
- Cardboard insert not included in delivery scope, bows 20 pieces **part no. 32.0601/1** please order separately

QUICK LABEL 38 X 100

Part no.

32.0602/0

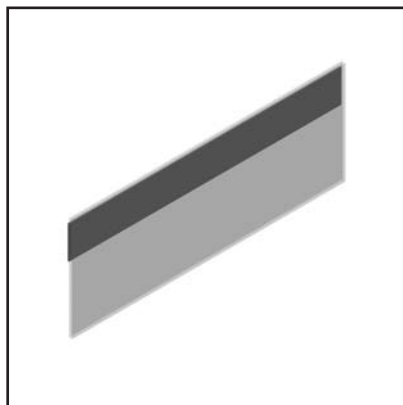
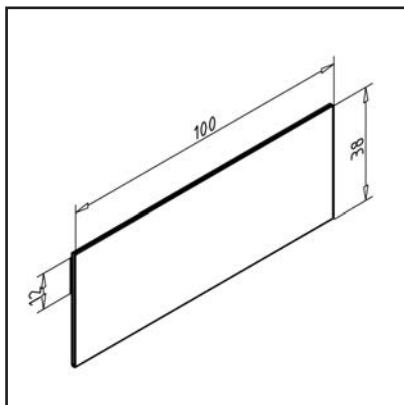
**TECHN. DATA / ITEMS SUPPLIED**

- Front, transparent
- Back, self-adhesive
- Open at the sides and on top
- Weight = 0.007 kg/piece

APPLICATIONS

- Storage compartment identification
- Error-free scanning of barcodes
- For profile width 45

ASSEMBLY

- Attach with self-adhesive back
- Push in carton insert
- Cardboard insert not included in delivery scope, bows 14 pieces **part no. 32.0602/1** please order separately

SEMI-OPEN COMPARTMENT BASE ELEMENT

Part no.

32.0615/0

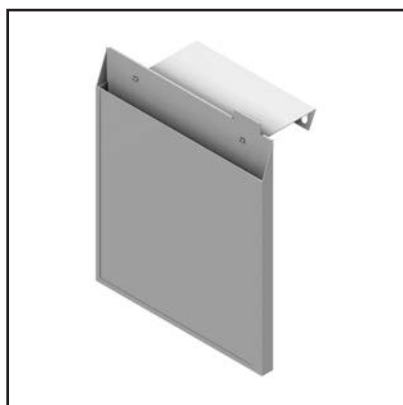
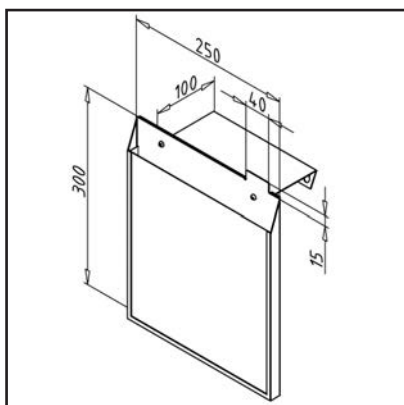
**TECHN. DATA / ITEMS SUPPLIED**

- Steel light grey, powder coated
- With fastening bores $\varnothing 9$, spacing 160 mm
- Optical edge 45 mm for optimum overview
- Filling capacity = 15 mm, sufficient for approx. 120 sheets of paper
- With grey closing plate
- clear semi-open compartment (front plate)
- Weight = 0.634 kg/piece

APPLICATIONS

- For size DIN A4 documents

ASSEMBLY

- Fasten to the portal structure
- Any time expandable with **part no. 32.0616/0**
- Extract the front panel during extension and attach it to the last extension element again

SEMI-OPEN COMPARTMENT EXTENSION ELEMENT

Part no. 32.0616/0

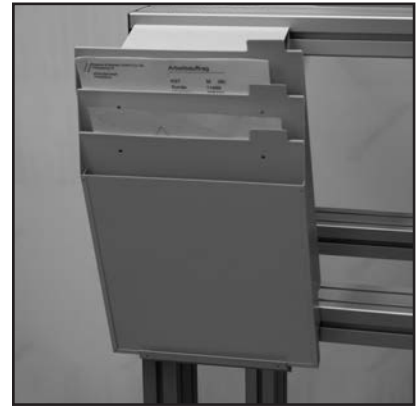
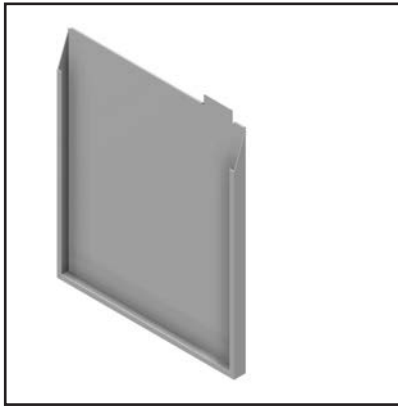
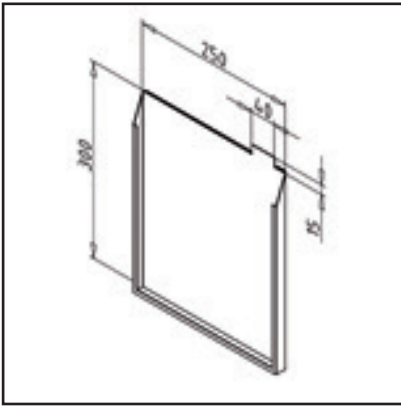

TECHN. DATA / ITEMS SUPPLIED

- Steel, powder coated, light grey
- Filling capacity = 15 mm, sufficient for approx. 120 sheets of paper
- Weight = 0.392 kg/piece

APPLICATIONS

- For size DIN A4 documents

ASSEMBLY

- Place base element on compartment **part no. 32.0615/0**

SEMI-OPEN COMPARTMENT, SINGLE

Part no. 32.0617/0

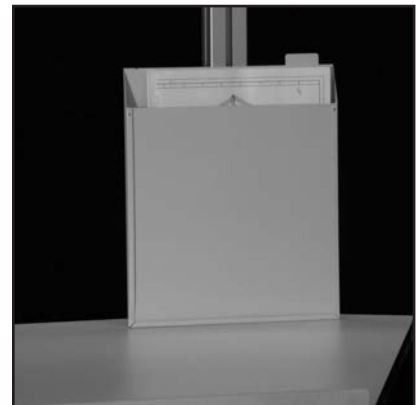
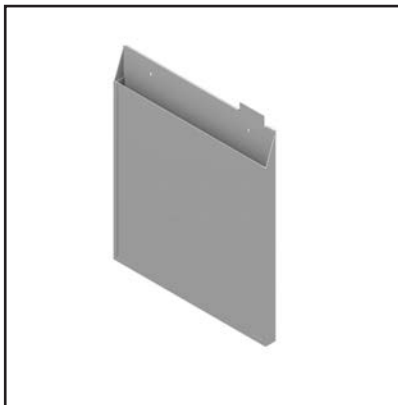
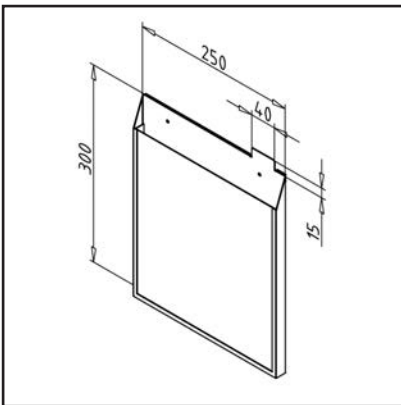

TECHN. DATA / ITEMS SUPPLIED

- Steel, powder coated, light grey
- With fastening bores \varnothing 4 mm, spacing approx. 16 mm
- With grey closing plate
- Weight = 0.500 kg/piece

APPLICATIONS

- For size DIN A4 documents
- Optional: compartment single element DIN A4 portrait format with transparent locking plate **part no. 32.0619/0**

ASSEMBLY

- Attach to the portal structure or use as an extension element for the base element

ADDITIONAL ANGLE FOR VIEWING COMPARTMENT

Part no.

32.0618/0

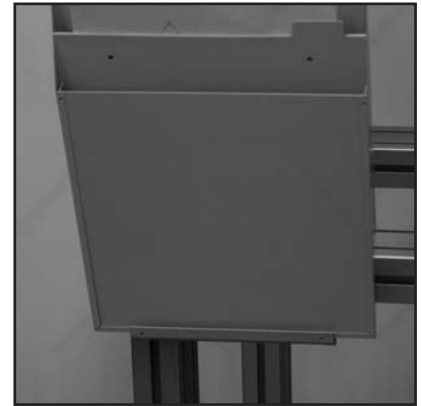
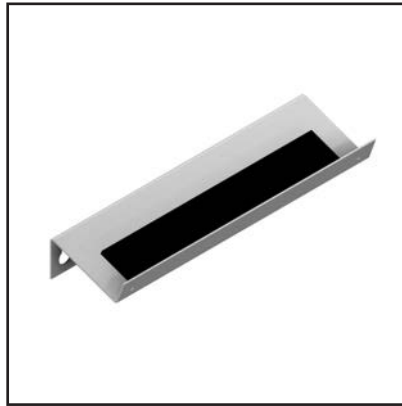
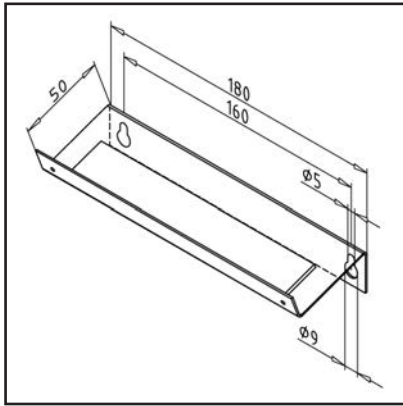
**TECHN. DATA / ITEMS SUPPLIED**

- Steel light grey, powder coated
- With magnet strips
- Weight = 0.123 kg/piece

APPLICATIONS

- For additional stabilisation on the bottom edge of the semi-open compartments

ASSEMBLY

- Fasten to the portal structure

CUP HOLDER

Part no.

32.0547/0

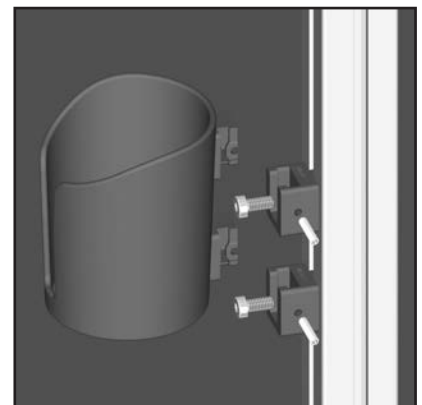
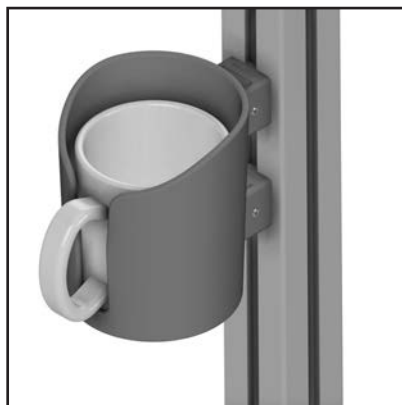
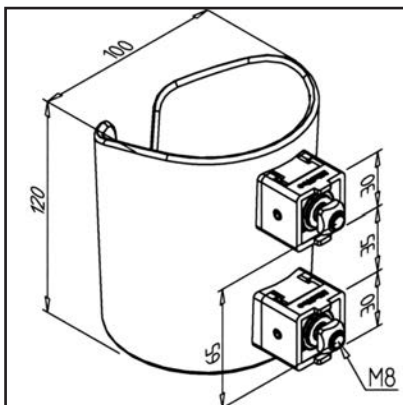
**TECHN. DATA / ITEMS SUPPLIED**

- PA, grey
- Fastening kit
- Weight = 0.388 kg/piece

APPLICATIONS

- Cup or bottle holder for workplace systems
- With cut-out for cup handle

ASSEMBLY

- Fasten rectangular connectors to post profile with supplied hardware at a distance of 35 mm
- Insert cup holder in t-slot
- For adjustment use set screw M5

BOTTLES/DRINK CARTON HOLDER

Part no.

32.0507/0

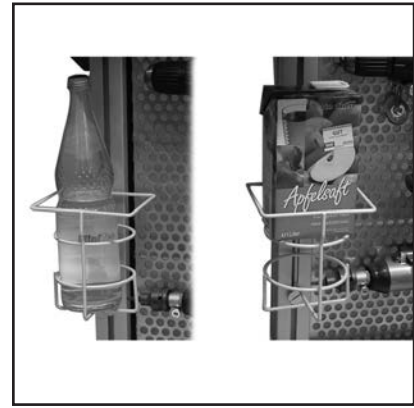
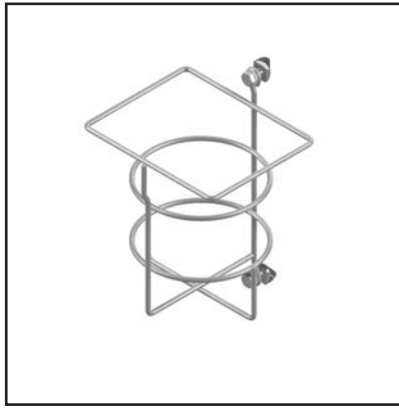
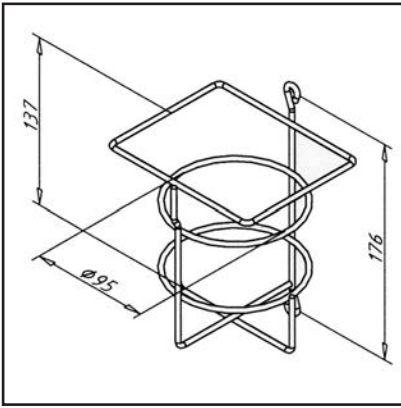

TECHN. DATA / ITEMS SUPPLIED

- Steel wire, coated light grey
- Inside Ø 95 mm
- 2 screws M6 x 16
- 2 square nuts M6 with spring plate
- Weight = 0.195 kg/piece

APPLICATIONS

- Commercially available beverage bottles and beverage bags

ASSEMBLY

- Screw down with fastening material

WASTE SEPARATION

Part no.

29.0022/0

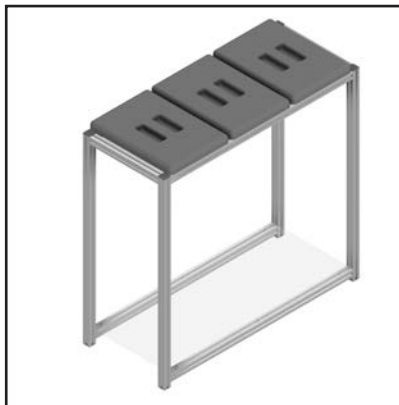
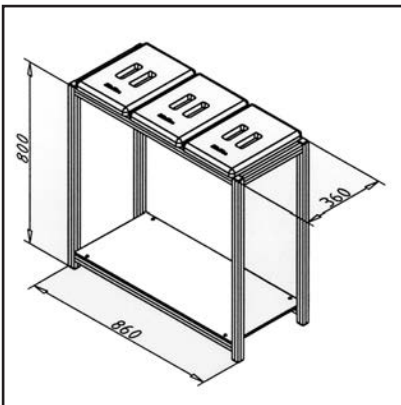

TECHN. DATA / ITEMS SUPPLIED

- Sturdy frame of profile 30 x 30, anodized E6 / EV1
- Delivery as construction set
- With shelf
- 3 covers ABS, grey
- Weight = 7.023 kg/piece

APPLICATIONS

- For separate collection of 3 kinds of recyclable materials
- Just put plastic bags over the screw heads
- Also suitable for outdoor deployment

ASSEMBLY

- According to enclosed installation instructions

RECYCLABLE MATERIAL COLLECTOR FOR ATTACHMENT

Part no.

32.0024/0

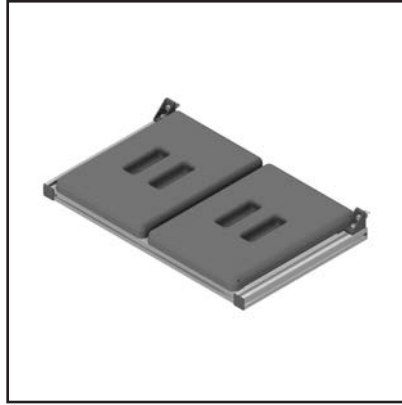
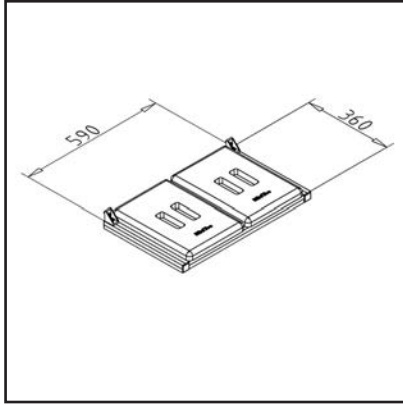

TECHN. DATA / ITEMS SUPPLIED

- Frame made of profile 30 x 30, anodized E6 / EV1
- 2 covers ABS, grey
- 2 mounting angles 25
- Weight = 1.915 kg/piece

APPLICATIONS

- For separate collection of 2 kinds of recyclable materials
- Just put plastic bags over the screw heads

ASSEMBLY

- Attach to profile frame with fastening materials included

TOOL CASE S AS SET

Part no.

26.3001/0

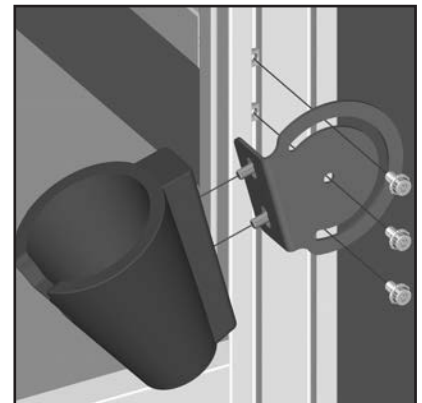
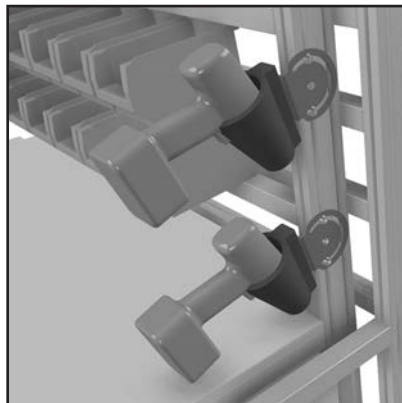
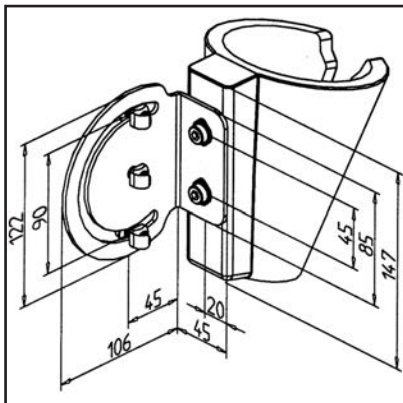

TECHN. DATA / ITEMS SUPPLIED

- Tool quiver, rubber, black
- Swivel bracket, steel, grey, powder-coated
- With fastening material steel, zinc plated
- Weight = 0.830 kg/piece

APPLICATIONS

- For secure storage of drills, battery-operated screwdrivers and other tools
- Adjustable angle

ASSEMBLY

- Fasten to the profile brace with supplied hardware

BASE SET TOOL CASE

Part no.

26.3004/0

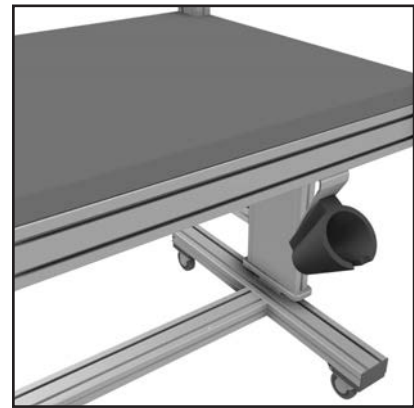
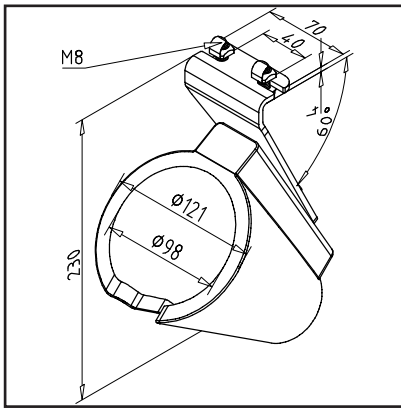

TECHN. DATA / ITEMS SUPPLIED

- Tool quiver, rubber, black
- Holder, stainless steel
- With fastening material steel, zinc plated
- Weight = 0.885 kg/piece

APPLICATIONS

- For secure storage of drills, battery-operated screwdrivers and other tools
- For ergonomic provision of tools below the work surface

ASSEMBLY

- Fasten to the profile brace with supplied hardware

TOOL CASE S

Part no.

26.3001/1

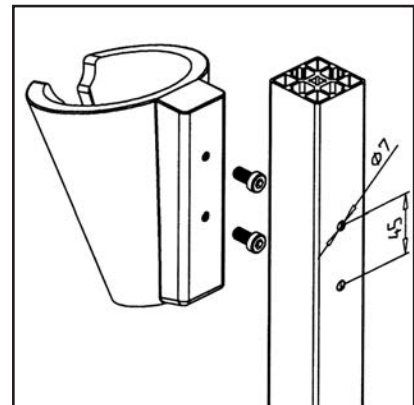
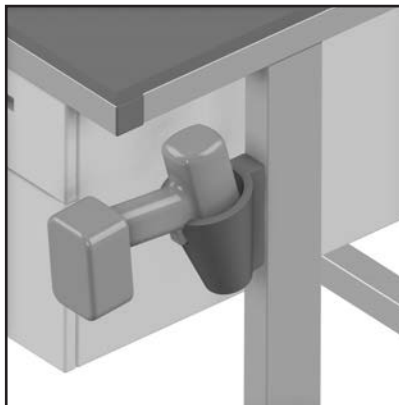
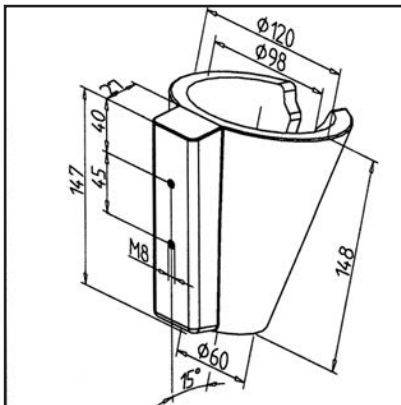

TECHN. DATA / ITEMS SUPPLIED

- Rubber, black
- Weight = 0.492 kg/piece

APPLICATIONS

- For secure storage of drills, battery-operated screwdrivers and other tools

ASSEMBLY

- Drill 2 bores $\varnothing 7$ mm, distance of 45 into profile
- Fasten with screws M8 x 16

ADAPTER FOR TOOL CASE

Part no.

26.3002/0

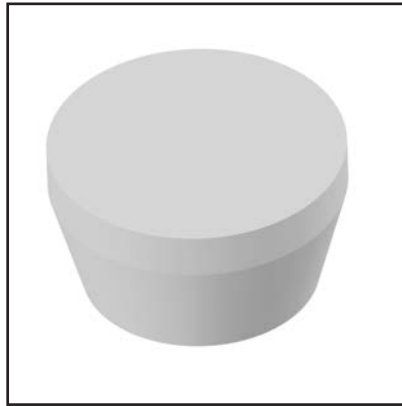
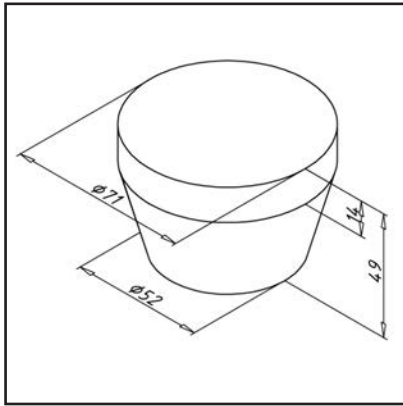
**TECHN. DATA / ITEMS SUPPLIED**

- POM, white
- Standard: without machining
Optional: with machining eg. aptly drilled or milled for special tools
- Weight = 0.225 kg/piece

APPLICATIONS

- Adapter for rod screwdrivers, special screwdrivers, pneumatic screwdrivers and smaller hand tools

ASSEMBLY

- Press into tool quiver

SWIVEL HOLDER

Part no.

26.3001/2

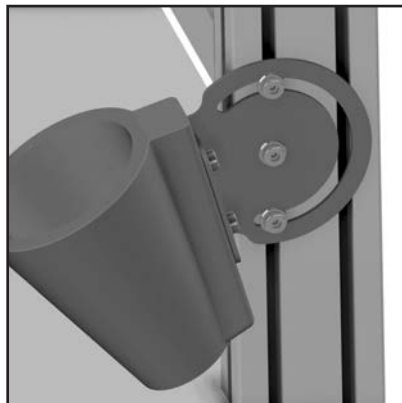
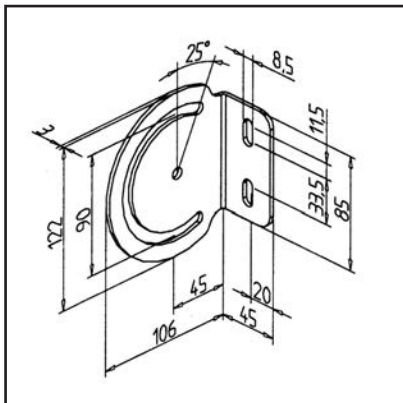
**TECHN. DATA / ITEMS SUPPLIED**

- Steel, powder-coated, grey
- Powder coated RAL 7012
- Weight = 0.283 kg/piece

APPLICATIONS

- For swiveling attachment of toolboxes, profiles or shelves

ASSEMBLY

- With screws M8 x 16 or clamping lever and M8 sliding nut

SCREWDRIVER HOLDER

Part no.

32.0502/0

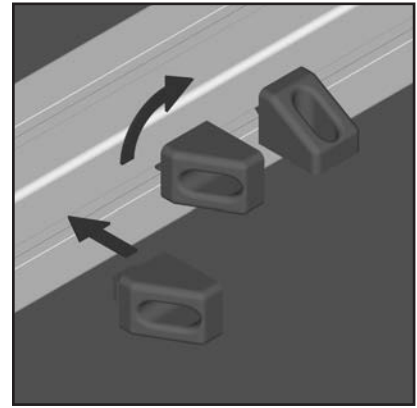
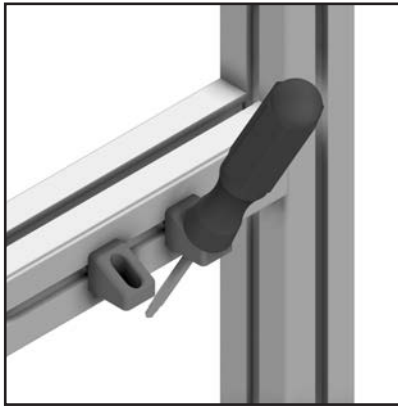
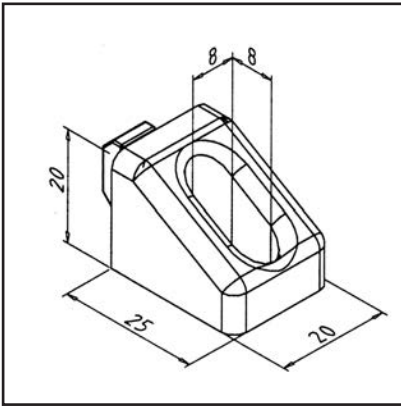

TECHN. DATA / ITEMS SUPPLIED

- PA, Injection Mould, grey
- Weight = 0.006 kg/piece

APPLICATIONS

- Ergonomic storage of screwdrivers at the workbench

ASSEMBLY

- Push into the groove and then turn 90°

BRUSH STRIP 30

Part no.

22.1150/0

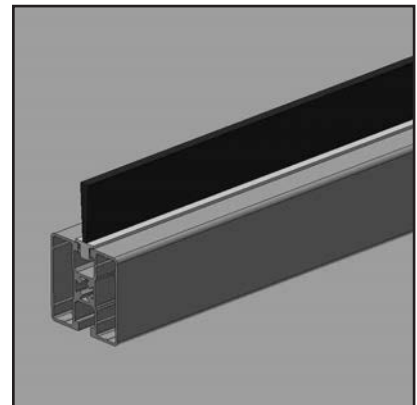
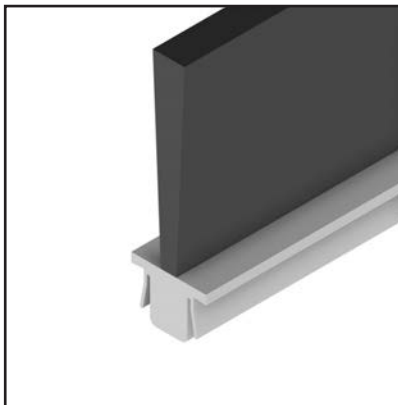
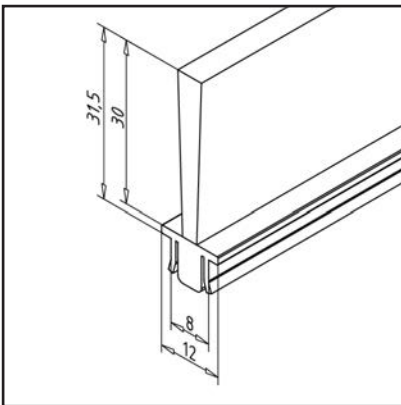

TECHN. DATA / ITEMS SUPPLIED

- PVC strip with brush
- Manufacturing length: 1000 mm
- Weight = 0.128 kg/m

APPLICATIONS

- Sealing of doors, lids
- Static strap cleaning in case of minor soiling
- Guiding and carrying in conveyor technology

ASSEMBLY

- Insert or clip into profile groove

VERTICAL DOUBLE OUTLET

Part no.

32.0773/0

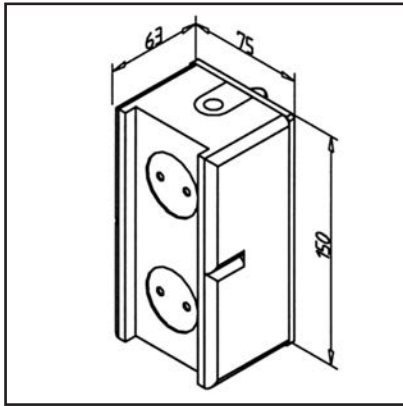
**TECHN. DATA / ITEMS SUPPLIED**

- Schuko 10 / 16 A 250 V
- IP 44 shatter-proof
- Housing 75 x 75 x 58 mm
- Fastening material
- With adapter plate and screws
- Weight = 0.389 kg/piece

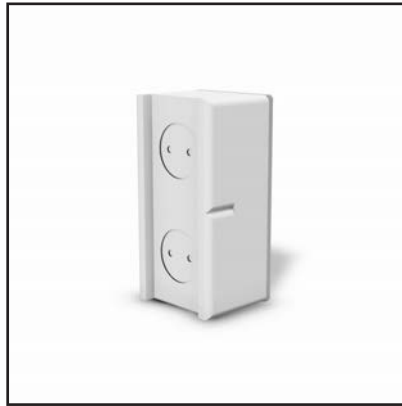
**APPLICATIONS**

- For power supply at the workplace

**ASSEMBLY**

- Attach the adapter plate to the profile
- Fasten double outlet to the adapter plate

HORIZONTAL DOUBLE OUTLET

Part no.

32.0774/0

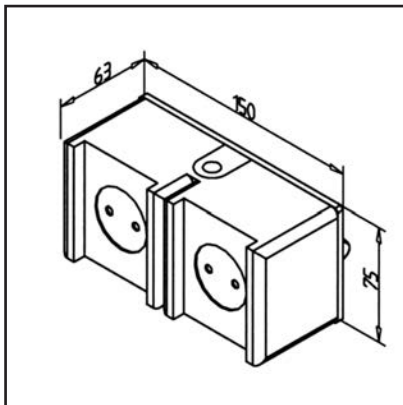
**TECHN. DATA / ITEMS SUPPLIED**

- Schuko 10 / 16 A 250 V
- IP 44 shatter-proof
- Housing 75 x 75 x 58 mm
- Fastening material
- With adapter plate and screws
- Weight = 0.389 kg/piece

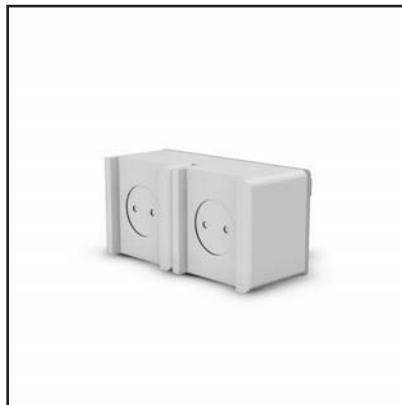
**APPLICATIONS**

- For power supply at the workplace

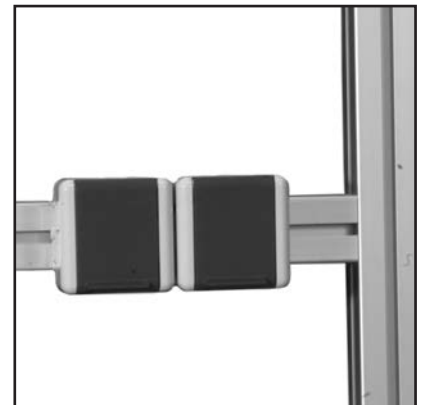
**ASSEMBLY**

- Attach the adapter plate to the profile
- Fasten double outlet to the adapter plate

POWER OUTLET

Part no.

32.0771/0

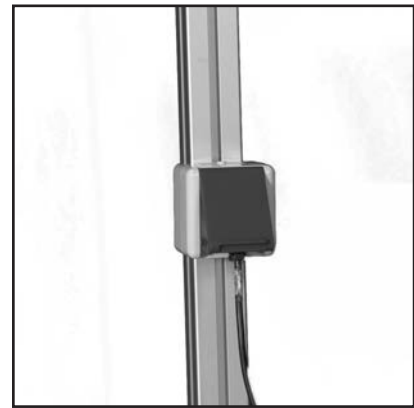
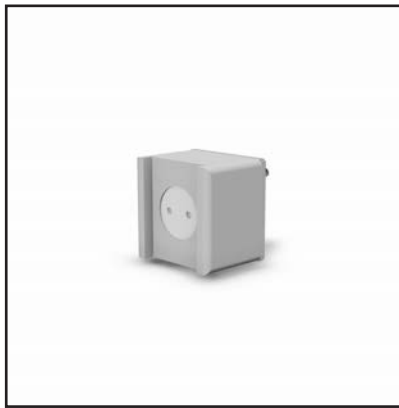
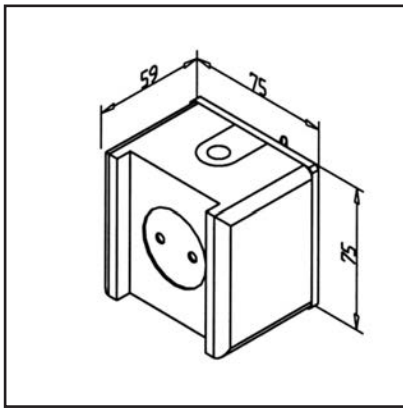
**TECHN. DATA / ITEMS SUPPLIED**

- Schuko 10 / 16 A 250 V
- IP 44 shatter-proof
- Housing 75 x 75 x 58 mm
- With adapter plate and screws
- Weight = 0.211 kg/piece

APPLICATIONS

- For power supply at the workplace

ASSEMBLY

- Attach the adapter plate to the profile
- Fasten double outlet to the adapter plate

TOGGLE SWITCH/POWER OUTLET

Part no.

32.0772/0

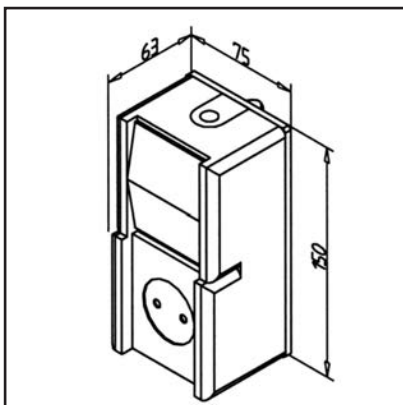
**TECHN. DATA / ITEMS SUPPLIED**

- OFF switch, 10A x 250V
- Schuko 10 / 16 A 250 V, IP 44 shatter-proofed
- Housing 75 x 75 x 58 mm
- Fastening material
- With adapter plate
- Weight = 0.389 kg/piece

APPLICATIONS

- For switching lights on and off

ASSEMBLY

- Attach the adapter plate to the profile
- Fasten the switch on the adapter plate

TOGGLE SWITCH

Part no.

32.0770/0

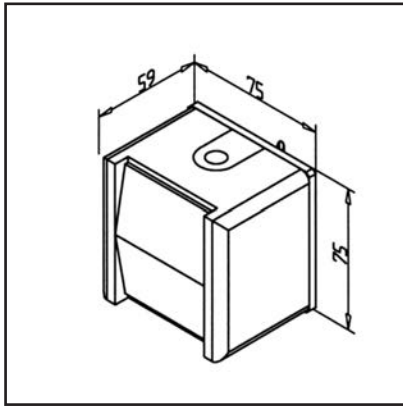
**TECHN. DATA / ITEMS SUPPLIED**

- OFF switch
- 10A x 250V
- Housing 75 x 75 x 58 mm
- Fastening material
- With adapter plate

- Weight = 0.211 kg/piece

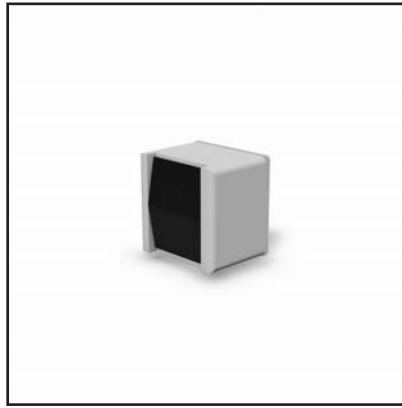
**APPLICATIONS**

- For switching lights on and off

**ASSEMBLY**

- Attach the adapter plate to the profile
- Fasten the switch on the adapter plate

SOCKET STRIPS 7-FOLD

Part no.

32.0703/0

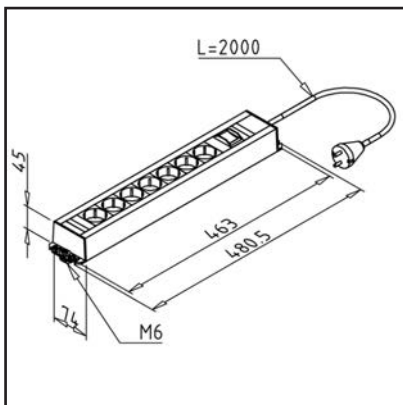
**TECHN. DATA / ITEMS SUPPLIED**

- 7-fold with additional switch
- Rocker switch, illuminated
- Cable length 2 m
- Max. 3500W / 16A / 230V
- Weight = 0.858 kg/piece

**APPLICATIONS**

- Oblique socket arrangement

**ASSEMBLY**

- Fasten to profile groove with supplied hardware

SOCKET STRIP ALU 3-FOLD

Part no.

32.0704/0

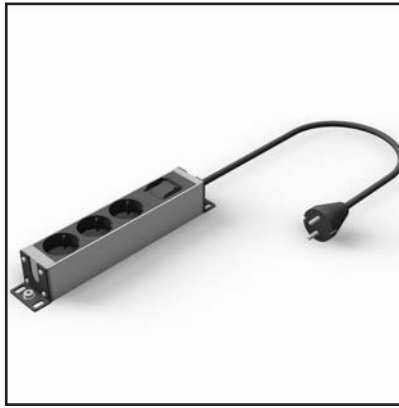
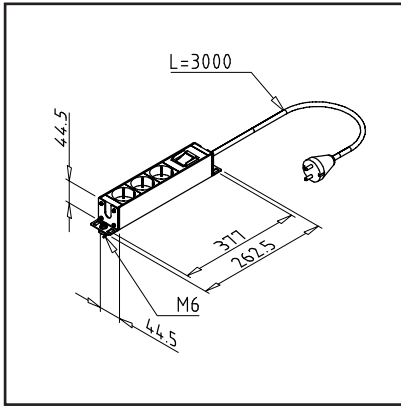

TECHN. DATA / ITEMS SUPPLIED

- Rocker switch, illuminated
- Max. 3500W / 16A / 230V
- Cable length 3 m
- Housing Aluminum natural anodized
- Weight = 0.718 kg/piece

APPLICATIONS

- Oblique socket arrangement

ASSEMBLY

- Fasten to profile groove with supplied hardware

SOCKET STRIP ALU 6-FOLD

Part no.

32.0705/0

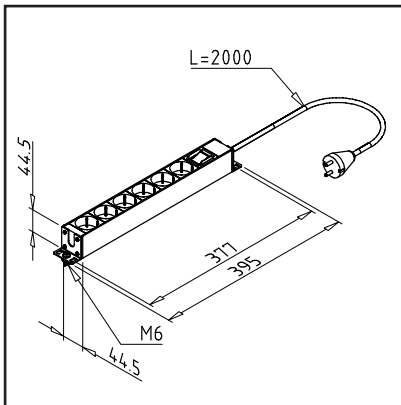

TECHN. DATA / ITEMS SUPPLIED

- Housing Aluminum natural anodized
- Rocker switch, illuminated
- Max. 3500W / 16A / 230V
- Cable length 2 m
- Weight = 0.848 kg/piece

APPLICATIONS

- Oblique socket arrangement

ASSEMBLY

- Fasten with fastening material to profile groove

SOCKET STRIP ALU 8-FOLD

Part no.

32.0706/0

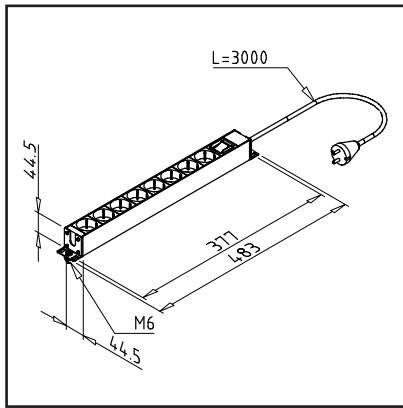
**TECHN. DATA / ITEMS SUPPLIED**

- Rocker switch, illuminated
- Max. 3500W / 16A / 230V
- Cable length 3 m
- Housing Aluminum natural anodized
- Weight = 0.848 kg/piece

APPLICATIONS

- Oblique socket arrangement

ASSEMBLY

- Fasten to profile groove with supplied hardware

FOOT REST ECO

Part no. 32.0155/0

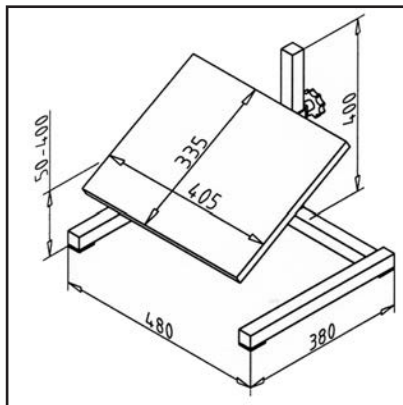

TECHN. DATA / ITEMS SUPPLIED

- Stable tubular steel frame made of 30 mm square tube
- Fully assembled
- Foot rest: Grooved anti skid rubber
- W x L x H= 400 x 330 x 410 mm
- ESD on request
- Height-adjustable and inclinable
- Inclination adjustable by foot
- Free-standing
- Weight = 5.700 kg/piece

APPLICATIONS

- Facilitates proper sitting at the table

FOOT REST STANDARD

Part no. 32.0160/0

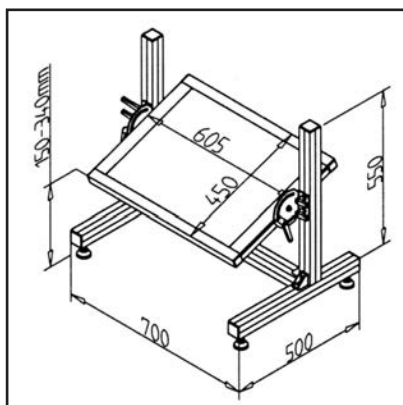

TECHN. DATA / ITEMS SUPPLIED

- Base construction profile 45x45 under tables, workstations
- Fully assembled
- Footrest: chipboard, coated, basalt grey, oil resistant
- ESD on request
- Height and inclination manually adjustable
- Free-standing
- Weight = 9.475 kg/piece

APPLICATIONS

- Facilitates proper sitting at the table

FOOT REST COMFORT

Part no.

32.0165/0

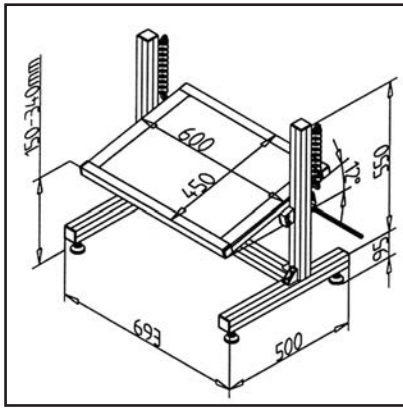
**TECHN. DATA / ITEMS SUPPLIED**

- Base construction profile 45x45 under tables, workstations
- Fully assembled
- Footrest: chipboard, coated, basalt grey, oil resistant

- ESD on request
- Spring-tensioned height adjustment, height adjustable from seating position
- Free-standing
- Weight = 10.200 kg/piece

APPLICATIONS

- Facilitates proper sitting at the table

PNEUMATICS



Compressed air is often used in the workplace systems for the operation of pneumatic cylinders in mounting devices or for the drive of compressed air tools. In order to minimize contamination at the workplace and to keep the health burden on employees as low as possible, one should always try to work with clean and dry compressed air.



FILTER REGULATOR AND MANUAL START-UP VALVE

Part no.

32.0580/0

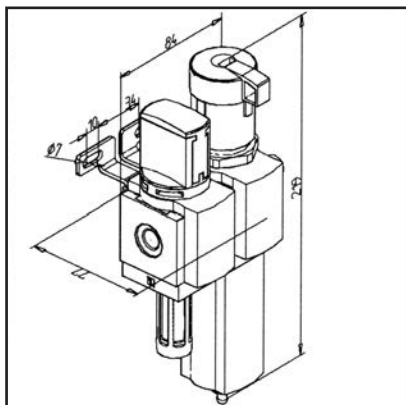
**TECHN. DATA / ITEMS SUPPLIED**

- The compressed air service module consists of: Manual start-up valve with ventilation via filter, filter regulator, rotary knob with integrated lock and manometer
- Filter mesh 40 µm
- Condensate drain
- Pressure control range: 1-12 bar
- Connection inlet 1/4" thread
- Connection outlet connector system hose D=10 mm
- Standard nominal flow 800 - 1.400 l/min
- Weight = 0.575 kg/piece

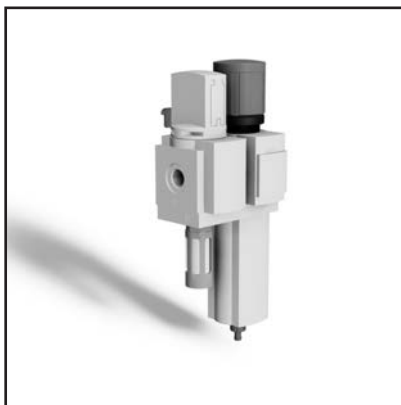
**APPLICATIONS**

- Compressed air provision on the work table

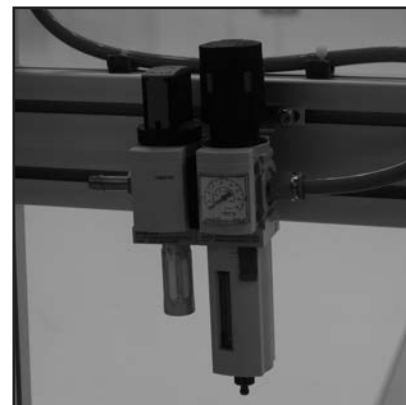
**ASSEMBLY**

- 2x Cyl. Screw M6 x 12 **part no. 21.1143/0**
- 2x square nuts M6 x 13 with retaining plate **part no. 21.1330/2**

LUBRICATOR

Part no.

32.0581/0

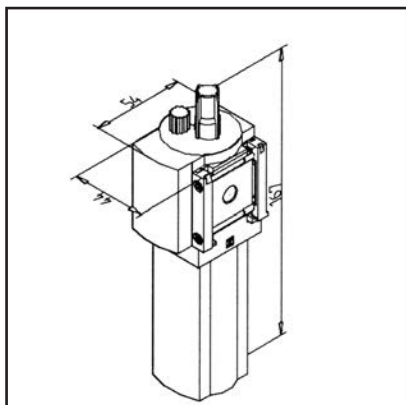
**TECHN. DATA / ITEMS SUPPLIED**

- Proportional lubricator with precise oil dosing
- Easy and fast to refill
- Weight = 0.225 kg/piece

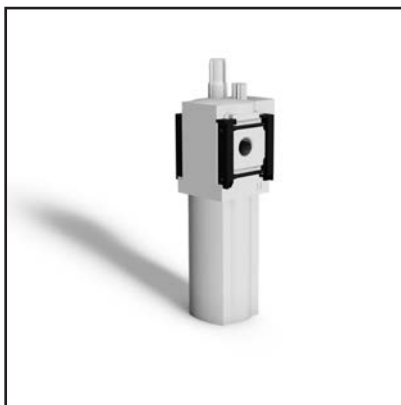
**APPLICATIONS**

- Micro-mist oil for compressed air

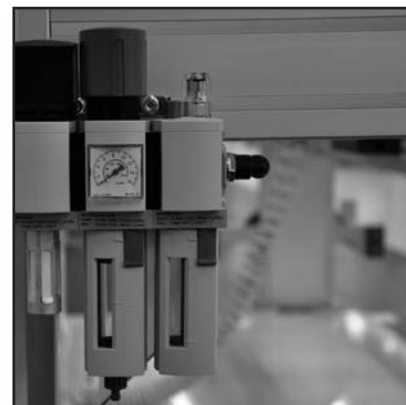
**ASSEMBLY**

- Attach to the filter regulator with the enclosed coupling package

PNEUMATIC 3-WAY DISTRIBUTOR

Part no.

32.0901/0

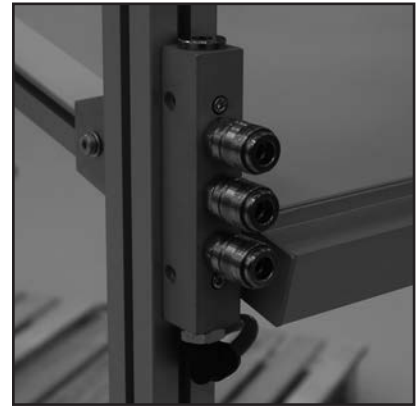
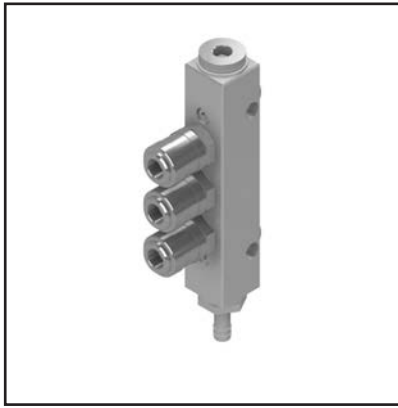
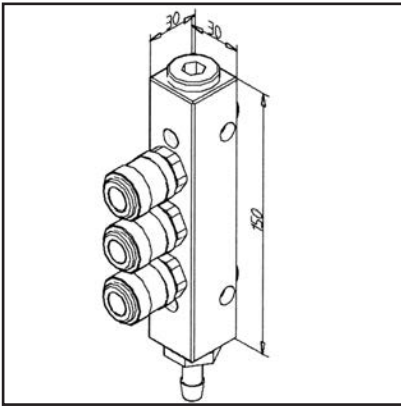

TECHN. DATA / ITEMS SUPPLIED

- Aluminium housing
- 1x connection hose nozzle for hose NW 9
- 3x quick-connect NW 7
- Operating range 0-10 bar
- Temperature range -10 to +70°C
- Connection with push-on fitting on request
- Weight = 0.665 kg/piece

APPLICATIONS

- Compressed air distribution at the workplace
- Fast connection and disconnection of pressurized compressed air lines
- Plug nipple rotatable in the coupling

ASSEMBLY

- Fasten to profile with supplied hardware
- Push on hose and secure with suitable hose clamp

AUTOM. HOSE REEL

Part no.

32.0583/0

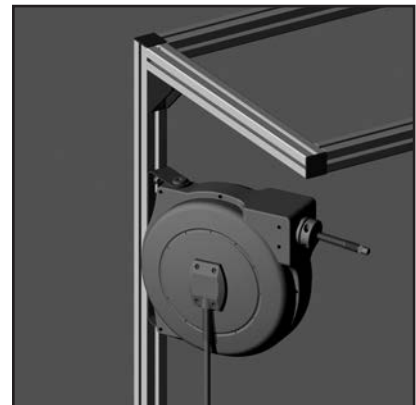
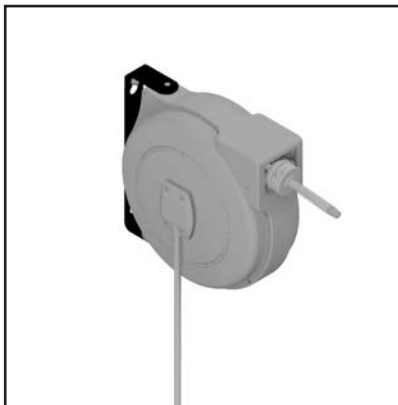
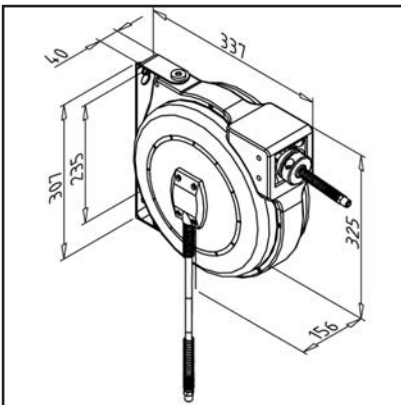

TECHN. DATA / ITEMS SUPPLIED

- Plastic, blue/ black
- 1x hose recoiler with PU-hose and stopper incl. 1m connecting hose
- Dimensions (LxWxH) 325 x 275 x 185 mm
- Hose length 8 m
- Connection In/outlet 1/4"
- max. pressure 10 bar
- Weight = 3.433 kg/piece

APPLICATIONS

- Automatic hose reel made of plastic
- Multiple arrester per turn
- disengageable locking

ASSEMBLY

- Fasten to profile with supplied hardware

KANBAN-SYSTEM

Low stock levels and avoidance of waste are constant challenges in mass production. With consumption-based disposition procedures according to the kanban principle, these goals can be achieved with simple means. The required parts in production are requested by the consuming point in the production process with a simple kanban card from the upstream stage. The card is usually located on the material and triggers a production order when the minimum stock is reached. In order to ensure the consumption-controlled production and thus the minimization of stocks, no order may be started without this kanban card. The products are provided directly at the point of consumption in so-called kanban shelves. These shelves are equipped with inclined roller conveyors, which transport by gravity the containers or products to the collection point. The shelves are loaded from the back. The size of the shelves depends on the stock at the workplace determined according to kanban rules. So that the containers are transported safely and

gently on the shelf, the inclination of the roller tracks is easily adjustable. To avoid damage caused by impacts, brake plates or brake rollers are available which are easy to assemble. Especially with higher weights, the use of these brake plates may be required. All components required to build customized kanban shelves are available in our product range.

Especially suitable for the management of small parts according to the kanban principle is our Kantainer.

(Part no. 32.0870/0)



CONVEYOR ROLLER D 25

Part no.

21.1701/0

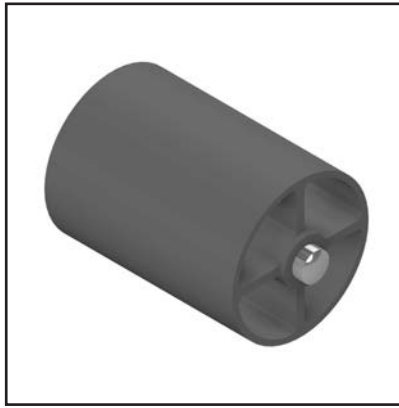
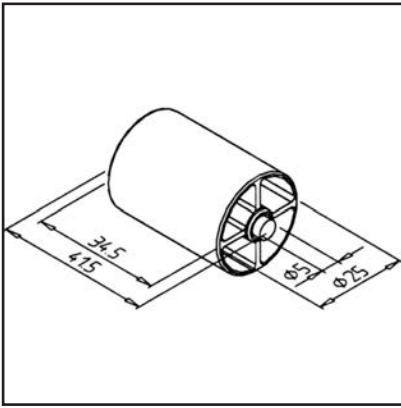

TECHN. DATA / ITEMS SUPPLIED

- ABS, blue
- Axe $\varnothing 5$, stainless steel
- Bearing capacity per roller 20 N
- For higher loads use Pulley D 25 compact **part no. 21.1703/0**
- Weight = 0.008 kg/piece

APPLICATIONS

- Production of small roller conveyors in connection with profile 45 x 45 R, **part no. 20.1046/0**

ASSEMBLY

- Press rollers in desired number and pitch into roller carrier
- Roller carrier 45 x 45 R with cover **part no. 22.1151/0**
- Roller carrier 45 x 45 R with SF cover **part no. 22.1152/0**

RETURN STOP

Part no.

32.0586/0

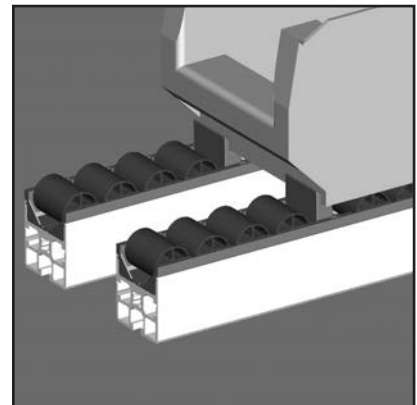
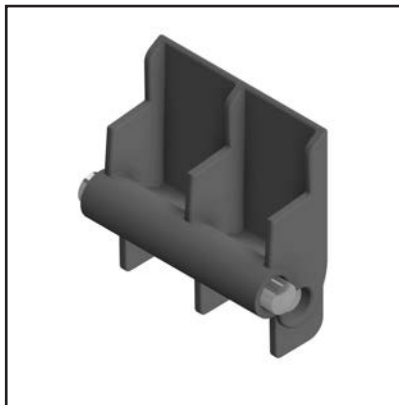
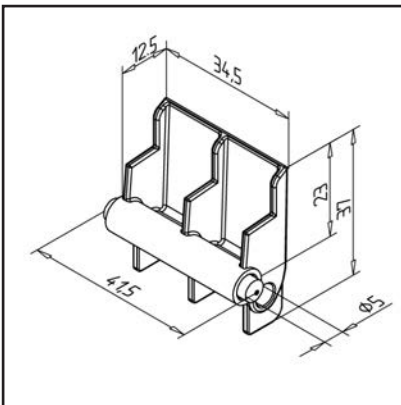

TECHN. DATA / ITEMS SUPPLIED

- ABS, grey
- Weight = 0.015 kg/piece

APPLICATIONS

- used for decline-roller conveyors to prevent transported material from running back
- in combination with pulley carrier 45x45R

ASSEMBLY

- Clip into the roller carrier instead of a roller

ROLLER CARRIER BACKING PADS

Part no. 21.0940/0

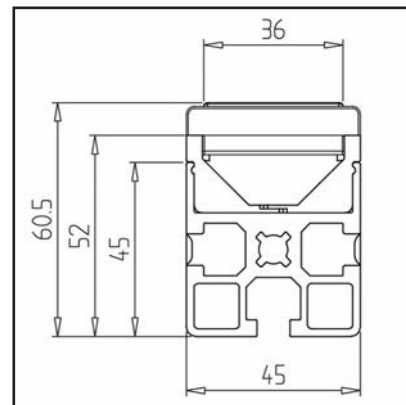
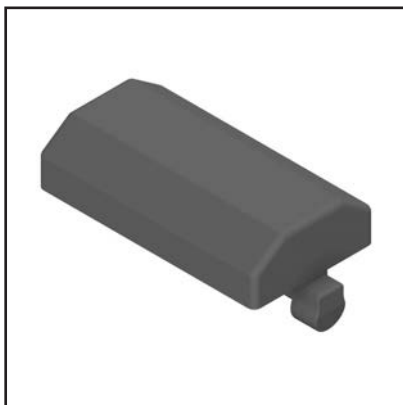
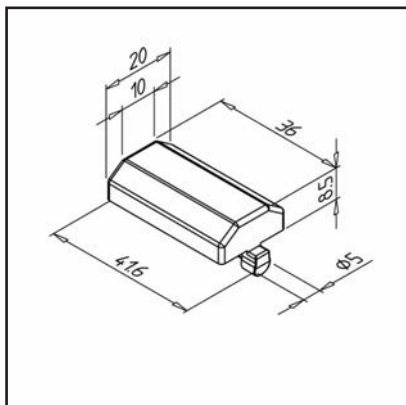
**TECHN. DATA / ITEMS SUPPLIED**

- POM, grey RAL 7012
- Suitable for roller carrier
- Weight = 0.004 kg/piece

APPLICATIONS

- For use in roller carriers instead of D25 roller for braking transport material
- To prevent a roll away on the installation site

ASSEMBLY

- Clip into the roller carrier instead of a roller

ROLLER CARRIER 45 X 45 R WITH COVER

Part no. 22.1151/0

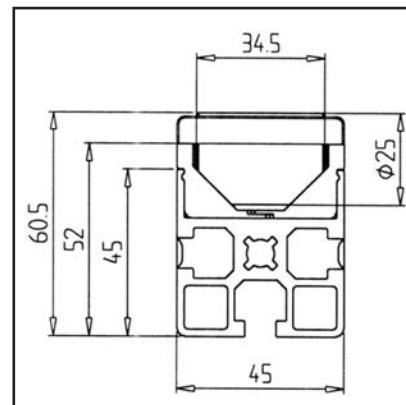
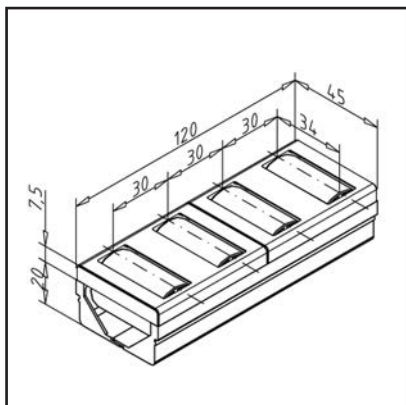
**TECHN. DATA / ITEMS SUPPLIED**

- POM, grey
- 2 x pulley carriers base part POM-RAL 7012, **part no. 22.1126/0**
- 1 x Cover POM-RAL 7012 - **part no. 22.1127/0**
- 4 x pulley carriers ABS blue, **part no. 21.1701/0**
- Length: 120 mm
- Weight = 0.076 kg/piece

APPLICATIONS

- Production of small roller conveyors in connection with profile 45 x 45 R, **part no. 20.1046/0**

ASSEMBLY

- Insert roller carrier in profile
- Insert conveyor rollers
- Clipoff cap

ROLLER CARRIER 45 X 45 R WITH SF COVER

Part no. 22.1152/0

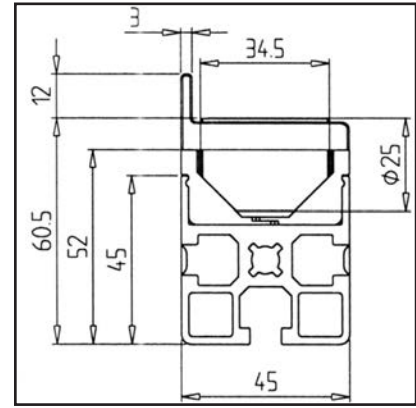
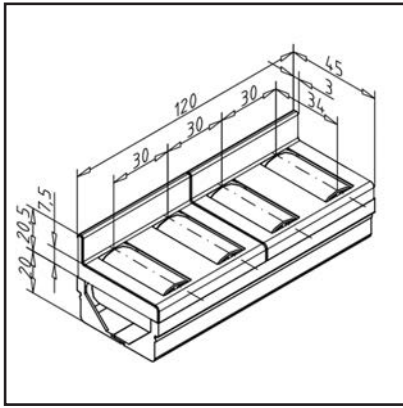

TECHN. DATA / ITEMS SUPPLIED

- POM, grey
- 2 x pulley carriers base part POM-RAL 7012, **part no. 22.1126/0**
- 1 x cover POM-RAL 7012, **part no. 22.1128/0**
- 4 x pulley carriers ABS blue, **part no. 21.1701/0**
- Length: 120 mm
- Weight = 0.083 kg/piece

APPLICATIONS

- Production of small roller conveyors in connection with profile 45 x 45 R, **part no. 20.1046/0**

ASSEMBLY

- Insert roller carrier in profile
- Insert conveyor rollers
- Clipoff cap

CARRIER PROFILE 45 R

Part no. 20.1133/0

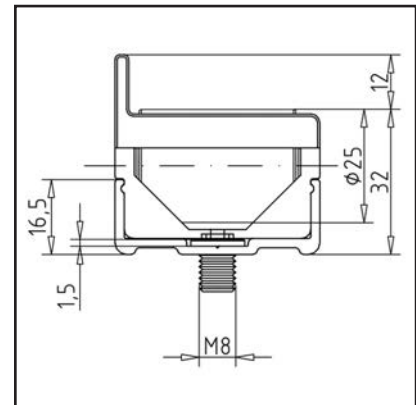
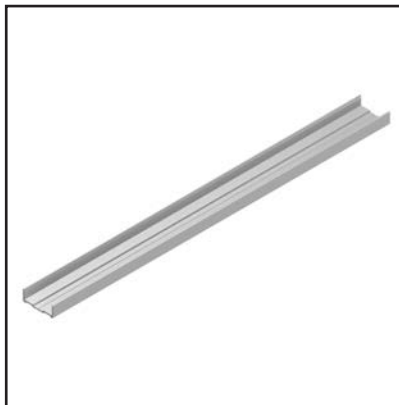
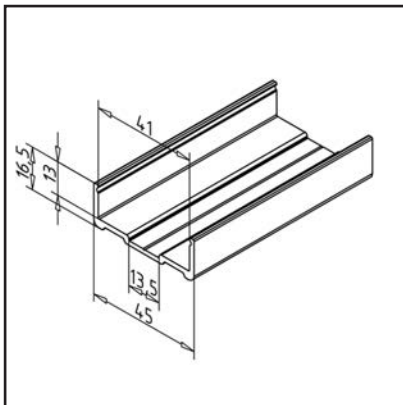

TECHN. DATA / ITEMS SUPPLIED

- Aluminium, anodized E6/EV1
- $I_x = 0.289 \text{ cm}^4$
- $I_y = 0.428 \text{ cm}^4$
- $w_x = 0.128 \text{ cm}^3$
- $w_y = 0.966 \text{ cm}^3$
- Weight = 0.414 kg/m
- Bar length = 6 m

APPLICATIONS

- For the manufacture of miniature roller tracks
- For use with the following roll carriers:
roll carrier 45 x 45R with cover **part no. 22.1151/0**
Roller carrier 45 x 45R with SF cover **part no. 22.1152/0**

ASSEMBLY

- Bore $\phi 8,5$ bring in desired positions
- Assemble with pan head screw **part no. 21.1666/0** and sliding nut 08 with spring sheet **part no. 21.1351/2**
- Put in desired roller carrier

MINIATURE ROLLER STRIP WITH CYL. MINIATURE ROLLER

Part no.

32.0550/0

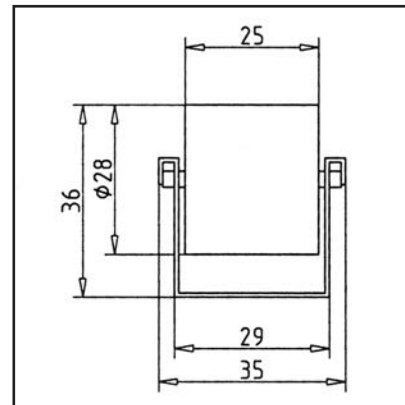
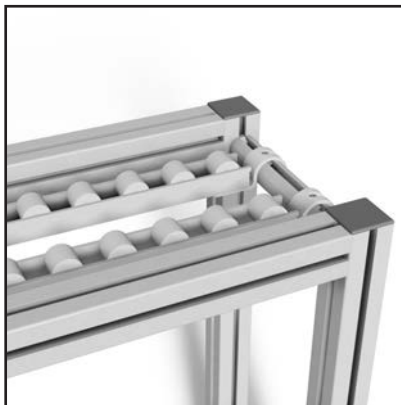
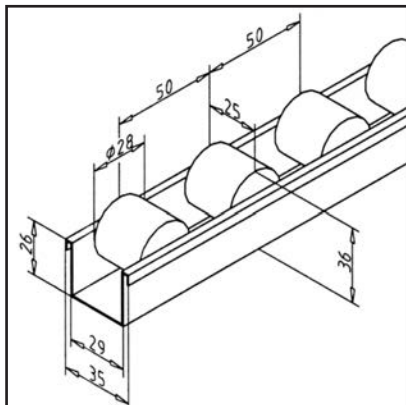

TECHN. DATA / ITEMS SUPPLIED

- Length according to costumers specification
- max. length 6 m
- Division 50 mm
- Supporting profile: Steel, zinc plated
- Roller colour: yellow
- Weight = 0.595 kg/m

APPLICATIONS

- The rollers can be used over a temperature range from -30°C up to +100°C
- **part no. 32.0555/0** highly conductive roller to avoid electrostatic charge. Roller colour: black

ASSEMBLY

- Fasten with fastening **part no. 32.0574/0** and end stop **part no. 32.0569/0** onto profile
- With screws directly on the carrier profile

MINIATURE ROLLER STRIP WITH MINIATURE FLANGE ROLLERS

Part no.

32.0560/0

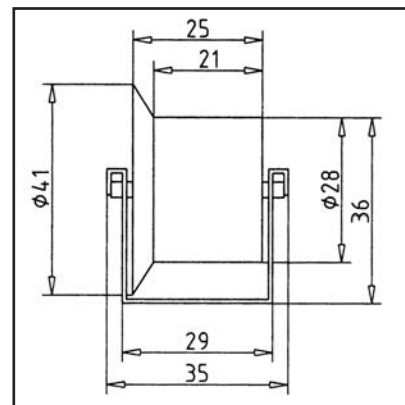
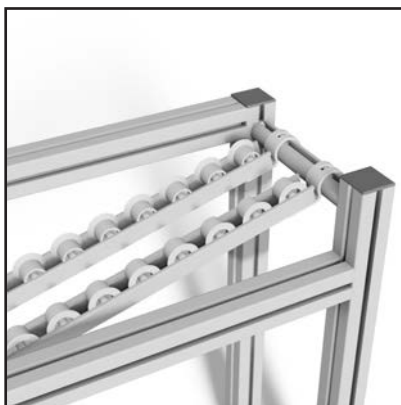
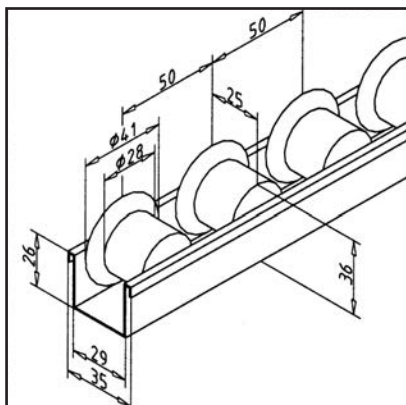

TECHN. DATA / ITEMS SUPPLIED

- Length according to costumers specification
- max. length 6 m
- Division 50 mm
- Supporting profile: Steel, zinc plated
- Roller colour: yellow
- Weight = 0.615 kg/m

APPLICATIONS

- The rollers can be used over a temperature range from -30°C up to +100°C
- **Part no. 32.0565/0** Highly conductive wheels to prevent static charges. Roller colour: black

ASSEMBLY

- Fasten with fastening **part no. 32.0574/0** and end stop **part no. 32.0569/0** onto profile
- With screws directly on the carrier profile

BRACKET FOR MINIATURE ROLLER STRIP 19

Part no.

32.0575/0

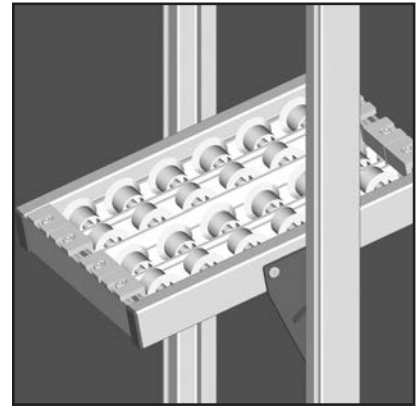
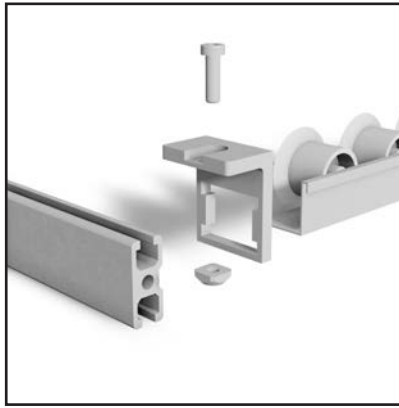
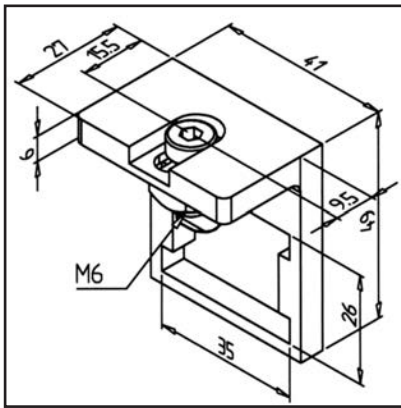

TECHN. DATA / ITEMS SUPPLIED

- Steel, galvanized
- Fastening kit
- Thickness 6 mm
- Weight = 0.095 kg/piece

APPLICATIONS

- For attaching miniature roller strip to profiles 19 and 32
- Holder also serves as bedstop
- also available for profile 30 serie (see **part nr. 32.0575/1**)
- Fitting for all profiles of profile series 45

ASSEMBLY

- Cut out the miniature roller strip
- Insert the miniature roller strip into the holder and screw it to the profile using the fastening material included

BRACKET FOR MINIATURE ROLLER STRIP 30

Part no.

32.0575/1

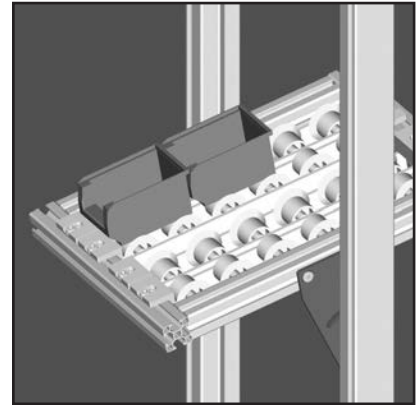
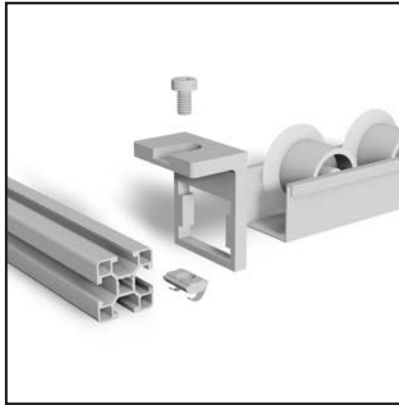
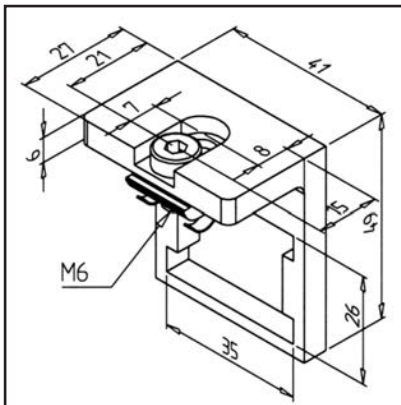

TECHN. DATA / ITEMS SUPPLIED

- Steel, galvanized
- Fastening kit
- Thickness 6 mm
- Weight = 0.092 kg/piece

APPLICATIONS

- For fastening roller bars
- Fitting for all profiles of profile series 30

ASSEMBLY

- Cut out the miniature roller strip
- Insert the miniature roller strip into the bracket; screw it to the profile using the fastening material included

ROLLER STRIP FASTENING

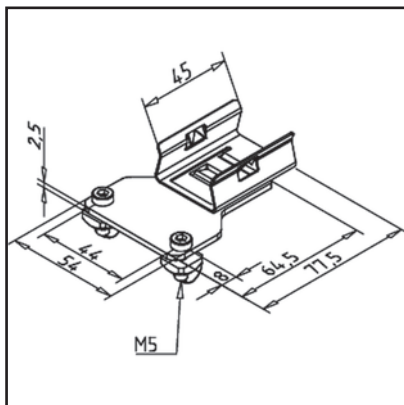

TECHN. DATA / ITEMS SUPPLIED

- Stainless steel
- Thickness 3 mm
- With fastening material and spring clip for miniature roller strip
- Weight = 0.091 kg/piece

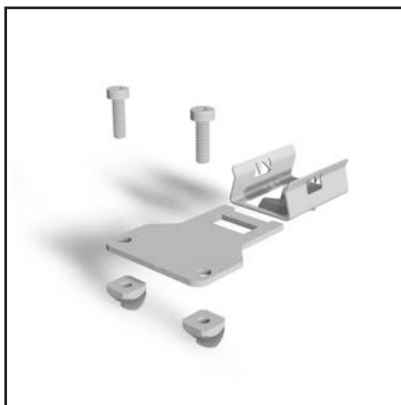

APPLICATIONS

- For attaching miniature roller strip without machining
- Fitting for all profiles of profile series 45

Part no.

32.0574/0

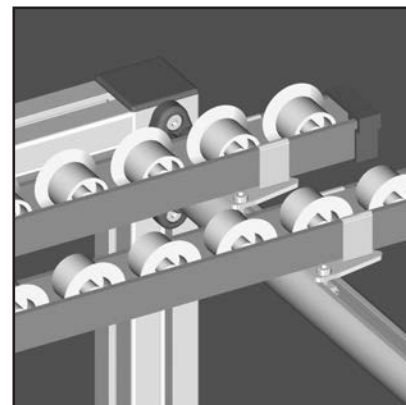

ASSEMBLY

- For roller conveyors use handle profile **part no. 20.1088/0** in connection with flange bearing 32 **part no. 22.1016/0** or clip 32 **part no. 22.1022/0**

END STOP MINIATURE ROLLER STRIP

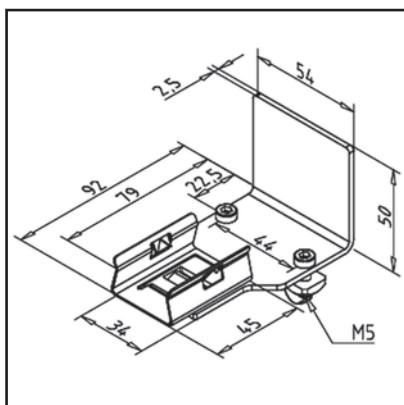

TECHN. DATA / ITEMS SUPPLIED

- Steel
- Stainless steel end stop
- Thickness 3 mm
- With fastening material and spring clip for miniature roller strip
- Weight = 0.166 kg/piece

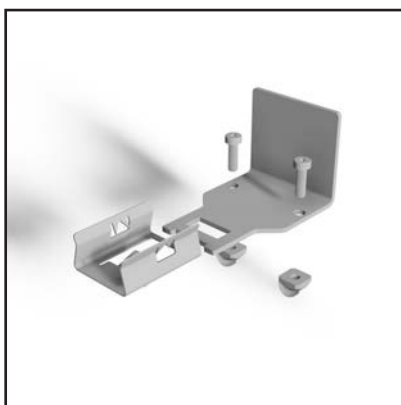

APPLICATIONS

- Use as end stop for miniature roller strip
- Install without drilling
- Fitting for all profiles of profile series 45

Part no.

32.0569/0

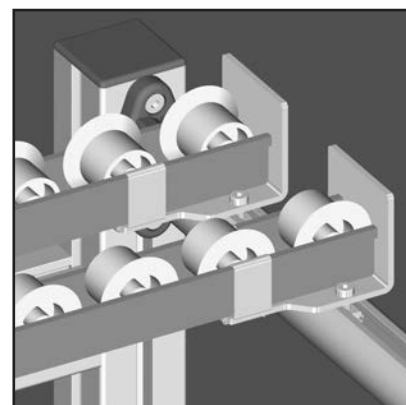

ASSEMBLY

- Fasten to any profile groove with the fastening material provided
- For roller conveyors use handle profile **part no. 20.1088/0** in connection with flange bearing 32 **part no. 22.1016/0** or clip 32 **part no. 22.1022/0**

MINIATURE ROLLER STRIP BRACKET H

Part no. 32.0553/0

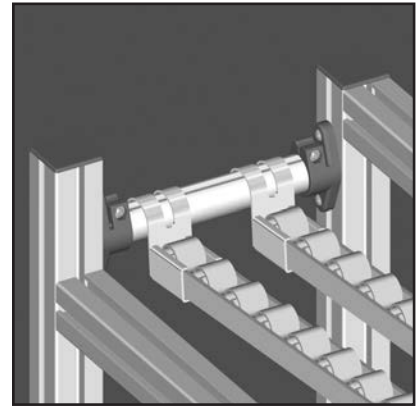
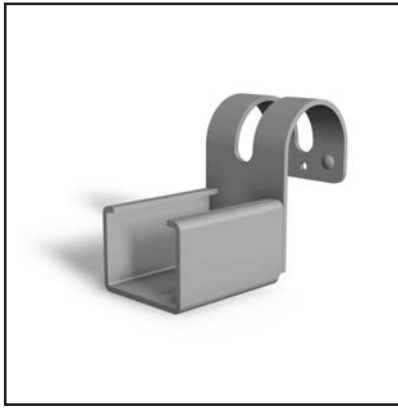
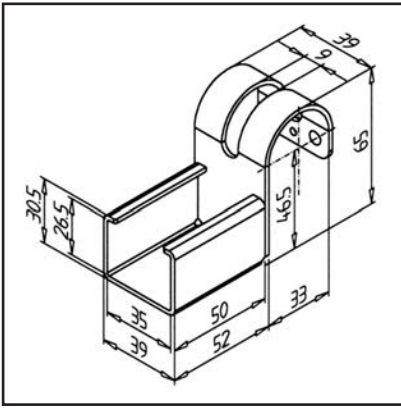

TECHN. DATA / ITEMS SUPPLIED

- Steel, galvanized
- Thickness: 2 mm
- Weight = 0.141 kg/piece

APPLICATIONS

- For attaching roller tracks to grip profile 32
part no.: 20.1088/0
- used as end stop for e.g. containers

ASSEMBLY

- Cut out the miniature roller strip
- Attach bracket to the miniature roller strip
- Hang over handle profile 32
- If necessary, the bracket can be secured with a setscrew

MINIATURE ROLLER STRIP BRACKET F

Part no. 32.0554/0

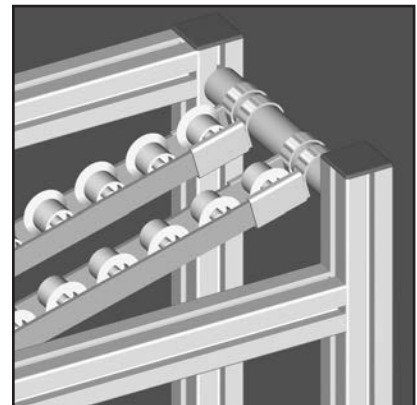
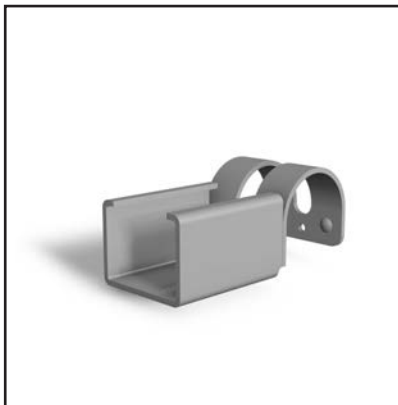
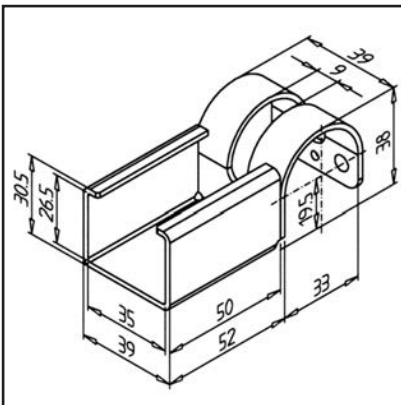

TECHN. DATA / ITEMS SUPPLIED

- Steel, galvanized
- Thickness: 2 mm
- Weight = 0.124 kg/piece

APPLICATIONS

- For attaching roller tracks to grip profile 32
part no.: 20.1088/0
- Height of edges on the bracket corresponds the travelling height of rollers

ASSEMBLY

- Cut out the miniature roller strip
- Attach bracket to the miniature roller strip
- Hang over handle profile 32
- If necessary, the bracket can be secured with a setscrew

FLANGE BEARING 32

Part no.

22.1016/0

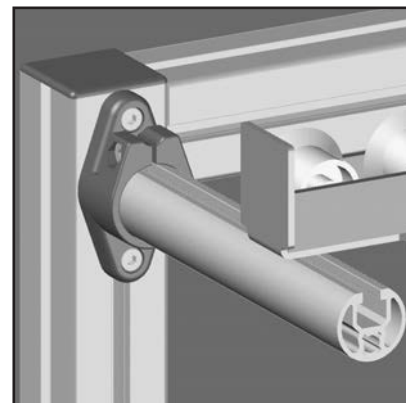
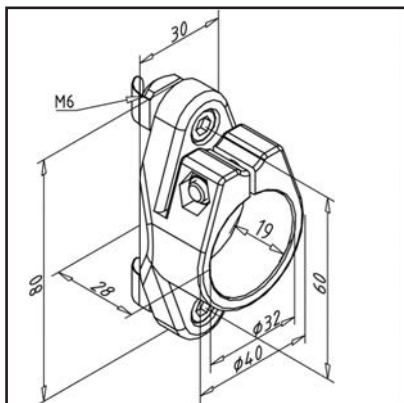

TECHN. DATA / ITEMS SUPPLIED

- ABS, grey
- Fastening kit
- Weight = 0.050 kg/piece

APPLICATIONS

- For angle-adjustable assembly of handle profile 32 for roller track **part no. 20.1088/0**

ASSEMBLY

- Use fastening kit to fasten to base frame
- Push in handle profile 32 and clamp using screws

GRIP PROFILE CLAMP 32

Part no.

22.1022/0

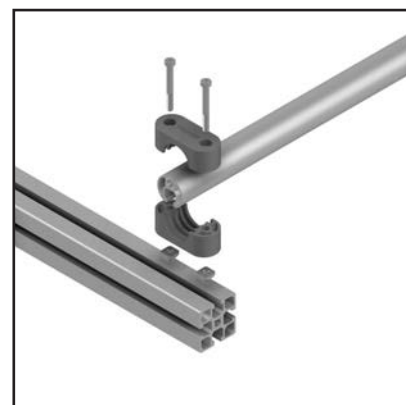
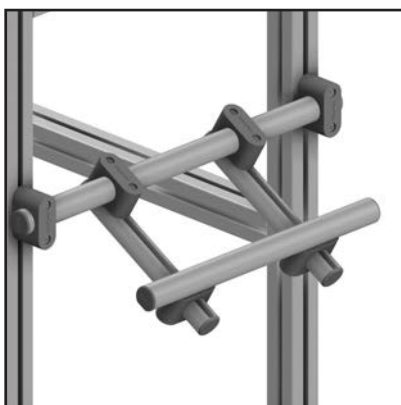
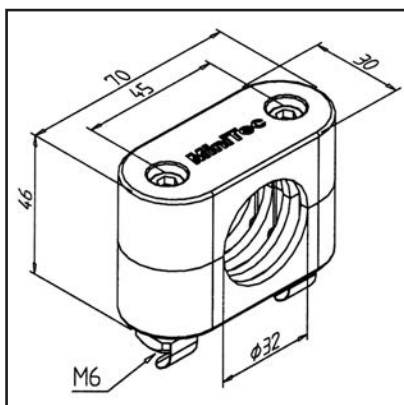

TECHN. DATA / ITEMS SUPPLIED

- ABS, grey
- Fastening kit
- Weight = 0.036 kg/piece

APPLICATIONS

- For handle profile 32 **part no. 20.1088/0**
- Handle with adjustable angle
- Simple equipment and frames

ASSEMBLY

- Swivel the sliding nuts
- Insert handle profile into the 2 half-shells
- Fasten with screws

CATCH 32 FOR HANDLE PROFILE

Part no.

21.0005/0

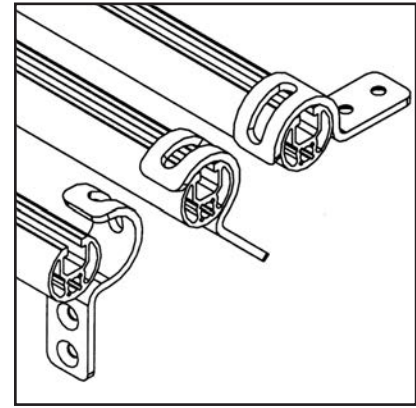
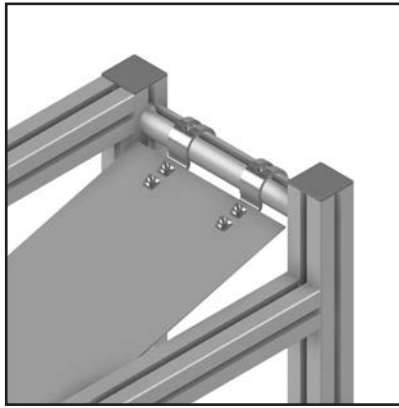
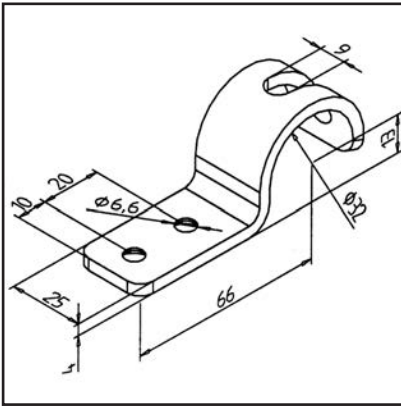

TECHN. DATA / ITEMS SUPPLIED

- Steel, galvanized
- Countersunk screw M6 x 16
- With sliding nut M6
- Weight = 0.100 kg/piece

APPLICATIONS

- Angle-independent attachment of roller conveyors, plates, shelves, etc. on the handle profile 32nd **part no. 20.1088/0**

ASSEMBLY

- Attach plates or similar with M6 countersunk screw
- Hang over handle profile 32
- If necessary, secure against dislocation with set screw M8 x 20 and sliding nut M8

EDGE PROTECTION

Part no.

32.0572/0

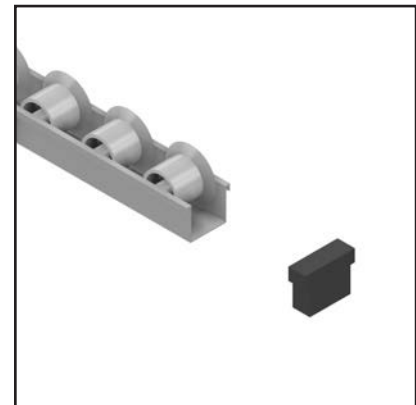
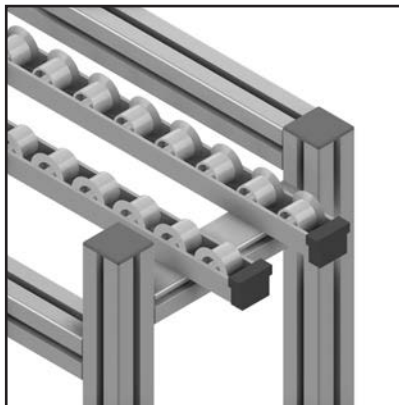
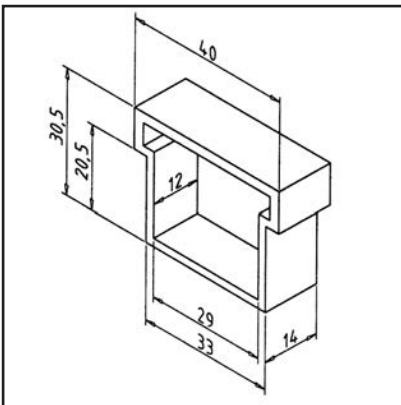

TECHN. DATA / ITEMS SUPPLIED

- Plastic, black
- ESD-compatible
- Weight = 0.004 kg/piece

APPLICATIONS

- Protection against injury

ASSEMBLY

- Attach to the miniature roller strip

BRAKE PLATE

Part no.

32.0571/0

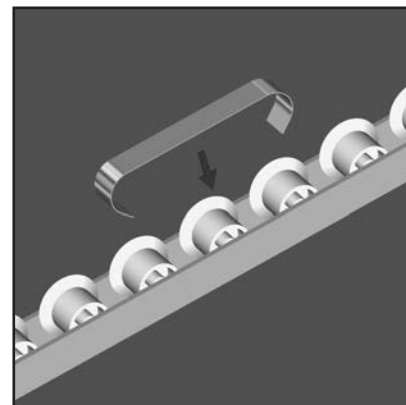
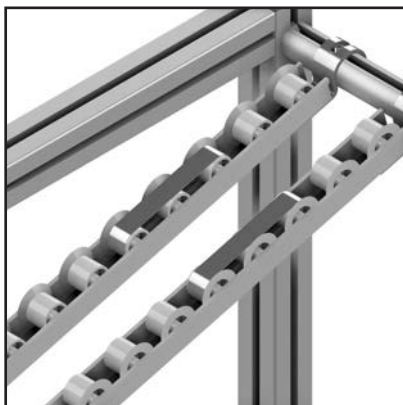
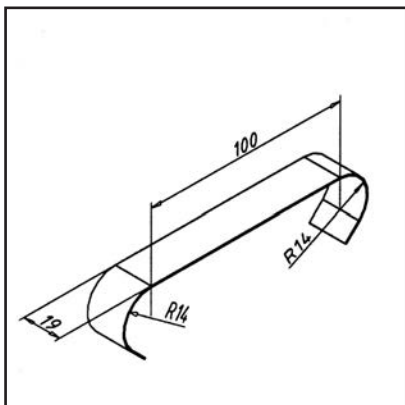
**TECHN. DATA / ITEMS SUPPLIED**

- Steel
- Brake plate on spring steel for 50 mm division
- In connection with conductive roller ESD conductive
- Weight = 0.017 kg/piece

APPLICATIONS

- The brake plate can be fastened at any desired location

ASSEMBLY

- Attach to the miniature roller strip

MINIATURE ROLLER BRAKE

Part no.

32.0562/0

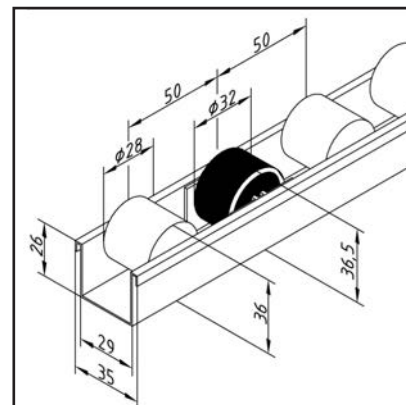
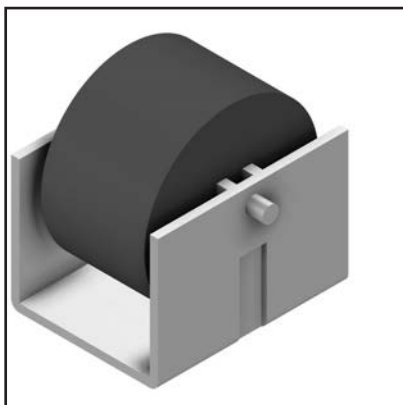
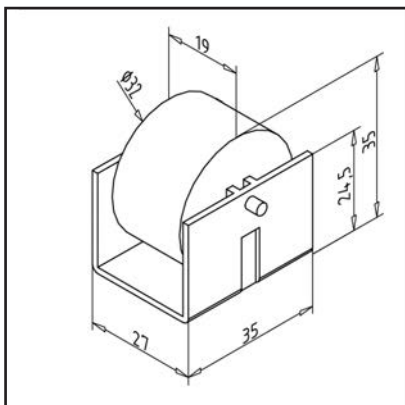
**TECHN. DATA / ITEMS SUPPLIED**

- Plastic, black
- Weight = 0.022 kg/set

APPLICATIONS

- For use with roller rails with a slope, for braking the conveyed material

ASSEMBLY

- Remove the existing miniature rollers from the roller strip
- insert support at the same place and clip brake-roller in
- When installing, pay attention to the direction of the bracket and the miniature rollers

BALL ROLLER

Part no.

35.0041/0

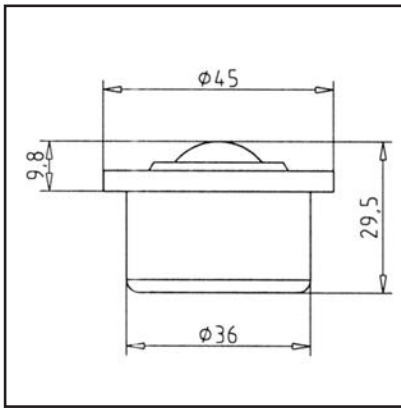
**TECHN. DATA / ITEMS SUPPLIED**

- Housing made of steel sheet, galvanized, steel balls
- DW 22,2 mm
- Load factor C 1200 N
- Weight = 0.130 kg/piece

APPLICATIONS

- Ball rollers for conveyor systems and automation systems
- Enable a simultaneous longitudinal and transverse movement
- Installation in work tables or roller tracks
- Ball roller also as suspension for boxes, devices, furniture and appliances

ASSEMBLY

- Insert into prepared bore
- Or install with tolerance ring **part no. 35.0001/0**
- Caution: for mounting with tolerance ring of other bore diameter ($37.7 + 0.2$ mm)

The optimal working height - also with the material supply.

The lifter ensures ergonomic conditions in the workplace, because during loading and unloading the containers automatically remain in the optimum position and height for the respective worker. The working height can be adjusted continuously and remains the same even with different height

containers. This is ensured by an easily adjustable precision reflex switch. A removable control panel as well as various loading options ensure flexibility and user-friendliness.

Lifter 1000



Lifter 1400



Example application Lifter 1000 with equipment - lateral loading

Example application Lifter 1400 with equipment - frontal loading

	Lifter 1000	Lifter 1400
Dimensions (without fork) W x H x D	560 x 1382 x 283 mm	560 x 1782 x 283 mm
Gabelhubhöhe	115 bis 1000 mm	115 bis 1400 mm
Max. Load capacity	200 kg	200 kg
Max. Lifting speed	< 40 mm/s	< 40 mm/s
Supply	230V / 50Hz, 10A	230V / 50Hz, 10A
Protection	IP54 IEC 529	IP54 IEC 529
Part no.	32.1560/0	32.1561/0
Lifter HD for loads up to 1,000 kg on request (also with Euro pallet holder)		

TECHNICAL DATA

- Electric geared motor with brake
- Low-maintenance ball screw
- Automatic height recognition
- Automatic loading and unloading mode
- Removable manual control panel ensures flexibility and user-friendliness
- Siemens logic module
- Surface powder-coated resp. galvanized
- Easily adjustable proximity switch ensures optimum working height
- Low space requirements
- Quick adjustment of the desired working height
- Simple connection to a 230V/50 Hz socket
- With tool-free mounting of the accessories, various loading variants can be implemented quickly and easily

Simple and flexible to the right configuration for your application.

Simply choose the lifter suitable for your needs (stroke 1000 or 1400mm) and equip it with the accessories necessary for your application.



Possible loading variants

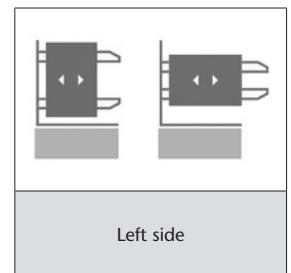
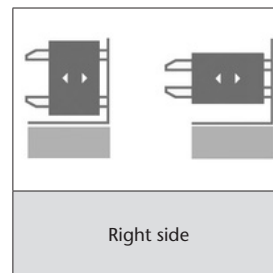
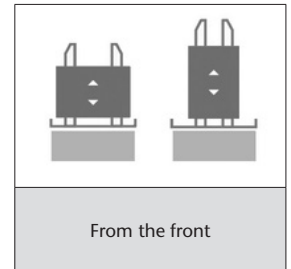





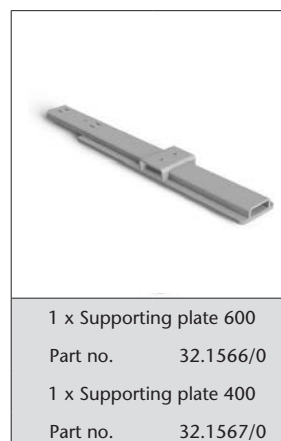
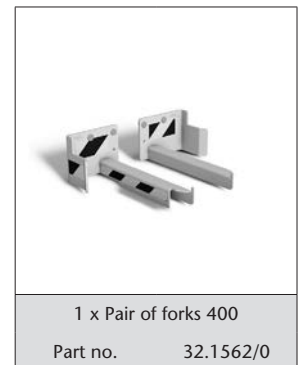
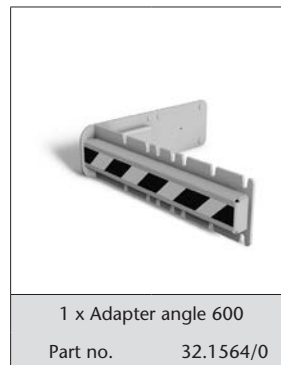
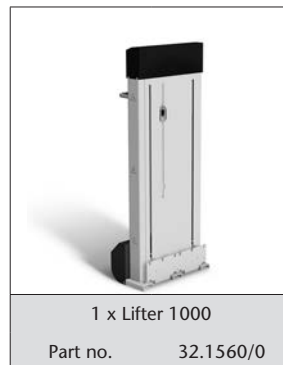





Depending on the loading variant you need at least one pair of forks in addition to the lifter, possibly an adaptation angle and one or two support plates.

Ordering example for a Lifter 1000 with side loading left / right as shown



Loading variants with fork pair, support plate and adaptation angle combinations







	Pair of forks 400	Pair of forks 600	Adapter angle 400	Adapter angle 600	Supporting plate 400	Supporting plate 600
	Part no. 32.1562/0	Part no. 32.1563/0	Part no. 32.1565/0	Part no. 32.1564/0	Part no. 32.1567/0	Part no. 32.1566/0
						
	X				X	
		X				X
	X			X	X	X
		X	X		X	X
	X			X	X	X
		X	X		X	X

Overview accessories

Due to the additional adjustment options - lateral and longitudinal - the lifter is suitable for the use of a wide variety of floor scooters and material trolleys.

Optional equipment for the lift is available:

- Increase for proximity switch
- Different sensors for height detection
- Various adaptations for various floor rollers
- Specially adapted fork pairs / load holders

<p>Adapter angle It allows lateral loading.</p>		<p>Adapter bracket 400 Part no. 32.1565/0</p> <p>Adapter angle 600 Part no. 32.1564/0</p>
<p>Fork pairs Depending on size and load variant Fork pair 400 or 600.</p>		<p>Pair of forks 400 Part no. 32.1562/0</p> <p>Pair of forks 600 Part no. 32.1563/0</p>
<p>Support plates Provide the safe position of the lift even with heavy loads.</p>		<p>Supporting plate 400 Part no. 32.1567/0</p> <p>Supporting plate 600 Part no. 32.1566/0</p>
<p>Floor roller The transport floor roller is made of sheet steel and has a double edge.</p> <p>Load capacity up to 450 kg Track width: 305 or 318</p>		<p>Trolley 400 x 600, gauge 305 Part no. 32.1569/0</p> <p>Trolley 400 x 600, track width 318 Part no. 32.1570/0</p> <p>ESD version: Floor roller 400 x 600, track width 305 Part no. 32.1571/0</p>
<p>Hand drawbar / drawbar cart For easy transport the floor roller. In combination with the towing eye and drawbar, a ground roller train can be formed.</p>		<p>Hand draw Part no. 32.1572/0</p> <p>Pedestrian cart Part no. 32.1573/0</p>
<p>Magnetic control panel holder With magnets, it can be flexibly attached to the appropriate place of the lift cover. Above, on the side or on the back.</p>		<p>Control panel holder magnetic Part no. 32.1568/0</p>
<p>Boxes</p>		<p>Box 600 (L) x 400 (W) x 150 (H) Part no. 32.1574/0</p> <p>Box 600(L) x 400(B) x 236(H) Part no. 32.1575/0</p> <p>Box 600(L) x 400(B) x 420(H) Part no. 32.1576/0</p>

ASSEMBLY DEVICES

In the development of assembly devices it is important to not only reduce set-up times but also to increase reusability, i.e. flexibility. In combination with the Minitec profile system, adaptability to different workpieces is always guaranteed with minimal changeover effort and time.

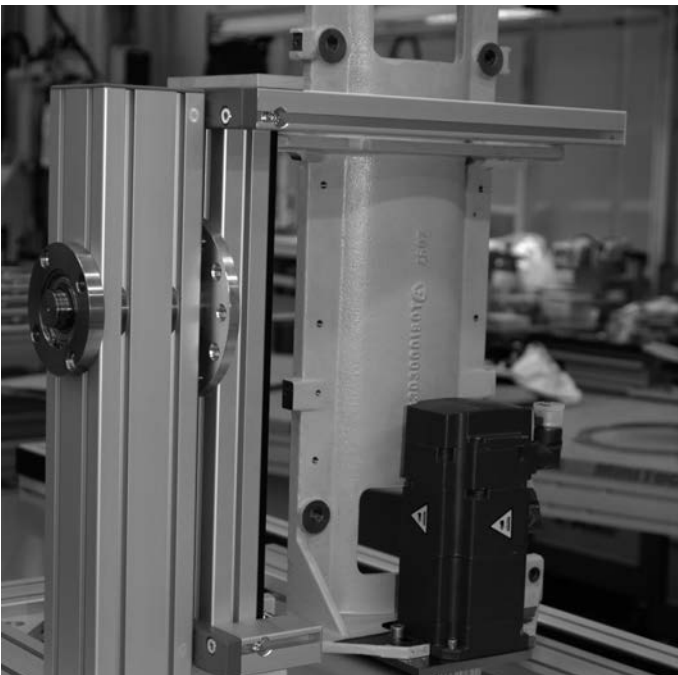

TURNING DEVICE 45 X 90

Part no.

32.2011/0

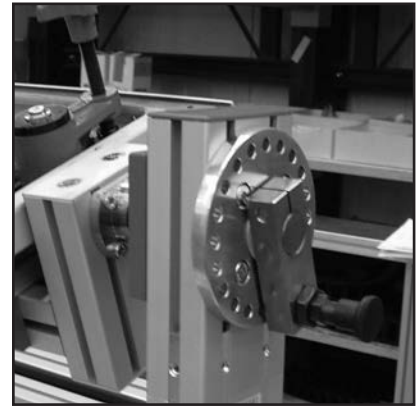
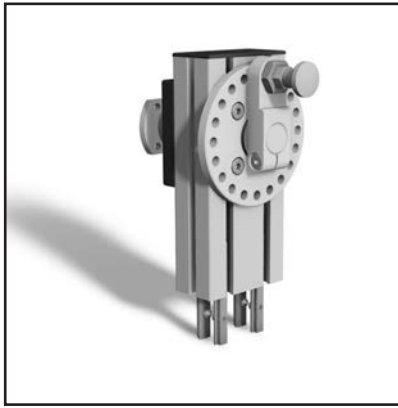
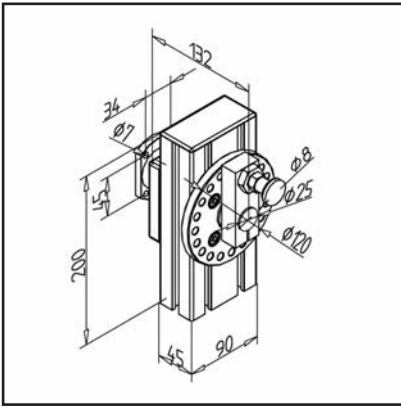

TECHN. DATA / ITEMS SUPPLIED

- Fmax. 1500 N
- Mmax. 150 Nm
- Screening 18°
- Indexing bolt with lock
- Bearing over 2 sliding bushings
- Weight = 3.320 kg/piece

APPLICATIONS

- Reproducibly accurate positioning of components for assembly purposes
- Remote controlled pneumatic locking on request

ASSEMBLY

- Fastening with clamping strip as profile extension or profile connector
- Clearance and turning position adjustable using clamp connection

TURNING DEVICE 90X90

Part no.

32.2010/0

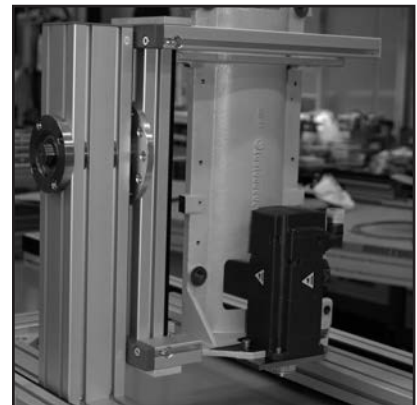
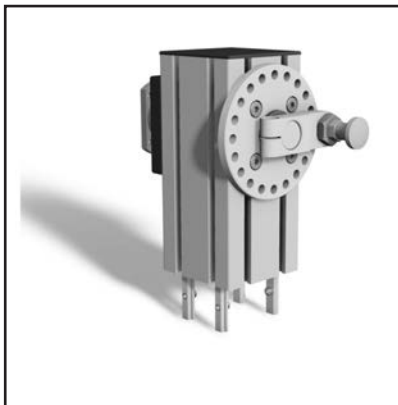
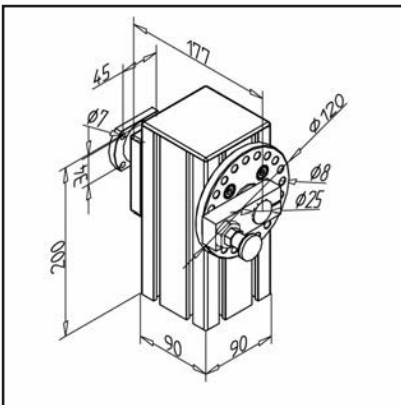

TECHN. DATA / ITEMS SUPPLIED

- Fmax. 1500 N
- Mmax. 150 Nm
- Screening 18°
- Indexing bolt with lock
- Bearing over 2 sliding bushings
- 4 T-slot bars for installation on profile construction
- Weight = 4.374 kg/piece

APPLICATIONS

- Reproducibly accurate positioning of components for assembly purposes
- Remote controlled pneumatic locking on request

ASSEMBLY

- Fastening with clamping strip as profile extension or profile connector
- Clearance and turning position adjustable using clamp connection

SLEWING RING 330 / 260 / 14 MM

Part no.

32.2005/1

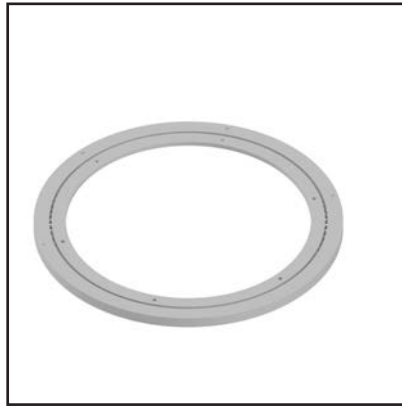
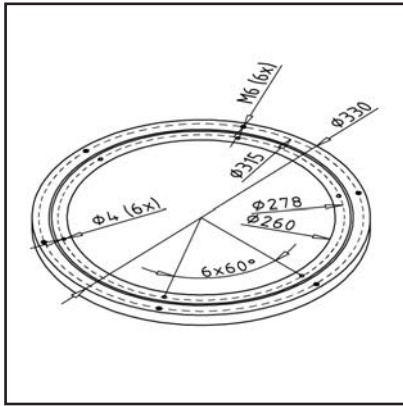
**TECHN. DATA / ITEMS SUPPLIED**

- Aluminium, Pressure die-casting, blasted
- Turntable with steel balls
- Axial load up to 300 kg
- ESD-compatible
- Ø 330 x 13.5 mm
- Low maintenance
- Circular aluminum blanks upon request
- Weight = 0.580 kg/piece

APPLICATIONS

- Used in the industry, in furniture display construction, simple turning device for mounting devices for horizontal use

ASSEMBLY

- Screw through the holes D = 4 mm onto the profile frame or the table plate
- Screw turntable or similar onto the outer ring

LOCKING BOLT ADJUSTMENT F

Part no.

29.0852/0

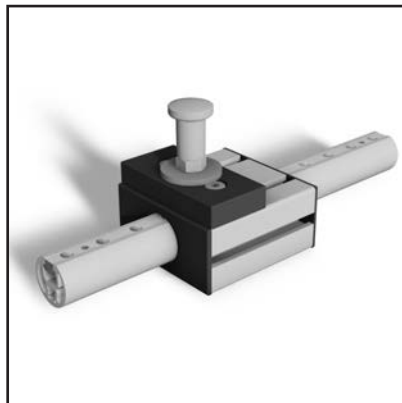
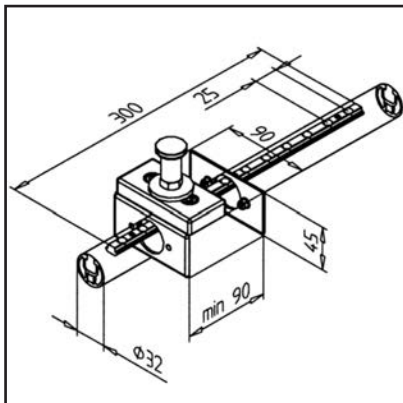
**TECHN. DATA / ITEMS SUPPLIED**

- Locking bolt with rest position
- Drilled clamping strip for detent with step 25 mm, length 300 mm
- End caps
- Connecting plate for receiving the locking bolt
- Profile 45 x 90S machined **part no. 29.0857/0** and handle profile **part no. 20.1088/0** not included in delivery scope
- Weight = 0.460 kg/piece

APPLICATIONS

- for height-adjustable tables, conveyors etc.
- for lock in place adjustment of lateral guides
- for adjustable devices and clampings

ASSEMBLY

- fasten perforated t-slot bar onto handle profile 32
- Insert the locking bolts in the connection plate and profile 45 x 90 S
- **please indicate length of handle profile 32 (min. 300 mm) and profile 45x90S (min. 90 mm)!**

LOCKING BOLT ADJUSTMENT H

Part no. 29.0851/0

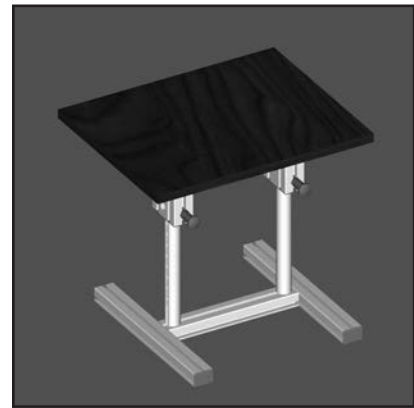
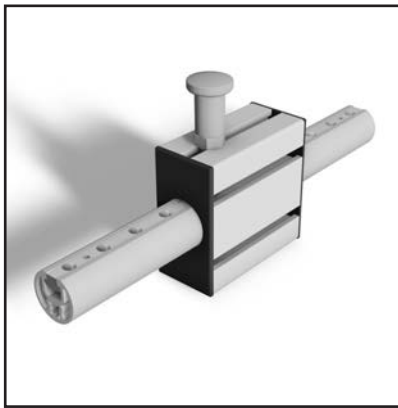
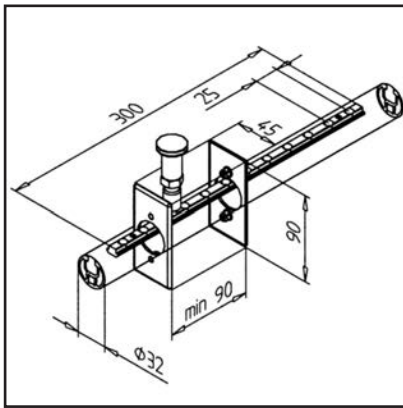

TECHN. DATA / ITEMS SUPPLIED

- Locking bolt with rest position
- Drilled clamping strip for detent with step 25 mm, length 300 mm
- End caps
- Profile 45 x 90S machined **part no. 29.0858/0** and handle profile 32 **part no. 20.1088/0** not included in delivery scope
- Weight = 0.241 kg/piece

APPLICATIONS

- for height-adjustable tables, conveyors etc.
- for lock in place adjustment of lateral guides
- for adjustable devices and clampings

ASSEMBLY

- fasten perforated t-slot bar onto handle profile 32
- Screw in the locking bolts in profile 45 x 90 S
- **please indicate length of handle profile 32 (min. 300 mm) and profile 45x90S (min. 90 mm)!**

UNIVERSAL CLAMPING SOCKET

Part no. P2.0060/0

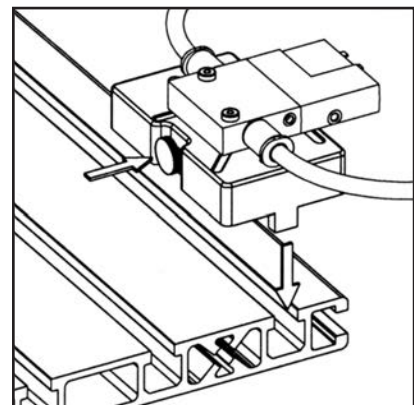
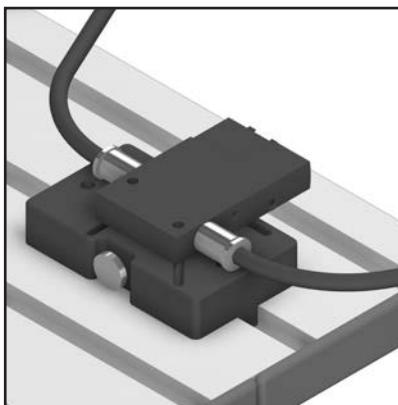
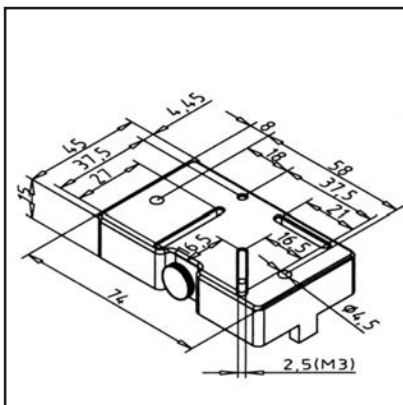

TECHN. DATA / ITEMS SUPPLIED

- Housing PA 6 GF
- Actuator made of steel
- Weight = 0.037 kg/piece

APPLICATIONS

- For assembly of pneumatic switches for learning and training purposes
- To fasten diverse pneumatic switches
- Mounting of valves or similar from various manufacturers

ASSEMBLY

- Simple pneumatic accessories fastened with M3 screws (not in scope of delivery) onto the clamping socket
- By pressing the button, the clamping socket can be fit into the slot
- When released, an automatic locking takes place

ESD-ACCESSORIES



ESD (Electro Static Discharge) is the electrostatic discharge of charged objects or persons by direct contact or sparks. The cause of ESD are electrical charges which are generated by charge separations or as a result of influences in electrical fields. Sources of this charge may be people and their clothes

- workplace equipment including floors,
- packaging equipment and tools

Electrostatically sensitive devices, especially semiconductor components

Protective measures for electrostatically sensitive components

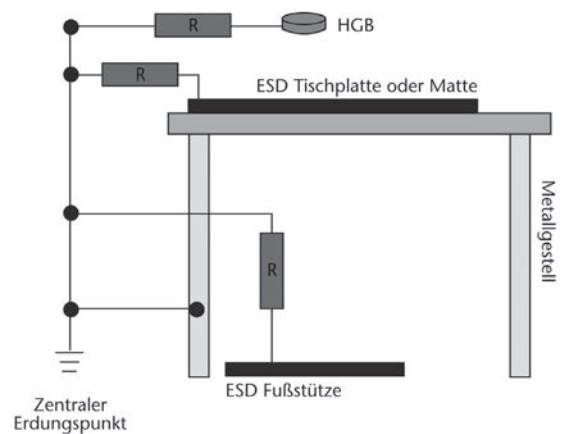

To ensure safe protection of electrostatically sensitive components and devices in practice, all components must be conductively connected to one another and the entire construction must be earthed. The individual components are illustrated using the example of a MiniTec system workstation.

EARTHING BOX ESD

Part no.

32.1002/0

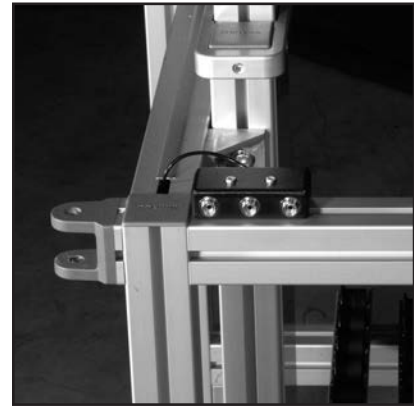
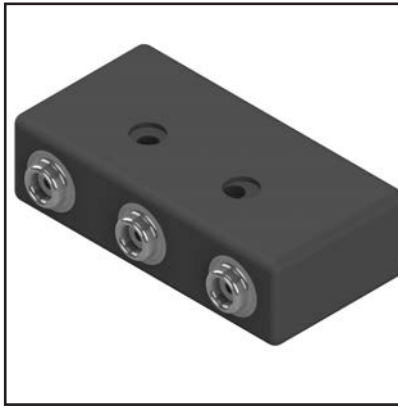
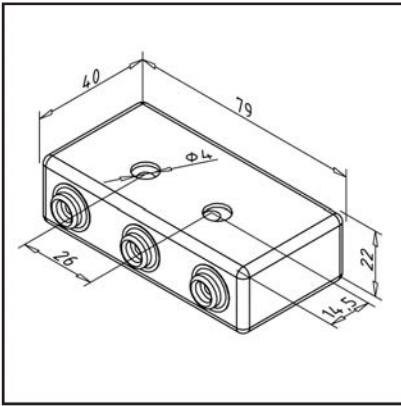

TECHN. DATA / ITEMS SUPPLIED

- Earthing cable 2 m length
- Connection type: 4mm eye
- 1 MOhm safety resistor per connection
- 3x 10 mm push button connection
- Weight = 0.061 kg/piece

APPLICATIONS

- Earth connection point EBP for personnel grounding

ASSEMBLY

- Tighten to table plate with chipboard screw $\varnothing 4 \times 30$
- Fix with cyl. screw M4 x 30 **part no. 21.1285/0** and 2x square nut M4 **part no. 21.1310/2** onto profile

EARTH CONDUCTOR ESD

Part no.

32.1004/0

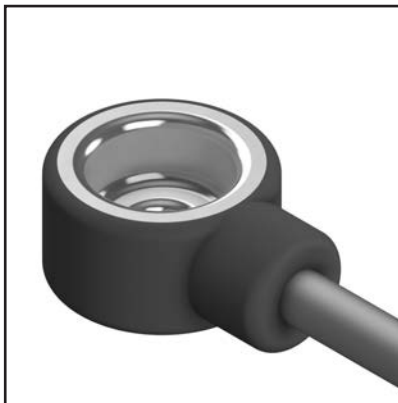
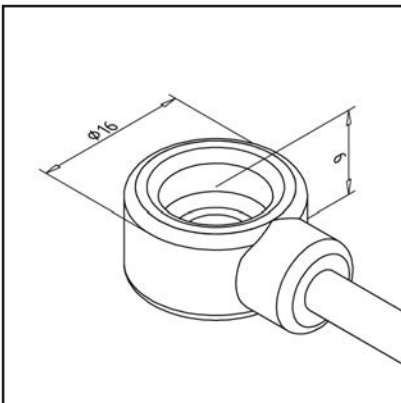

TECHN. DATA / ITEMS SUPPLIED

- 1 MOhm safety resistance
- 10 mm push button / 4 mm eye
- Length: 3 m
- Weight = 0.019 kg/piece

APPLICATIONS

- For table and floor coverings

ASSEMBLY

- Connect as central grounding **part no. 32.1003/0** box ESD
- Clip onto table pad

CENTRAL EARTHING BOX ESD

Part no.

32.1003/0

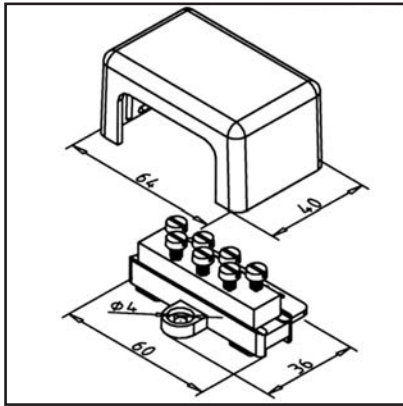
**TECHN. DATA / ITEMS SUPPLIED**

- Terminal strip for connection of max. 7 earthing cables
- With screw connections for lugs with 4 mm eye
- Weight = 0.072 kg/piece

**APPLICATIONS**

- Suitable for contacting earthing conductors to ESD or protective ground

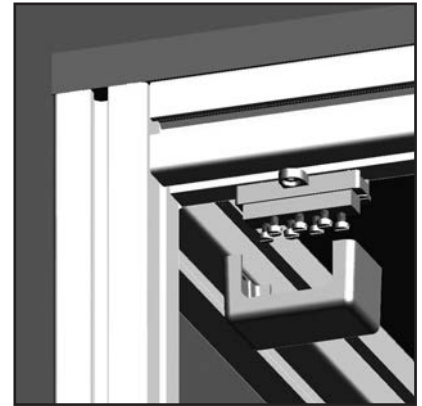
**ASSEMBLY**

- Attach to the tabletop with accessories from scope of supply

DUMMY PLUG WITHOUT RESISTOR

Part no.

32.1001/0

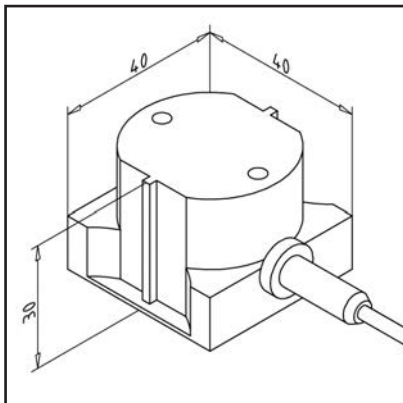
**TECHN. DATA / ITEMS SUPPLIED**

- Dummy plug for Schuko outlet
- With 2m smooth cable
- Connection type: 4mm eye
- Weight = 0.048 kg/piece

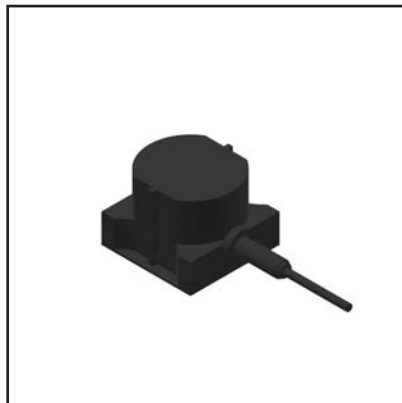
**APPLICATIONS**

- For direct earthing of tabletops and floor coverings or the central earthing strip

**ASSEMBLY**

- Connect to central grounding box **part no. 32.1003/0**
- Plug into suitable Schuko outlet

SPIRAL CABLE HIGHLY ELASTIC

Part no.

32.1017/0



TECHN. DATA / ITEMS SUPPLIED

- Spiral cable; highly elastic, black
- 10mm / 10mm pushbutton
- 1 MOhm
- Length: 1,80 m
- Weight = 0.041 kg/piece

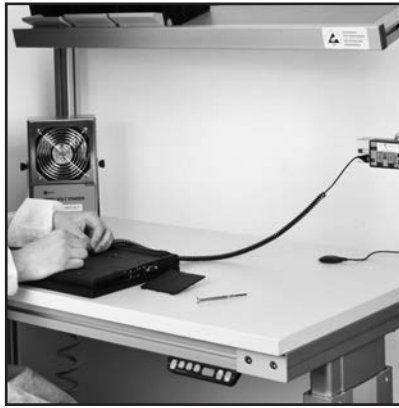

APPLICATIONS

- For connecting wristlets onto earthing box

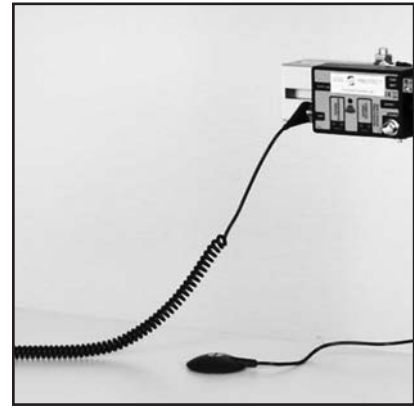

ASSEMBLY

- Fasten spircal cable with push button onto earthing box and wristlet

ELASTIC WRIST STRAP

Part no.

32.1018/0



TECHN. DATA / ITEMS SUPPLIED

- Wristlet blue
- Push-button 10mm
- Weight = 0.013 kg/piece



APPLICATIONS

- Earthing of humans



ASSEMBLY

- Attach to the wrist and connect to the grounding box via spiral cable

EARTHING CABLE ESD AREA

Part no.

32.1013/0

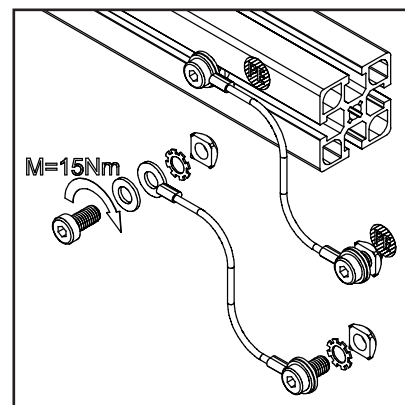
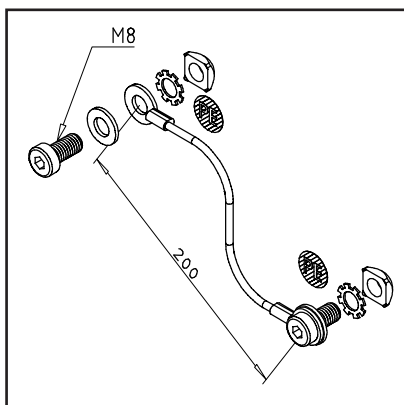
**TECHN. DATA / ITEMS SUPPLIED**

- Earthing cable for ESD areas
- Core H07V-K 4mm² Length: 200 mm
- Weight = 0.053 kg/piece

APPLICATIONS

- For earthing work tables and structures between profile and profile
- For earthing of work tables and constructions between profiles and panel element

ASSEMBLY

- Fasten both sides with M8
- Fasten to profile groove with supplied hardware.

EARTHING POINT

Part no.

32.0769/0

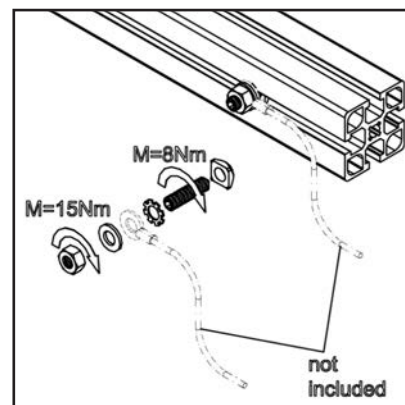
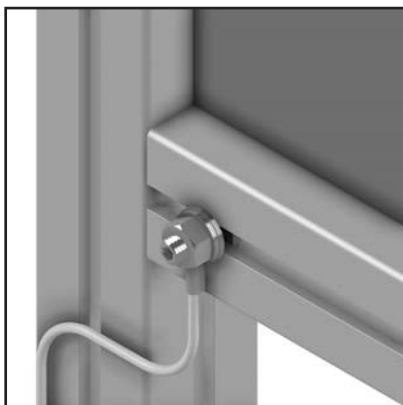
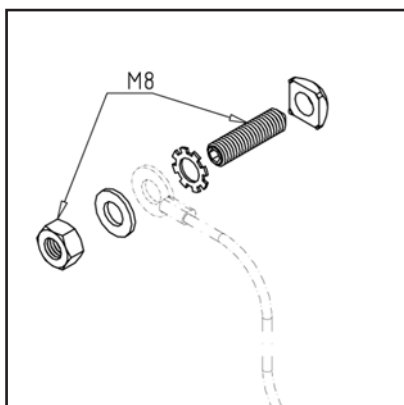
**TECHN. DATA / ITEMS SUPPLIED**

- Threaded pin M8x30
- Sliding nut - Z M8
- Tooth lock washer
- washer
- hexagon nut
- Weight = 0.022 kg/piece

APPLICATIONS

- For earthing workstations and constructions

ASSEMBLY

- Mount in the profile groove according to the enclosed installation drawing

HANDLE 120 ESD, BLACK

Part no.

32.1007/0

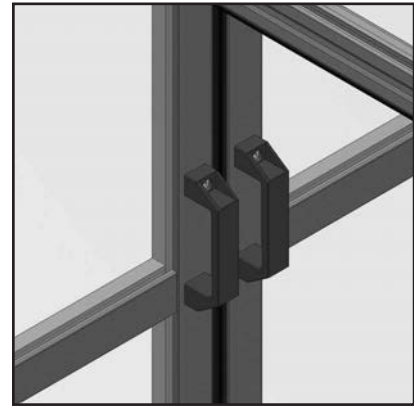
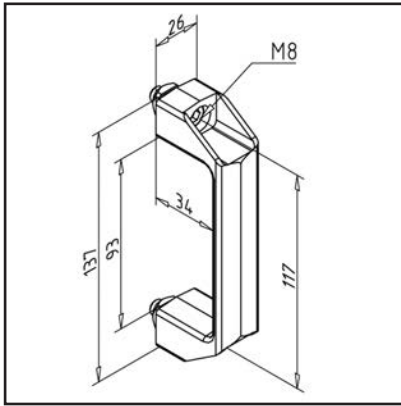

TECHN. DATA / ITEMS SUPPLIED

- PA, black
- Fastening kit
- Weight = 0.073 kg/piece

APPLICATIONS

- Doors
- Lids
- Guard units

ASSEMBLY

- Fasten to profile groove with supplied hardware.
- Directly on surface element with cylinder head screw M8
- Also assembly possible from rear side

CONNECTING PLATE 45X90, CONDUCTIVE

Part no.

21.1472/6

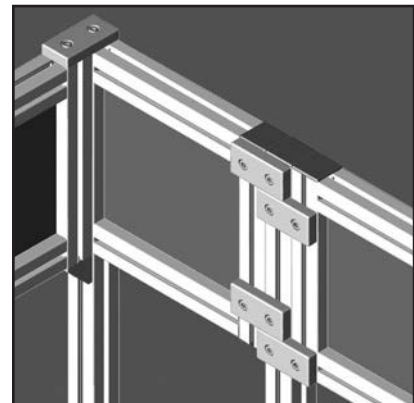
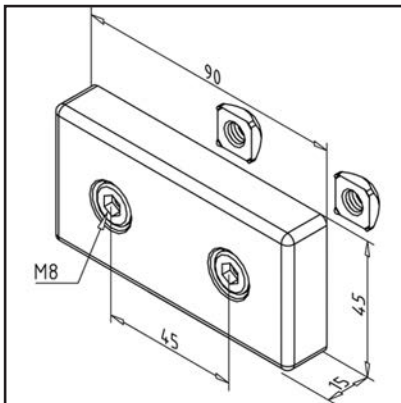

TECHN. DATA / ITEMS SUPPLIED

- Aluminium, Pressure die-casting, bright
- With fastening material steel, zinc plated
- Weight = 0.180 kg/piece

APPLICATIONS

- Connection of two guards without gap
- Strengthening of guard units
- Connection of pre-assembled modules

ASSEMBLY

- Install to groove of protective field and posts with supplied hardware

EARTHING CLAMP

Part no.

E9.0141/0

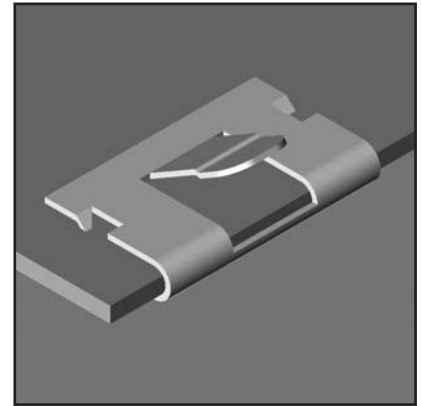
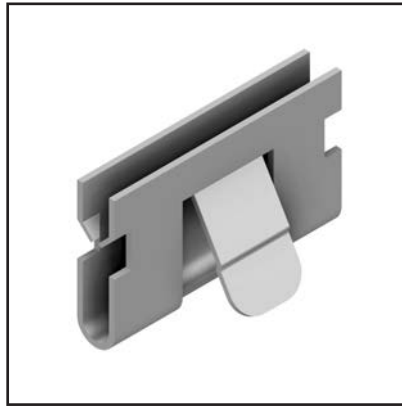
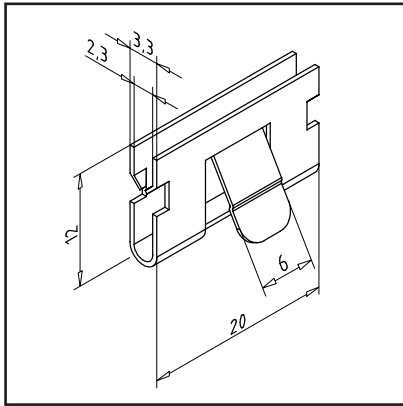
**TECHN. DATA / ITEMS SUPPLIED**

- Steel, Pressed, galvanized
- Weight = 0.002 kg/piece

APPLICATIONS

- For grounding sheet metal and thin-walled components with wall thickness of 0.7 - 2 mm
- Especially suitable for:
 - Cable duct AL **part no. 20.1051/0**
 - Cable duct 45 AL **part no. 20.1071/0**
 - Cable duct 90 AL **part no. 20.1056/0**

ASSEMBLY

- Attach to sheet metal edge
- Safe support and conductive connection is provided by claws
- For the connection of the earthing cable with 6 mm flat plug

MOUNTING ANGLE 19 GD-Z CONDUCTIVE

Part no.

21.2078/6

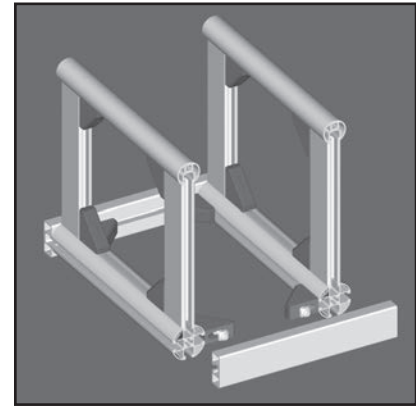
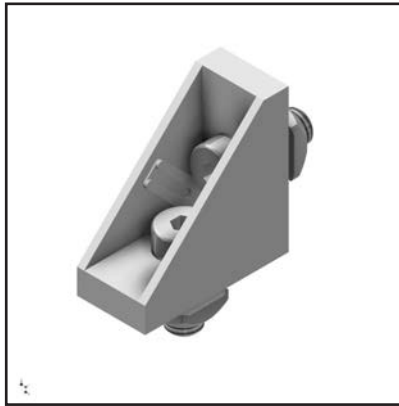
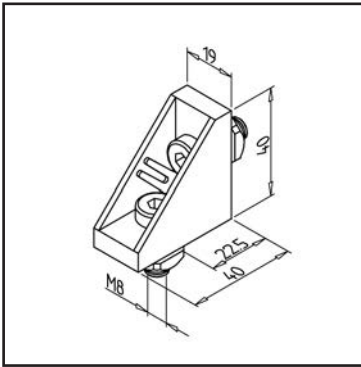
**TECHN. DATA / ITEMS SUPPLIED**

- Aluminium, Pressure die-casting, blasted
- With fastening material steel, zinc plated
- Aluminium GD-Z
- Weight = 0.055 kg/piece

APPLICATIONS

- Connection of profiles 19 and 32
- Subsequent insertion of profiles into existing constructions
- Attaching bearing surfaces
- Slidable in the groove direction

ASSEMBLY

- Fasten to profile groove with supplied hardware
- For subsequent mounting on vertical nut, a square nut M8 Z with nut fixation, **part no. 21.1390/2** is preferred
- Recommended locking torque: 20 Nm

MOUNTING ANGLE 25 GD-Z CONDUCTIVE

Part no.

21.0969/6

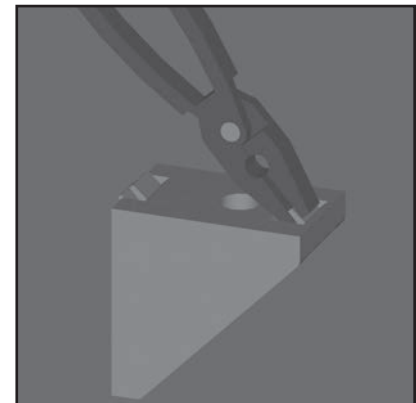
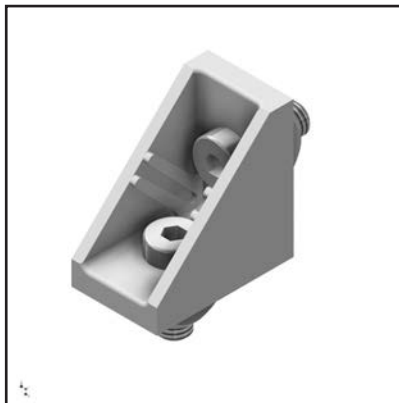
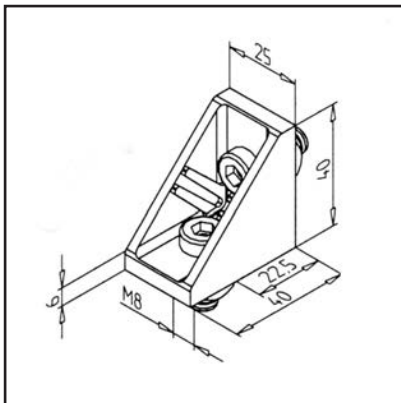
**TECHN. DATA / ITEMS SUPPLIED**

- Aluminium, Pressure die-casting, blasted
- With fastening material steel, zinc plated
- Removable centering tabs
- Weight = 0.066 kg/piece

APPLICATIONS

- General constructions, particularly for subsequent insertion of profiles into existing constructions
- Fastening of surface elements, table tops
- Strengthening of profile constructions

ASSEMBLY

- Fasten to profile groove with supplied hardware
- For subsequent mounting on vertical nut, a square nut M8 Z with nut fixation, **part no. 21.1390/2** is preferred
- Recommended locking torque: 20 Nm

MOUNTING ANGLE 45 GD-Z, CONDUCTIVE

Part no.

21.1133/6

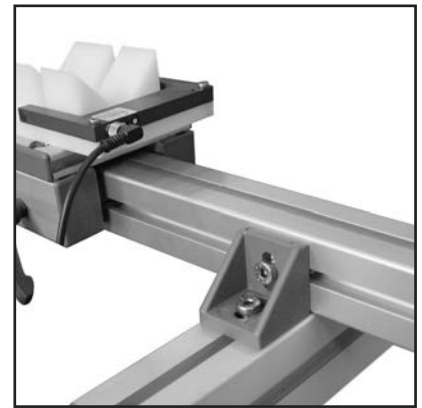
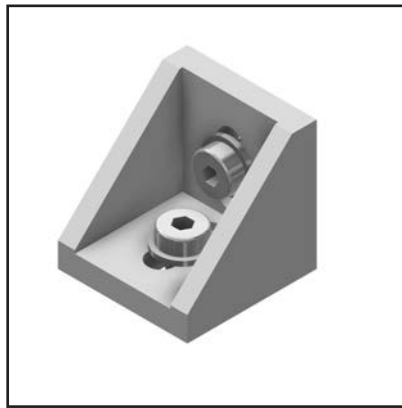
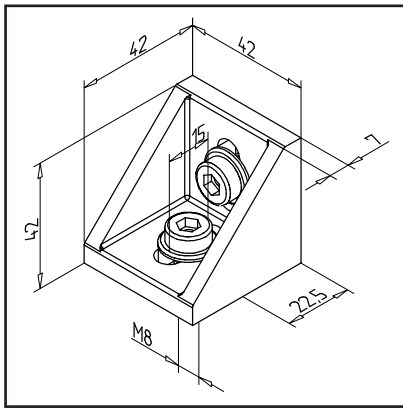
**TECHN. DATA / ITEMS SUPPLIED**

- Aluminium, Pressure die-casting, blasted
- With fastening material steel, zinc plated
- Mounting angle bracket with sliding nut Z with spring panel: **part no. 21.1133/8**
- Weight = 0.101 kg/piece

APPLICATIONS

- General constructions, particularly for subsequent insertion of profiles into existing constructions
- Fastening of surface elements, table tops
- Strengthening of profile constructions

ASSEMBLY

- Fasten to profile groove with supplied hardware
- For subsequent mounting on vertical nut, a square nut M8 Z with nut fixation, **part no. 21.1390/2** is preferred
- Hammer head screw **part no. 21.1370/0** can be used
- Recommended locking torque: 20 Nm

MOUNTING ANGLE 45 X 90 GD-Z, CONDUCTIVE

Part no.

21.1397/6

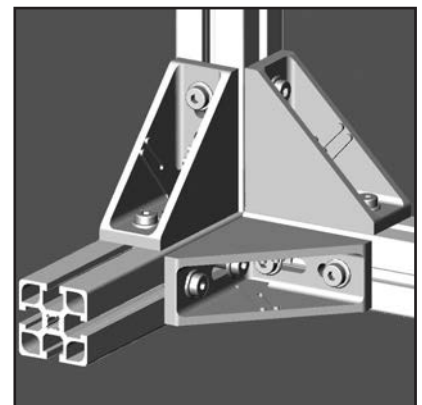
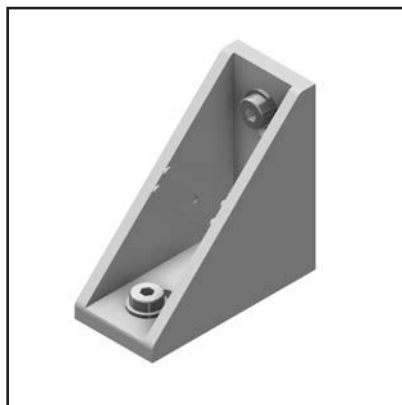
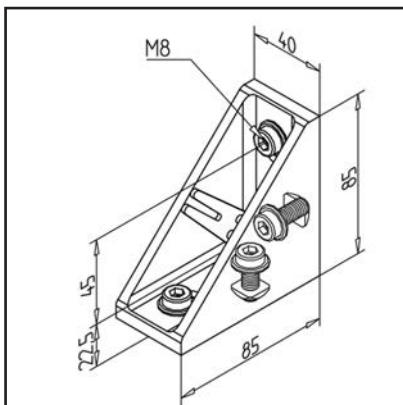
**TECHN. DATA / ITEMS SUPPLIED**

- Aluminium, Pressure die-casting, blasted
- With fastening material steel, zinc plated
- Angle with slide nut Z with spring steel sheet: **part no. 21.1397/8**
- Weight = 0.281 kg/piece

APPLICATIONS

- General constructions, particularly for subsequent insertion of profiles into existing constructions
- Fastening of surface elements, table tops
- Strengthening of profile constructions

ASSEMBLY

- Fasten to profile groove with supplied hardware
- For subsequent mounting on vertical nut, a square nut M8 Z with nut fixation, **part no. 21.1390/2** is preferred
- Recommended locking torque: 20 Nm

MOUNTING ANGLE 30 GD-Z CONDUCTIVE

Part no.

21.0905/6

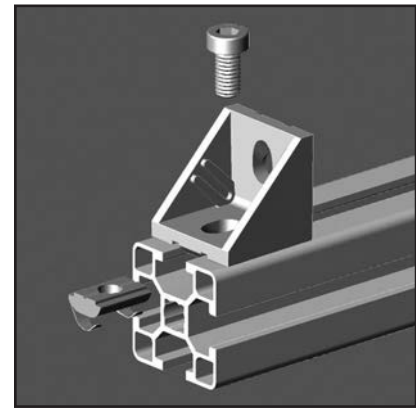
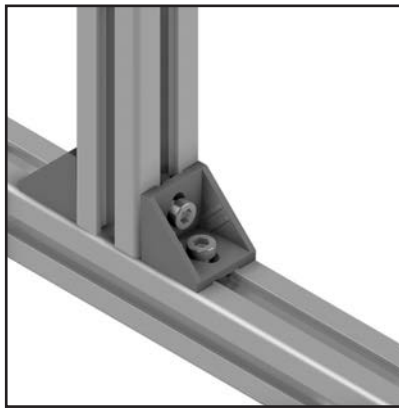
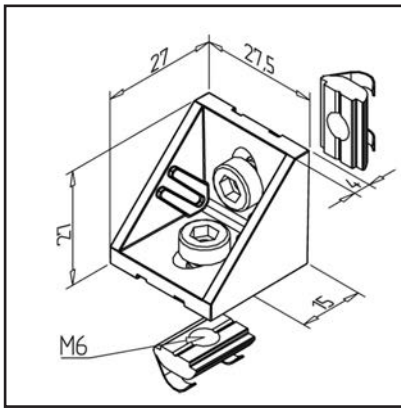

TECHN. DATA / ITEMS SUPPLIED

- Aluminium, Pressure die-casting, blasted
- With fastening material steel, zinc plated
- Removable centering tabs
- Weight = 0.029 kg/piece

APPLICATIONS

- Fastening of surface elements, table tops
- All types of constructions; specifically suited for the subsequent mounting of elements in existing constructions

ASSEMBLY

- Strengthening of profile constructions
- Recommended locking torque: 20 Nm
- For subsequent mounting on vertical nut, a square nut M8 Z with nut fixation, **part no. 21.1390/2** is preferred
- Fasten to the profile with supplied hardware

MOUNTING ANGLE 90 GD-Z CONDUCTIVE

Part no.

21.0978/6

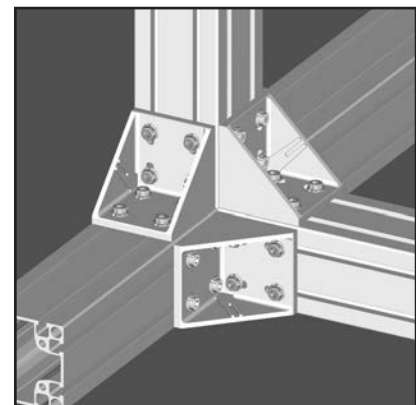
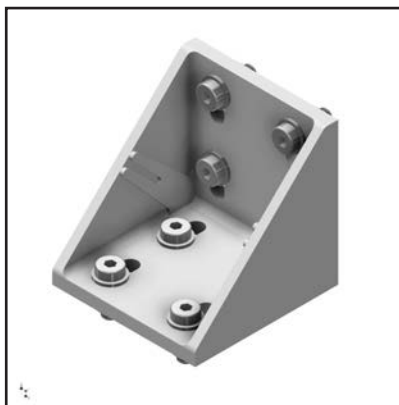
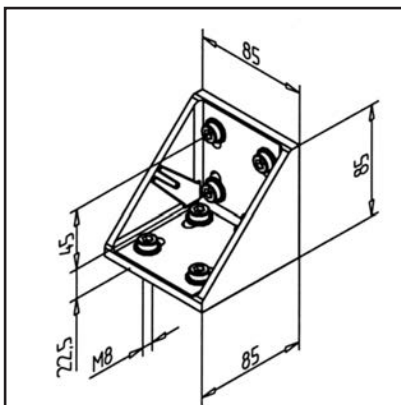

TECHN. DATA / ITEMS SUPPLIED

- Aluminium, Pressure die-casting, blasted
- With fastening material steel, zinc plated
- Locking device against rotation
- Angle with slide nut Z with spring steel sheet: **part no. 21.0978/8**
- Weight = 0.497 kg/piece

APPLICATIONS

- For profiles 90 and 180
- General constructions, particularly for subsequent insertion of profiles into existing constructions
- Fastening of surface elements, table tops
- Strengthening of profile constructions

ASSEMBLY

- Fasten to profile groove with supplied hardware
- For subsequent mounting on vertical nut, a square nut M8 Z with nut fixation, **part no. 21.1390/2** is preferred
- Recommended locking torque: 20 Nm

FOOT D45 CONDUCTIVE

Part no.

32.1011/0

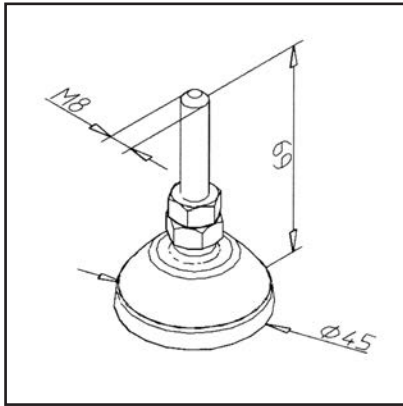
**TECHN. DATA / ITEMS SUPPLIED**

- Plate PA, black
- Anti-slip insert
- Spindle steel, galvanized M8
- Counter nut, steel, zinc plated
- All spindles fit all plates
- Conductive
- Hinged foot ESD D=45 m with spindle M10
part no. 32.1012/0
- Weight = 0.062 kg/piece

**APPLICATIONS**

- Height adjustable heavy constructions of all types
- Guards, tables, show cases, Conveying systems, workstations
- Height adjustable constructions of all kinds
- Protective equipment, tables, showcases
- Conveyors, system workstations

**ASSEMBLY**

- Directly in the central bore of the profile (can be drilled with thread up to M12)
- Larger threads in connection with connection plate
- Direct in central drilling of the profiles
- For threads larger than M12, the hinged feet must be mounted in conjunction with the connection plate
- For profiles 45 x 90 und 90 x 90 a base and transport plate is required, if the feet are to be positioned centrally.

FOOT D80 CONDUCTIVE

Part no.

32.1021/0

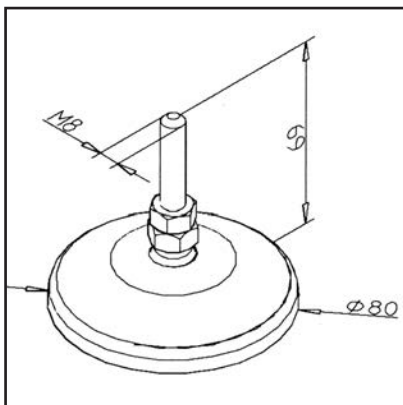
**TECHN. DATA / ITEMS SUPPLIED**

- Plate PA, black
- Anti-slip insert
- Spindle steel, galvanized M8
- Counter nut, steel, zinc plated
- All spindles fit all plates
- Conductive
- Hinged foot ESD D=80 m with spindle M10
part no. 32.1012/0
- Weight = 0.108 kg/piece

**APPLICATIONS**

- Height adjustable heavy constructions of all types
- Guards, tables, show cases, Conveying systems, workstations
- Height adjustable constructions of all kinds
- Protective equipment, tables, showcases
- Conveyors, system workstations

**ASSEMBLY**

- Directly in the central bore of the profile (can be drilled with thread up to M12)
- Larger threads in connection with connection plate
- Direct in central drilling of the profiles
- For threads larger than M12, the hinged feet must be mounted in conjunction with the connection plate
- For profiles 45 x 90 und 90 x 90 a base and transport plate is required, if the feet are to be positioned centrally.

SWIVEL CASTER WITH WHEEL LOCK D75 X 100, CONDUCTIVE

Part no. 32.1030/0

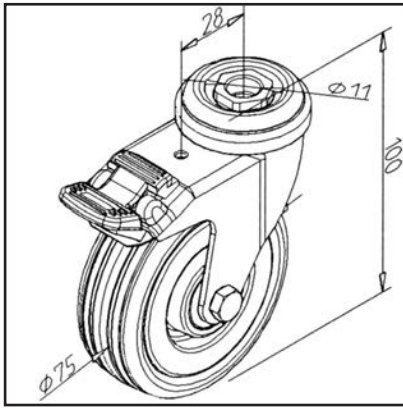

TECHN. DATA / ITEMS SUPPLIED

- With fastening material steel, zinc plated
- Housing steel, galvanized
- Conductive
- Load capacity 50 kg
- **Other versions upon request**
- Weight = 0.322 kg/piece

APPLICATIONS

- Movable tables
- Work stands
- display windows, showcases

ASSEMBLY

- Attach directly to the central bore of the vertical profile with fastening material, then drill and introduce thread M10
- If the roller is to be centrally positioned for profile cross sections greater than 45 x 45, a connection plate is required

SWIVEL CASTER WITHOUT WHEEL LOCK D75 X 100, CONDUCTIVE

Part no. 32.1031/0

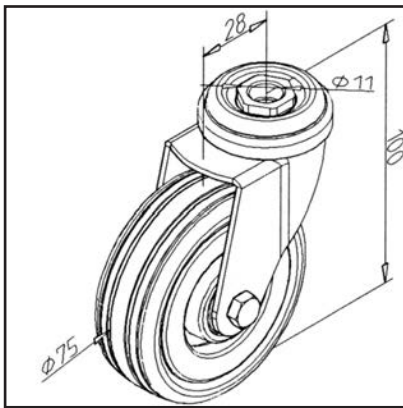

TECHN. DATA / ITEMS SUPPLIED

- With fastening material steel, zinc plated
- Housing steel, galvanized
- Conductive
- Load capacity 50 kg
- **Other versions upon request**
- Weight = 0.292 kg/piece

APPLICATIONS

- Movable tables
- Work stands
- display windows, showcases

ASSEMBLY

- Attach directly to the central bore of the vertical profile with fastening material, then drill and introduce thread M10
- If the roller is to be centrally positioned for profile cross sections greater than 45 x 45, a connection plate is required

SWIVEL CASTOR WITH BRAKE D100 X 135, ESD

Part no.

32.1034/0

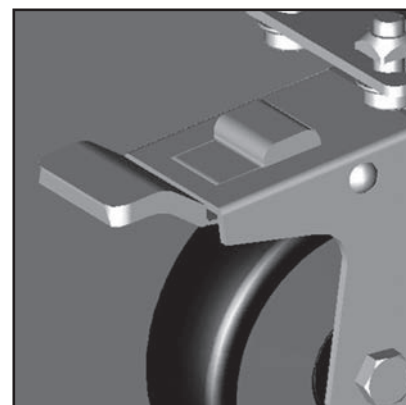
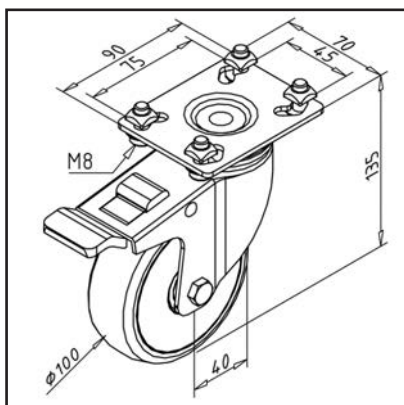
**TECHN. DATA / ITEMS SUPPLIED**

- With fastening material steel, zinc plated
- Housing steel, galvanized
- Conductive
- Load capacity 90 kg
- Weight = 0.881 kg/piece

APPLICATIONS

- Movable tables
- Work stands
- display windows, showcases

ASSEMBLY

- Fasten mounting plate in the profile groove with supplied hardware

SWIVEL CASTOR WITHOUT BRAKE D100 X 135, ESD

Part no.

32.1035/0

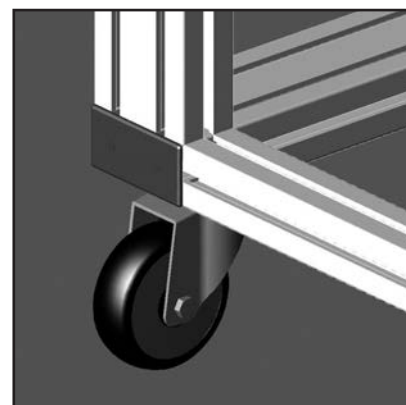
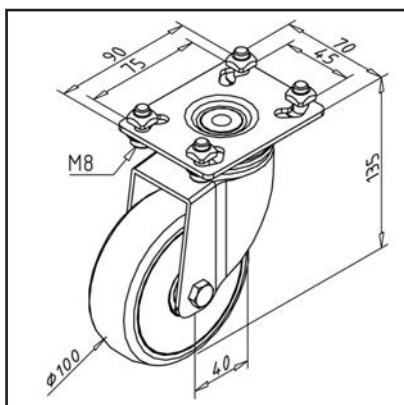
**TECHN. DATA / ITEMS SUPPLIED**

- With fastening material steel, zinc plated
- Housing steel, galvanized
- Conductive
- Load capacity 90 kg
- Weight = 0.765 kg/piece

APPLICATIONS

- Movable tables
- Work stands
- display windows, showcases

ASSEMBLY

- Fasten mounting plate in the profile groove with supplied hardware

FIXED CASTOR D100 X 135, ESD

Part no.

32.1036/0

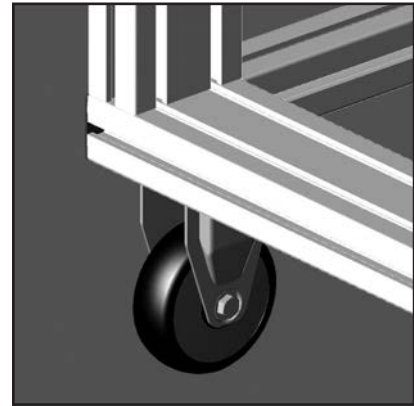
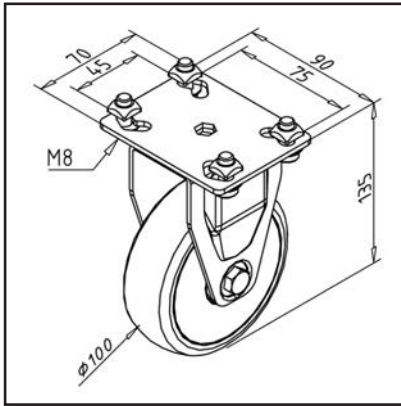

TECHN. DATA / ITEMS SUPPLIED

- With fastening material steel, zinc plated
- Housing steel, galvanized
- Conductive
- Load capacity 90 kg
- Weight = 0.695 kg/piece

APPLICATIONS

- Movable tables
- Work stands
- display windows, showcases

ASSEMBLY

- Fasten mounting plate in the profile groove with supplied hardware

CONNECTION PLATE 45X90 M10 CONDUCTIVE

Part no.

21.1038/6

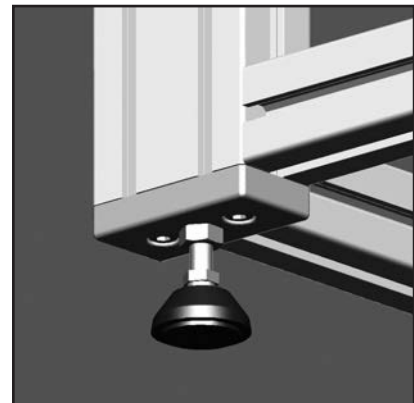
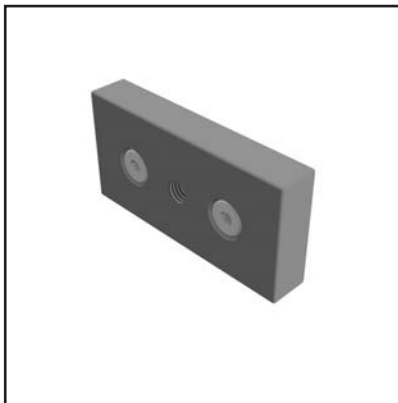
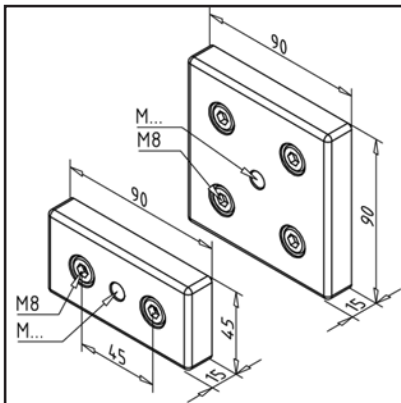

TECHN. DATA / ITEMS SUPPLIED

- Aluminium, Pressure die-casting, blasted
- With fastening material steel, zinc plated
- Fastening kit
- Weight = 0.172 kg/piece

APPLICATIONS

- Central fixation of support feet on profiles 45 x 90 or 90 x 90
- Fixation of guide rollers
- Centric attachment of hinged feet to profiles 45 x 90

ASSEMBLY

- Fasten to the profile with supplied hardware
- Fasten to profile with fastening material from the scope of delivery



4.1

BELT CONVEYORS

474



4.2

ROLLER CONVEYOR

483



4.3

TIMING BELT CONVEYOR

488



4.4

COMPONENTS

491



4.5

TRANSFER SYSTEM TSG

517



4.6

SEGMENTED CHAIN CONVEYOR GKF

534

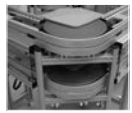

4.7

FLEXIBLE ASSEMBLY LINES FMS

538



4.8

ROLLER CONVEYORS RMS

540



4.9

PALLET CIRCULATION SYSTEM UMS

542

BELT CONVEYORS

EXAMPLES



BELT CONVEYORS

SERIES 45

The conveyor belt module in our MiniTec iCADassembler design software automatically designs your conveyor belt according to your specifications, calculates the deflection, suggests the number of supports and generates the parts list. Within a few minutes. Assembly is just as quick and easy thanks to our tried-and-tested components.

ENGINE ARRANGEMENT

Plug-on

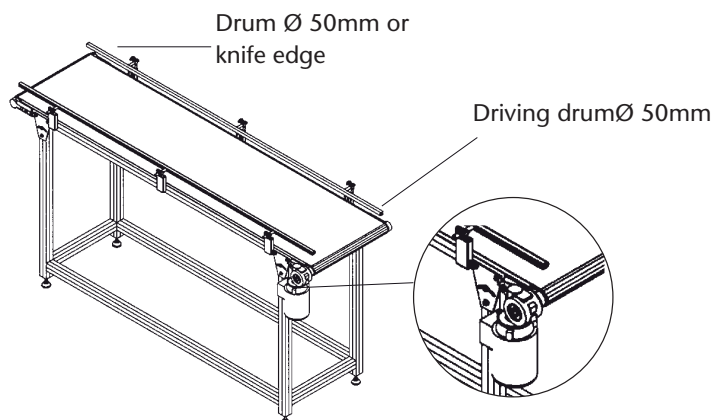

Flange motor with cover

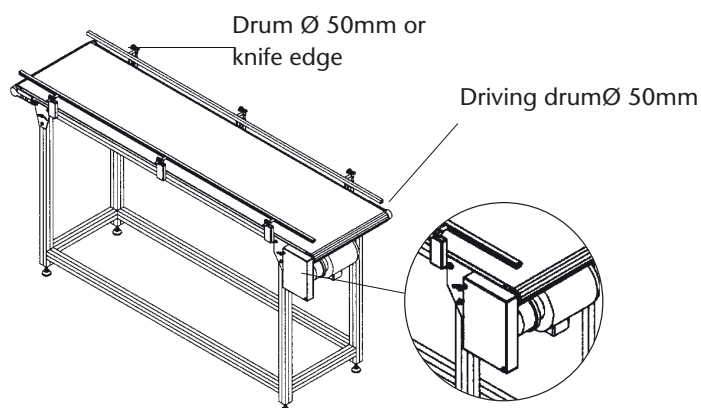

Center drive (direct drive)

- Belt width max. 300 mm at knife edge
- Belt width max. 800 mm with drum Ø 50

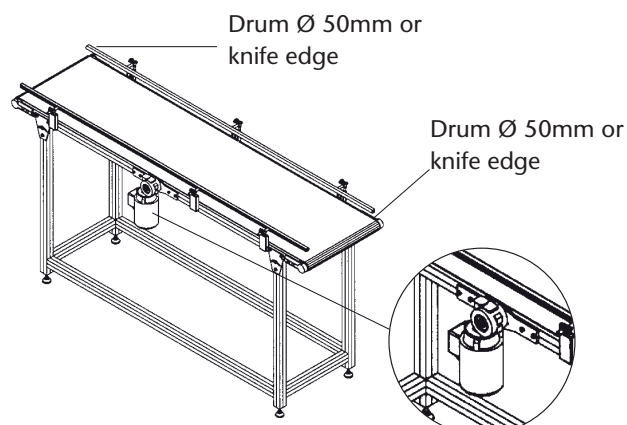

BELT CONVEYORS

SERIES 45

Center drive (direct drive)

- Belt width max. 800 mm

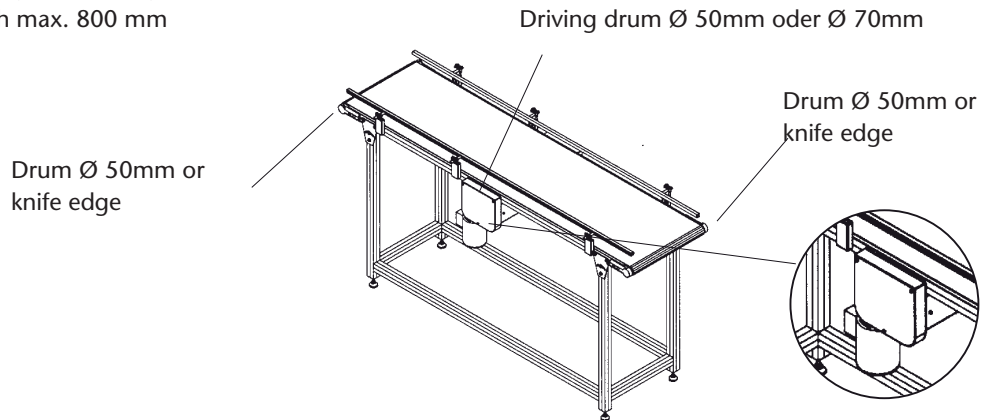

Drum motor

- Belt width min. 260 mm
- Belt width max. 500 mm
- max. length 2000 mm
- max. 20 kg total load

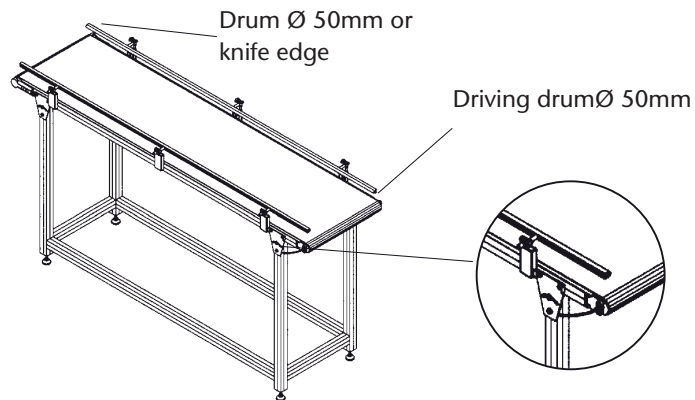

Subconstruction

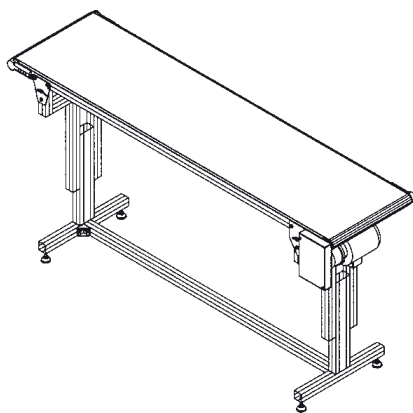

Height adjustable

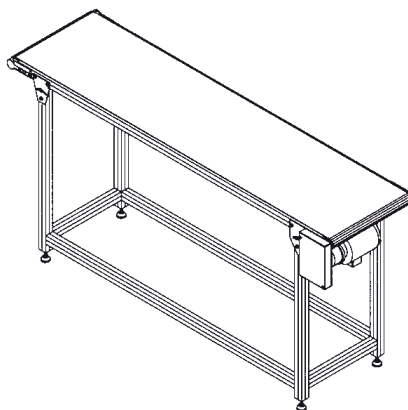

Standard

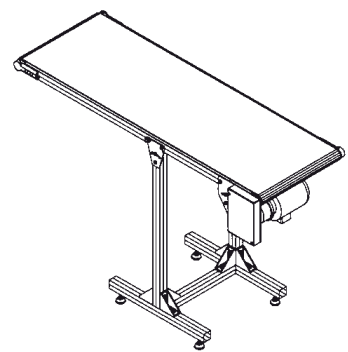

with stand

BELT CONVEYORS

REQUEST STANDARD CONVEYOR BELT 45

Basic dimensions

Center distance A	mm
Belt width L	mm
Operating conditions	
Conveyed	
Units weight	kg
Total load on tape	kg
Temperature conveyed	°C

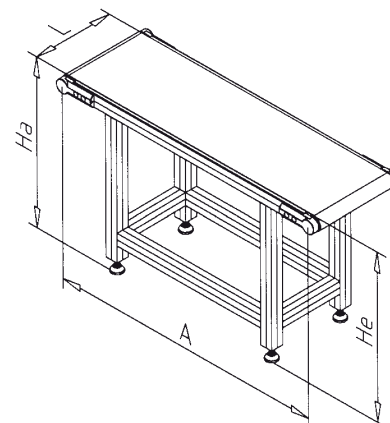

Subconstruction

Inlet height He	mm
Discharge height Ha	mm
Number of pillars	Pcs.
Pillars height adjustable from	mm to mm
Lateral guiding	one-sided both-sided short long
Floor assembly angel	Part no. 21.1112/0
High performance anchor 12	Part no. 21.1115/0
Roll	Part no.
Stand	Part no.

Options

Belt	Part no.	<input type="text"/>
Intermediate plate	Aluminium	Inox

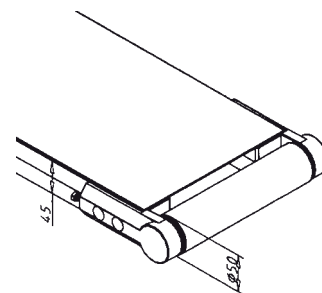

Drive

Engine location	Plug-on	Flange
	Drum motor	Center drive (direct drive)
		Center drive 3-roller system
Speed		m/min.
Speed adjustable from	m/min. to	m/min.

Contact details

Company	Please call me back
Contact	I ask for a written offer
Phone number	
Fax number	
E-Mail	

BELT CONVEYORS

INQUIRY KNIFE EDGE TAPE

Basic dimensions

Center distance A	<input type="text"/>	mm
Belt width L	<input type="text"/>	mm (max.300mm)
Operating conditions		
Conveyed	<input type="text"/>	
Units weight	<input type="text"/>	kg
Total load on tape	<input type="text"/>	kg
Temperature conveyed	<input type="text"/>	°C

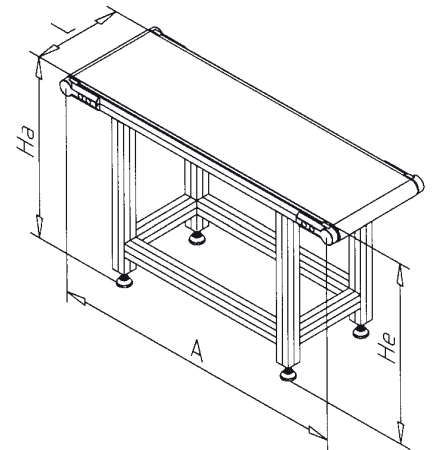
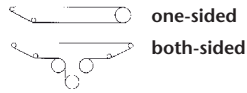

Subconstruction

Inlet height He	<input type="text"/>	mm
Discharge height Ha	<input type="text"/>	mm
Number of pillars	<input type="text"/>	Pcs.
Pillars height adjustable from	<input type="text"/>	mm <input type="text"/>
Lateral guiding	<input type="checkbox"/> one-sided <input type="checkbox"/> both-sided <input type="checkbox"/> short <input type="checkbox"/> long	mm
Floor assembly angel	<input type="checkbox"/> Part no. 21.1112/0	
High performance anchor 12	<input type="checkbox"/> Part no. 21.1115/0	
Roll	<input type="checkbox"/> Part no.	
Stand	<input type="checkbox"/> Part no. <input type="text"/>	

Options

Belt	<input type="checkbox"/> Part no. <input type="text"/>
Intermediate plate	<input type="checkbox"/> Aluminium <input type="checkbox"/> Inox

Drive

Engine location	<input type="checkbox"/> Plug-on	<input type="checkbox"/> Flange
	<input type="checkbox"/> Drum motor	<input type="checkbox"/> Center drive (direct drive)
		<input type="checkbox"/> Center drive 3-roller system

Speed	<input type="text"/>	m/min.
Speed adjustable from	<input type="text"/>	m/min. <input type="text"/>

Contact details

Company	<input type="text"/>	<input type="checkbox"/> Please call me back
Contact	<input type="text"/>	<input type="checkbox"/> I ask for a written offer
Phone number	<input type="text"/>	
Fax number	<input type="text"/>	
E-Mail	<input type="text"/>	

BELT CONVEYORS

CONVEYOR BELT - SERIES 90

The conveyor belt module in our MiniTec iCADassembler design software automatically designs your conveyor belt according to your specifications, calculates the deflection, suggests the number of supports and generates the parts list. Within a few minutes. Assembly is just as quick and easy thanks to our tried-and-tested components.

ENGINE ARRANGEMENT

Plug-on

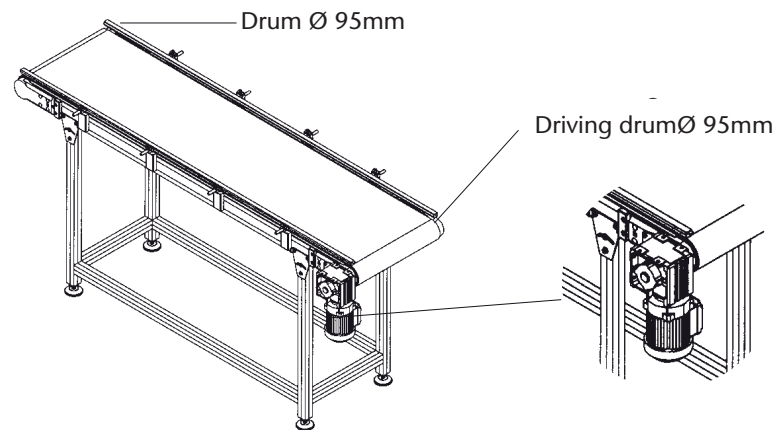

Flange

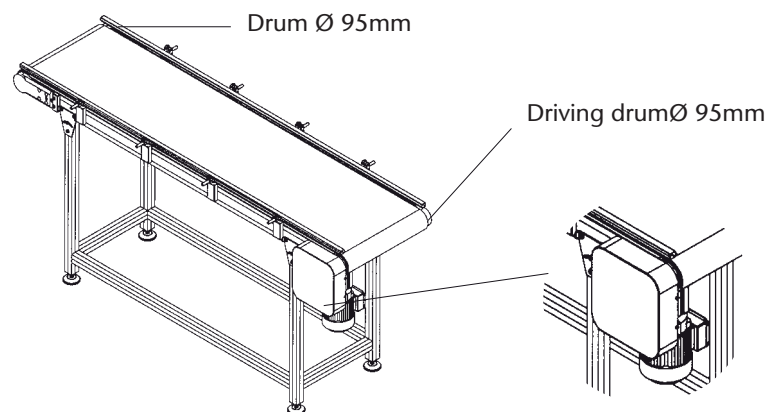

Subconstruction

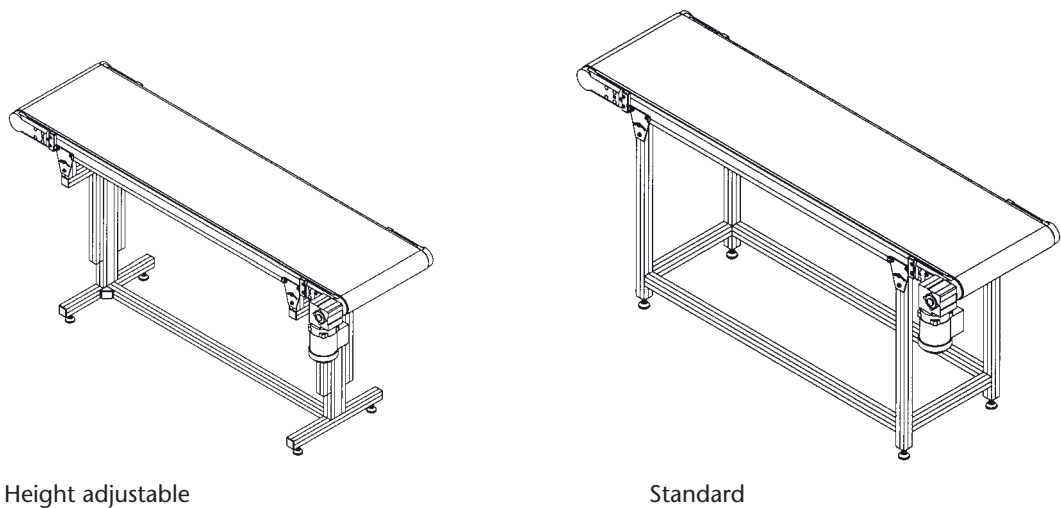

BELT CONVEYORS

INQUIRY STANDARD CONVEYOR BELT 90

Basic dimensions

Center distance A mm

Belt width L mm

Operating conditions

Conveyed

Units weight kg

Total load on tape kg

Temperature conveyed °C

Subconstruction

Inlet height He mm

Discharge height Ha mm

Number of pillars Pcs.

Pillars height adjustable from mm to mm

Lateral guiding one-sided both-sided short long

Floor assembly angel Part no. 21.1112/0

High performance anchor 12 Part no. 21.1115/0

Roll Part no.

Stand Part no.

Options

Belt Part no.

Intermediate plate Aluminium Inox

Drive

Engine location Plug-on Flange

Speed m/min.

Speed adjustable from m/min. to m/min.

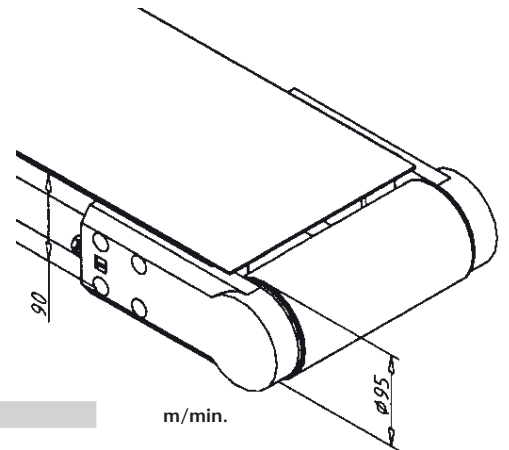
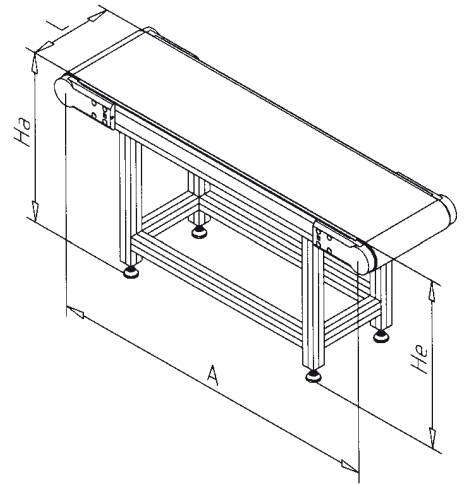

Contact details

Company

Contact

Phone number

Fax number

E-Mail

Please call me back

I ask for a written offer

BELT CONVEYORS

OVERVIEW SIDE GUIDANCE

Conveyor belt 45 and 90

short

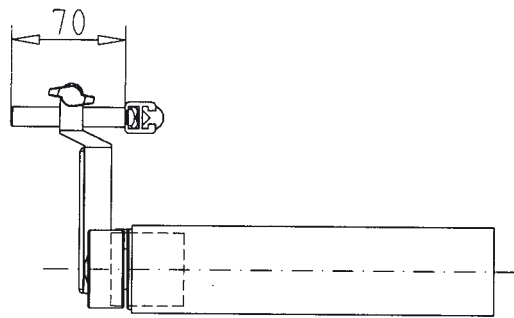

long

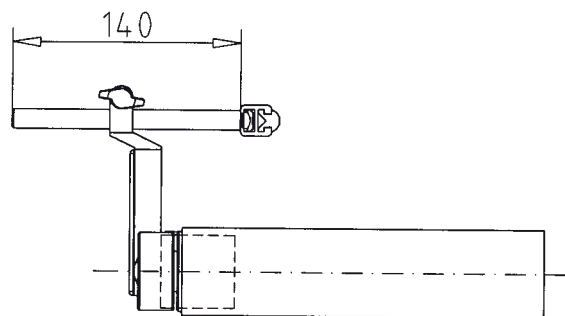

Roller conveyor without drive

LOW



HIGH

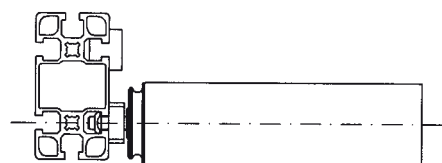

BELT CONVEYORS

CONVEYOR BELTS

CONVEYOR BELT	Part no.
PVC, black, smooth, antistatic	29.5019/1
PVC, green, grip, antistatic	29.5019/2
PVC, green, checkered, adhesive, antistatic	29.5019/3
PVC, green, smooth, antistatic	29.5019/4
PU, blue, smooth	29.5019/5
PU, white, smooth, antistatic	29.5019/6
PVC, white, smooth	29.5019/7
PU, green, smooth, antistatic	29.5019/8
Fabric, white, antistatic	29.5019/9
Special belt on request	29.5019/0
PU, petrol smooth, antistatic	29.5057/0

Calculation of the endless length EL

For drum 45: $EL = 2 \times \text{Axle distance } A + 165 \text{ mm}$

For drum 90: $EL = 2 \times \text{Axle distance } A + 305 \text{ mm}$

EXAMPLES OF SPECIAL BELTS

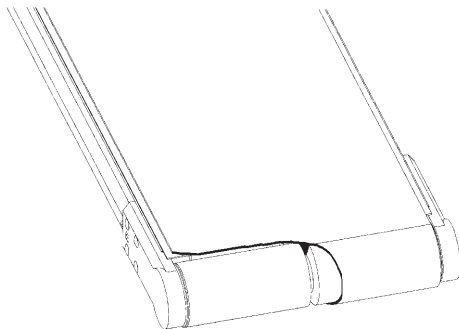

Cuneiform ledge

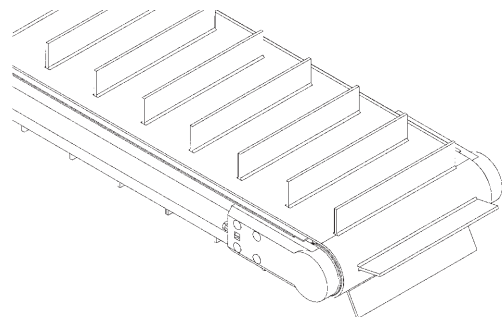

welded cams

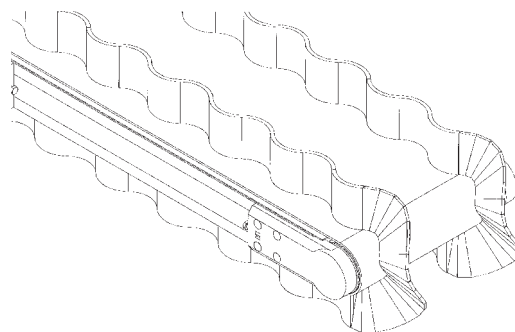

Well edge

ROLLER CONVEYOR

ROLLER TRACK WITHOUT DRIVE

Conveyor roller with bearing

Conveyor rollers S with roller bearings

Carrier profile

45 x 45

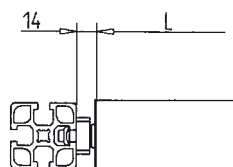
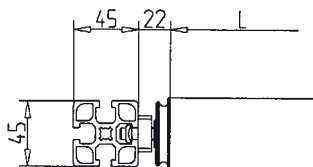

45 x 90

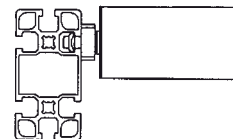
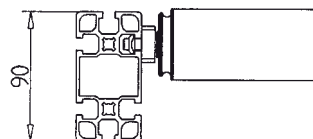

Conveyor rollers

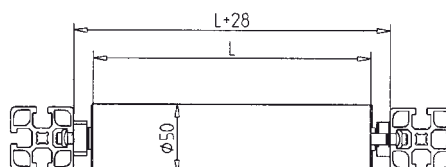
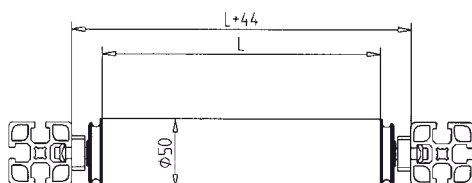

Storage

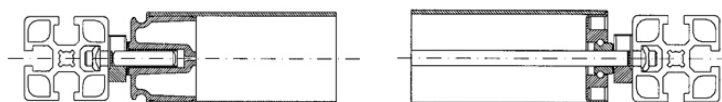

Pipe lengths

max. pipe lengths L	PVC-Pipe	600 mm
	AL-Pipe	1000 mm
	Steel-Pipe	1000 mm

ROLLER CONVEYOR

ROLLER TRACK WITHOUT DRIVE

APPLICATION EXAMPLES



Subconstruction

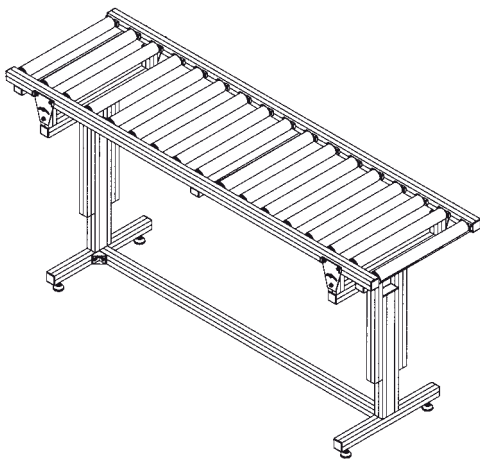

Height adjustable

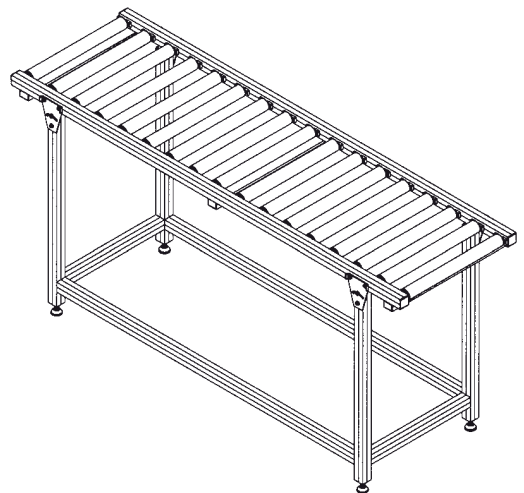

Standard

ROLLER CONVEYOR

INQUIRY ROLLER TRACK WITHOUT DRIVE

Basic dimensions

Center distance A	<input type="text"/>	mm
Roll length L	<input type="text"/>	mm
Division of roles	<input type="text"/>	mm
Carrier profil	45 x 45 45 x 90	

Operating conditions

Conveyed	<input type="text"/>	
Units weight	<input type="text"/>	kg
Total load on tape	<input type="text"/>	kg
Temperature conveyed	<input type="text"/>	°C

Subconstruction

Inlet height He	<input type="text"/>	mm
Discharge height Ha	<input type="text"/>	mm
Distance A	<input type="text"/>	mm
Number of pillars	<input type="text"/>	Pcs.
Pillars height adjustable from	<input type="text"/>	mm to <input type="text"/> mm
Lateral guiding	one-sided both-sided	short long
Lateral guiding 45 x 45	without low	variable

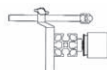

Lateral guiding 45 x 90	without high	variable
-------------------------	-------------------	----------

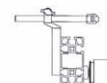

Floor assembly angel	Part no. 21.1112/0
High performance anchor 12	Part no. 21.1115/0
Roll	Part no. <input type="text"/>
Stand	Part no. <input type="text"/>

Options

Roll material	PVC Aluminium Steel
Storage	Bearings Roller bearings

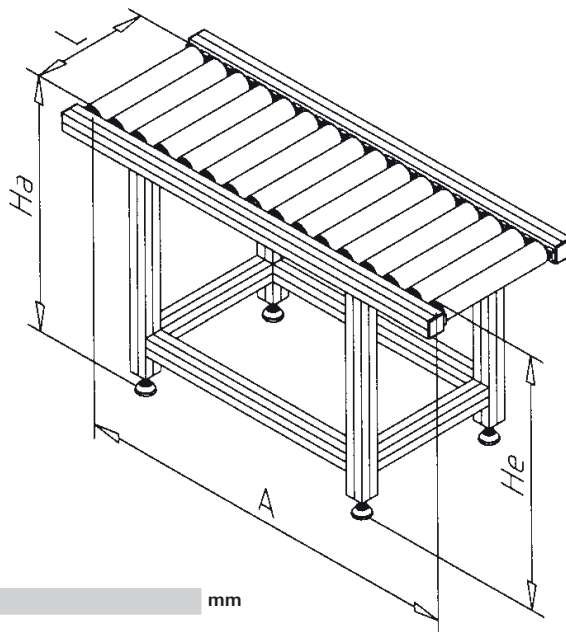

Contact details

Company	<input type="text"/>	■
Contact	<input type="text"/>	
Phone number	<input type="text"/>	
Fax number	<input type="text"/>	
E-Mail	<input type="text"/>	

Please call me back
I ask for a written offer

ROLLER CONVEYOR

ROLLER TRACK WITH DRIVE

ENGINE ARRANGEMENT

Plug-on

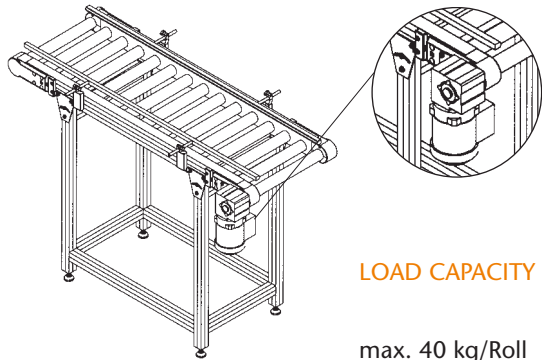

Engine inside

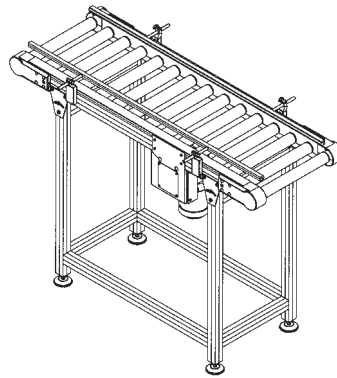

Motor outside, clamping station

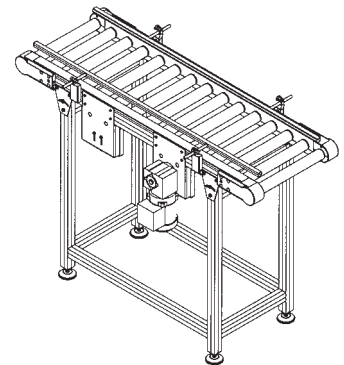

LOAD CAPACITY

max. 40 kg/Roll
max. 300 kg/Drive

Pipe lengths

max. pipe lengths L	PVC-Pipe	600 mm
	AL-Pipe	1000 mm
	Steel Pipe	1000 mm

Roller design

firmly driven
accumulating, accumulation pressure adjustable

Side execution

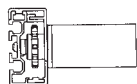

without

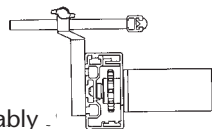

variably

Subconstruction

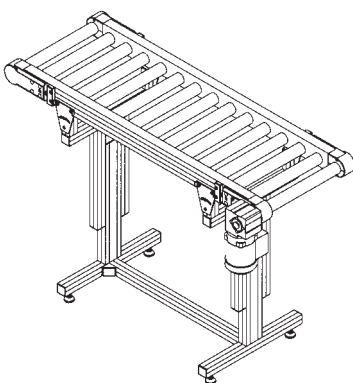

Height adjustable

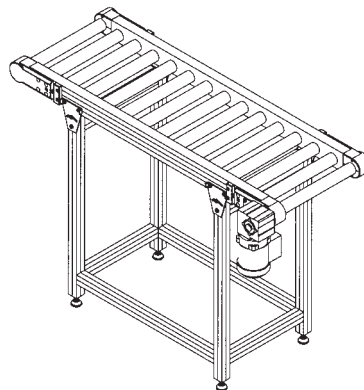

Standard

ROLLER CONVEYOR

Basic dimensions

Center distance A mm
 Conveyor width W mm
 Division of roles mm
 Carrier profil one-sided both-sided

Operating conditions

Conveyed
 Units weight kg
 Total load on tape kg
 Temperature conveyed °C

Subconstruction

Height H mm
 Distance A mm
 Number of pillars Pcs.
 Pillars height adjustable from mm to mm
 Lateral guiding one-sided both-sided
 Floor assembly angel Part no. 21.1112/0
 High performance anchor 12 Part no. 21.1115/0
 Roll Part no.
 Stand Part no.

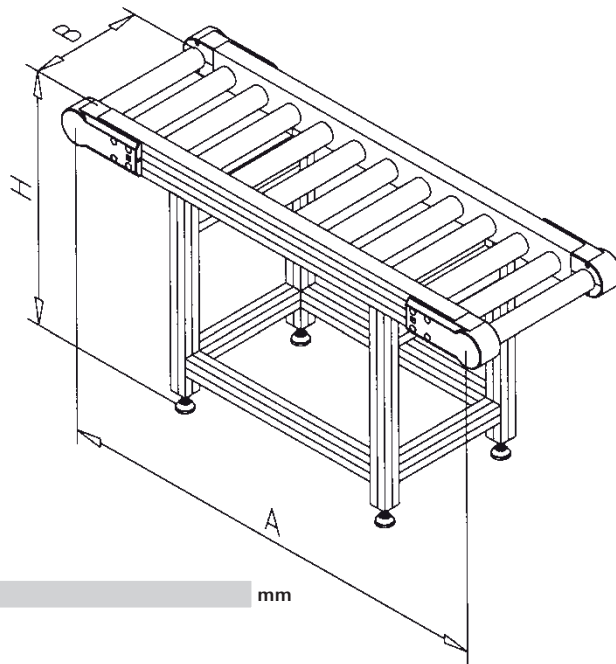

Drive

Engine location Plug-on with clamping station
 inside outside
 Speed m/min.
 Speed adjustable from m/min. to m/min.

Options

Roll material PVC Aluminium Steel
 Accumulating rollers Hard drive

Contact details

Company
 Contact
 Phone number
 Fax number
 E-Mail
 Please call me back
 I ask for a written offer

TIMING BELT CONVEYOR

TIMING BELT CONVEYOR 32

ENGINE ARRANGEMENT

Plug-on

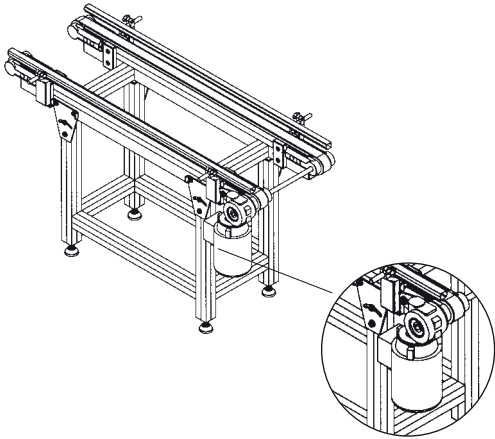

Flange

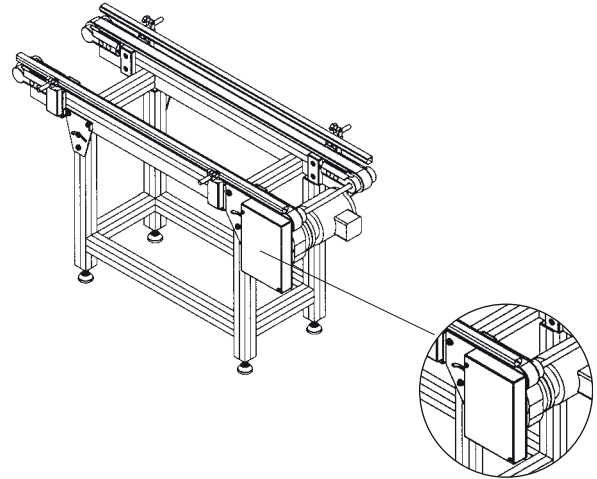

Center drive

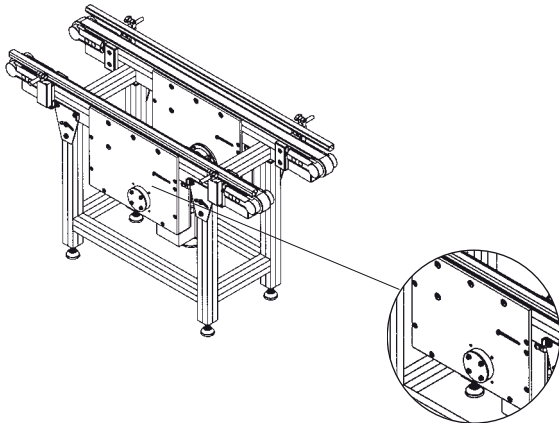

Subconstruction

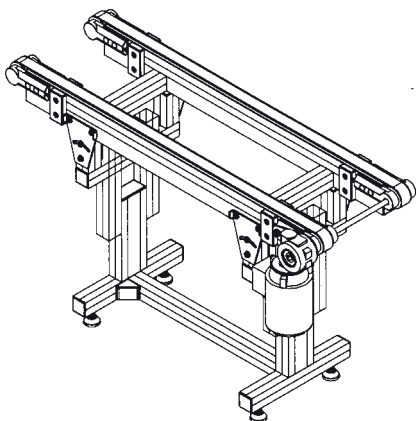

Height adjustable

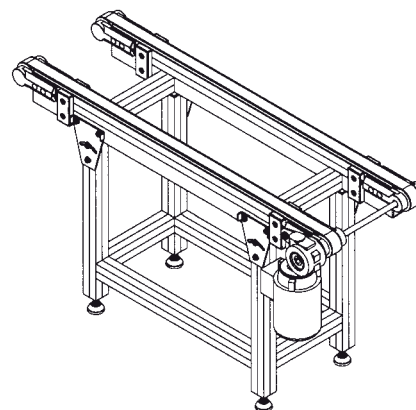

Standard

TIMING BELT CONVEYOR

TIMING BELT CONVEYOR 32

APPLICATION EXAMPLES



Example timing belt conveyor

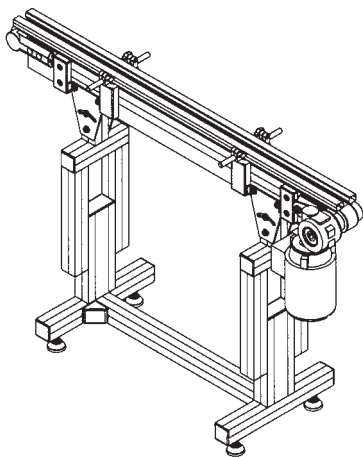

1 lane with variable support

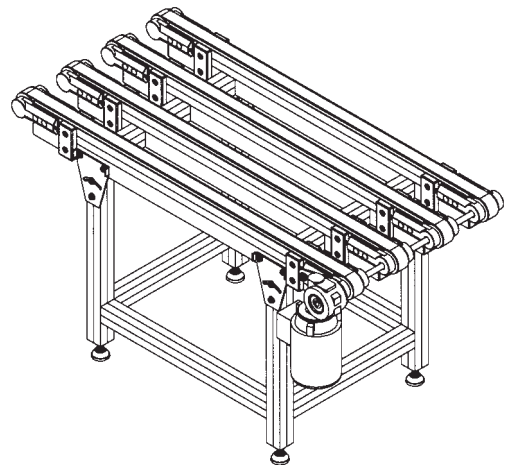

4 lanes with standard support

TIMING BELT CONVEYOR

Basic dimensions

Center distance A mm
 External distance timing belt L mm
 single lane multiple lane

Operating conditions

Conveyed
 Units weight kg
 Total load on tape kg
 Temperature conveyed °C

Subconstruction

Inlet height He mm
 Discharge height Ha mm
 Number of pillars Pcs.
 Pillars height adjustable from mm to mm
 Lateral guiding one-sided both-sided long
 Floor assembly angel Part no. 21.1112/0
 High performance anchor 12 Part no. 21.1115/0
 Roll Part no.
 Stand Part no.

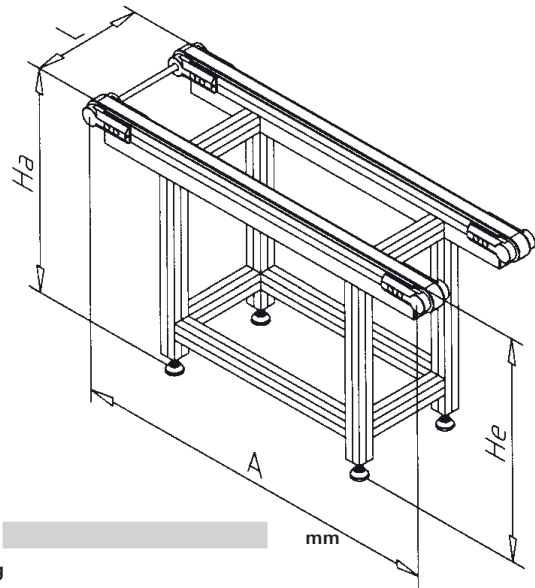

Options

Special coating for timing belts

Drive

Engine location Plug-on Flange
 Center drive
 Speed m/min.
 Speed adjustable from m/min. to m/min.

Contact details

Company
 Contact
 Phone number
 Fax number
 E-Mail

Please call me back
 I ask for a written offer

DRUM BEARING 45

Part no.

21.0993/0

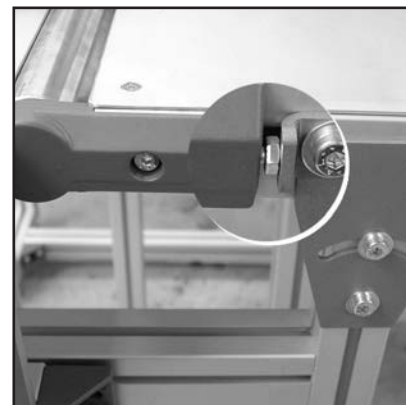
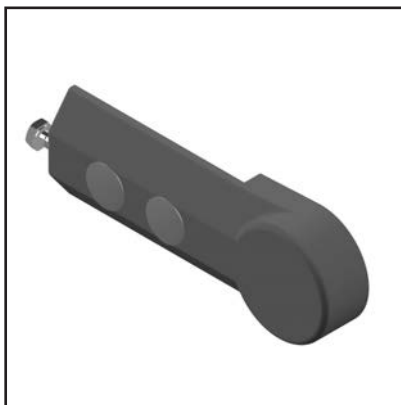
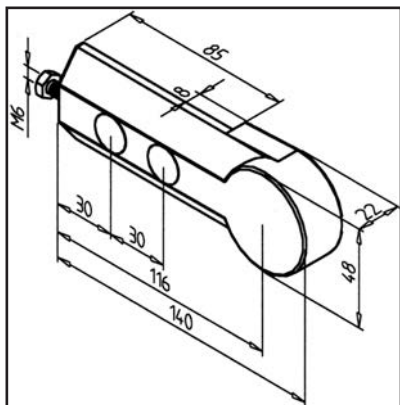
**TECHN. DATA / ITEMS SUPPLIED**

- Aluminium, Pressure die-casting, powder-coated, grey
- Self-aligning bearing with bore \varnothing 17 mm, sealed on both sides
- Version in aluminium GD, with stainless bearing and fastening kit, conveyor bearing 45 H, **part no. 21.0993/5**
- Stainless version, conveyor bearing 45 VA, **part no. 21.0979/0**
- Weight = 0.287 kg/piece

APPLICATIONS

- Reversing unit and driving drums bearing of conveyor belts
- Drum storage 45 with intervention protection **part no. 21.0909/0**
- In the rust-resistant drum bearings the intervention protection can be retrofitted **part no. 21.0909/9**

ASSEMBLY

- Pre-mount drum bearing to profile end
- When using swivel plates **part no. 29.5001/0** for mounting the substructure, these serve as counter-bearings for clamping, otherwise use multi-block or mounting angle bracket
- Tighten the conveyor belt by unscrewing the set screw, if necessary reset the tool
- Firmly tighten the drum bearing (recommended tightening torque: 25 Nm)

DRUM BEARING 45 WITH BORE

Part no.

21.0993/1

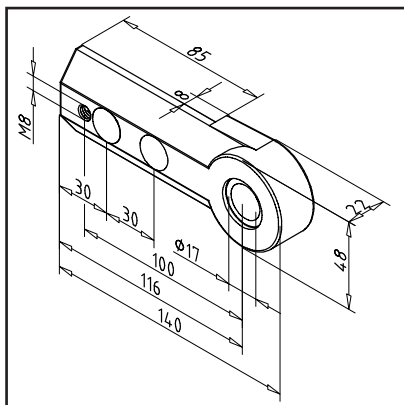
**TECHN. DATA / ITEMS SUPPLIED**

- Aluminium, Pressure die-casting, powder-coated, grey
- With bore for drive adapter
- Self-aligning bearing with bore \varnothing 17 mm, sealed on both sides
- Version in aluminium GD, with stainless bearing and fastening kit, conveyor bearing 45 H, **part no. 21.0993/6**
- Stainless version, conveyor bearing 45 VA with bore, **part no. 21.0980/0**
- Weight = 0.287 kg/piece

APPLICATIONS

- Reversing unit and driving drums bearing of conveyor belts
- Attachment of plug in motors or chain wheels to through shaft up to max. \varnothing 17 mm
- Can be retrofitted with intervention protection **part no. 21.0909/9**

ASSEMBLY

- Pre-mount drum bearing to profile end
- When using swivel plates **part no. 29.5001/0** for mounting the substructure, these serve as counter-bearings for clamping, otherwise use multi-block or mounting angle bracket
- Tighten the conveyor belt by unscrewing the set screw, if necessary reset the tool
- Firmly tighten the drum bearing (recommended tightening torque: 25 Nm)

DRUM BEARING 45 - 20

Part no.

21.0917/0

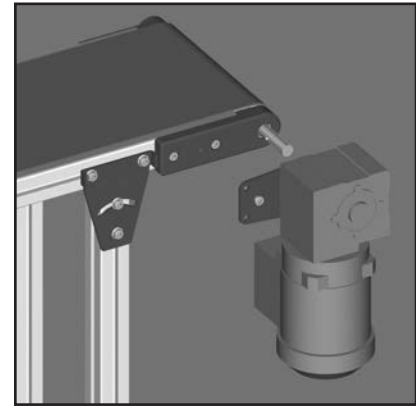
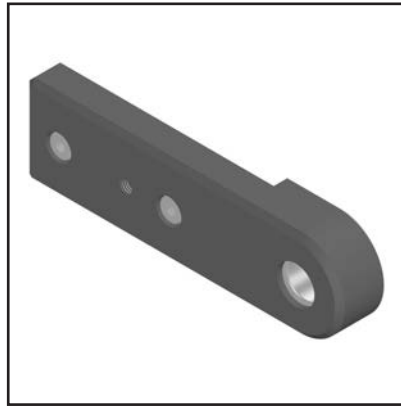
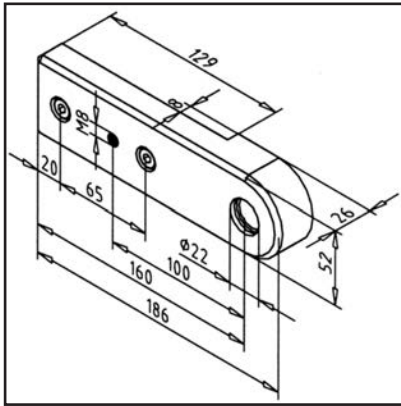

TECHN. DATA / ITEMS SUPPLIED

- Aluminium, powder-coated, grey
- With fastening material steel, zinc plated
- Self-aligning bearing with hole \varnothing 20 mm, sealed on both sides
- Weight = 0.582 kg/piece

APPLICATIONS

- MiniTec conveyor belts for plug-on motors with hollow shaft \varnothing 20 mm in conjunction with torque arms **part no. 29.0536/0** or **29.0537/0** and drum **part no. 29.5042/0**
- Can be retrofitted with intervention protection **part no. 21.0909/9**

ASSEMBLY

- Pre-mount drum bearing to profile end
- Firmly tighten the drum bearing (recommended tightening torque: 25 Nm)

BELT TENSIONING CYLINDER 45 ST

Part no.

21.0994/1

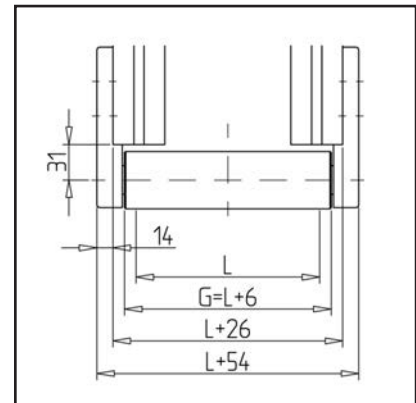
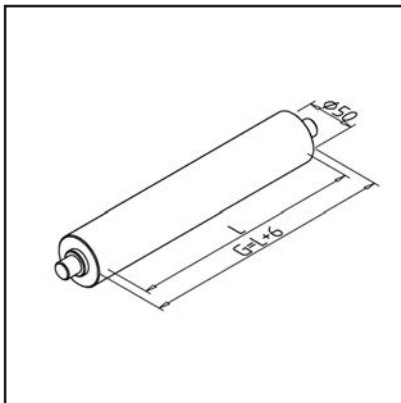

TECHN. DATA / ITEMS SUPPLIED

- Stainless steel
- Turned round
- **Please specify dimension L (belt width)**
- **Attention: L is not the external dimensions(G) of the conveyor \varnothing 50**
- Weight = (basic weight) 0.186 kg
- Extra weight = 1.541 kg/100mm belt width

APPLICATIONS

- MiniTec belt conveyor system
- Suitable for drum storage, e.g. **part no. 21.0993/0**
- On request we can deliver the drum with mounted ball bearings. The bearings are gentle on material, hot pressed. Please additionally following **part no. 21.0901/0** order.

ASSEMBLY

- Insert the axes into the bore of the drum bearing
- The drum is guided axially by the self-aligning bearing
- The self-aligning bearing compensates for small misalignments

DRIVE DRUM 45 ST

Part no.

21.0995/0

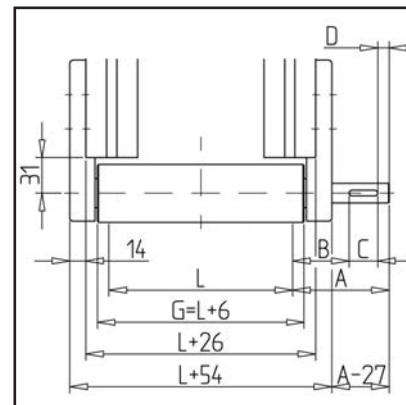
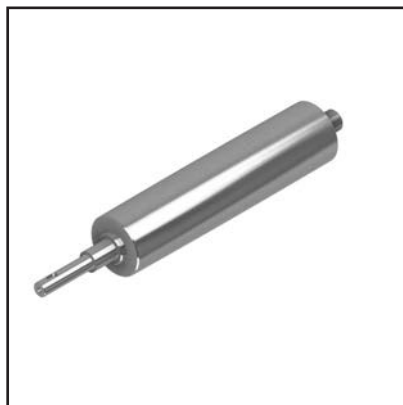
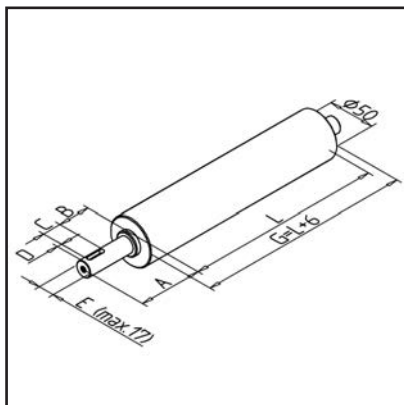
**TECHN. DATA / ITEMS SUPPLIED**

- Stainless steel
- Turned round
- Shaft journal max. \varnothing 17 mm
- **Please indicate belt width as dimensions A, B, C, D and E (if \varnothing 17 mm)**
- **Attention: L is not the external dimensions(G) of the conveyor \varnothing 50**
- Weight = (basic weight) approx. 0.3 kg
- Extra weight = 1.541 kg/100mm belt width

APPLICATIONS

- MiniTec belt conveyor system
- Suitable for drum storage, e.g. **part no. 21.0993/0**
- On request we can deliver the drum with mounted ball bearings. The bearings are gentle on material, hot pressed. Please additionally following **part no. 21.0900/0** order.

ASSEMBLY

- Driving drum in drum bearing with bore e.g. **part no. 21.0993/1** insert
- On the opposite side drum storage e.g. **part no. 21.0993/0** mount
- The drum is sealed between the inner rings of the self-aligning bearing and the drum bearing

DRIVE DRUM 45 ST FOR PLUG-ON MOTOR D16

Part no.

29.5023/1

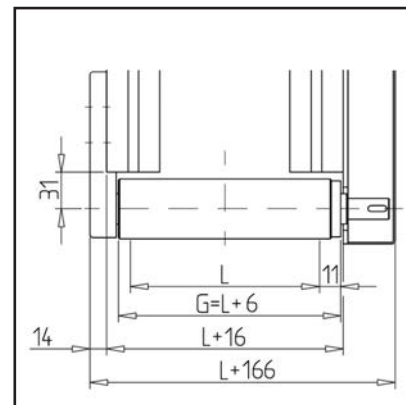
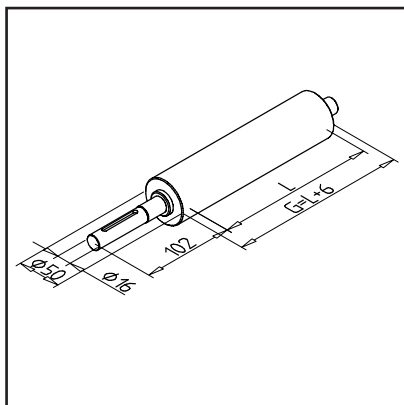
**TECHN. DATA / ITEMS SUPPLIED**

- Stainless steel
- Turned round
- Shaft pin \varnothing 16 mm, drive side machined for mounting of plug-on motor
- **Please specify dimension L (belt width)**
- **Attention: L is not the external dimensions(G) of the conveyor \varnothing 50**
- Weight = (basic weight) approx. 0.3 kg
- Extra weight = 1.541 kg/100mm belt width

APPLICATIONS

- Suitable for MiniTec motor with torque arm of series 45
- On request we can deliver the drum with mounted ball bearings. The bearings are gentle on material, hot pressed. Please additionally following **part no. 21.0900/0** order.

ASSEMBLY

- Drive drum in drum storage for slip-on motor e.g. **part no. 21.0993/1** insert
- On the opposite side drum storage e.g. **part no. 21.0993/0** mount

DRIVE DRUM 45ST FOR PLUG-ON MOTOR D20

Part no. 29.5042/0

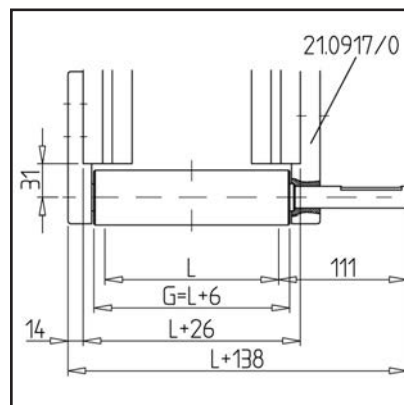
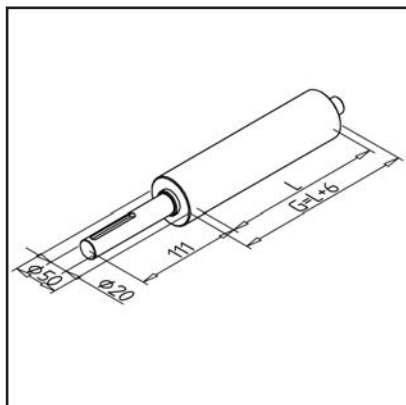

TECHN. DATA / ITEMS SUPPLIED

- Stainless steel
- Turned round
- Shaft journal $\varnothing 20$ mm, drive side machined for installing the chain wheel from kit engine
- **Please specify dimension L (belt width)**
- **Attention: L is not the external dimensions(G) of the conveyor $\varnothing 50$**
- Weight = (basic weight) approx. 0.3 kg
- Extra weight = 1.541 kg/100mm belt width

APPLICATIONS

- MiniTec belt conveyor systems DSGM with torque support Wa 20 and WA 30
- Suitable for MiniTec motor with torque arm of series 90
- On request we can deliver the drum with mounted ball bearings. The bearings are gentle on material, hot pressed. Please additionally following **part no. 21.0900/0** order.

ASSEMBLY

- Insert the belt driving cylinder in the conveyor bearing for plug-on motor 45-20 **Part-N° 21.0917/0**
- On the opposite side drum storage e.g. **part no. 21.0993/0** mount

DRIVE DRUM 45 ST FOR MOTOR ATTACHMENT KIT 45

Part no. 29.5022/0

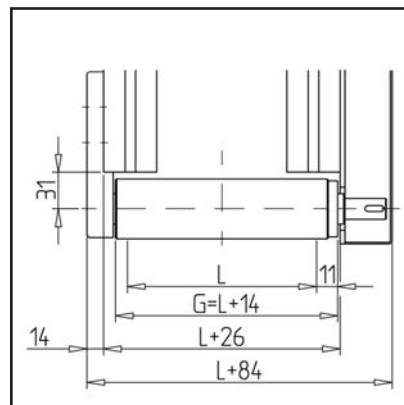
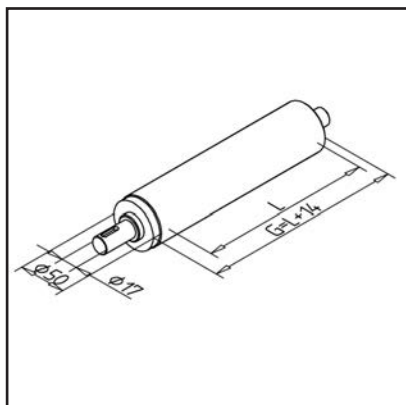

TECHN. DATA / ITEMS SUPPLIED

- Stainless steel
- Turned round
- Shaft journal $\varnothing 17$ mm, drive side machined for installing the chain wheel from kit engine
- **Please specify dimension L (belt width)**
- **Attention: L is not the external dimensions(G) of the conveyor $\varnothing 50$**
- Weight = (basic weight) approx. 0.3 kg
- Extra weight = 1.541 kg/100mm belt width

APPLICATIONS

- Can only be used with the MiniTec belt conveyor kit 45
- On request we can deliver the drum with mounted ball bearings. The bearings are gentle on material, hot pressed. Please additionally following **part no. 21.0900/0** order.

ASSEMBLY

- Insert the belt driving cylinder in the bearing housing on the motor side
- On the opposite side drum storage e.g. **part no. 21.0993/0** mount
- The drum is sealed between the inner rings of the pendulums

MOTOR MOUNTING KIT 45 Ø 20 MM

Part no. 29.5031/0

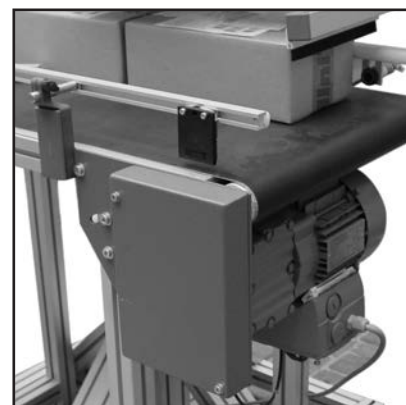
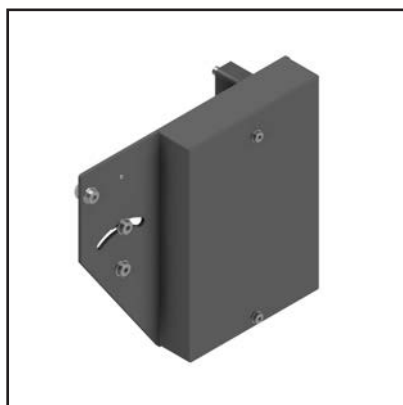
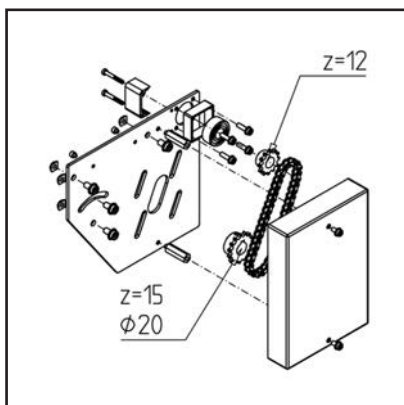
**TECHN. DATA / ITEMS SUPPLIED**

- With fastening material steel, zinc plated
- Motor plate and cover, steel, powder coated, grey
- Bearing housing with self-aligning bearing
- 2 sprockets with drive chain, 1 sprocket drilled for motor shaft diameter $\varnothing 20$ mm
- Weight = 3.266 kg/piece

APPLICATIONS

- Belt-conveyors made of MiniTec aluminium profiles
- Suitable for mounting spur gear motors with flange diameter $\varnothing 120$ mm
- Fitting drive drum **part no. 29.5022/0** and tensioning drum **part no. 21.0994/0**

ASSEMBLY

- Screw the flange plate to the base frame, install the bearing housing with the self-aligning bearing
- Insert drive drum, on the opposite side, eg. drum storage **part no. 21.0993/0** use
- Mount engine, install chain wheels and tighten the chain
- Fit the cover

DRUM BEARING 90

Part no. 21.0985/0

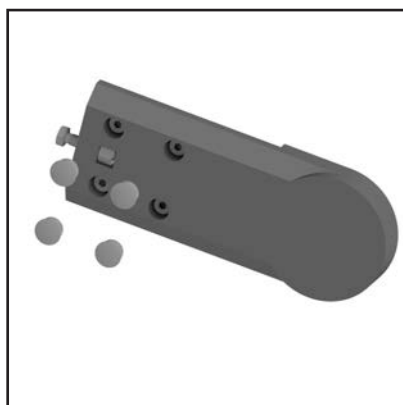
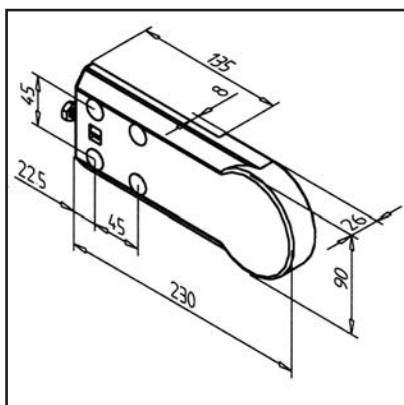
**TECHN. DATA / ITEMS SUPPLIED**

- Aluminium, Pressure die-casting, powder-coated, grey
- Self-aligning bearing with bore $\varnothing 25$ mm, sealed on both sides
- Weight = 0.830 kg/piece

APPLICATIONS

- Reversing unit and driving drums bearing of conveyor belts

ASSEMBLY

- Pre-mount drum bearing to profile end
- As counter bearing for tightening of connection plate 45 x 90
- Tighten the conveyor belt by unscrewing the set screw, if necessary reset the tool
- Firmly tighten the drum bearing (recommended tightening torque: 25 Nm)

DRUM BEARING 90 WITH BORE

Part no. 21.0985/1

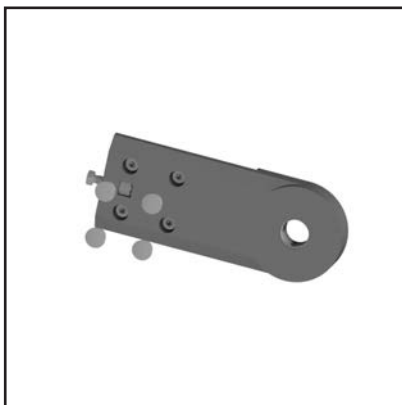
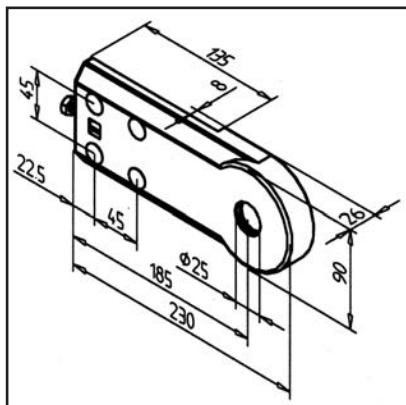

TECHN. DATA / ITEMS SUPPLIED

- Aluminium, Pressure die-casting, powder-coated, grey
- With bore for drive adapter
- Self-aligning bearing with bore \varnothing 25 mm, sealed on both sides
- Weight = 0.830 kg/piece

APPLICATIONS

- Reversing unit and driving drums bearing of conveyor belts
- Attachment of motors or chain wheels, or belt pulleys on shaft; max. \varnothing 25 mm

ASSEMBLY

- Pre-mount drum bearing to profile end
- As counter bearing for tightening of connection plate 32 x 90 or 45 x 90
- Tighten the conveyor belt by unscrewing the set screw, if necessary reset the tool
- Firmly tighten the drum bearing (recommended tightening torque: 25 Nm)

BELT TENSIONING CYLINDER 90

Part no. 21.0982/0

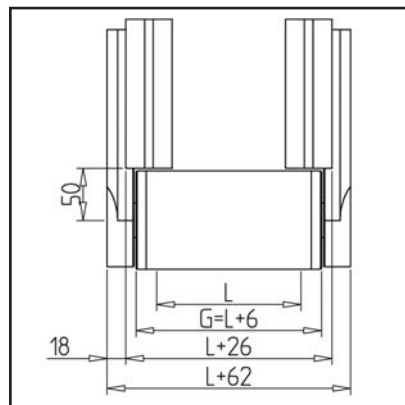
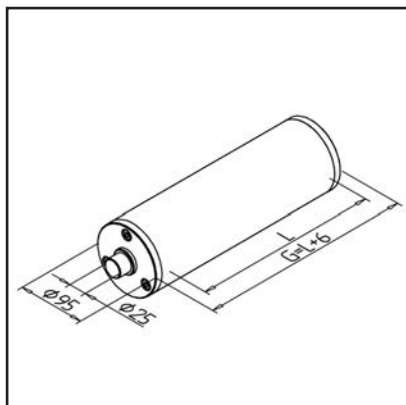

TECHN. DATA / ITEMS SUPPLIED

- Aluminium with shaft made of steel
- Turned round
- Shaft journal \varnothing 25 mm
- **Please specify dimension L (belt width)**
- **Attention: L is not the outer diameter of the conveyor \varnothing 95**
- Weight = (basic weight) 0.465 kg
- Extra weight = 1.506 kg/100 mm belt width

APPLICATIONS

- MiniTec belt conveyor system
- Fitting drum bearing **part no. 21.0985/0**
- Upon request, we can supply the drum with mounted ball bearings. The bearings are hot pressed in a material-friendly manner. In addition, please order the following **part no. 21.0903/0**

ASSEMBLY

- Insert axes in the bore of the self-aligning bearings of the conveyor bearing
- The drum is guided axially by the self-aligning bearing
- The self-aligning bearing compensates for small misalignments

DRIVE DRUM 90

Part no. 21.0981/0

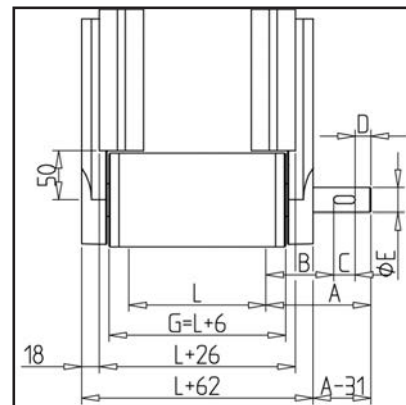
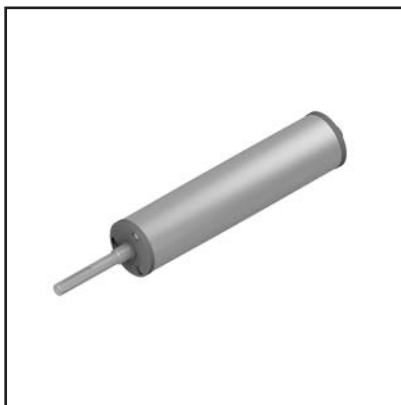
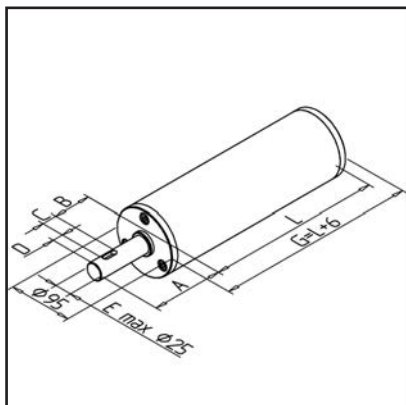
**TECHN. DATA / ITEMS SUPPLIED**

- Aluminium with shaft made of steel
- Turned round
- Shaft journal max. \varnothing 25 mm
- **Please specify dimension L (belt width) as well as dimensions A, B, C, D and E (if $>$ \varnothing 25 mm)**
- **Attention: L is not the outer diameter of the conveyor \varnothing 95**
- Weight = (basic weight) approx. 0.7 kg
- Extra weight = 1.506 kg/100 mm belt width

APPLICATIONS

- MiniTec belt conveyor system
- Use fitting drum bearing **part no. 21.0985/0** and **part no. 21.0985/1**
- Upon request, we can supply the drum with mounted ball bearings. The bearings are hot pressed in a material-friendly manner. In addition, please order the following **part no. 21.0902/0**.

ASSEMBLY

- Insert belt driving cylinder in conveyor bearing with bore **part no. 21.0985/1**
- Mount drum bearing at opposite part **part no. 21.0985/0**
- The drum is sealed between the inner rings of the self-aligning bearing and the drum bearing

DRIVE DRUM 90 FOR ENGINE MOUNTING KIT 90

Part no. 29.5069/0

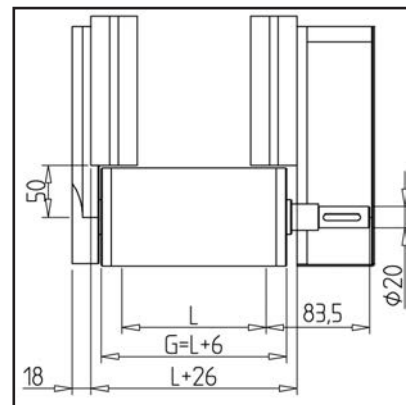
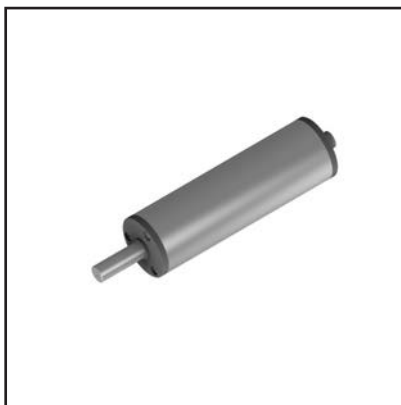
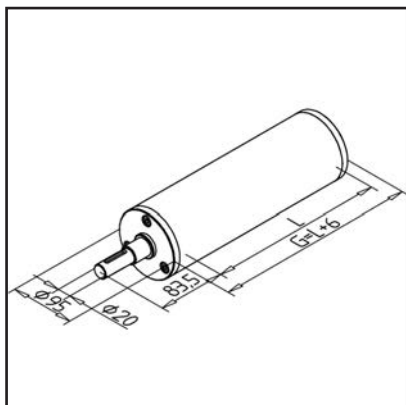
**TECHN. DATA / ITEMS SUPPLIED**

- Aluminium with shaft made of steel
- Turned round
- Shaft journal \varnothing 20 mm
- **Please specify dimension L (belt width)**
- **Attention: L is not the outer diameter of the conveyor \varnothing 95**
- Weight = (basic weight) approx. 0.7 kg
- Extra weight = 1.506 kg/100 mm belt width

APPLICATIONS

- MiniTec belt conveyor system with motor kit 90 **part no. 29.5031/0** and drum bearing **part no. 21.0985/0**
- Upon request, we can supply the drum with mounted ball bearings. The bearings are hot pressed in a material-friendly manner. In addition, please order the following **part no. 21.0902/0**.

ASSEMBLY

- Insert the belt driving cylinder in the bearing housing on the motor side
- Mount drum bearing at opposite part **part no. 21.0985/0**

DRIVE DRUM 90 L FOR PLUG-ON MOTOR D20

Part no.

29.5035/0

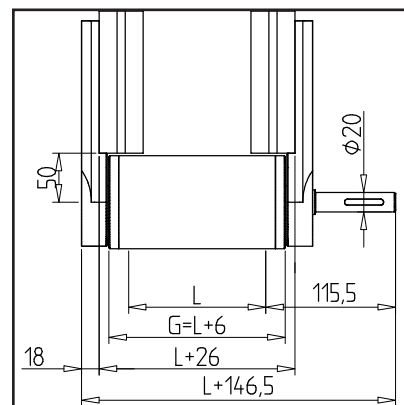
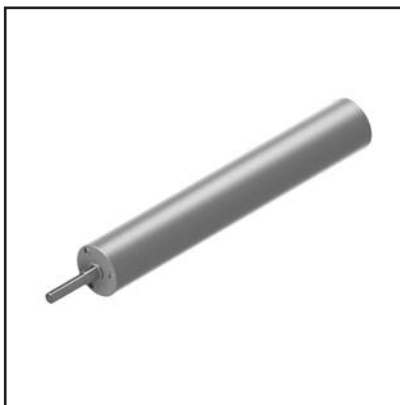
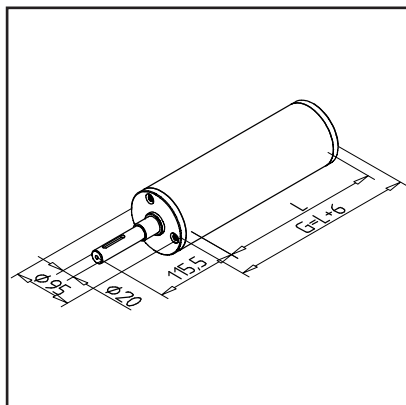

TECHN. DATA / ITEMS SUPPLIED

- Aluminium with shaft made of steel
- Turned round
- Shaft journal $\varnothing 20$ mm
- **Please specify dimension L (belt width)**
- **Attention: L is not the outer diameter of the conveyor $\varnothing 95$**
- Weight = (basic weight) approx. 0.7 kg
- Extra weight = 1.506 kg/100 mm belt width

APPLICATIONS

- MiniTec belt conveyor system with motor kit 90 **part no. 29.5031/0** and drum bearing **part no. 21.0985/0**
- Upon request, we can supply the drum with mounted ball bearings. The bearings are hot pressed in a material-friendly manner. In addition, please order the following **part no. 21.0902/0**.

ASSEMBLY

- Insert the belt driving cylinder in the bearing housing on the motor side
- Mount drum bearing at opposite part **part no. 21.0985/0**

MOTOR MOUNTING KIT 90

Part no.

29.5060/0

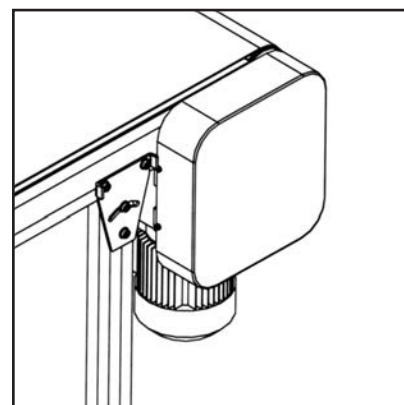
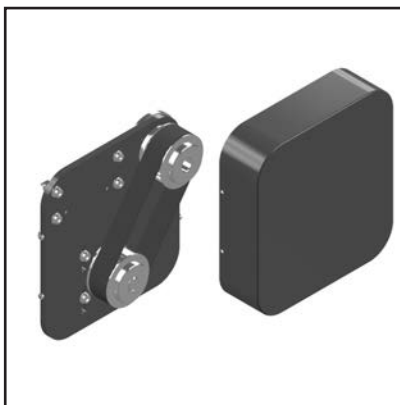
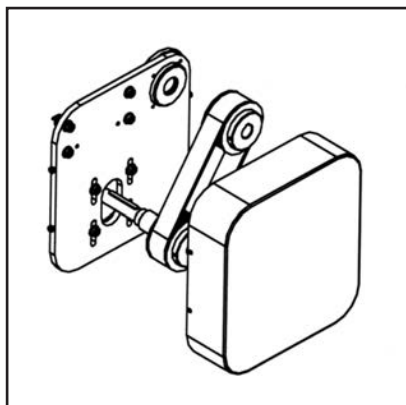

TECHN. DATA / ITEMS SUPPLIED

- Motor plate and cover, steel, powder coated, grey
- Bearing housing with self-aligning bearing
- Belt driving cylinder $\varnothing 20$ mm
- Timing belt 32 AT 10
- Fastening kit
- Weight = 5.973 kg/piece

APPLICATIONS

- Belt-conveyors made of MiniTec aluminium profiles 90
- Suitable for mounting spur gear motors with hollow shaft $\varnothing 20$ mm flange $\varnothing 120$ mm

ASSEMBLY

- Screw the flange plate to the base frame, install the bearing housing with the self-aligning bearing
- Install and tension the motor and timing belt drive
- Insert drive drum, use drum bearing at opposite side **part no. 21.0985/0**
- Fit the cover

TORQUE SUPPORT WA 10

Part no.

29.5040/0

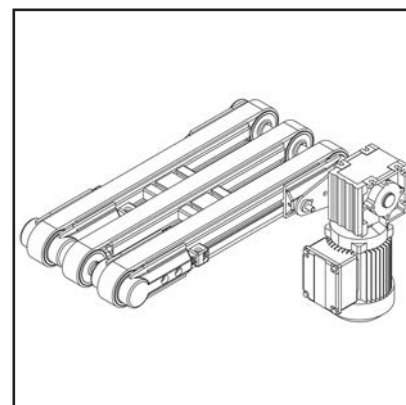
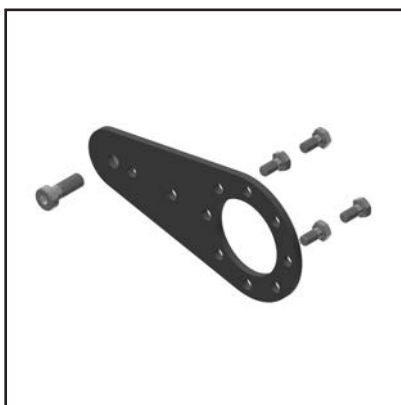
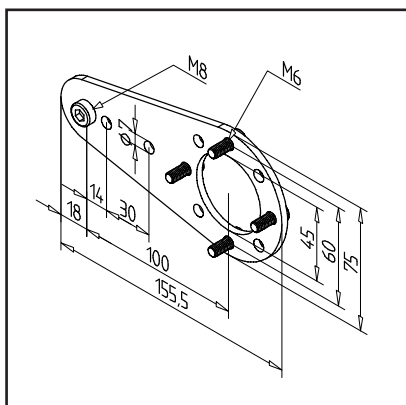

TECHN. DATA / ITEMS SUPPLIED

- Stainless steel, blasted
- with fastening material for Series 45
- Weight = 0.341 kg/piece

APPLICATIONS

- Belt-conveyors made of MiniTec aluminium profiles
- Attachment of plug-on motor DSGM 370 and DSGM 550 for MiniTec belt conveyors 90
- Type 90: Use suitable belt driving cylinder **part no. 29.5035/0** and conveyor bearing **part no. 21.0985/1**
- Type 45: Use suitable belt driving cylinder **part no. 29.5042/0** and conveyor bearing **part no. 21.0917/0**

ASSEMBLY

- Fasten torque support onto motor
- Attach motor on belt driving cylinder
- Fasten torque support
- Type 45: use screw M8 x 20 (not in scope of delivery)

TORQUE SUPPORT WA 20

Part no.

29.5036/0

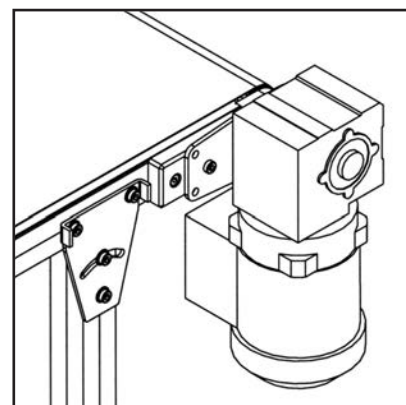
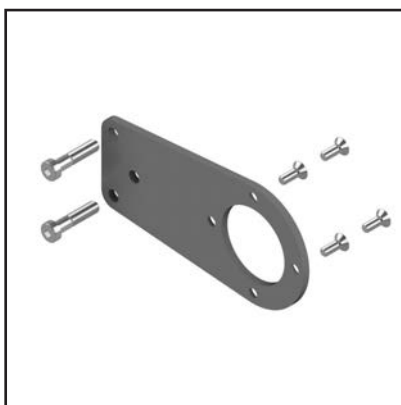
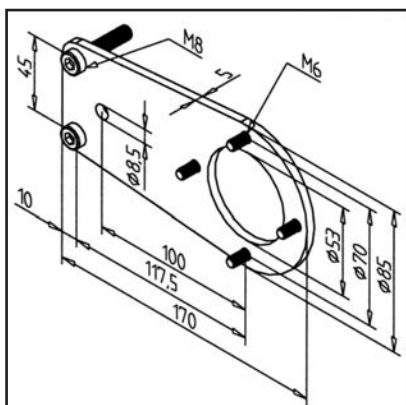

TECHN. DATA / ITEMS SUPPLIED

- Steel, powder-coated, grey
- Fastening kit for type 90
- Weight = 0.430 kg/piece

APPLICATIONS

- Belt-conveyors made of MiniTec aluminium profiles
- Attachment of plug-on motor DSGM 180 and DSGM 250 for MiniTec belt conveyors 45 and 90
- Type 90: Use suitable belt driving cylinder **part no. 29.5035/0** and conveyor bearing **part no. 21.0985/1**
- Type 45: Use suitable belt driving cylinder **part no. 29.5042/0** and conveyor bearing **part no. 21.0917/0**

ASSEMBLY

- Fasten torque support onto motor
- Attach motor on belt driving cylinder
- Fasten torque support
- Type 45: use screw M8 x 20 (not in scope of delivery)

TORQUE SUPPORT WA 30

Part no. 29.5037/0

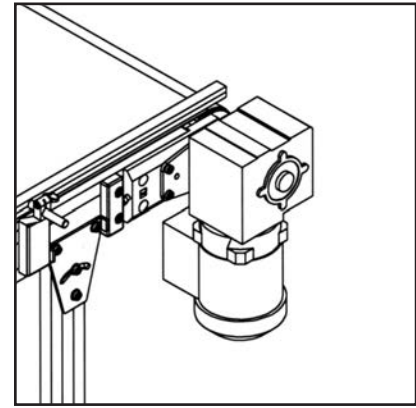
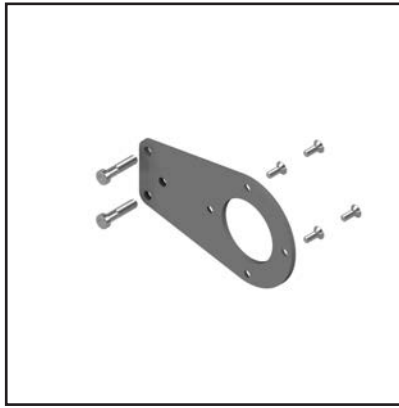
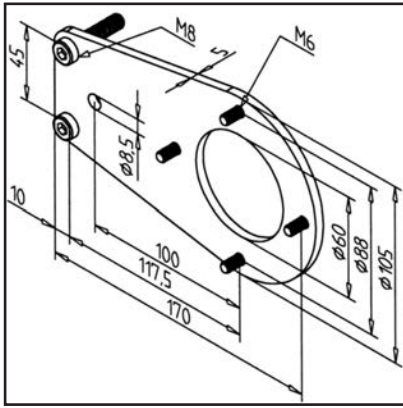

TECHN. DATA / ITEMS SUPPLIED

- Steel, powder-coated, grey
- Fastening kit for type 90
- Weight = 0.514 kg/piece

APPLICATIONS

- Belt-conveyors made of MiniTec aluminium profiles
- Attachment of plug-on motor DSGM 370 and DSGM 550 for MiniTec belt conveyors 90
- Type 90: Use suitable belt driving cylinder **part no. 29.5035/0** and conveyor bearing **part no. 21.0985/1**
- Type 45: Use suitable belt driving cylinder **part no. 29.5042/0** and conveyor bearing **part no. 21.0917/0**

ASSEMBLY

- Fasten torque support onto motor
- Attach motor on belt driving cylinder
- Fasten torque support
- Type 45: use screw M8 x 20 (not in scope of delivery)

KNIFE EDGE 16

Part no. 29.5310/0

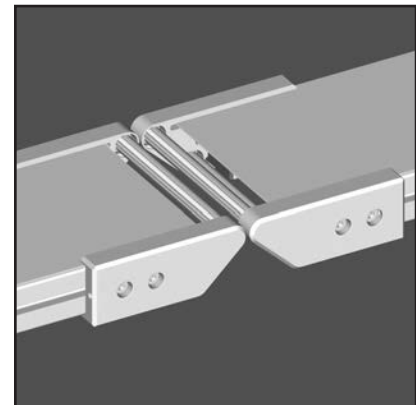
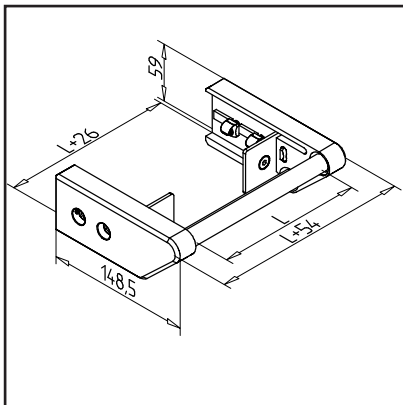

TECHN. DATA / ITEMS SUPPLIED

- Aluminium, natural anodized
- With fastening material steel, zinc plated
- Ball bearing with bore \varnothing 8 mm
- Cylindrical deflection shaft made of steel
- Shaft journal \varnothing 8 mm
- **Please specify belt width L (max 300 mm)**
- Weight = (basic weight) 0.93 kg
- Extra weight = 0.318 kg/100 mm belt width

APPLICATIONS

- For small transport goods and light loads
- Transfer of conveyed goods with the smallest possible gap to the adjacent construction

ASSEMBLY

- Attach to the profile end with supplied hardware
- Align shaft exactly with angle to avoid offset for the bearing

CENTER DRIVE CONVEYOR BELT

Part no.

29.5280/0

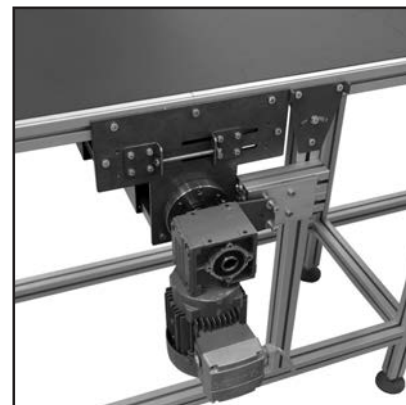
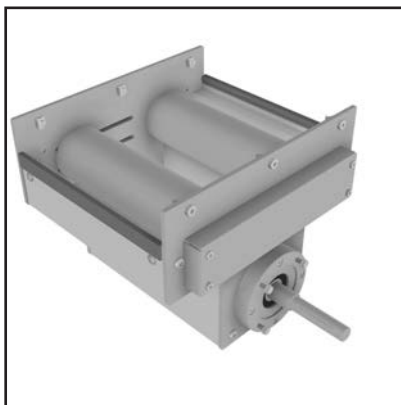
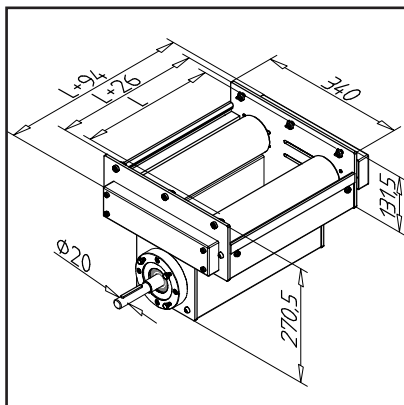

TECHN. DATA / ITEMS SUPPLIED

- 2 tension drums and 1 drive drum
- Ball bearings on both sides
- With complete mounting material, without motor
- Weight = (basic weight) 15.643 kg
- Extra weight = 10.966 kg/100 mm belt width

APPLICATIONS

- Space saving drive
- Motor below conveyor
- Suitable for nosebar on both ends

ASSEMBLY

- Pre-assemble the side plates
- Install drive and tensioning drum with bearing housing
- Install engine, then adjust belt tension and track!
- A selection of suitable motors:
Please refer **Chapter 1.9 Drive & control**

SWIVEL PLATE

Part no.

29.5001/0

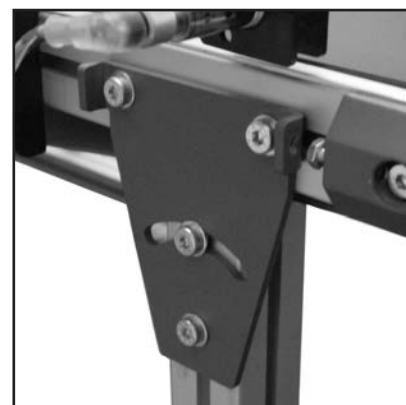
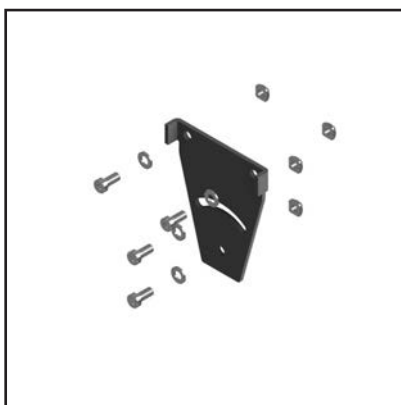
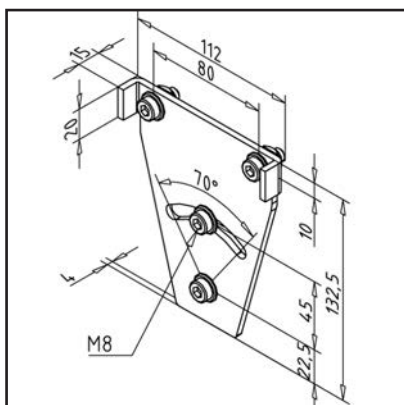

TECHN. DATA / ITEMS SUPPLIED

- Steel, powder-coated, grey
- Stainless version **part no. 29.5012/0**
- Weight = 0.377 kg/piece

APPLICATIONS

- Connection of the substructure to the MiniTec conveyor belt
- Also suitable for inclined conveyor belts
- The swivel plate simultaneously serves as a counter-bearing for tensioning the belt
- Range $\pm 35^\circ$

ASSEMBLY

- Fasten to the side walls of the conveyor belt and to the substructure with supplied hardware

INTERMEDIATE PLATE

Part no. 29.5010/0

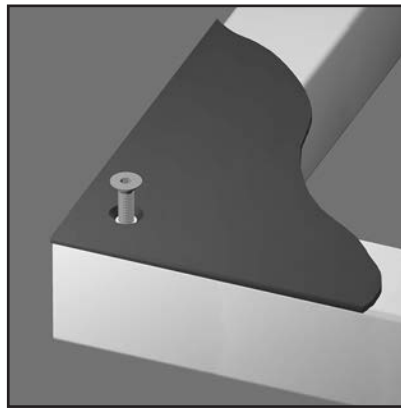
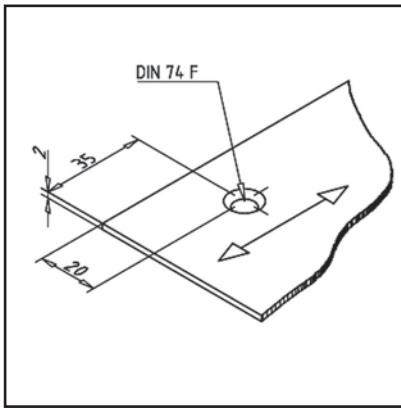

TECHN. DATA / ITEMS SUPPLIED

- Aluminium, anodized E6/EV1
- Thickness: 2 mm
- Drilled ready for installation
- Stainless version **part no. 29.5010/1**

APPLICATIONS

- Sliding support for conveyor belts
- For MiniTec conveyor systems

ASSEMBLY

- Screw onto the profile using countersunk screws M5 x 16 and sliding nut M5

SUPPORT ROLLER CONVEYOR BELT

Part no. 29.5002/0

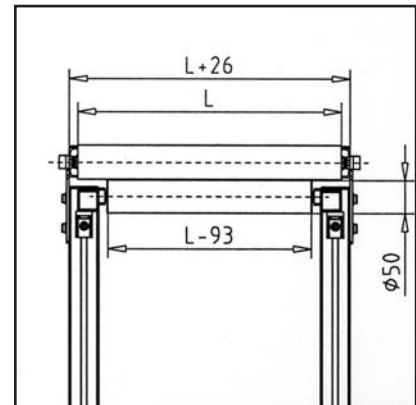
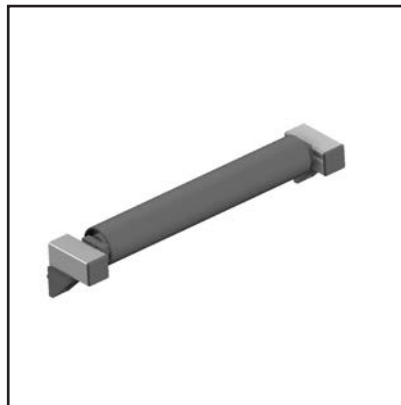
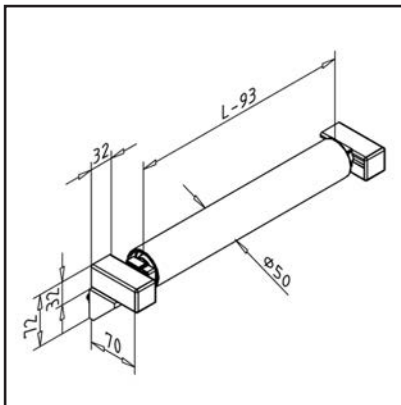

TECHN. DATA / ITEMS SUPPLIED

- With fastening material steel, zinc plated
- Support roller made of tube PVC
- Ball bearings on both sides
- Two holders from profile
- 2 mounting angles
- Max. tightening torque: 5 Nm
- **Please specify dimension L (belt width)**

APPLICATIONS

- MiniTec belt conveyor system
- As a support for the lower side of long belt conveyors
- We recommend to install one support roller for each intermediate support on the belt conveyor
- Use this support roller kit only with belt width > 115 mm

ASSEMBLY

- Reassemble the roller mount from the profile to the conveyor supports
- Clip support roller into fastening kit
- Slide the roller in appropriate position and tighten the screws

TRANSPORT ROLLER 50-25

Part no.

--...../-

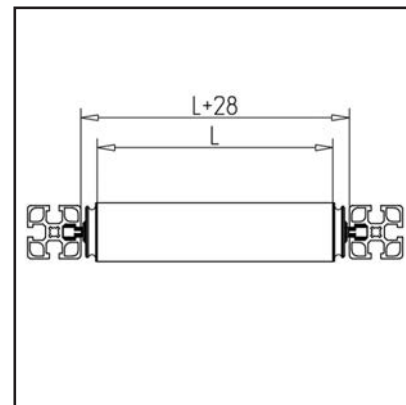
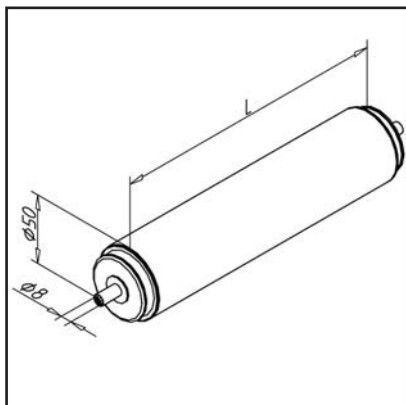
**TECHN. DATA / ITEMS SUPPLIED**

- Completely assembled conveyor roller optionally with PVC pipe in grey or Al-tube mill finished
- Load/roller max. 20 kg
- **Please specify dimension L** (pipe length)
- Conveyor roller PVC **part no. 21.0890/0**
- Conveyor roller Al **part no. 21.0892/0**
- On request also available with anodized aluminum tube or stainless steel tube

APPLICATIONS

- Production of roller conveyors with or without drive
- When requesting high concentricity, the conveyor roller AL is to be preferred

ASSEMBLY

- Simply attach roller carrier and insert in profile groove
- Use with roller carrier 25 **part no. 22.1196/0**

TRANSPORT ROLLER 50-36

Part no.

--...../-

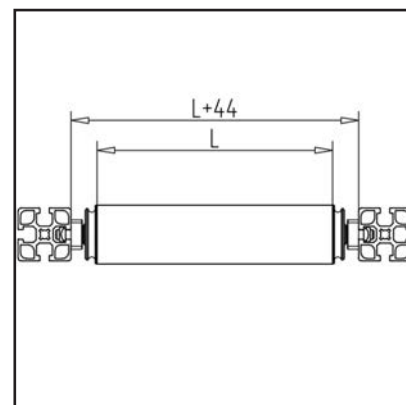
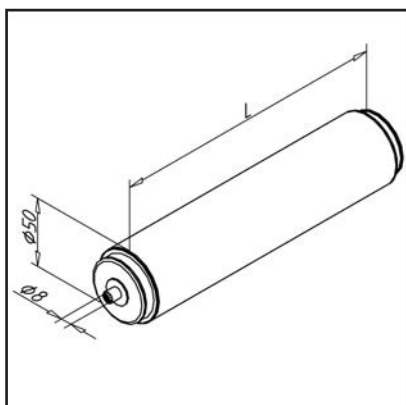
**TECHN. DATA / ITEMS SUPPLIED**

- Completely assembled conveyor roller optionally with PVC pipe in grey or Al-tube mill finished
- Load/roller max. 20 kg
- **Please specify dimension L** (pipe length)
- Conveyor roller PVC **part no. 21.1717/0**
- Conveyor roller Al **part no. 21.1716/0**
- On request also available with anodized aluminum tube or stainless steel tube

APPLICATIONS

- Production of roller conveyors with or without drive
- When requesting high concentricity, the conveyor roller AL is to be preferred

ASSEMBLY

- Clip in roller support
- Use with roller carrier 36 **part no. 22.1190/0**

TRANSPORT ROLLER S 50-25

Part no. ---,----/-

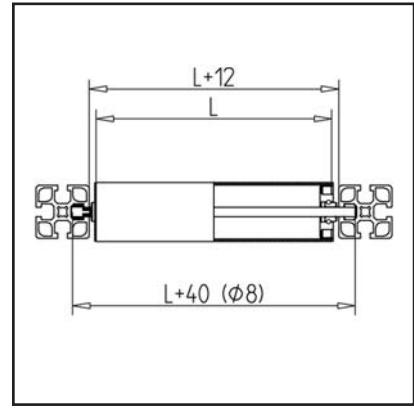
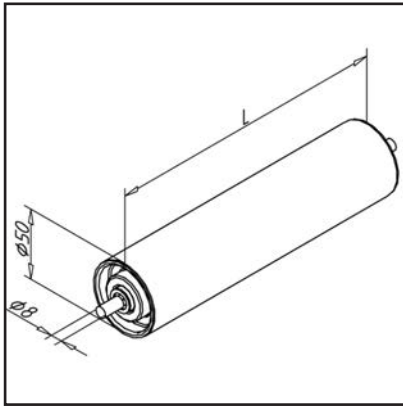

TECHN. DATA / ITEMS SUPPLIED

- Completely assembled conveyor roller optionally with PVC pipe in grey or Al-tube mill finished
- with ball bearing sets and continuous shaft
- Load/roller max. 33 kg
- **Please specify dimension L** (pipe length)
- Conveyor roller PVC **part no. 21.0891/0**
- Conveyor roller Al **part no. 21.0895/0**
- On request also available with anodized aluminum tube or stainless steel tube

APPLICATIONS

- Production of roller conveyors without drive
- When requesting high concentricity, the conveyor roller AL is to be preferred

ASSEMBLY

- Simply attach roller carrier and insert in profile groove
- Use with roller carrier 25 **part no. 22.1196/0**

TRANSPORT ROLLER S 50-36

Part no. ---,----/-

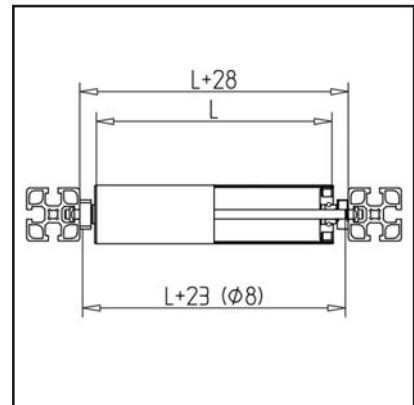
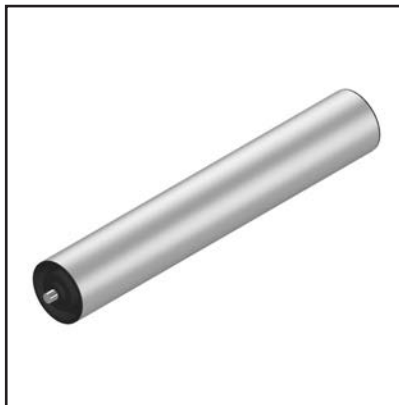
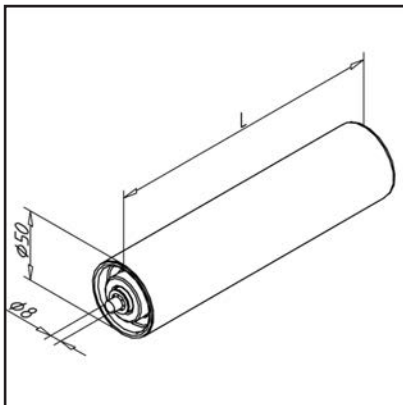

TECHN. DATA / ITEMS SUPPLIED

- Completely assembled conveyor roller optionally with PVC pipe in grey or Al-tube mill finished
- with ball bearing sets and continuous shaft
- Load/roller max. 33 kg
- **Please specify dimension L** (pipe length)
- Conveyor roller PVC **part no. 21.1719/0**
- Conveyor roller Al **part no. 21.1718/0**
- On request also available with anodized aluminum tube or stainless steel tube

APPLICATIONS

- Production of roller conveyors without drive
- When requesting high concentricity, the conveyor roller AL is to be preferred

ASSEMBLY

- Clip in roller support
- Use with roller carrier 36 **part no. 22.1190/0**

BRAKE ROLLER PVC 50

Part no.

21.2250/0

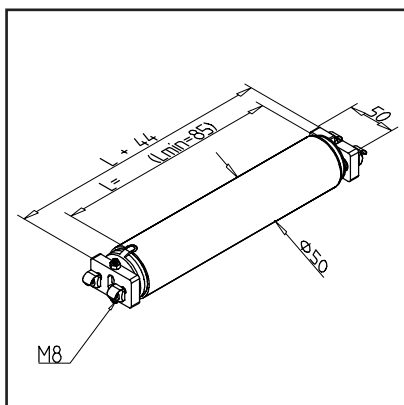
**TECHN. DATA / ITEMS SUPPLIED**

- With fastening material steel, zinc plated
- PVC, blue
- **Please specify dimension L** (pipe length)
- On request also available with tube in aluminum mill finished, anodized or stainless steel
- Weight = (basic weight) 0.295 kg
- Extra weight = 0.45 kg/m tube length

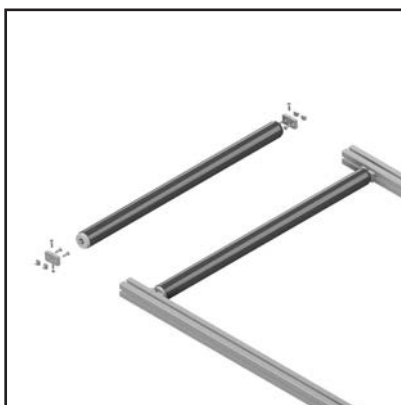
**APPLICATIONS**

- To decelerate transport boxes on sloped roller conveyors
- When it comes to the requirement for high concentricity, a tube made of aluminum or stainless steel is to be preferred

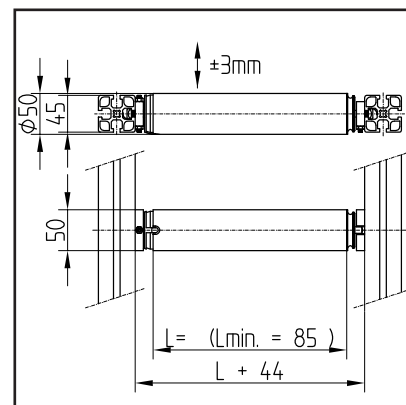
**ASSEMBLY**

- Mount lateral support on frame of roller conveyor
- Clamp the roller and adjust the height above the lower studs
- The brake-roller can be adjusted in height +/- 3 mm

PIPE 50 X 2

Part no.

--...../-

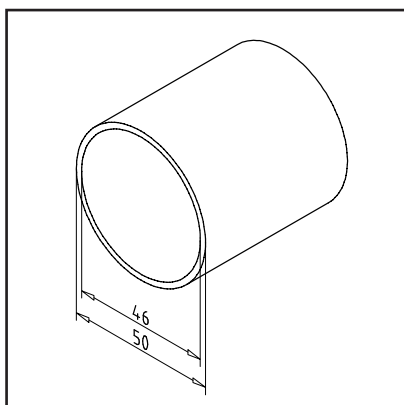
**TECHN. DATA / ITEMS SUPPLIED**

- PVC, grey **part no. 20.0992/0**
Weight: 0,45 kg/m, bar length 3 m
- Alu, bright rolled **part no. 20.1041/0**
Weight: 0,83 kg/m, bar length 6 m
- Alu, anodized **part no. 20.1041/1**
Weight: 0,83 kg/m, bar length 6 m
- SST **part no. 20.1089/0**
Weight: 2,37 kg/m, bar length 6 m

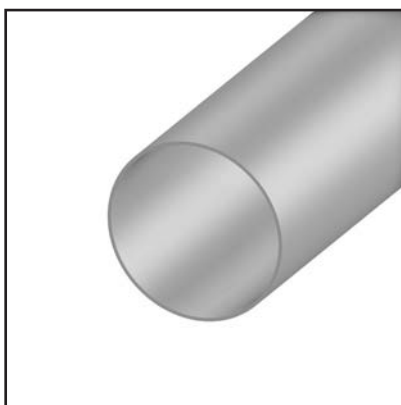
**APPLICATIONS**

- Production of conveyor rollers in any length for roller tracks with or without drive

**ASSEMBLY**

- Exemplary application see conveyor rollers 50 and conveyor rollers S 50

SET OF BEARINGS FOR CONVEYOR ROLLERS 25

Part no.

21.0894/0

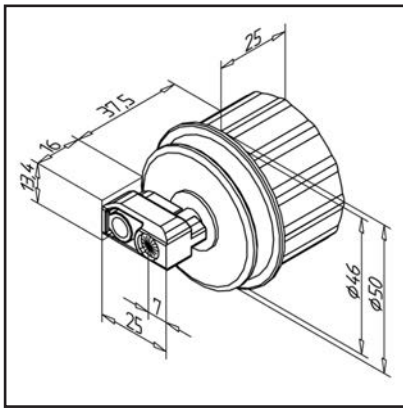

TECHN. DATA / ITEMS SUPPLIED

- Bearing bushing, PA 6
- Axle bolt, steel
- Roller carrier, ABS grey
- For conveyor rollers from 60 - 1000 mm
- Load/roller max. 20 kg
- Weight = 0.044 kg/piece

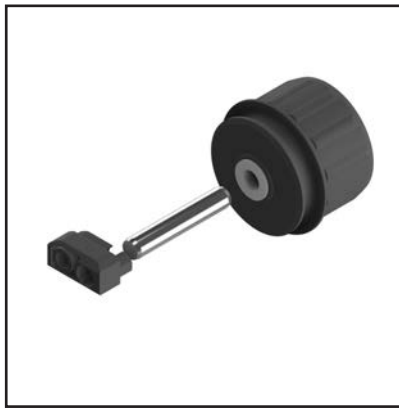

APPLICATIONS

- Roller tracks of unlimited length
- Drive via round belt \varnothing 5 mm possible

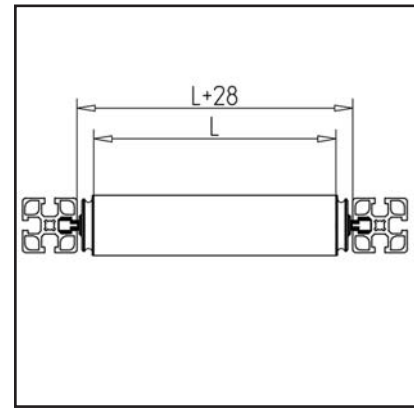

ASSEMBLY

- Assembly of the roller carrier on all profiles of profile series 45 possible
- Press bearing bush into the pipe
- Insert axle bolt in bearing bush
- Place roller carrier on axle and insert in profile groove
- For axial securing of the roller carriers we recommend to fix the terminal strips in the profile groove or to close the profile end with a cover AL

SET OF BEARINGS FOR CONVEYOR ROLLERS 36

Part no.

21.1056/0

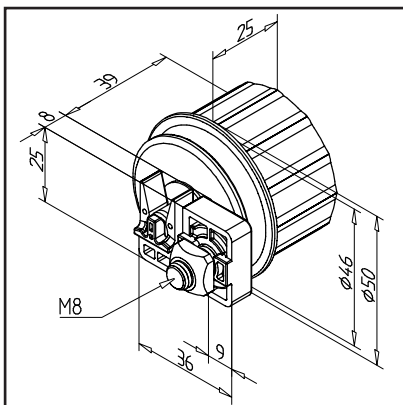

TECHN. DATA / ITEMS SUPPLIED

- With fastening material steel, zinc plated
- Bearing bushing, PA 6
- Axle bolt, steel
- Roller carrier, PP grey
- For conveyor rollers from 60 - 1000 mm
- Load/roller max. 20 kg
- Max. tightening torque: 5 Nm
- Weight = 0.057 kg/piece

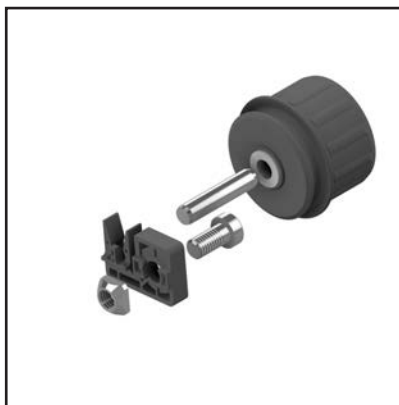

APPLICATIONS

- Roller tracks of unlimited length
- Drive via round belt \varnothing 5 mm possible
- Roles are individually interchangeable

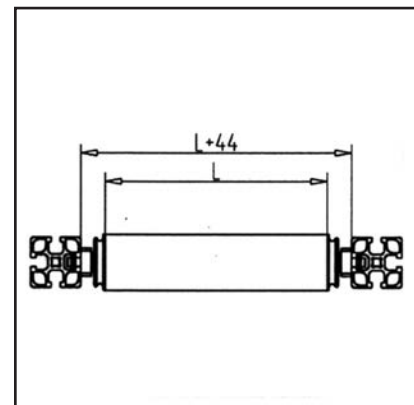

ASSEMBLY

- Assembly of the roller carrier on all profiles of profile series 45 possible
- Mount roller carrier to the profile
- Press bearing bush into the pipe
- Insert axle bolt in bearing bush
- Clip in transport roller

SET OF BEARINGS S 25

Part no.

21.0893/0

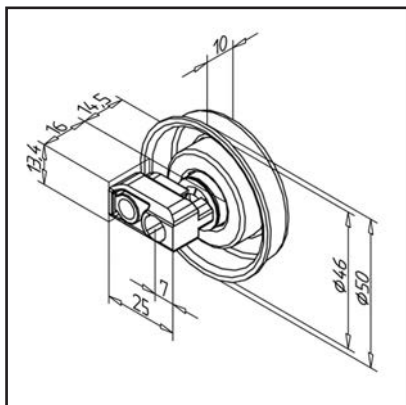

TECHN. DATA / ITEMS SUPPLIED

- Bearing bushing, steel, with ball bearing
- Locking clip, steel
- Roller carrier, ABS grey
- For conveyor rollers from 60 - 1000 mm
- Load/roller max. 33 kg
- Weight = 0.056 kg/piece

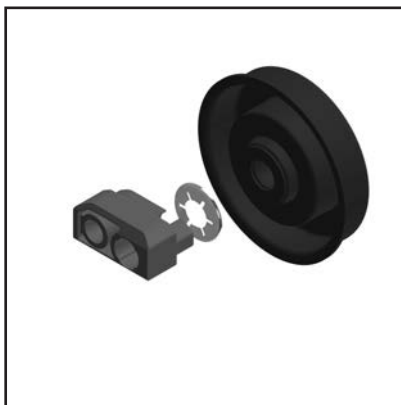

APPLICATIONS

- Roller tracks of unlimited length
- For the production of a conveyor roller is required:
 - 2x bearing set
 - 1x pipe PVC, aluminum or stainless steel in appropriate length
 - 1x steel shaft with $\varnothing 8$ mm **part no. 17.1840/0** in appropriate length

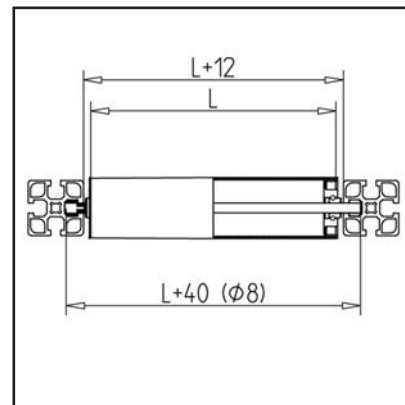

ASSEMBLY

- Assembly of the roller carrier on all profiles of profile series 45 possible
- Press bearing bush into the pipe
- Install shaft $\varnothing 8$ mm and secure with locking clip
- Place roller carrier on axle and insert in profile groove
- For axial securing of the roller carriers we recommend to fix the terminal strips in the profile groove or to close the profile end with a cover AL

SET OF BEARINGS S 36

Part no.

21.1722/0

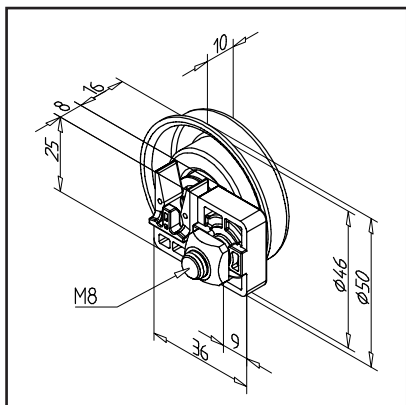

TECHN. DATA / ITEMS SUPPLIED

- With fastening material steel, zinc plated
- Bearing bushing, steel, with ball bearing
- Locking clip, steel
- Roller carrier, PP grey
- For conveyor rollers from 60 - 1000 mm
- Load/roller max. 33 kg
- Max. tightening torque: 5 Nm
- Weight = 0.070 kg/piece

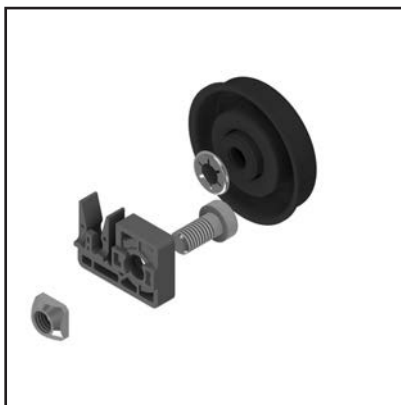

APPLICATIONS

- Roller tracks of unlimited length
- Roles are individually interchangeable
- For the production of a conveyor roller is required:
 - 2x bearing set
 - 1x pipe PVC, aluminum or stainless steel in appropriate length
 - 1x steel shaft with $\varnothing 8$ mm **part no. 17.1840/0** in appropriate length

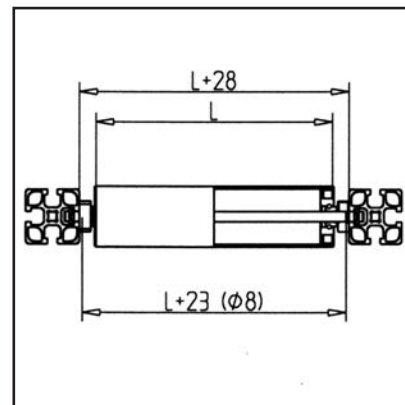

ASSEMBLY

- Assembly of the roller carrier on all profiles of profile series 45 possible
- Mount roller carrier to the profile
- Press bearing bush into the pipe
- Install shaft $\varnothing 8$ mm and secure with locking clip
- Clip in transport roller

ROLLER CARRIER 25

Part no. 22.1196/0

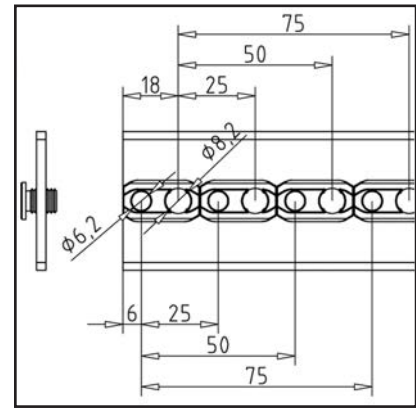
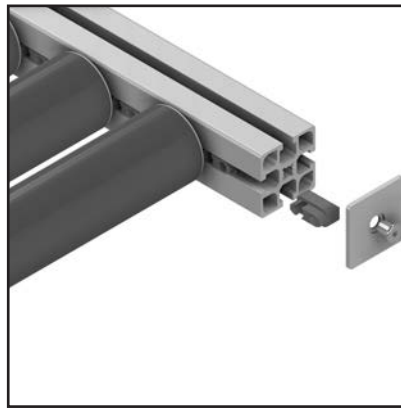
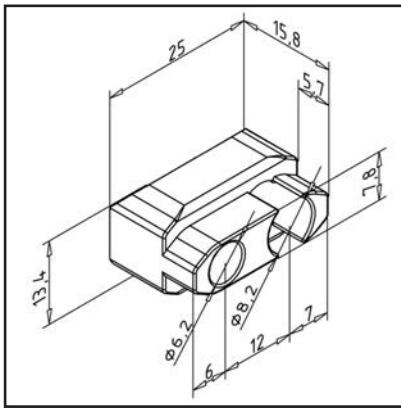

TECHN. DATA / ITEMS SUPPLIED

- ABS, Injection Mould, grey
- Load capacity 15 kg/carrier
- Weight = 0.003 kg/piece

APPLICATIONS

- For producing roller tracks with any roller division
- Minimum possible roll pitch 25 mm
- Roller axis \varnothing 8 mm

ASSEMBLY

- Place pulley carrier left and right onto the transport roller
- Insert transport roller with the pulley carrier into the profile grooves
- For axial support we recommend to insert an end cap AL according to the profile cross-section.
- Alternatively, also a T-slot bar or square nut with setscrew can be used

ROLLER CARRIER 36

Part no. 22.1190/0

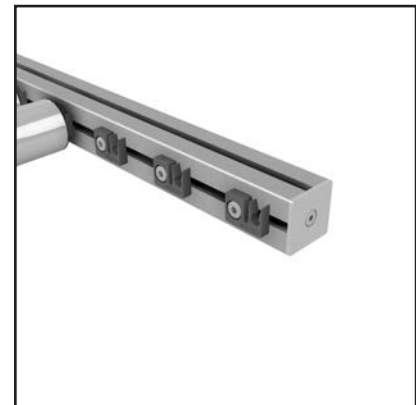
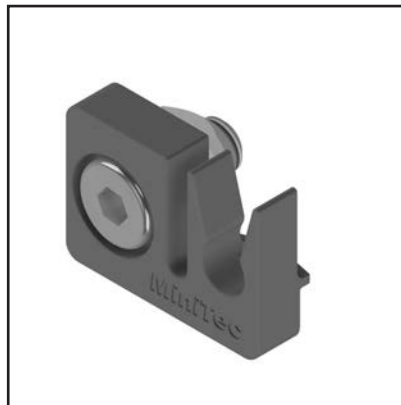
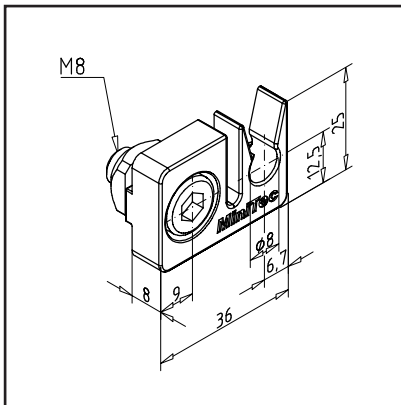

TECHN. DATA / ITEMS SUPPLIED

- PA, Injection Mould, grey
- Fastening material steel, galvanized
- Load capacity 15 kg/carrier
- Max. tightening torque: 5 Nm
- Weight = 0.017 kg/piece

APPLICATIONS

- For producing roller tracks with any roller division
- Smallest possible division of roles 36 mm
- Roller axis \varnothing 8 mm

ASSEMBLY

- Attach the roller carrier to the profile at the desired distance
- Insert axle of transport roller into pulley carrier

SPACER

Part no.

--...../-

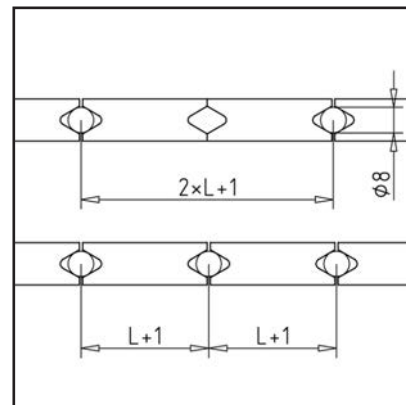
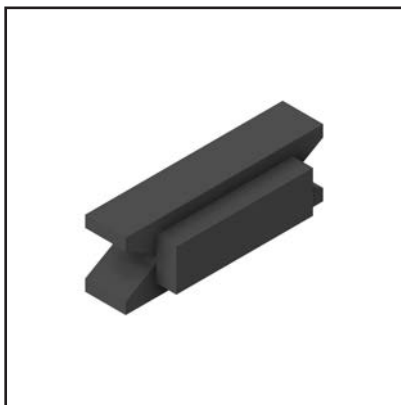
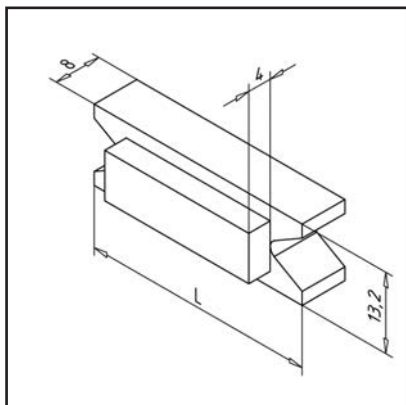

TECHN. DATA / ITEMS SUPPLIED

- PP, black
- Different versions:
Spacer 39, PP black, **part no. 22.1197/0**
Spacer 44, PP black, **part no. 22.1198/0**
- For shaft \varnothing 8 mm

APPLICATIONS

- For the preparation of roller conveyors with same division distances
- Suitable for all system grooves
- possible divisions 40 mm and 79 mm

ASSEMBLY

- Alternatively insert the spacer and the conveyor roller into the groove
- Clamp the first and the last spacer

LATERAL GUIDE 70 SUPPORT

Part no.

29.5025/0

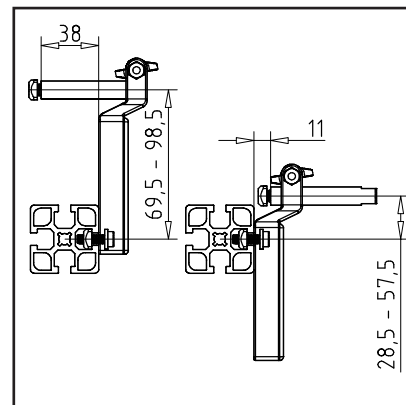
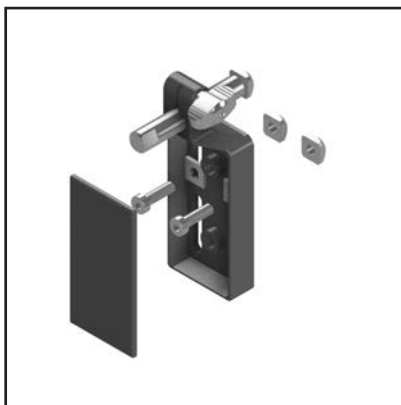
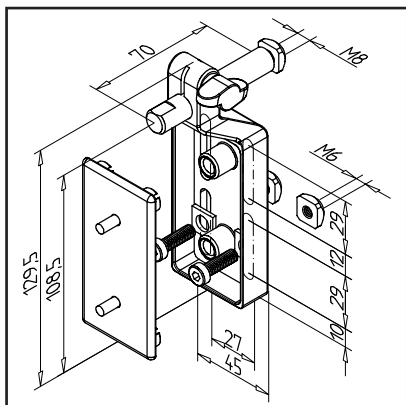

TECHN. DATA / ITEMS SUPPLIED

- PA, grey
- Distance bolt, stainless steel
- With fastening material steel, zinc plated
- Weight = 0.162 kg/piece

APPLICATIONS

- Adjustable lateral guides for MiniTec belt conveyors
- Recommended distance from single holder approx. 500 mm

ASSEMBLY

- Set the height and tighten the screws
- Install lateral guidance, lateral guidance F or lateral guidance 40F
- Adjust lateral distance bolt

LATERAL GUIDE 140 SUPPORT

Part no.

29.5028/0

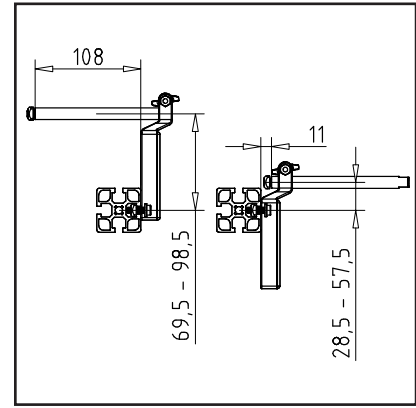
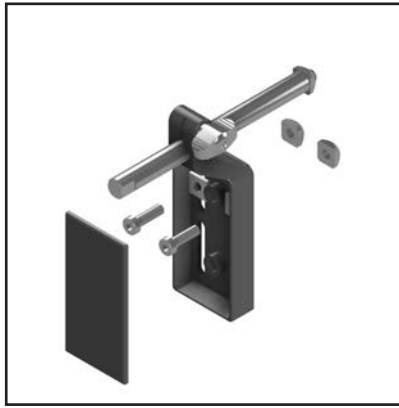
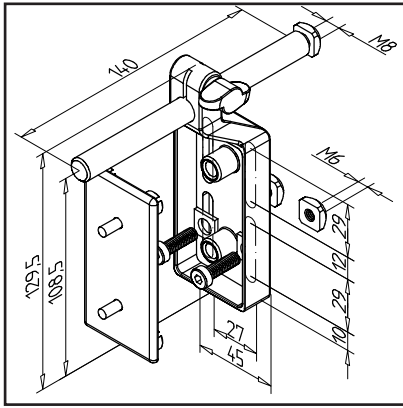

TECHN. DATA / ITEMS SUPPLIED

- PA, grey
- Distance bolt, stainless steel
- With fastening material steel, zinc plated
- Weight = 0.223 kg/piece

APPLICATIONS

- Adjustable side guide on MiniTec roller tracks
- Recommended distance from single holder approx. 500 mm

ASSEMBLY

- Set the height and tighten the screws
- Install lateral guidance, lateral guidance F or lateral guidance 40F
- Adjust lateral distance bolt

LATERAL GUIDE 140 SUPPORT S

Part no.

29.5055/0

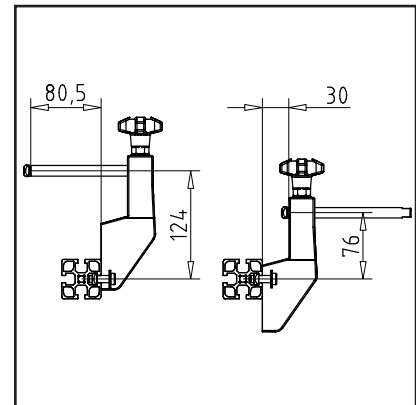
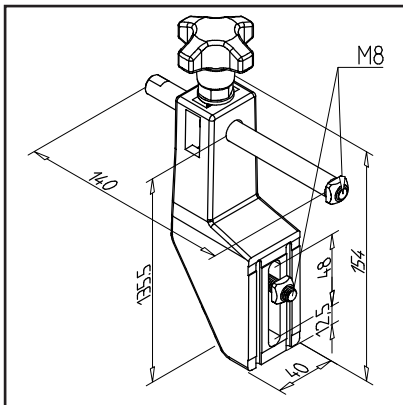

TECHN. DATA / ITEMS SUPPLIED

- PA, grey
- With fastening material steel, zinc plated
- Distance bolt, stainless steel
- Weight = 0.350 kg/piece

APPLICATIONS

- Adjustable lateral guides for MiniTec belt conveyors
- Recommended distance from single holder approx. 500 mm

ASSEMBLY

- Set the height and tighten the screws
- Install lateral guidance, lateral guidance F or lateral guidance 40F
- Adjust lateral distance bolt

LATERAL GUIDE 70 SUPPORT S

Part no.

29.5056/0

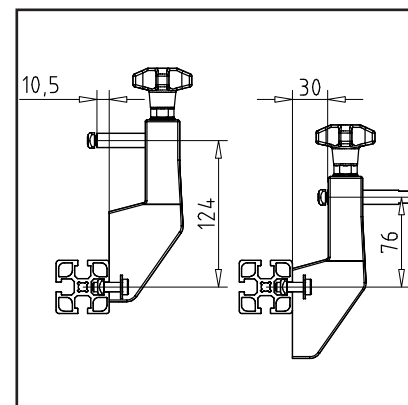
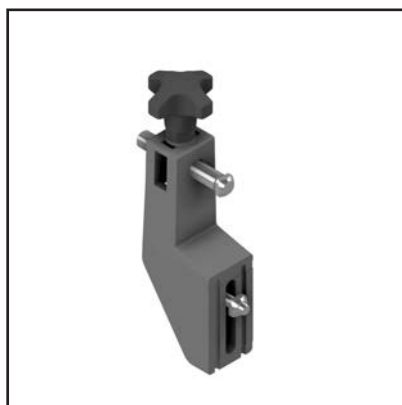
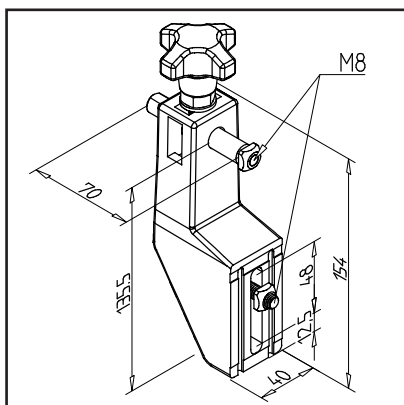
**TECHN. DATA / ITEMS SUPPLIED**

- PA, grey
- With fastening material steel, zinc plated
- Distance bolt, stainless steel
- Weight = 0.288 kg/piece

APPLICATIONS

- Adjustable lateral guides for MiniTec belt conveyors
- Recommended distance from single holder approx. 500 mm

ASSEMBLY

- Set the height and tighten the screws
- Install lateral guidance, lateral guidance F or lateral guidance 40F
- Adjust lateral distance bolt

LATERAL GUIDE SUPPORT, SHORT

Part no.

29.5046/0

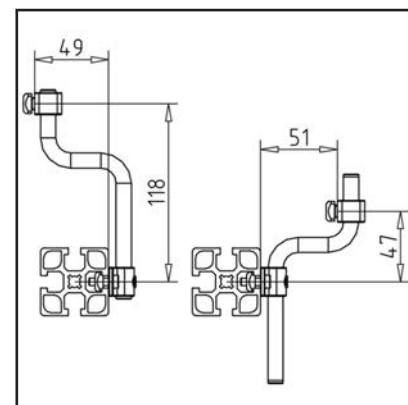
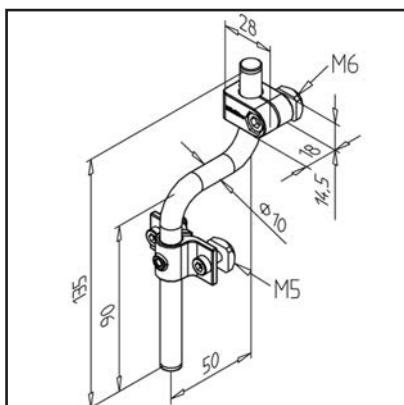
**TECHN. DATA / ITEMS SUPPLIED**

- Stainless steel
- Holder on top, ABS, grey
- Adjusting rod and holder at the bottom, stainless steel
- With fastening material steel, zinc plated
- Weight = 0.097 kg/piece

APPLICATIONS

- Adjustable lateral guide for MiniTec roller conveyor, conveyor belt etc.
- we recommend approx. 300 mm distance between the supports

ASSEMBLY

- slide square nut into base frame of conveyor and adjust the support
- adjust height and distance
- Install lateral guidance, lateral guidance F or lateral guidance 40F

LATERAL GUIDE SUPPORT, LONG

Part no.

29.5047/0

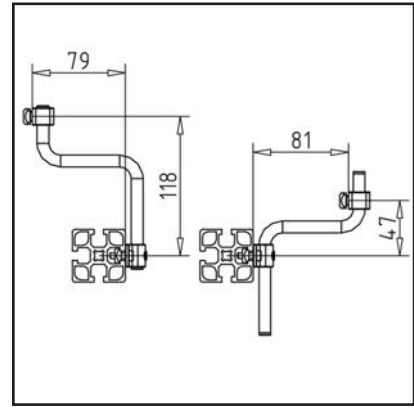
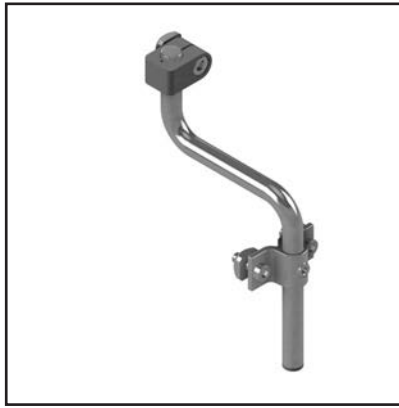
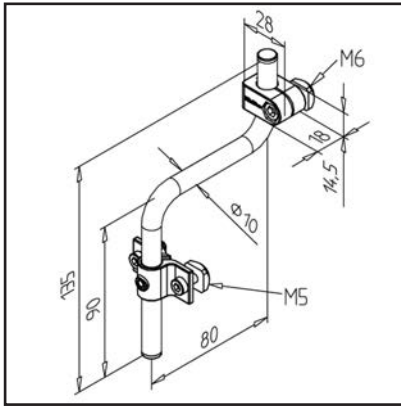

TECHN. DATA / ITEMS SUPPLIED

- Stainless steel
- Holder on top, ABS, grey
- Adjusting rod and holder at the bottom, stainless steel
- With fastening material steel, zinc plated
- Weight = 0.104 kg/piece

APPLICATIONS

- Adjustable lateral guide for MiniTec roller conveyor, conveyor belt etc.
- we recommend approx. 300 mm distance between the supports
- Larger adjustment range of lateral support **part no. 29.5047/0**

ASSEMBLY

- slide square nut into base frame of conveyor and adjust the support
- adjust height and distance
- Install lateral guidance, lateral guidance F or lateral guidance 40F

LATERAL GUIDE SUPPORT U-SHAPED

Part no.

29.5048/0

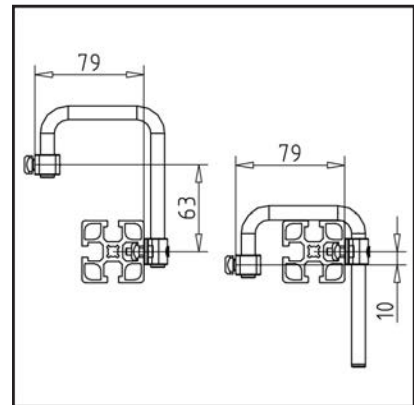
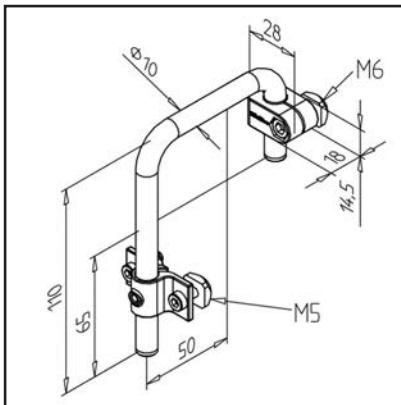

TECHN. DATA / ITEMS SUPPLIED

- Stainless steel
- Holder on top, ABS, grey
- Adjusting rod and holder at the bottom, stainless steel
- With fastening material steel, zinc plated
- Weight = 0.108 kg/piece

APPLICATIONS

- Adjustable lateral guide for MiniTec roller conveyor, conveyor belt etc.
- we recommend approx. 300 mm distance between the supports
- Lateral guide can be completely pushed down onto the roller conveyor or belt conveyor, for flat goods to be conveyed

ASSEMBLY

- slide square nut into base frame of conveyor and adjust the support
- adjust height and distance
- Install lateral guidance, lateral guidance F or lateral guidance 40F

CLAMP HOLDER 10

Part no.

29.5052/0

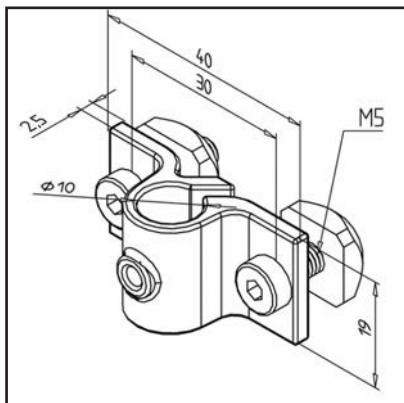
**TECHN. DATA / ITEMS SUPPLIED**

- Stainless steel, blasted
- With fastening material steel, zinc plated
- 1.4301 / steel zinc plated
- Weight = 0.043 kg/piece

**APPLICATIONS**

- Adjustable lateral guides for MiniTec belt conveyors
- Recommended distance from single holder approx. 500 mm

**ASSEMBLY**

- Fasten on profile groove

LATERAL GUIDE CONVEYOR BELT

Part no.

29.5034/0

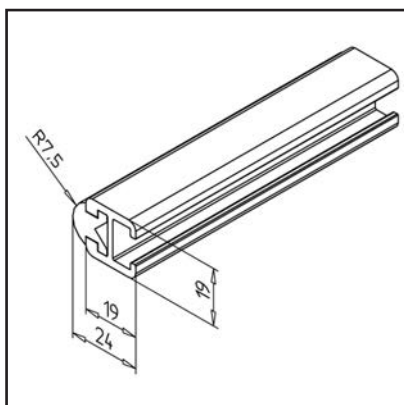
**TECHN. DATA / ITEMS SUPPLIED**

- Aluminium, E6/EV1
- Slide profile, PE, natural
- Bar length = 6 m

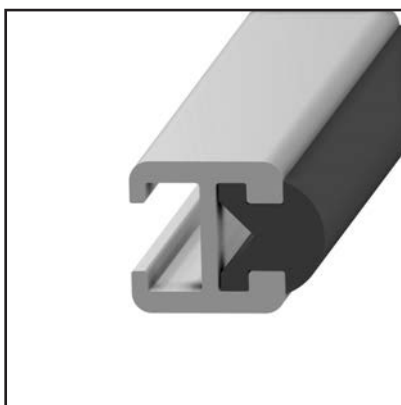
**APPLICATIONS**

- Recommended length: axial distance A + 40 mm
- Adjustable lateral guides for MiniTec belt conveyors

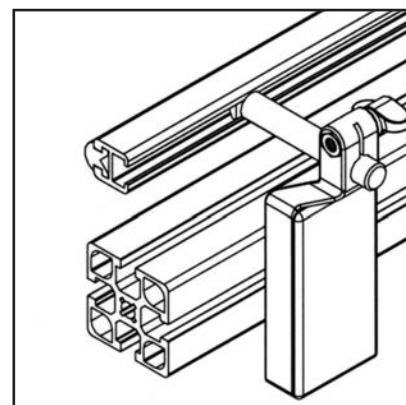
**ASSEMBLY**

- Square nut M8 from mounting kit for holder side guide into receiving groove
- Screw the lateral guide on the distance bolt
- suitable end cap **part no. 22.1180/0**

LATERAL GUIDE F

Part no. 29.5049/0

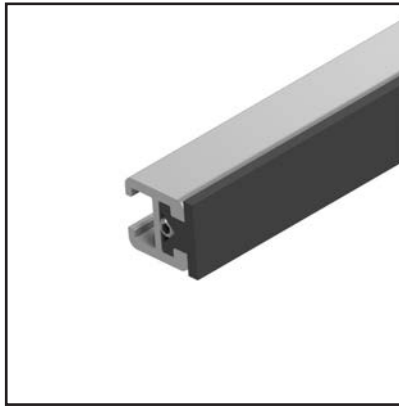
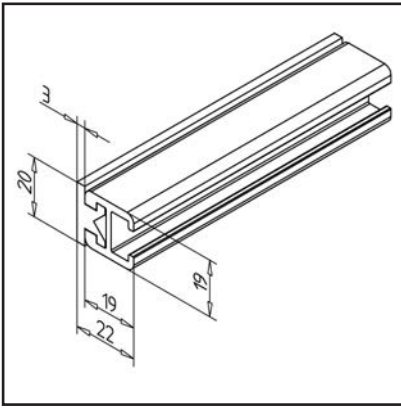

TECHN. DATA / ITEMS SUPPLIED

- Aluminium, E6/EV1
- Slide profile, PE, natural
- Bar length = 6 m

APPLICATIONS

- adjustable lateral guidance for MiniTec chain conveyors, belt conveyors and roller conveyors

ASSEMBLY

- Square nut M8 from mounting kit for holder side guide into receiving groove
- Fix the holder to the side guide and adjust it
- suitable end cap **part no. 22.1180/0**

SIDE GUIDE 40 F WHITE

Part no. 29.5051/0

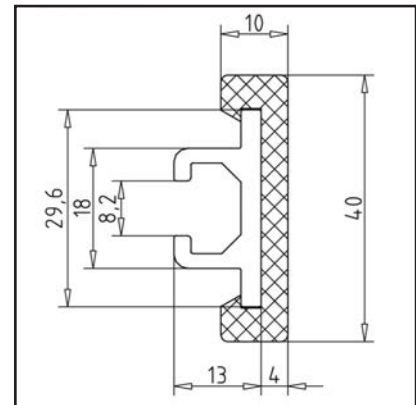
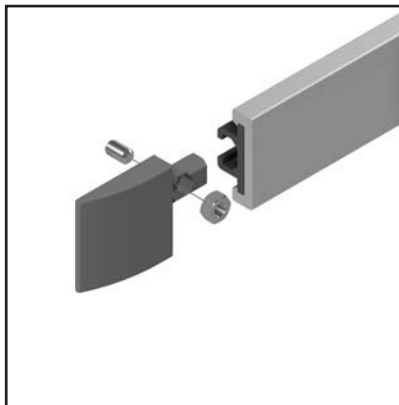
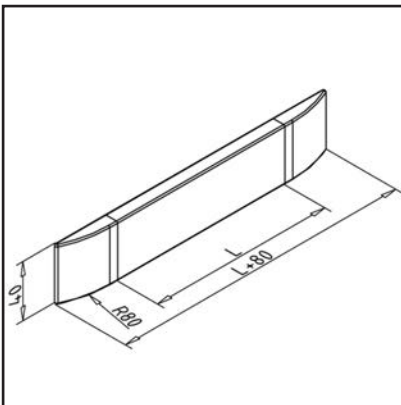

TECHN. DATA / ITEMS SUPPLIED

- Aluminium, E6/EV1
- Sliding profile PE, white
- 2 x slide PA, grey
- Other colours and designs on request, e.g. green, black, grey, black antistatic
- Bar length = 6 m

APPLICATIONS

- adjustable lateral guidance for MiniTec chain conveyors, belt conveyors and roller conveyors

ASSEMBLY

- Square nut M8 from mounting kit for holder side guide into receiving groove
- Fix the holder to the side guide and adjust it

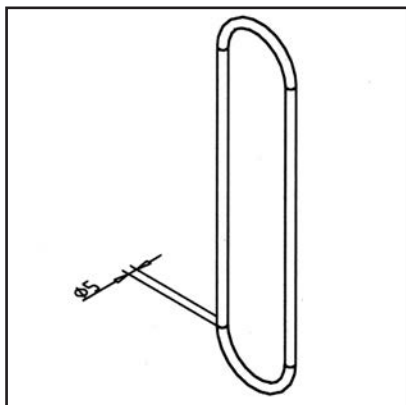
DRIVE BELT NBR**TECHN. DATA / ITEMS SUPPLIED**

- NBR, black
- Ø 5 mm
- Available lengths:
 - part no.. 21.1050/1** for A = 66 mm
 - part no.. 21.1050/2** for A = 90 mm
 - part no.. 21.1050/3** for A = 121 mm
 - part no.. 21.1050/4** for A = 149 mm
 - part no.. 21.1050/5** for A = 176 mm
 - part no.. 21.1050/6** for A = 215 mm
 - other lengths and designs on request

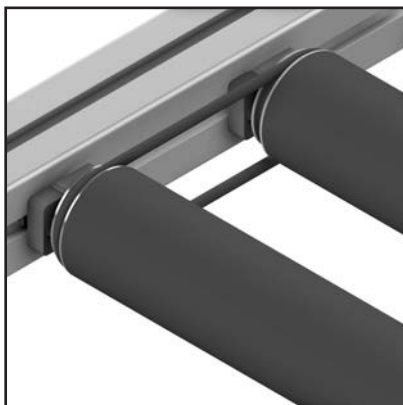
**APPLICATIONS**

- Drive the rollers with each other via the groove in the bearing sets. Preferably realize inaccessible places

Part no.

--...../-

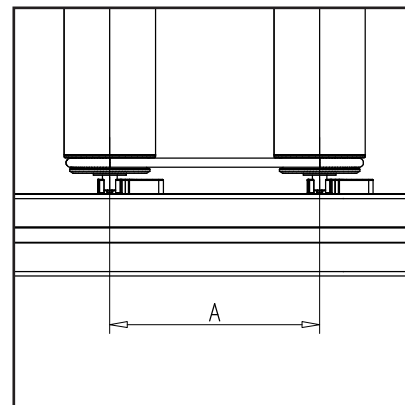
**ASSEMBLY**

- Insert the belt into the groove of the first roller and clip the roller into the bearing set
- Strap the belt over the second roller and, under tension, clip the roller into the bearing set

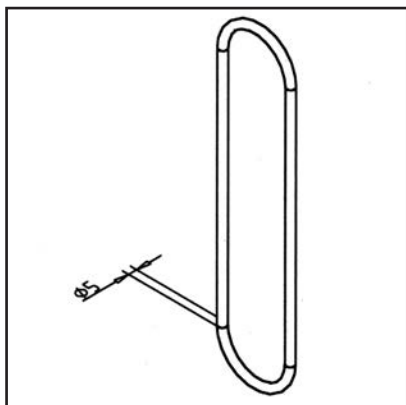
DRIVE BELT PU**TECHN. DATA / ITEMS SUPPLIED**

- PU, green
- Ø 5 mm
- Endless length 550 mm
- Weight = 0.050 kg/piece

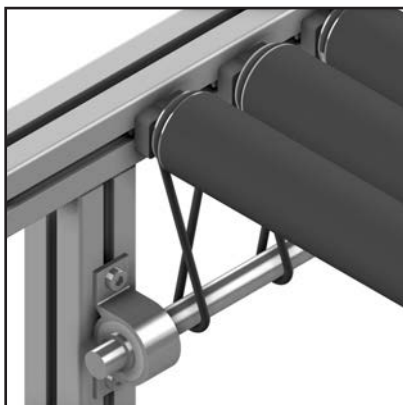
**APPLICATIONS**

- Drive of conveyor rollers via king shaft
- When driving roller pairs, one obtains a center distance A = 207 mm

Part no.

21.1050/7

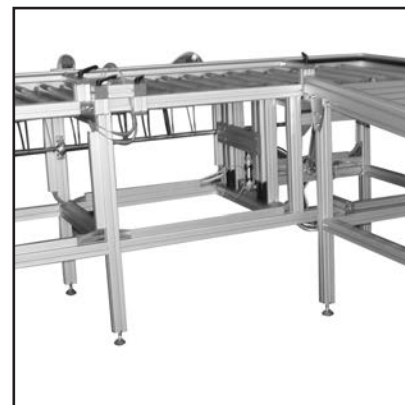
**ASSEMBLY**

- Strip driving belt over driving shaft
- Strap the belt over individual rollers and clip
- Rolls in inaccessible places with drive belt NBR **part no. 21.1050/1** bis **part no. 21.1050/6** connect

SUPPORT BEARING 20

Part no.

50.0128/0

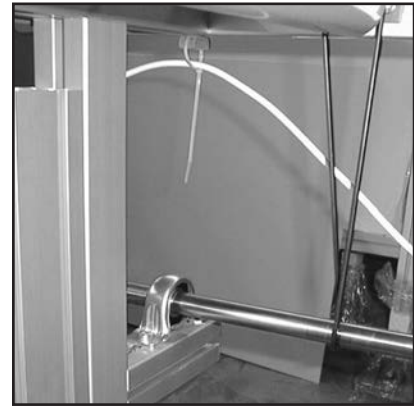
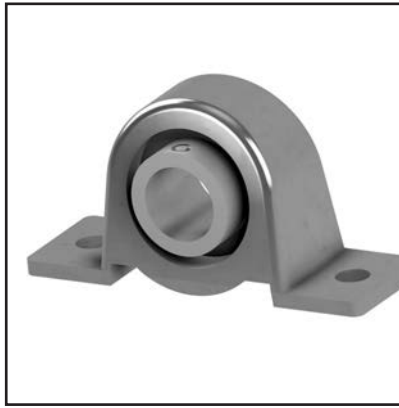
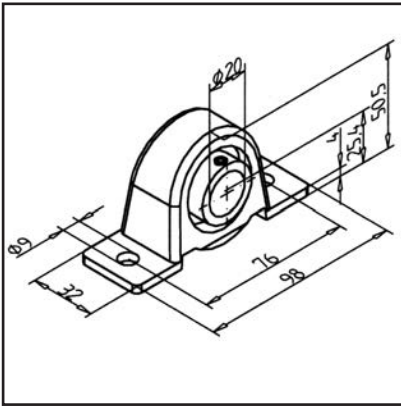

TECHN. DATA / ITEMS SUPPLIED

- With fastening material steel, zinc plated
- Pedestal bearing steel, galvanized
- Bore \varnothing 20 mm
- stat. C0 = 6350 N
- dyn. C = 13000 N
- Weight = 0.210 kg/piece

APPLICATIONS

- Production of roller tracks with drive in any length
- Drive of conveyor rollers via king shaft

ASSEMBLY

- With fastening material included
- Lead shaft trough bearing and secure with set screw

TRANSFER SYSTEM TSG

MODULAR, ECONOMICAL, ROBUST

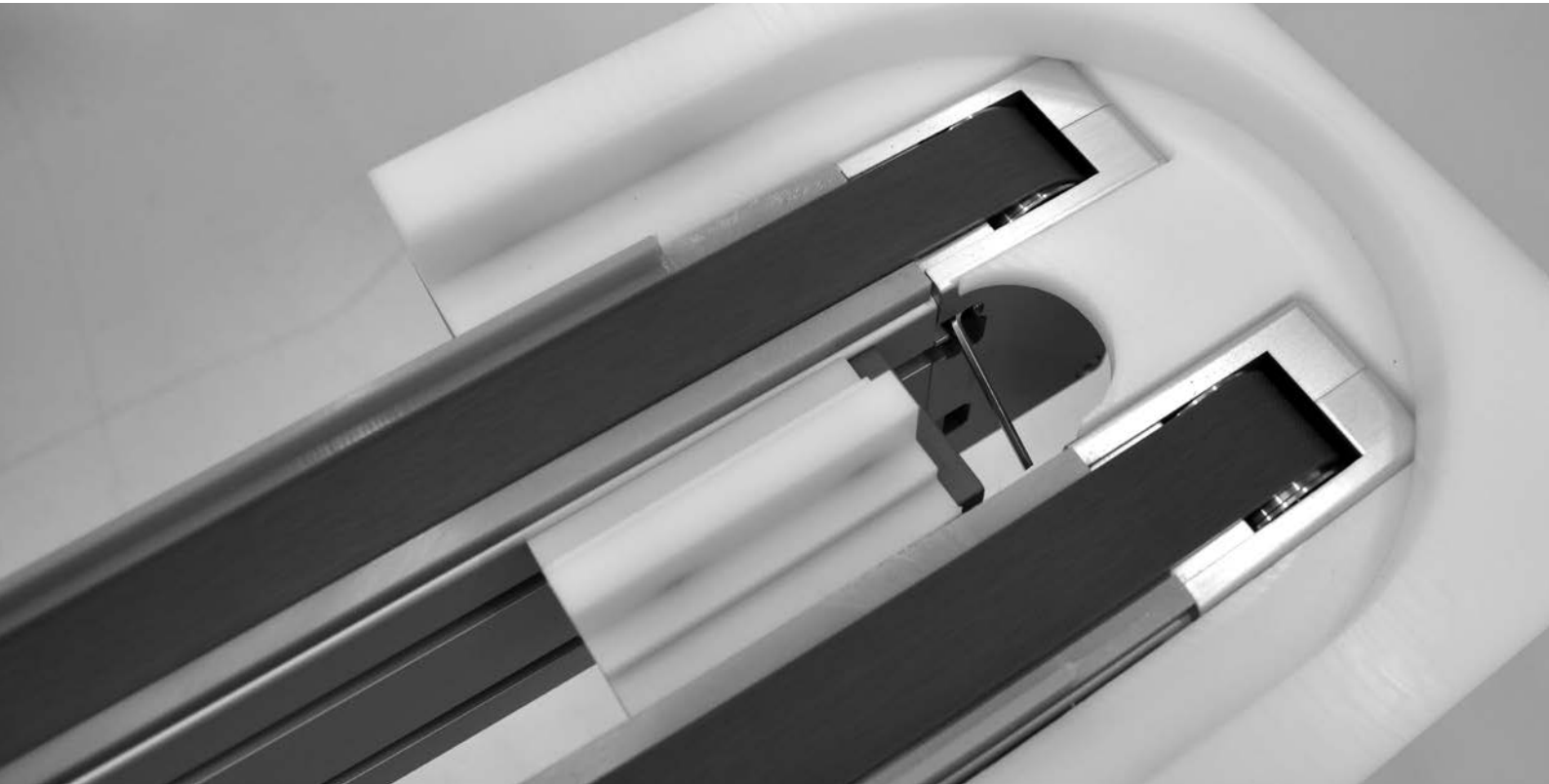

Flexibility in production is becoming increasingly important. Quick and easy adaptation to product development or changed market requirements are a decisive factor for success. The TSG transfer system corresponds to this trend. All advantages of our modular system for mechanical engineering and the precision of our linear system are used in this system. TSG is fully compatible with the proven MiniTec profile system with workstations, protective equipment, conveyor systems, handling equipment etc. Manual stations and complex automated processes can be realized economically with the TSG transfer system. It is a particularly economical solution for low unit weights. The TSG

transfer system consists of standardized modules that can be combined as required to form customized systems. Robust timing belts 25 T5 with steel reinforcement ensure continuous operation without re-tensioning. The TSG transfer systems are available as modules for installation by the customer or as ready-to-operate systems, including commissioning. Planning and layout of the plant can also be carried out by us according to customer specifications. For simple requirements, checklists can be used in the appendix of this catalogue.

Technical Data**Travel Speed:** 11 m/min***Motor Rated Power:** 120 W**Rated voltage (without frequency converter):** 400 V/50 Hz**Rated voltage (with frequency converter):** 230 V/50 Hz
Rated current: 0,29 A**Output speed:** 64 1/min**Output torque:** 13 Nm**Line load:** 1710 N**Ambient temperature:** 0° to 50°C

*Further travel speeds are available in the range 5.5 to 21 m/min. The maximum line load is 1710 N. At speeds greater than 11 m/min, the maximum line load is reduced.

TRANSFER SYSTEM TSG

POSSIBLE CONSTRUCTIONS & VERSIONS

Vertical circulation

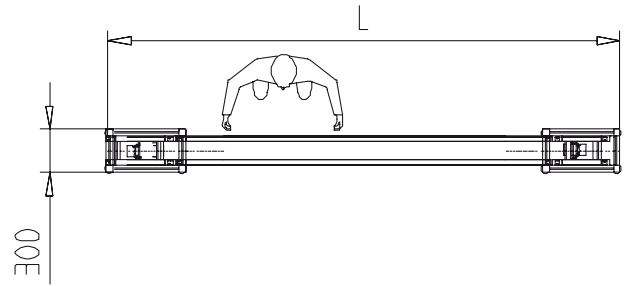
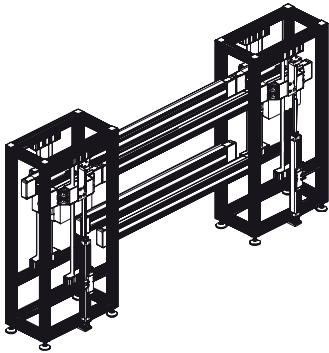

Advantage: low space requirement

Base circulation 90°

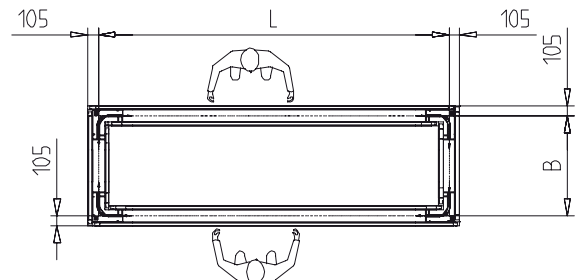
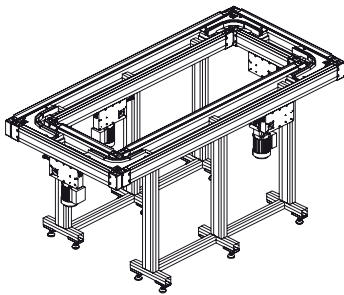

Advantages: low investment, simple installation, minimal control effort

Compact Circulating 180°

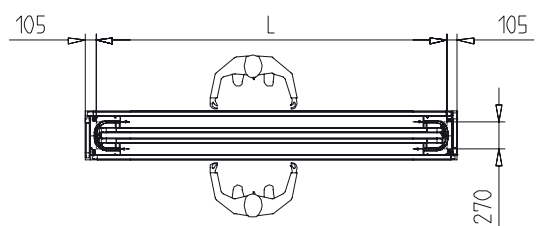
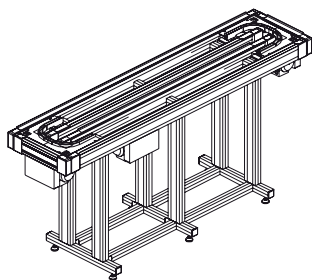

Advantage: low space requirement and capital expenditure, simple installation, minimal control effort

U-Circulation with lifting station

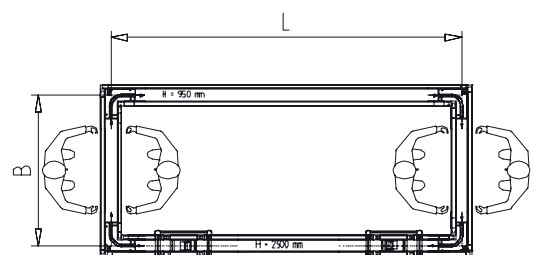
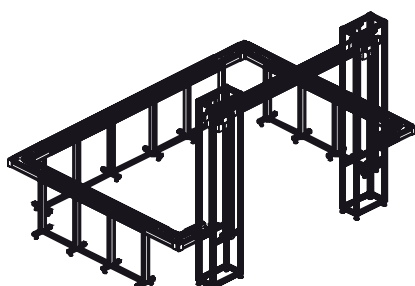

Advantage: great accessibility and optimal land use

TRANSFER SYSTEM TSG

POSSIBLE CONSTRUCTIONS & VERSIONS

Double U-circulation

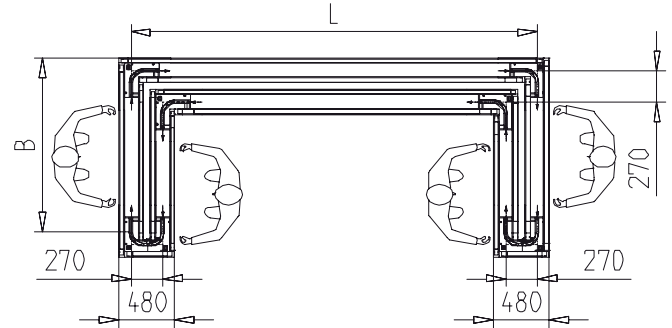
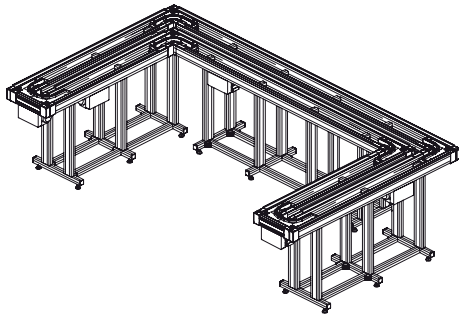

Advantage: optimal use of space, availability of the entire conveyor line

Inquiry Sub-Enclosure

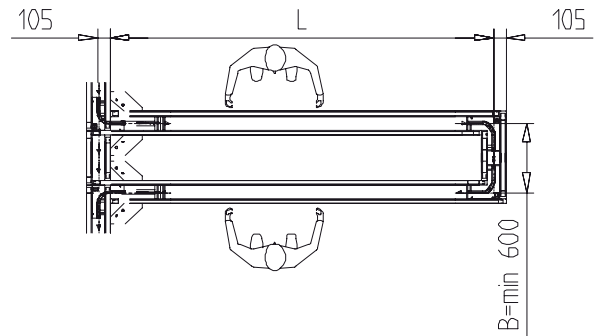
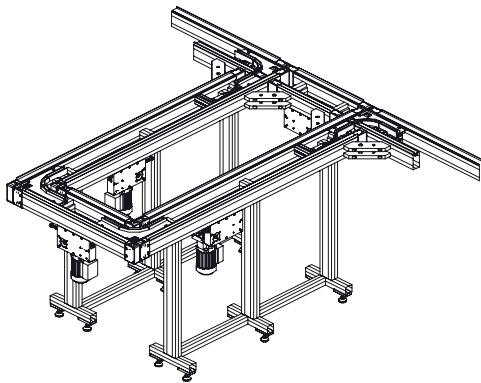

Advantage: Cycle-decoupled production, high conversion and quantity flexibility

Combination of different variants

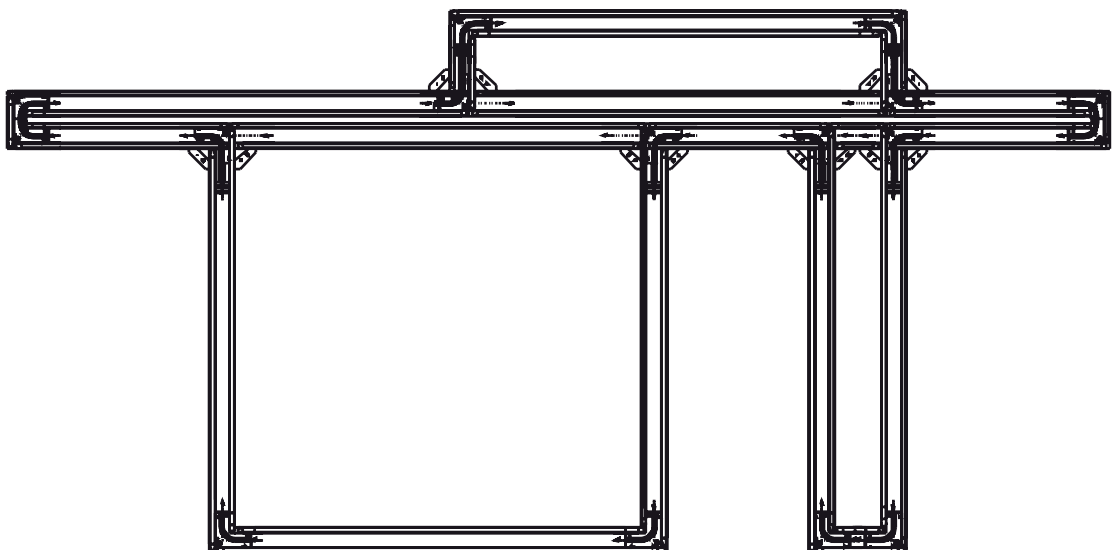

Advantage: optimal use of space, availability of the entire conveyor line

TRANSFER SYSTEM TSG

INQUIRY VERTICAL CIRCUIT TSG 200

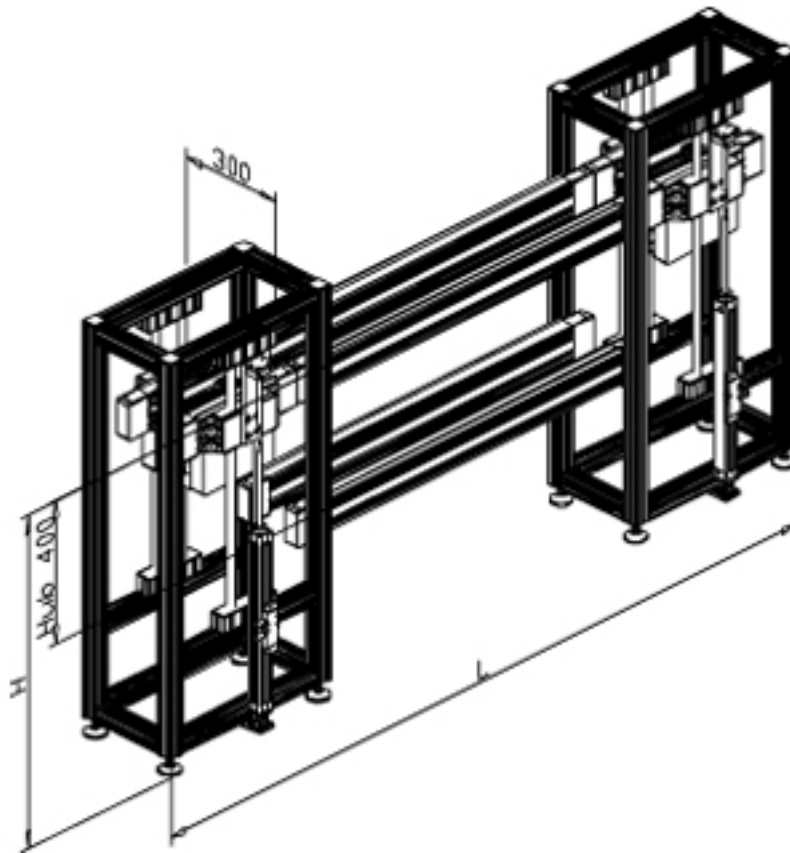

Measure L	<input type="text"/>	mm
Working height	<input type="text"/>	mm
Number of stoppers	<input type="text"/>	Pcs.
Number of positioners	<input type="text"/>	Pcs.
Number of lifting stations	<input type="text"/>	
Transport direction	<input type="checkbox"/> right <input type="checkbox"/> left	
Speed	<input type="text"/>	m/min.
Frequency converter	<input type="checkbox"/> yes <input type="checkbox"/> no	
Control	<input type="text"/>	
Number of sensors	<input type="text"/>	Pcs.
Number of workpiece carriers	<input type="text"/>	Pcs.

Contact details

Company	<input type="text"/>	<input type="checkbox"/> Please call me back
Contact	<input type="text"/>	<input type="checkbox"/> I ask for a written offer
Phone number	<input type="text"/>	
Fax number	<input type="text"/>	
E-Mail	<input type="text"/>	

TRANSFER SYSTEM TSG

INQUIRY BASIC CIRCUIT 90° TSG 200

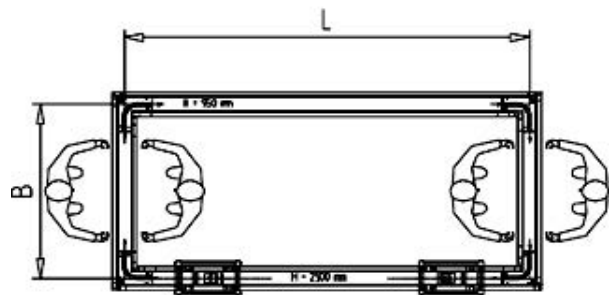
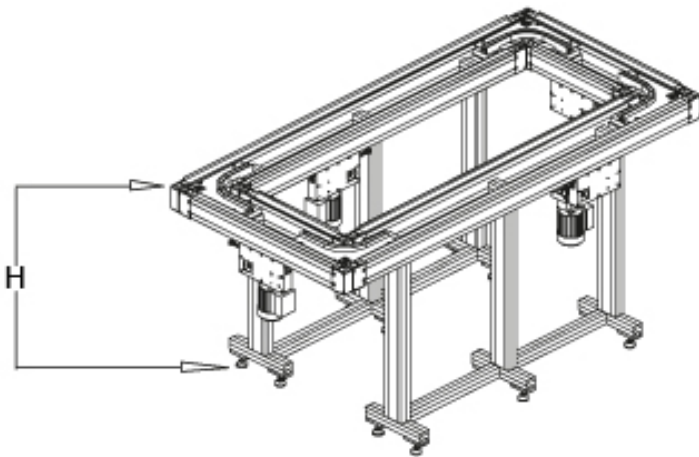

Measure L	<input type="text"/>	mm
Working height H (WT upper edge)	<input type="text"/>	mm
Number of stoppers	<input type="text"/>	Pcs.
Number of positioners	<input type="text"/>	Pcs.
Number of lifting stations	<input type="text"/>	
Transport direction	<input type="checkbox"/> right <input type="checkbox"/> left	
Speed	<input type="text"/>	m/min.
Frequency converter	<input type="checkbox"/> yes <input type="checkbox"/> no	
Control	<input type="text"/>	
Number of sensors	<input type="text"/>	Pcs.
Number of workpiece carriers	<input type="text"/>	Pcs.

Contact details

Company	<input type="text"/>	<input type="checkbox"/> Please call me back
Contact	<input type="text"/>	<input type="checkbox"/> I ask for a written offer
Phone number	<input type="text"/>	
Fax number	<input type="text"/>	
E-Mail	<input type="text"/>	

TRANSFER SYSTEM TSG

INQUIRY COMPACT CIRCUIT 180° TSG 200

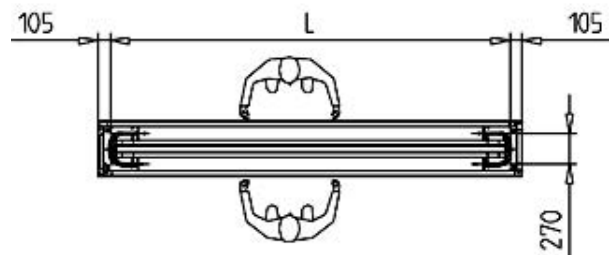
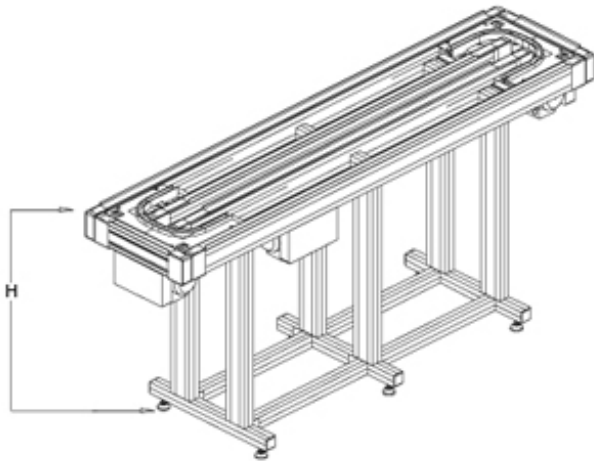

Measure L	<input type="text"/>	mm
Working height H (WT upper edge)	<input type="text"/>	mm
Number of stoppers	<input type="text"/>	Pcs.
Number of positioners	<input type="text"/>	Pcs.
Number of lifting stations	<input type="text"/>	
Transport direction	<input type="checkbox"/> right <input type="checkbox"/> left	
Speed	<input type="text"/>	m/min.
Frequency converter	<input type="checkbox"/> yes <input type="checkbox"/> no	
Control	<input type="text"/>	
Number of sensors	<input type="text"/>	Pcs.
Number of workpiece carriers	<input type="text"/>	Pcs.

Contact details

Company	<input type="text"/>	<input type="checkbox"/> Please call me back
Contact	<input type="text"/>	<input type="checkbox"/> I ask for a written offer
Phone number	<input type="text"/>	
Fax number	<input type="text"/>	
E-Mail	<input type="text"/>	

TRANSFER SYSTEM TSG

INQUIRY U-CIRCUIT WITH LIFTING STATION TSG 200

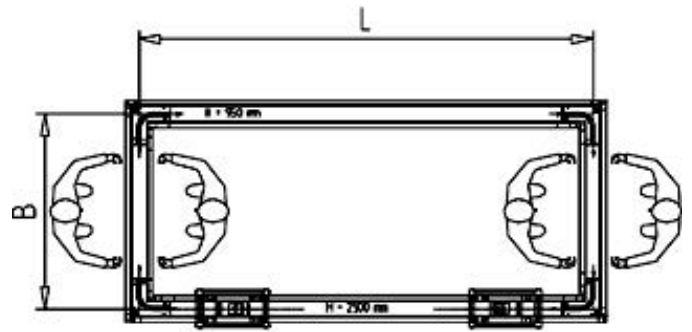
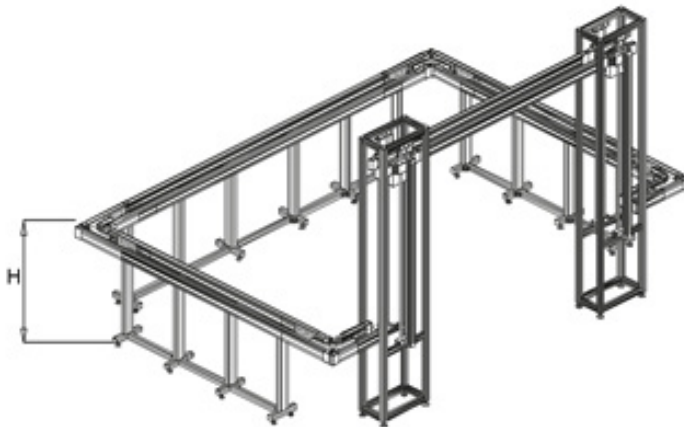

Measure L	<input type="text"/>	mm
Working height H (WT upper edge)	<input type="text"/>	mm
Number of stoppers	<input type="text"/>	Pcs.
Number of positioners	<input type="text"/>	Pcs.
Number of lifting stations	<input type="text"/>	
Transport direction	<input type="checkbox"/> right <input type="checkbox"/> left	
Speed	<input type="text"/>	m/min.
Frequency converter	<input type="checkbox"/> yes <input type="checkbox"/> no	
Control	<input type="text"/>	
Number of sensors	<input type="text"/>	Pcs.
Number of workpiece carriers	<input type="text"/>	Pcs.

Contact details

Company	<input type="text"/>	<input type="checkbox"/> Please call me back
Contact	<input type="text"/>	<input type="checkbox"/> I ask for a written offer
Phone number	<input type="text"/>	
Fax number	<input type="text"/>	
E-Mail	<input type="text"/>	

TRANSFER SYSTEM TSG

INQUIRY DOUBLE-U CIRCUIT TSG 200

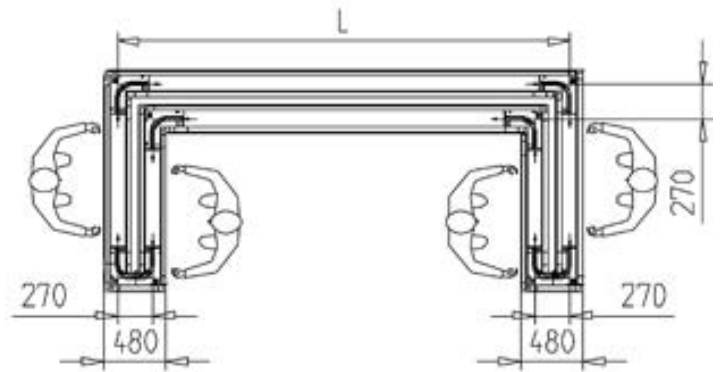
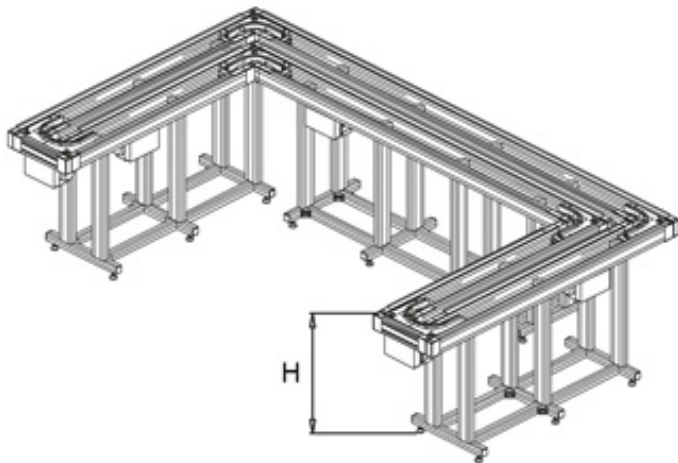

Measure L	<input type="text"/>	mm
Working height H (WT upper edge)	<input type="text"/>	mm
Number of stoppers	<input type="text"/>	Pcs.
Number of positioners	<input type="text"/>	Pcs.
Number of lifting stations	<input type="text"/>	
Transport direction	<input type="checkbox"/> right <input type="checkbox"/> left	
Speed	<input type="text"/>	m/min.
Frequency converter	<input type="checkbox"/> yes <input type="checkbox"/> no	
Control	<input type="text"/>	
Number of sensors	<input type="text"/>	Pcs.
Number of workpiece carriers	<input type="text"/>	Pcs.

Contact details

Company	<input type="text"/>	<input type="checkbox"/> Please call me back
Contact	<input type="text"/>	<input type="checkbox"/> I ask for a written offer
Phone number	<input type="text"/>	
Fax number	<input type="text"/>	
E-Mail	<input type="text"/>	

TRANSFER SYSTEM TSG

INQUIRY SUB-ENCLOSURE TSG 200

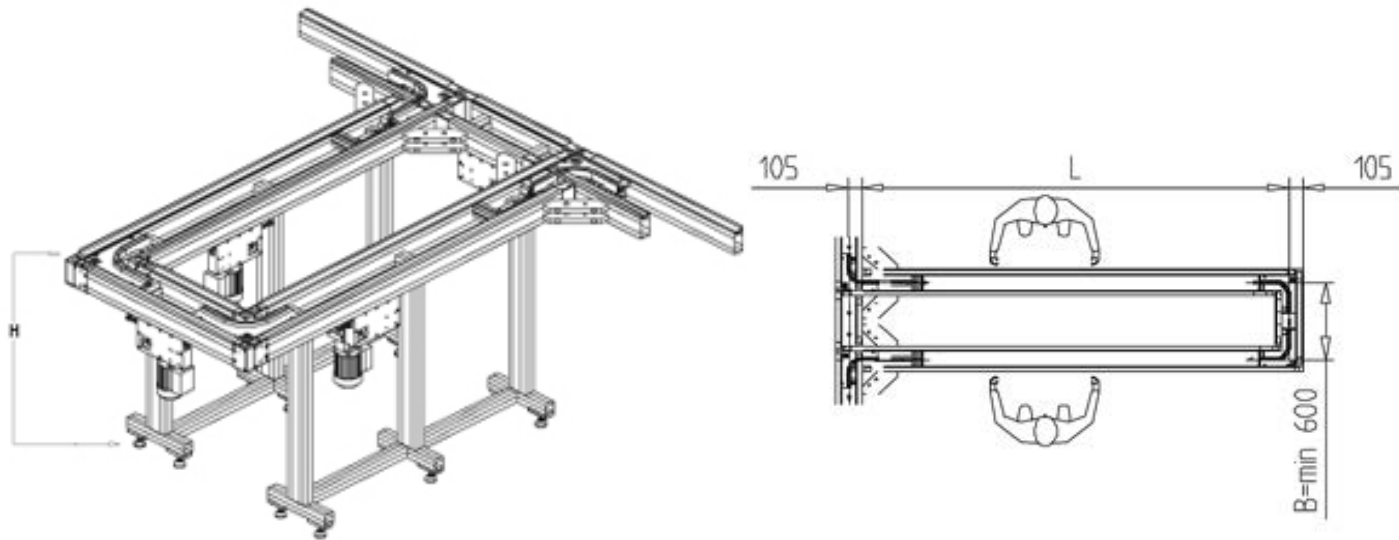

Measure L	<input type="text"/>	mm
Working height H (WT upper edge)	<input type="text"/>	mm
Number of stoppers	<input type="text"/>	Pcs.
Number of positioners	<input type="text"/>	Pcs.
Number of lifting stations	<input type="text"/>	
Transport direction	<input type="checkbox"/> right <input type="checkbox"/> left	
Speed	<input type="text"/>	m/min.
Frequency converter	<input type="checkbox"/> yes <input type="checkbox"/> no	
Control	<input type="text"/>	
Number of sensors	<input type="text"/>	Pcs.
Number of workpiece carriers	<input type="text"/>	Pcs.

Contact details

Company	<input type="text"/>	<input type="checkbox"/> Please call me back
Contact	<input type="text"/>	<input type="checkbox"/> I ask for a written offer
Phone number	<input type="text"/>	
Fax number	<input type="text"/>	
E-Mail	<input type="text"/>	

BASIC TRACK

Part no.

43.0020/0

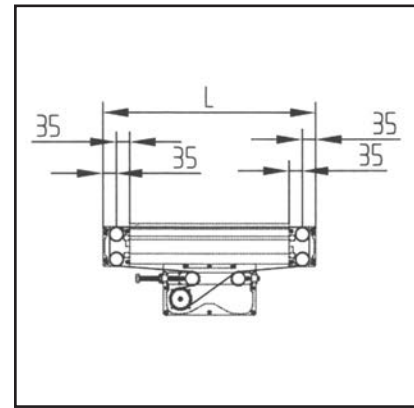
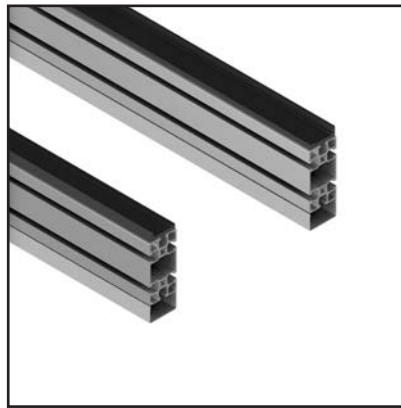
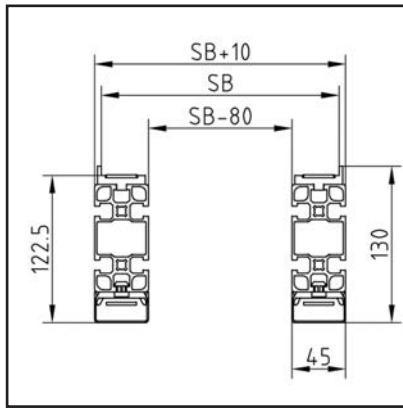

TECHN. DATA / ITEMS SUPPLIED

- $I_x = 112.823 \text{ cm}^4$
- $I_y = 28.526 \text{ cm}^4$
- Profile 45 x 90F, anodized, E6/EV1
- Sliding strip made of PE, black, extremely abrasion resistant, L max: 2 m
- Cover profile for belt return with clip fastening
- Timing belt for drive
- Spreading width (SB): universal
- Route length = L-140 mm
- Track length min. 270 mm
- Track length min. 4000 mm

APPLICATIONS

- Implementation in all TSG transfer systems
- Max. track load depending on drive concept (see table Technical data)
- When exceeding the total load per section, please divide into several sections
- Timing belt length calculation formula:
Length of timing belt = $(L - 70) \times 2 + 473 \text{ mm}$
round up to 5 mm pitch

ASSEMBLY

- Screw the basic distance with supports
- After attachment of drive unit, diversions and timing belts, clip cover profile onto underside of profile
- Free profile grooves for attaching stoppers, sensors, switches, ect. With standard screws

BASIC MODULE 200

Part no.

43.0010/0

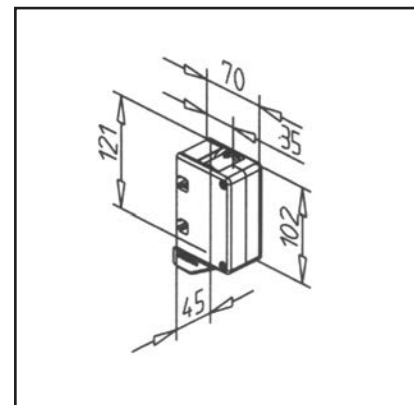
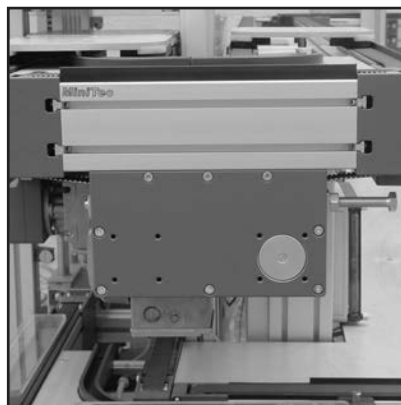
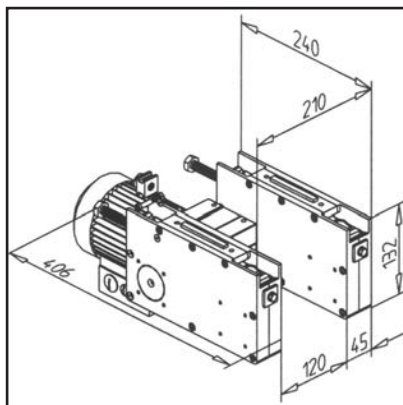

TECHN. DATA / ITEMS SUPPLIED

- Drive unit with integrated belt tensioners comprising 2 belt drives with connecting shaft and 1 motor
- 4 timing belt reverse units for 25 T5 timing belt
- Track width: 200 mm

APPLICATIONS

- All TSG transfer systems with 25 T5 timing belt

ASSEMBLY

- Remove drive unit cover
- Screw drive unit securely with attachment set centrally on the bottom of the basic line
- Remove covers from reverse units
- Fasten reverse units with profile connectors at the ends of the base section
- Insert timing belt
- Install cover of drive units and reverse units
- Tighten the timing belt
- Easy re-tightening of timing belt at drive unit, without prior disassembly, also during operation

BASIC MODULE VARIABLE

Part no.

43.0011/0

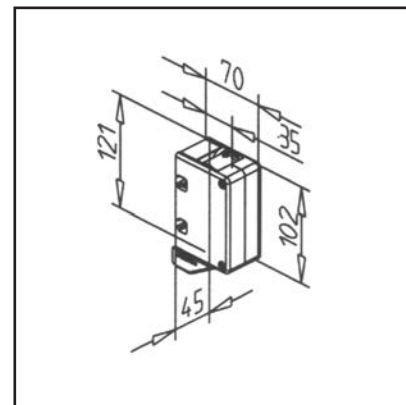
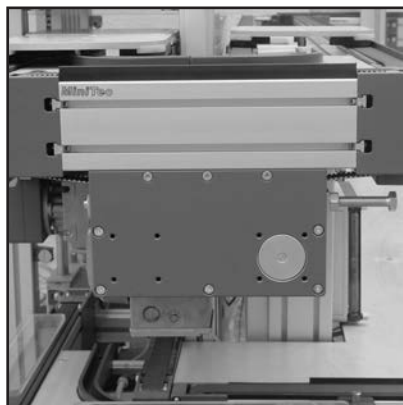
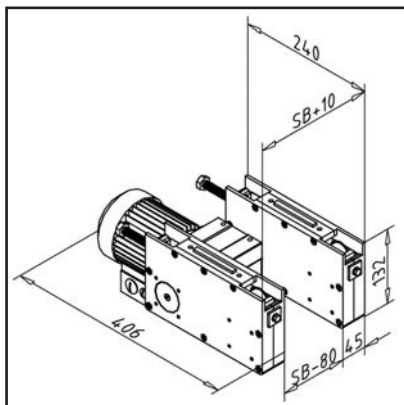

TECHN. DATA / ITEMS SUPPLIED

- Drive unit with integrated belt tensioners comprising 2 belt drives with connecting shaft and 1 motor
- 4 timing belt reverse units for 25 T5 timing belt
- **Please specify the desired track width**

APPLICATIONS

- Transfer systems with deviant track width
- Width according to dimension L of basic line

ASSEMBLY

- Remove drive unit cover
- Screw drive unit securely with attachment set centrally on the bottom of the basic line
- Remove covers from reverse units
- Fasten reverse units with profile connectors at the ends of the base section
- Insert timing belt
- Install cover of drive units and reverse units
- Tighten the timing belt
- Easy re-tightening of timing belt at drive unit, without prior disassembly, also during operation
- Base frames, corner transfer and workpiece carrier upon request

BASE FRAME 200

Part no.

43.0030/0

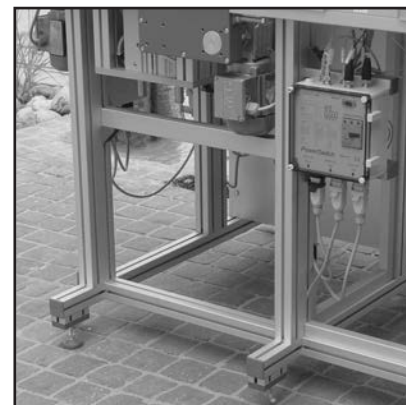
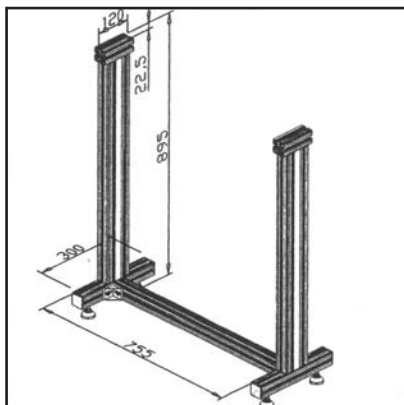

TECHN. DATA / ITEMS SUPPLIED

- Aluminium, anodized E6/EV1
- Profile 45 x 45 F, completely assembled
- with fastening material for connecting to the base section
- 4 height adjustable feet
- Create longer lines with additional add-on supports
- Height 895 mm for standard working height of 950 mm
- Length 755 mm for line length of 1000 mm

APPLICATIONS

- Subframe for transfer system with standard work height of 950 mm
- Suitable for track width 200

ASSEMBLY

- Install transverse profiles with mounting brackets on the lower profile groove between the base section.
- Secure to floor with angles and floor anchors

EXPANDED BASE FRAME 200

Part no.

43.0040/0

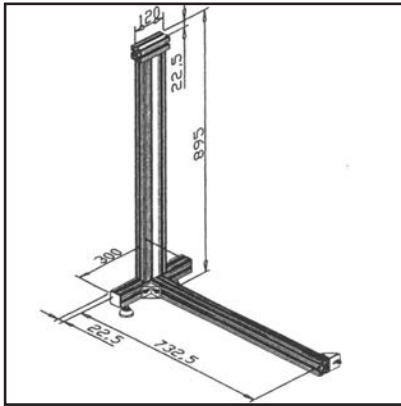

TECHN. DATA / ITEMS SUPPLIED

- Aluminium, anodized E6/EV1
- Profile 45 x 45 F, completely assembled
- with fixation material for the connection with the base track and base support
- 2 adjustable feet
- Height 895 mm for standard working height of 950 mm

APPLICATIONS

- Substructure for transfer systems with standard working height of 950 mm
- Suitable for track width 200

ASSEMBLY

- Create lengthwise connection with base support
- Install transverse profile L = 120 mm with mounting angles on the lower profile groove between the base section
- Secure to floor with angles and floor anchors

CURVE 90° RIGHT / LEFT

Part no.

43.0050/0

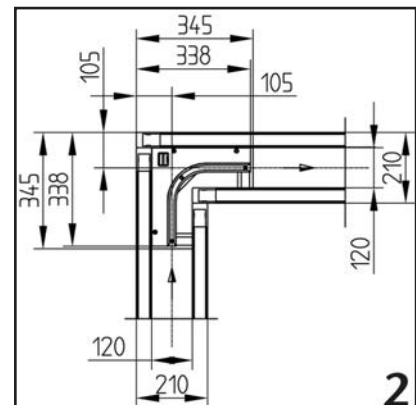
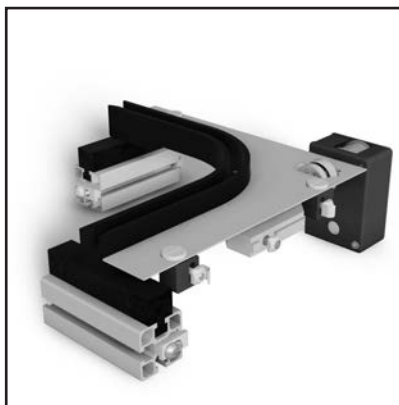
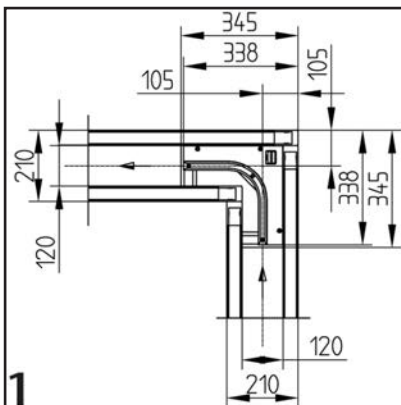

TECHN. DATA / ITEMS SUPPLIED

- 1 Traverse
- Friction wheel with drive roller
- Curved guide made of PE
- Cover AL
- Fastening material

APPLICATIONS

- No separation before curve required
- Production of compact transfer systems, auxiliary connections or combined system concepts
- Suitable for track width 200

ASSEMBLY

- Place the friction wheel on the reverse unit (on the inlet side in the conveying direction)
- Assemble corners with curvilinear guide
- Screw on cover
- Through appropriate assembly design 1, alternative design 2 can be produced

CURVE 200 - 180° RIGHT

Part no.

43.0060/0

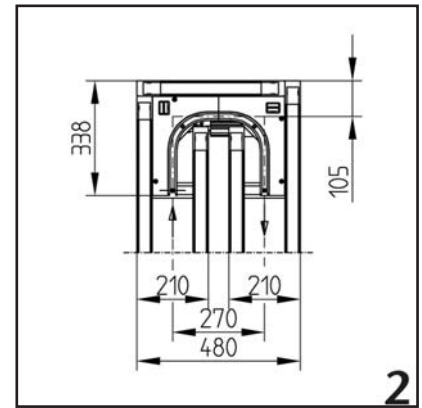
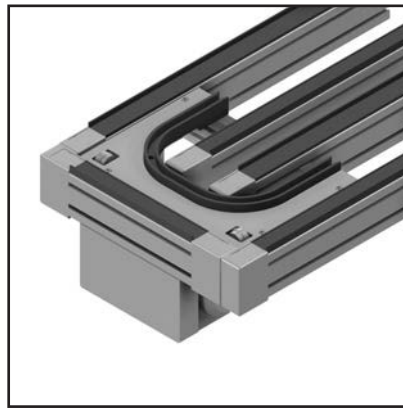
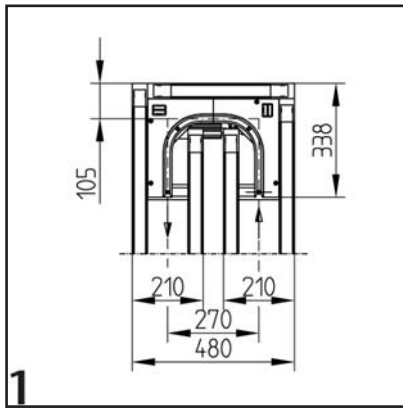
**TECHN. DATA / ITEMS SUPPLIED**

- 1 transverse section with drive module, motor mounted
- Beams with curve guidance made of PE
- 2-part cover
- Friction wheel with drive roller
- Fastening material
- Weight = 13.860 kg/piece

APPLICATIONS

- No separation before curve required
- Production of compact transfer systems, auxiliary connections or combined system concepts
- Suitable for track width 200

ASSEMBLY

- Place the friction wheel on the reverse unit (on the inlet side in the conveying direction)
- Assemble corners with curvilinear guide
- Install transverse transport with assembled drive module
- Screw on cover
- Through appropriate assembly design 1, alternative design 2 can be produced

STOPPER

Part no.

43.1510/0

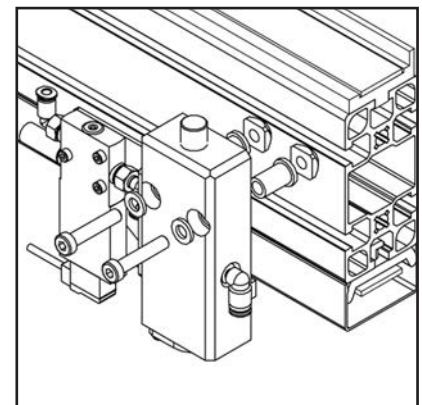
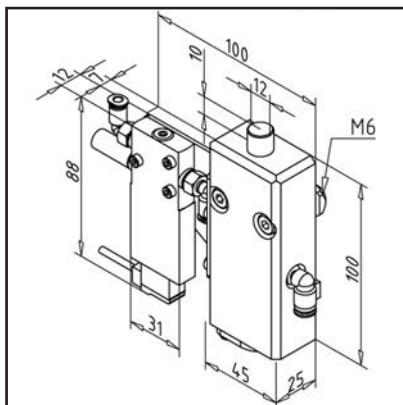
**TECHN. DATA / ITEMS SUPPLIED**

- Pneumatically actuated
- Housing PE, black
- Fixing pins \varnothing 12 mm made of stainless steel, hardened
- Prepared for connection to internal air supply
- Cylinder and valves integrated
- Fastening kit
- Weight = 0.482 kg/piece

APPLICATIONS

- Separation of workpiece trays before infeed and discharge, lift or lift stations
- Control of priorities in WT flow

ASSEMBLY

- Tighten on the inner side of the conveyor line at the top profile groove
- Make connection to air supply
- Position can be adjusted horizontally
- Separation of tray's by combination of 2 stoppers

PROXIMITY SWITCH

Part no.

43.0090/0

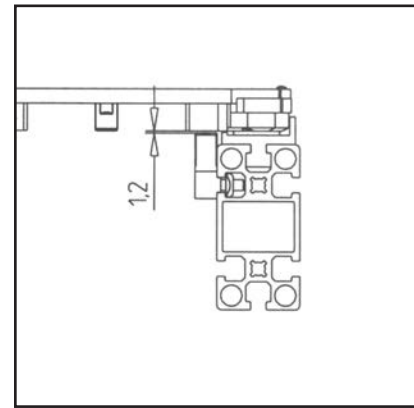
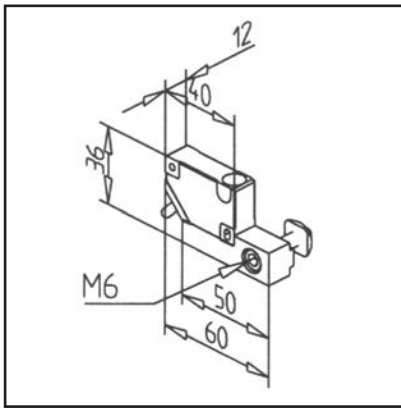

TECHN. DATA / ITEMS SUPPLIED

- Inductive proximity switch PNP type "NO contact"
- Operating distance 4 mm
- Cubic, plastic PBTp
- Operating voltage (V) Oct 36 DC
- Continuous current load 250 mA
- Protection type IP 67
- Fastening kit
- Weight = 0.047 kg/piece

APPLICATIONS

- Switching operations
- Control of system in front of locks, lifting stations and stoppers

ASSEMBLY

- Tighten on the inner side of the conveyor line at the top profile groove
- Position can be adjusted horizontally

OUTWARD TRANSFER 200

Part no.

43.0073/0

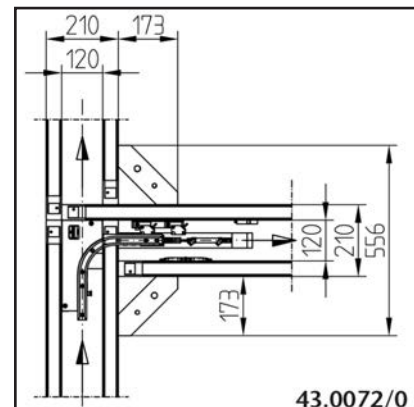
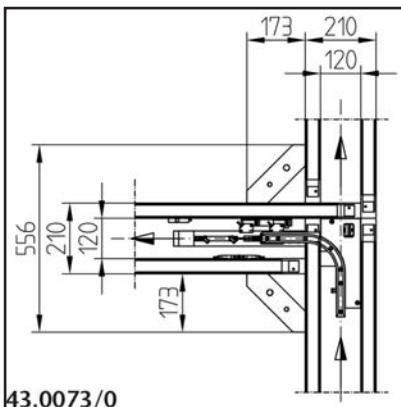

43.0073/0

43.0072/0

TECHN. DATA / ITEMS SUPPLIED

- Pneumatically actuated
- Carrier profile 45 x 90
- WT-guide 2 parts, PE
- Cover PE
- Friction wheel with drive roller
- 2 Pneumatic cylinders
- 4 beams
- Fastening material

APPLICATIONS

- Deflect WT's from secondary sections into the base circuit
- Separation of work procedures from machine cycle
- Inserting further processing stations
- Forming storage units
- With active outward transfer, the WT is swung out at 90° from the track in transverse transport. The orientation of the WT is not changed.
- If the chute is inactive, the WT remains in the basic circuit
- Status query of the chute via the sensor
- Suitable for track width 200

ASSEMBLY

- Outflow on the left **part no. 43.0073/0**
- Outflow on the right **part no. 43.0072/0**
- Mount friction wheel on pulley (in conveyor direction, at the longer conveyor side)
- Install pneumatic cylinder
- Install the guide curve
- Screw on cover
- Connect and align the transverse transport with beams
- Connect pneumatic cylinder to compressed air supply

INWARD TRANSFER 200

Part no.

43.0071/0

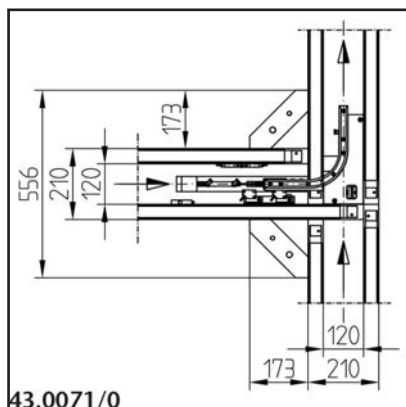

43.0071/0

TECHN. DATA / ITEMS SUPPLIED

- Pneumatically actuated
- Carrier profile 45 x 90
- WT-guide 2 parts, PE
- Cover PE
- Friction wheel with drive roller
- 2 Pneumatic cylinders
- 4 beams
- Fastening material

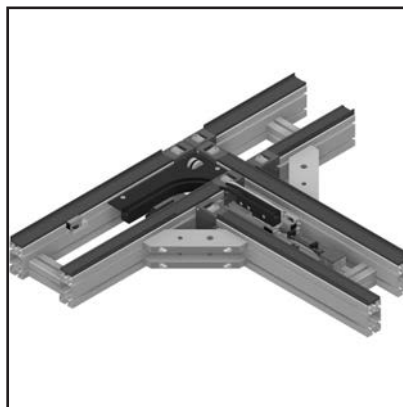
**APPLICATIONS**

- Return WT's from secondary sections into the base circuit
- Separation of work procedures from machine cycle
- Inserting further processing stations
- Forming storage units
- When the inlet is active, the WT is deflected from the secondary section into the base circuit
- The orientation of the WT is not changed. Status request of transfer with sensor
- Suitable for track width 200

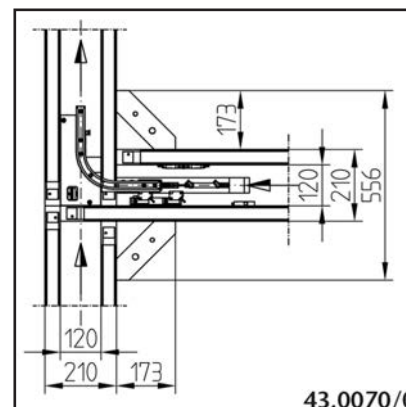

43.0070/0

ASSEMBLY

- Inward transfer right **part no. 43.0071/0**
- Inward transfer left **part no. 43.0070/0**
- Mount friction wheel on pulley (in conveyor direction, at the longer conveyor side)
- Install pneumatic cylinder
- Install the guide curve
- Screw on cover
- Connect and align the transverse transport with beams
- Connect pneumatic cylinder to compressed air supply

WORKPIECE TRAY 200

Part no.

43.1000/0

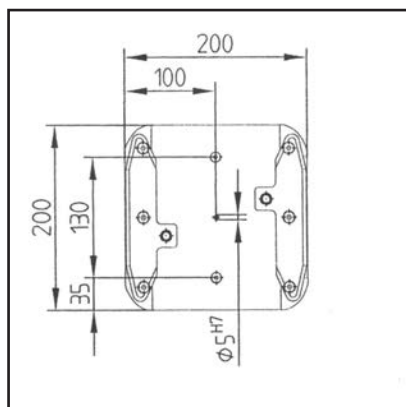
**TECHN. DATA / ITEMS SUPPLIED**

- Carrier plate Al, progressed on all sides and anodized with centering hole 5H7
- 4 positioning pins, st
- Sliding shoe made of extremely abrasion-resistant PE, with integrated stop for brake
- 2 damping pins, St, for proximity switches
- dimensions 200 x 200 mm
- Max. load capacity: 100 N
- Weight = 1.152 kg/piece

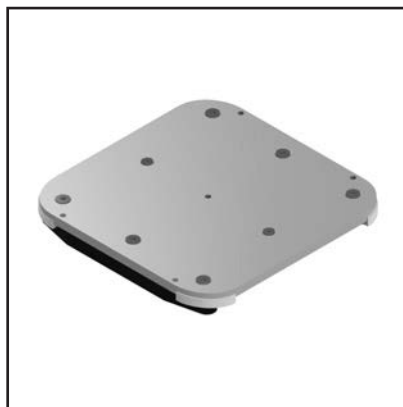
**APPLICATIONS**

- Recording of workpieces, devices, identification and data storage systems

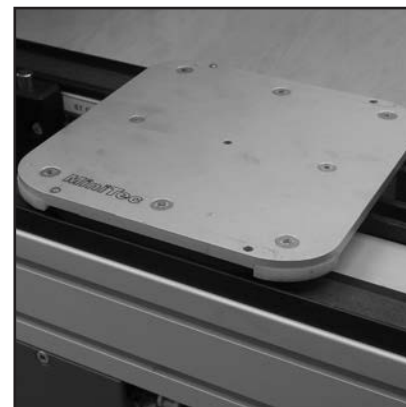
**ASSEMBLY**

- Standard-WTs are delivered without holder holes
- Mounting holes for workpieces, devices or identification systems are manufactured according to customer specifications

POSITIONER

Part no. 43.0110/0

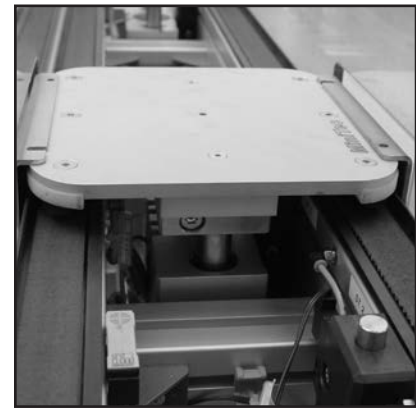
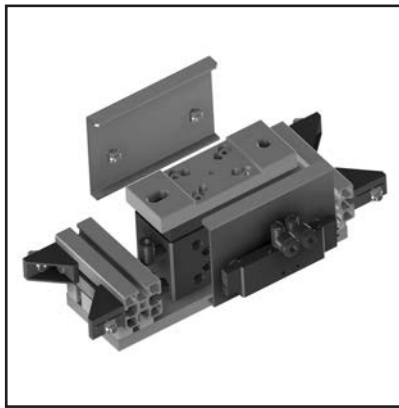
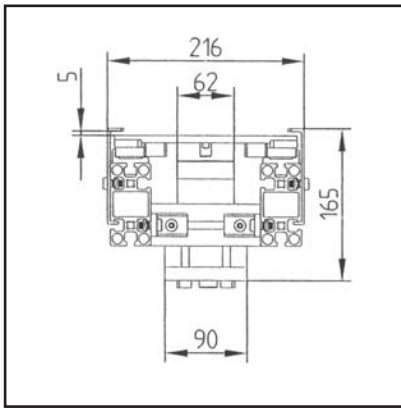

TECHN. DATA / ITEMS SUPPLIED

APPLICATIONS

ASSEMBLY

- Ready-to-install module with double-acting pneumatic cylinder and valve
- WT mount
- 2 override strips, galvanized steel
- Max. load capacity: 100 Kg
- Positioning accuracy: $\pm 0,03$ mm
- Lifting height over conveyor 5 mm
- Weight = 7.693 kg/piece

- Exact positioning of workpieces on the work-piece tray for processing or inspection

- Fasten lifting unit to profile section with supplied hardware
- Screw the override strips on the outside of the track, align exactly with the positioner
- Make connection to internal compressed air supply
- Suitable stopper **part no. 43.1510/0** and proximity switch **part no. 43.0090/0**

LIFT STATION 200

Part no. 43.0100/0

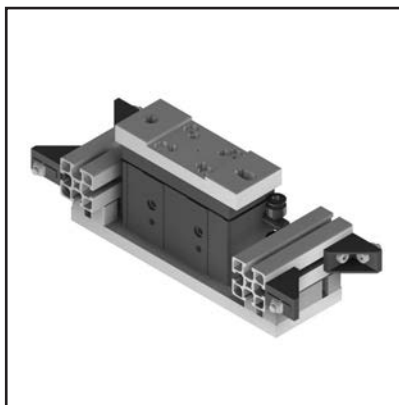
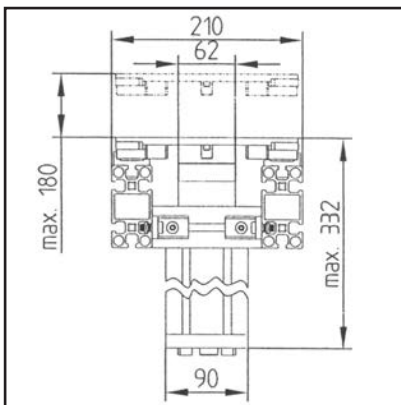

TECHN. DATA / ITEMS SUPPLIED

APPLICATIONS

ASSEMBLY

- Ready-to-install module with double-acting pneumatic cylinder and valve
- WT mount
- Lift height: Can be set from 5 mm to 180 mm above belt
- Weight = 6.900 kg/piece

- Exact positioning of workpieces on the work-piece tray for processing or inspection

- Fasten lifting station to profile section with supplied hardware
- Make connection to internal compressed air supply
- Suitable stopper **part no. 43.1510/0** and proximity switch **part no. 43.0090/0**

LIFT STATION

Part no. 43.0080/0

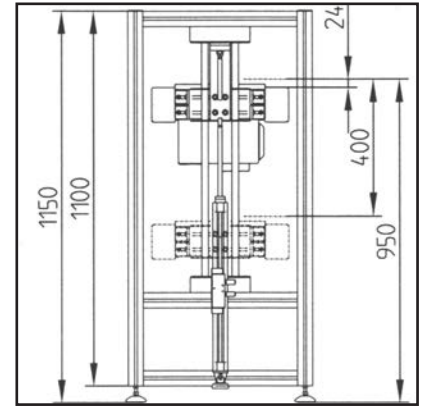
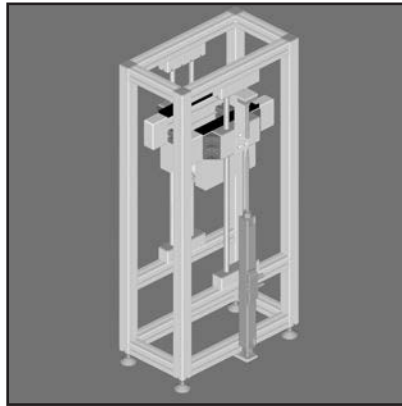
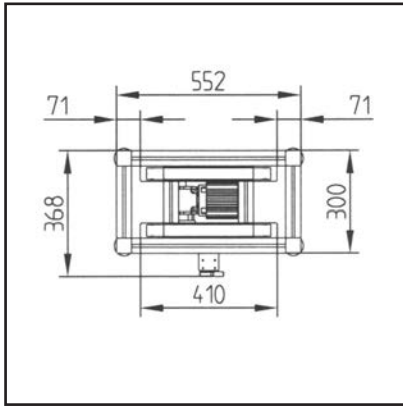

TECHN. DATA / ITEMS SUPPLIED

- Aluminium
- Ready assembled module according to customer specification
- Frame structure from construction profiles 45 x 45
- installed on lifting carriages, driven double-track line
- Lift carriage with dual-functioning pneumatic cylinder
- sturdy guidance of the lifting carriage with precision shafts Ø 20 mm and linear units LB series
- Lift height variable according to customer specification
- Max. load capacity: 480 N

APPLICATIONS

- Production of conveyor rollers in any length for roller tracks with or without drive

ASSEMBLY

- Align lift station with transport levels

TIMING BELT

Part no. 43.1411/0

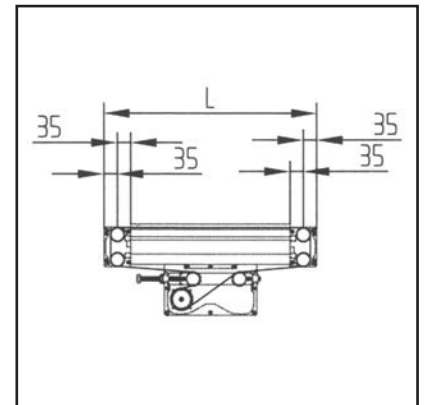
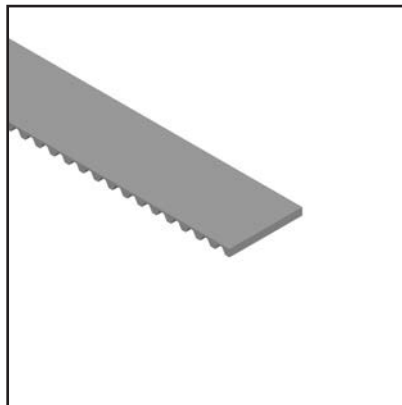
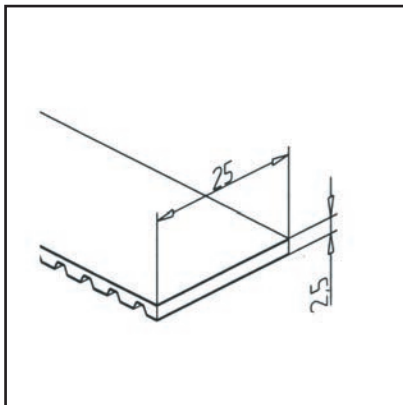

TECHN. DATA / ITEMS SUPPLIED

- Endless belts, reinforced with steel inlay
- Covered with plastic fabric on both sides to improve sliding characteristics and reduce friction
- Colour: green
- **When ordering spare parts, specify total length**
- Weight = 0.055 kg/m

APPLICATIONS

- All transfer systems TSG
- Timing belt length calculation formula:
Length of timing belt = $(L - 70) \times 2 + 473$ mm round up to 5 mm pitch

ASSEMBLY

- Remove belt cover (clip lock)
- Remove cover of drive unit and timing belt reverse units
- Insert belt
- Mount cover and belt cover
- Tighten the timing belt

SEGMENTED CHAIN CONVEYOR GKF

FROM ICE COLD TO HOT

The segmented chain conveyor GKF has already proven its reliability in numerous applications. Due to the different requirements, the series has been expanded to include field-tested components. At the same time, the highest level of energy efficiency and utmost flexibility were accorded great importance by our proven modular design.

Like all MiniTec constructions, the GKF series is based on the proven MiniTec profile system. The new route profile was constructed according to the same principles, so that the modular system was fully retained. All components are suitable for extensions, attachments or any necessary protective devices. The new conveyor system can be perfectly combined with the proven solutions of MiniTec in the areas of material handling, image processing, labeling, workplace design.

The link chain made of plastic or corrosion-resistant stainless steel allows straightforward and curved horizontal and vertical movements.

The flexible routing allows space-saving constructions, whereby vertical curve guidance or lifting devices allow the use in several levels.

Application examples segmented chain conveyor GKF

Transport in test facilities. Combination of individual and re-packaging systems, labeling, shipping logistics, connection of workstations, assembly lines

Car parts

Filters, gears, fuel pumps, ball bearings, castings, lamps

Cosmetics + Pharma

Pharmaceutical packs, gauze bandages, paper rolls, spray cans, body care products, shampoo, toothpaste and toothbrushes, dental instruments.

Foods

Trays with fruit, beverage cans, food cans, packaged textiles, coffee cans, coffee packs, plastic bottles, yogurt, animal feed

Electronics

Electronics components, audio and video equipment, equipment, batteries, mobile phones, computer parts,

Note

Not suitable for bulk material!

System selection 90 to 314 mm

The systems are available with 8 different plastic chains made of modified acetal and 3 stainless steel versions 1.4016.

Chain pins on all chains made of stainless steel 1.4305

Chain pitch uniform: 38,1 mm,

The almost gap-free surface also allows the transport of small components!

- Product width 0-428 mm
- Maximum conveyed weight during horizontal transport 10 kg/m
- Maximum transported goods weight for vertical transport 2 kg/m
- Maximum load on the conveyor 150 kg
- Max. straight line of the conveyor line 40 m

HOLISTIC SOLUTIONS

The system is available in assemblies for self-assembly, as well as a ready-to-use system. On request, we take over the complete planning and installation, as well as the commissioning in your company. Our services also include the ergonomic design of workplaces with material and information provision.

SEGMENTED CHAIN CONVEYOR GKF

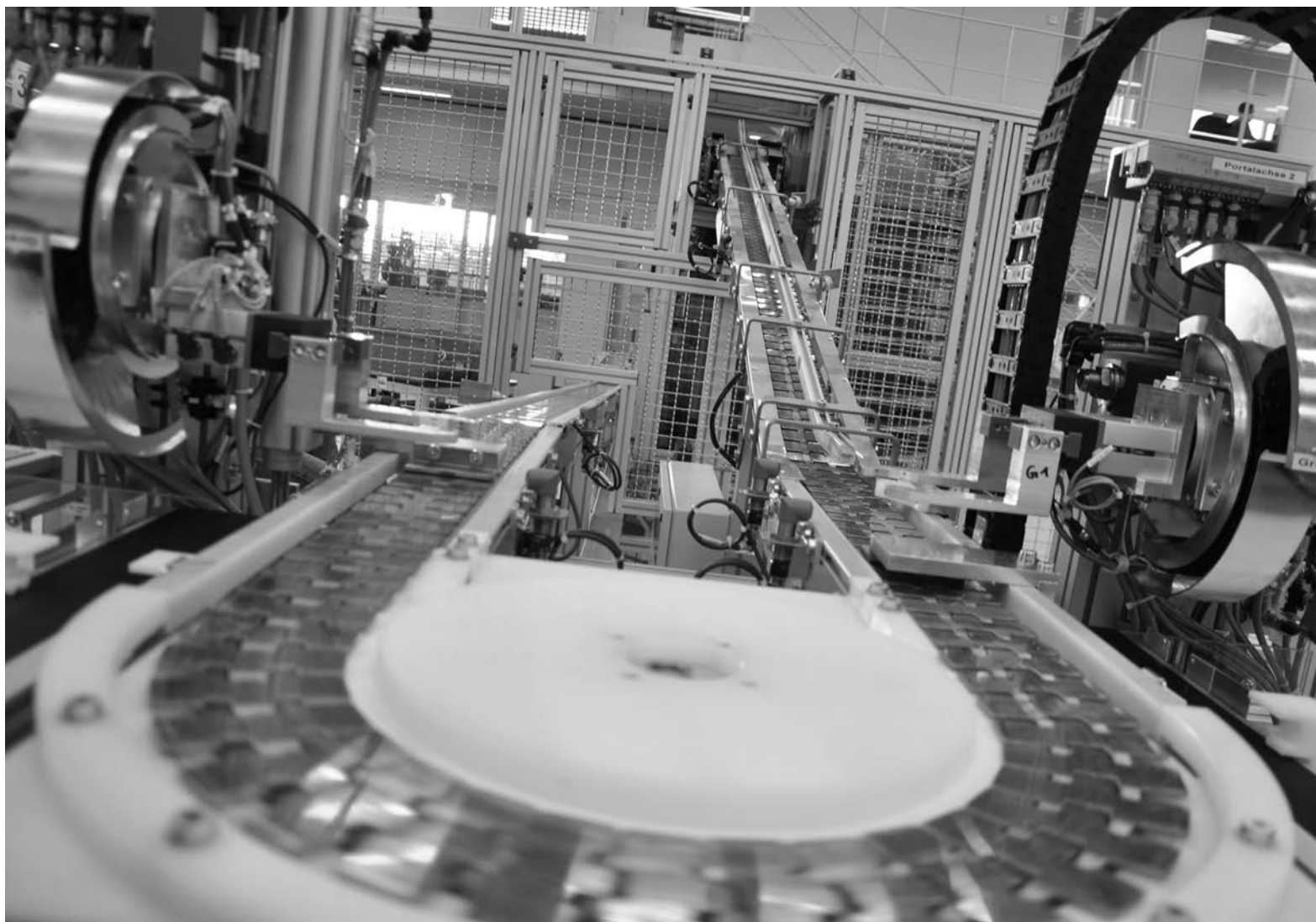

Depending on conveyed material, routing and chain, the system is suitable for high conveying speeds of up to 30 m / min. All motors used are provided with overload protection. Optionally, variable frequency drives are available.

■ Temperature limits

- Plastic chain (dry) -20°C to +80°C
- Plastic chain (wet) 0 ° C to + 60 ° C
- Stainless steel chain -3 ° C to +130 ° C

All chains are suitable for direct transport of products or pallet transport.

For reasons of energy savings and lower maintenance intensity, we recommend the use of cam wheels instead of horizontal arches. Cam wheels are available with a minimum radius of 200 mm.

Noise development as a function of the conveying speed, measured according to DIN 45 635 T1 on the motor side

	m/min	dB-A
VA-Chain	10	57,3
	30	73,2
Acetal Chain	10	62,8
	30	77,9

SEGMENTED CHAIN CONVEYOR GKF

APPLICATION EXAMPLES



Transportation of coffee doses below hall roof

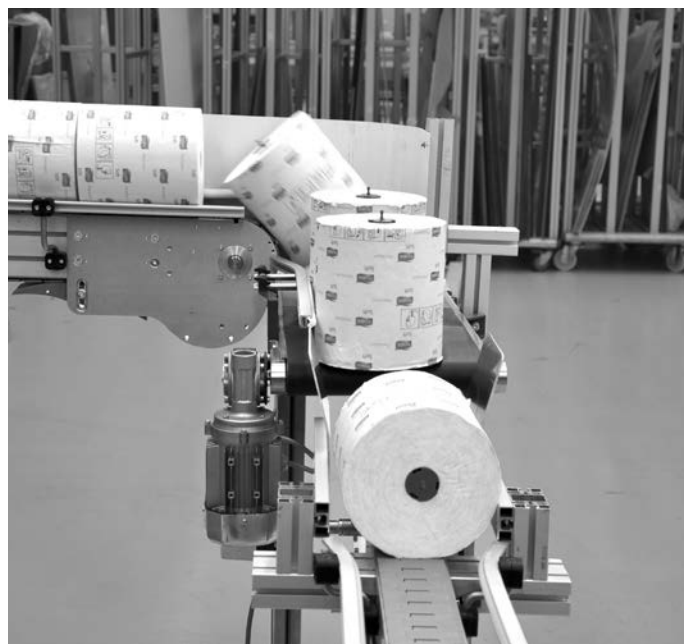

Transport and packaging of hygiene towels



Loading and unloading of lathes



Surface inspection of car parts

SEGMENTED CHAIN CONVEYOR GKF

INQUIRYGKF

Basic dimensions

Center distance A mm
 according to Layout see other attached seperately

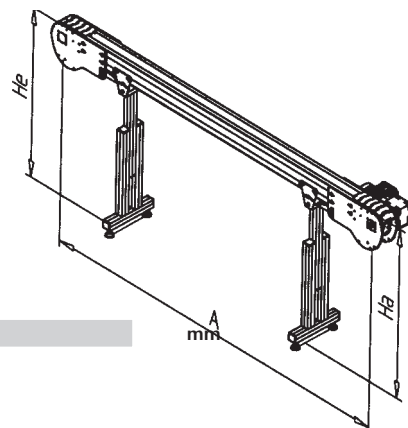

Operating conditions

Conveyed
 Dimensions W x L x H
 Units weight kg
 Total load on tape kg
 Temperature conveyed °C
 Congestion area

Subconstruction

Inlet height He mm
 Discharge height Ha mm
 Number of pillars Pcs.
 Pillars height adjustable from mm to mm
 Lateral guiding one-sided both-sided
 Floor assembly angel Part no. 21.1112/0
 High performance anchor 12 Part no. 21.1115/0
 Roll Part no.
 Stand Part no.

Options

Chain type Part no.

Drive

Engine location right left
 Speed m/min.
 Speed adjustable from m/min. to m/min.

Other / Layout



Contact details

Company Please call me back
 Contact I ask for a written offer
 Phone number
 Fax number
 E-Mail

FLEXIBLE ASSEMBLY LINES FMS

FMS is a flexible assembly system with workpiece carriers that are transported on accumulation roller chains, special belts or chains. Standardized modules for exact positioning, lifting or turning enable the very fast realization of complete assembly lines. Numerous installations at renowned automotive suppli-

ers have proven the reliability and economy of this system for years. The patented deflection technology reduces the control effort for the entire system to a minimum.

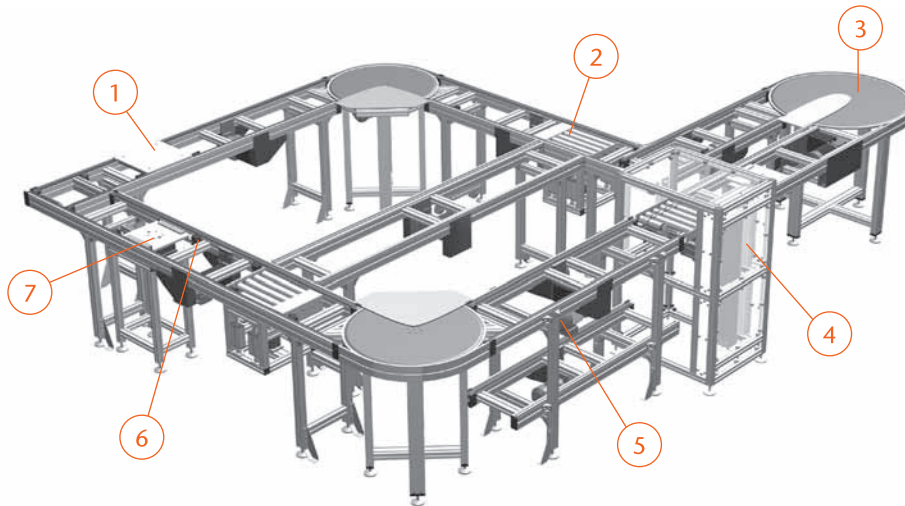

Modular assembly lines

- A complete “workpiece carrier” transport and positioning system, the fastest and most versatile form for process optimization in series production
- Thanks to the modular design and the structure and planning based on extruded aluminum profiles, complete systems are calculated in a very short time.

1. Workpiece carrier

- Precision-milled carrier plate
- Accessible from all sides, also from the bottom
- Anti-static polyethylene sliding strips
- Wheels in the corners reduce lateral friction and improve guiding properties
- Exact position detection with centering bushes

2. Cross transport

- Infeed and outfeed, direction change
- Very small space requirement
- Easy to integrate into the system

3. Turntable

- Without controls
- Virtually maintenance free
- Consistent orientation

4. Lifts up / down

- Vertical method with pneumatic or electric drive
- Precise guidance with linear units

5. Belt and chain conveyor

- Variations: double belt, chain drive or combination
- Suitable for accumulation mode
- Structure made of aluminum profiles
- Easy to expand and reusable

6. Separating

- Separator: with or without damping from 3 to 220 kg
- Switch holder: Various holders for M12 inductive proximity switches ensure the absence and passage control of the workpiece carriers

7. Lifting and positioning device

- Exact positioning of the WT for machining operations
- max. load 100 kg
- Optionally with turning device for changing direction

FLEXIBLE ASSEMBLY LINES FMS

INQUIRY FMS

Operating conditions

Dimensions W x L x H	<input type="text"/>	<input type="text"/>	<input type="text"/>	mm
Conveyed good B x L x H	<input type="text"/>	<input type="text"/>	<input type="text"/>	mm
Units weight	<input type="text"/>			kg
Temperature conveyed	<input type="text"/>			°C
	<input type="text"/>			m/min.
Main emphasis	<input type="checkbox"/> Centered	<input type="checkbox"/> Distance		mm
Workpiece receiving	<input type="checkbox"/> yes	<input type="checkbox"/> no		
WT base plate (L x W)	<input type="text"/>			mm
Number of WT	<input type="text"/>			Pcs.
Ambient temperature	<input type="text"/>			°C
Environmental conditions	<input type="text"/>			
Number of stoppers	<input type="text"/>			Pcs.
Number of positioners	<input type="text"/>			Pcs.
Number of sensors	<input type="text"/>			Pcs.

Other / Layout

Contact details

Company	<input type="text"/>	<input type="checkbox"/>	Please call me back
Contact	<input type="text"/>	<input type="checkbox"/>	I ask for a written offer
Phone number	<input type="text"/>		
Fax number	<input type="text"/>		
E-Mail	<input type="text"/>		

ROLLER CONVEYORS RMS

RMS is a pallet transfer system based on friction rollers and designed for very high loads. Among other things, transmissions, vehicle seats or engines are assembled on these systems. The workpiece carriers are moved over highly precise accumulator rollers, which are driven by means of a continuous tangential steel chain. The RMS specific workpiece carriers are guided by side-attached guide rollers into the line. Due to the

special shape of the workpiece carrier in combination with the patented DELTA -offset, the direction changes are realised with a minimum of control and drive effort. Special covers between the rollers make the transport system accessible for service work from the interior of the system.

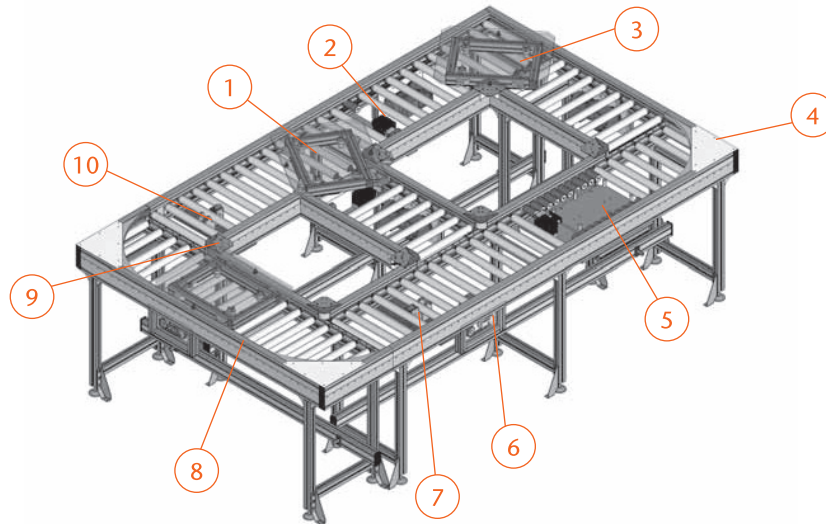
**System description**

- Flexible modular concept
- Precise rollers with adjustable friction
- Load per pallet holder: up to 250 kg
- Standard WT widths: 400 and 500 mm
- Transport speeds: up to 15m/min
- Ingeniously simple and patented bypass
- Newly developed robust workpiece carriers
- Delta" deflection system

1. Bypass

- Driven turnout for diversion from main to branch line

2. Rolles

- Steel pipe 3 mm
- Nitrided surface
- Adjustable friction

3. Workpiece carrier

- Base frame made of aluminium profile
- Sliding elements made of antistatic polyethylene
- Plate carriers according to customer specification

4. Deflection 90°

- WT deflection without additional drive

5. Stroke index unit

- Loadable up to 300 kg

6. Drive unit

- Reversible running direction
- Up to 9 m distance per drive
- Automatic chain tension

7. Separating stop

- Adjustable damping

8. Structure

- Anodised aluminium profile

9. Deflection system

- The "Delta" deflector system is a standardized and universally applicable system that enables all deflector variants in 3 versions:
- Delta 1 fixed for simple 90° deflections
- Delta 2 spring-mounted for inward transfer into a main or secondary route
- Delta 3 controllable and pneumatically operated for use at junctions with changing deflections

10. Hydraulically damped separating stops

- The specially developed separating stop allows the use of continuous rollers instead of stub rollers
- High flexibility through simple change of the installation position
- Translated with www.DeepL.com/Translator

ROLLER CONVEYORS RMS

INQUIRY RMS

Operating conditions

Dimensions W x L x H	<input type="text"/>	<input type="text"/>	<input type="text"/>	mm
Conveyed good B x L x H	<input type="text"/>	<input type="text"/>	<input type="text"/>	mm
Conveyor width	<input type="checkbox"/> 400mm	<input type="checkbox"/> 500mm	<input type="checkbox"/> different width	
Roller distance	<input type="checkbox"/> 120mm	<input type="checkbox"/> 180mm		
Head	<input type="text"/>			
Conveyor width	<input type="text"/>			
Conveyor speed	<input type="text"/>			m/min.
Main emphasis	<input type="checkbox"/> Centered	<input type="checkbox"/> Distance	<input type="text"/>	mm
Workpiece receiving	<input type="checkbox"/> yes	<input type="checkbox"/> no		
WT base plate (L x W)	<input type="text"/>			mm
Number of WT	<input type="text"/>			Pcs.
Ambient temperature	<input type="text"/>			°C
Environmental conditions	<input type="text"/>			
Number of stoppers	<input type="text"/>			Pcs.
Number of positioners	<input type="text"/>			Pcs.
Number of sensors	<input type="text"/>			Pcs.

Other / Layout

Contact details

Company	<input type="text"/>	<input type="checkbox"/>	Please call me back
Contact	<input type="text"/>	<input type="checkbox"/>	I ask for a written offer
Phone number	<input type="text"/>		
Fax number	<input type="text"/>		
E-Mail	<input type="text"/>		

PALLET CIRCULATION SYSTEMS UMS

The new UMS pallet circulation system is a very economical solution with minimum space requirements for the interlinking of processing machines, workplaces, handling devices or robot feeders. In the new system, the pallets are guided on precise linear guides with maintenance-free rollers. This ensures the exact positioning of the pallets and significantly reduces energy consumption. At the end of the conveyor section, the unloaded pallets are vertically deflected by a form-fitting gripper and transported back hanging on the underside. Pallet accumulation is possible both on the conveyor level and during return transport of the unloaded workpiece carriers (WT). The system even allows the use as overhead conveyor with pallet return on the top side. The pallets are driven by a continuously rotating central chain, the automatic chain tensioning ensures safe operation. The system is available in standard widths of 400, 500 and 1000 millimeters, other widths are also available on request. The maximum length of the individual pallets is 270 millimetres, whereby the pallets can be connected to each other. The maximum weight / pallet is 100 kilograms and the total load up to 1,200 kilograms. The positioning accuracy of ± 0.15 millimeters allows automatic loading and unloading of the pallets. At the insertion station, pallets can be added or removed from the system within minutes.

With one drive, conveyor distances of up to 100 meters with speeds of 6 m/min up to 12 m/min can be realized. The control effort for the UMS is very low, since no inward or outward transfer or redirection has to be programmed. MiniTec also relied on the high-quality standard components of its modular system for the development of the pallet circulation system UMS and thus enables its customers to work with a flexibly integrable conveyor system that is virtually maintenance-free and low-wear. MiniTec supports its customers with experienced engineers and technicians in the planning and implementation of entire conveyor systems as well as the adaptation of such systems.

- Max. length: 15 m
- Load on pallet: max. 100 kg
- Workpiece carrier width: 400 mm to 1000 mm
- Workpiece carrier length: 270 mm (several individual WTs can be interlinked)
- Speeds: 6, 9, 12 m/min
- Positioning accuracy of ± 0.15 mm
- Other dimensions, speed, weights on request

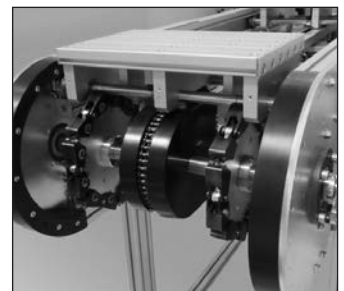
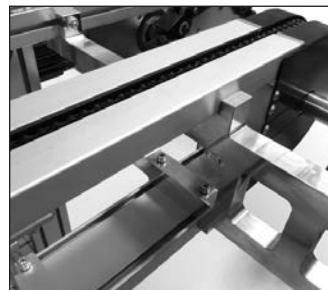
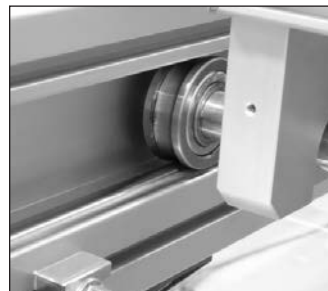
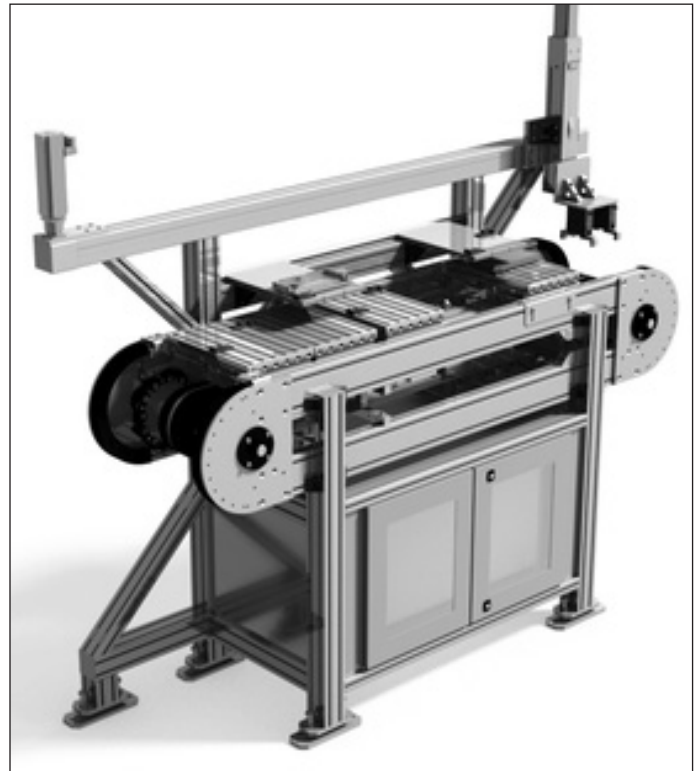



5.1

MACHINE PROTECTION

544



5.2

PROTECTION SYSTEM SAFE GUARD

550



5.3

NOISE PROTECTION

561

MACHINE PROTECTION

EXAMPLES



MACHINE PROTECTION

EXAMPLES



MACHINE PROTECTION

LIFTING DOORS

Completely assembled and prepared for final assembly. Aluminum profile construction with internal counterweights and a selection of different surface elements.

Table protection lifting door

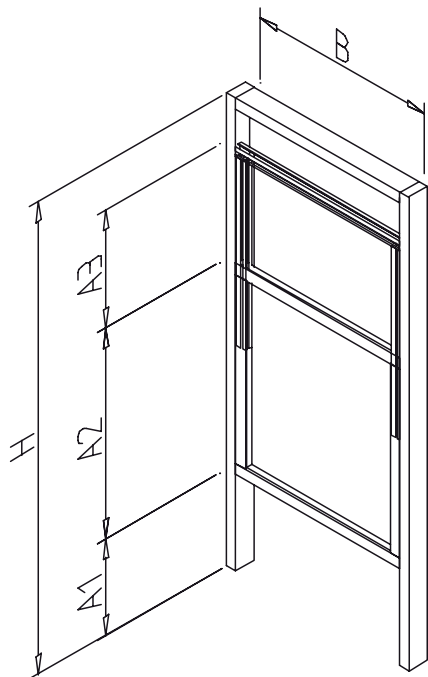

Machine protection lifting door

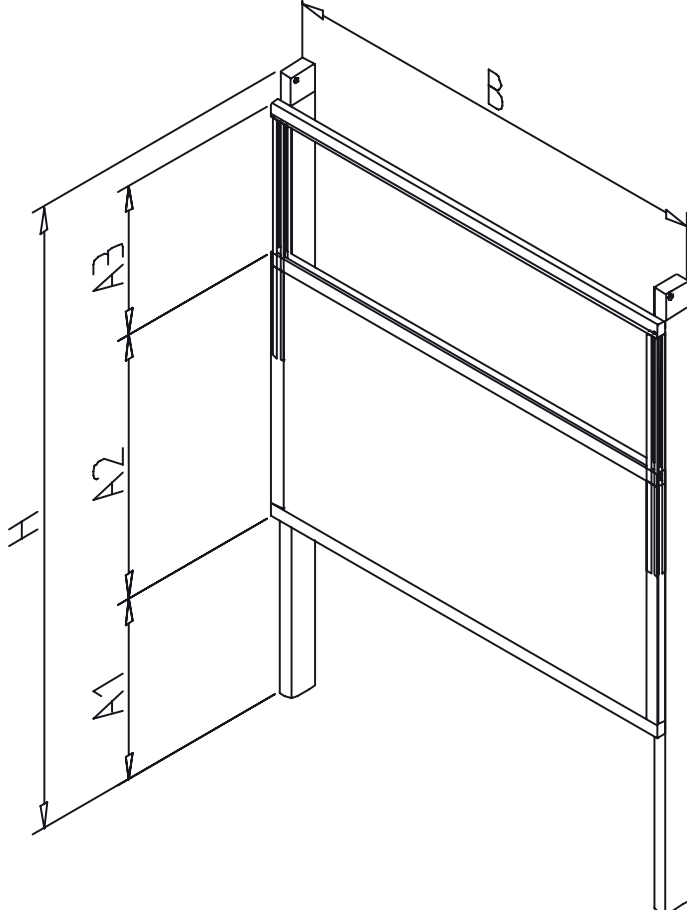

LIFTING DOOR WITH FALL PROTECTION

Part no.: 23.0200/0

Description

Modular lift door system with fall protection for manually operated doors up to a sash weight of 35 kg.

The lifting door is made individually from profiles of the 45 series.

With our lift doors you can choose between different surface elements - depending on the task and requirements.

In contrast to the standard MiniTec lifting doors, which are guided laterally via sliding elements in a groove, the lifting door with fall arrest is guided over two ground steel shafts.

To counterbalance weight, two counterweights serve as a bal-

ancer for the movable sash.

These counterweights run over a chain deflection in the central hollow chamber of a 90 x 90 L or 90 x 90 UL profile.

This MiniTec ensures an absolutely uniform and virtually power-free run.

Should a chain of the lift door break, the fall arrest will be activated, i.e. the lifting door is immediately braked by a clamping bush by the frictional resistance on the steel shaft.

Lifting door with fall protection	
Power unit	manually
Total width	Opening width + 180mm
Frame construction	Profile 45x45 & 90x90
Surface element selectable	Plastic, aluminum, aluminum composite, safety glass, polycarbonate and acrylic
Applications	Hand guard
Clear width	mm
External dimension B + 180	mm
Bearing dimension A1	mm
Height lifting frame	mm
Stroke A3	mm
Total height H	mm
Surface element	

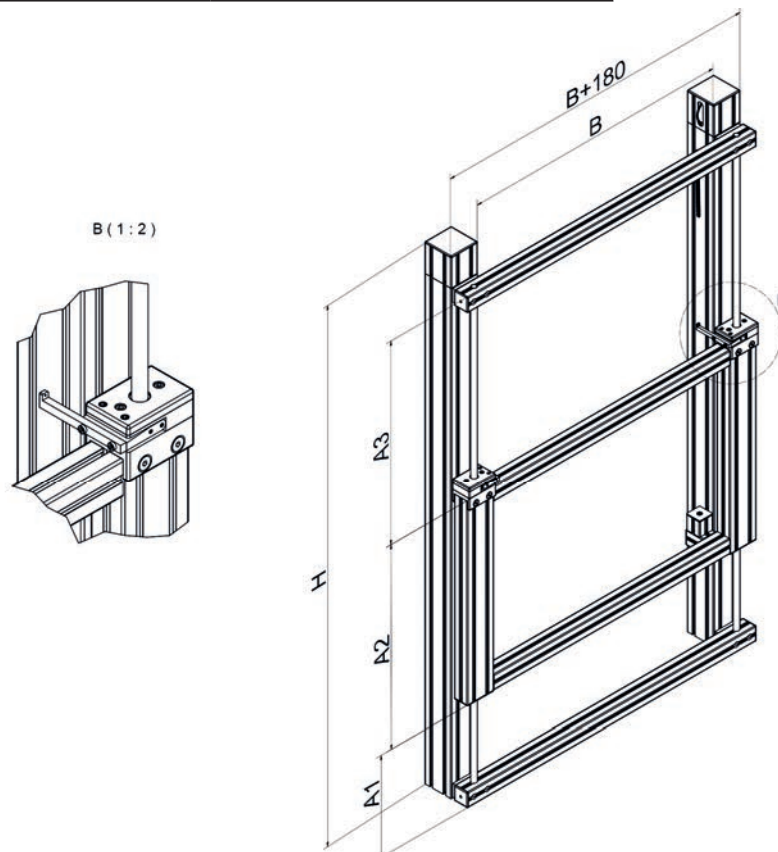

MACHINE PROTECTION

PROTECTION FIELDS

Protective and partition wall element with fixed frame

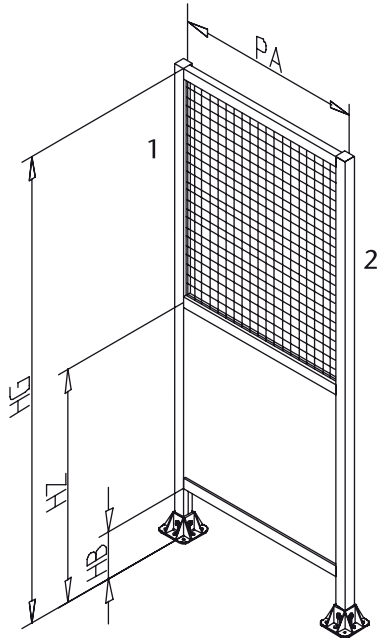

Items Supplied

- 1 Pillar
- 2 Crossbars
- 1 Surface element mounted:
- Wave grid, mesh size 40 mm, wire gauge 4 mm, galvanized

The profile column 2 is included in the delivery of the next field. For single installation order additional profile column.

Protective and partition wall element with removable frame

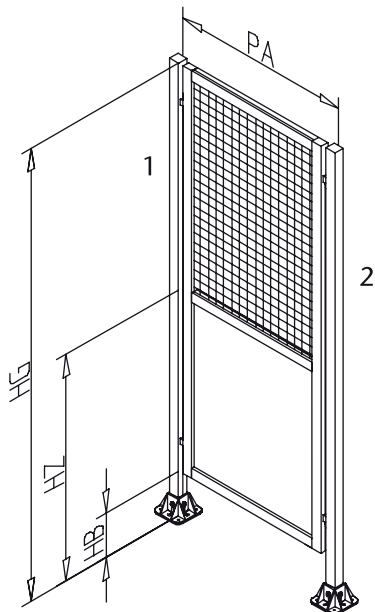

Items Supplied:

- 1 Protective field mounted: wave mesh, mesh size 40 mm, wire gauge 4 mm, galvanized
- 1 Profile column with floor mounting and 2 protective field suspensions

The profile column 2 is included in the delivery of the next field. For single installation order additional profile column.

MACHINE PROTECTION

INQUIRY LIFTING DOOR & PROTECTION FIELD

Lifting Door

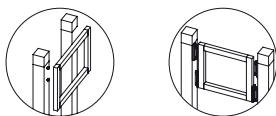

Lifting door arrangement	<input type="checkbox"/> outside	<input type="checkbox"/>
Lifting field width	<input type="text"/>	
Lifting field height A	<input type="text"/>	
Stroke A3	<input type="text"/>	
Rally A1	<input type="text"/>	
Operation	<input type="checkbox"/> hand	<input type="checkbox"/>
Surface element	Part no. <input type="text"/>	
Strokes per hour	<input type="text"/>	
Additional field fix	above <input type="checkbox"/> yes	<input type="checkbox"/>
	below <input type="checkbox"/> yes	<input type="checkbox"/>

inside	<input type="checkbox"/>
mm	<input type="text"/>
mm	<input type="text"/>
mm	<input type="text"/>
mm	<input type="text"/>
pneumatic	<input type="checkbox"/>
no	<input type="checkbox"/>
no	<input type="checkbox"/>

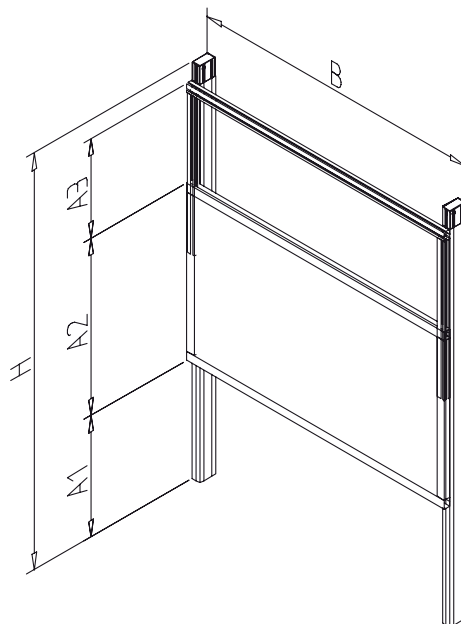

Protection field

Protection field frame	<input type="checkbox"/> firm	<input type="checkbox"/>
Total height HG	<input type="text"/>	
Ground clearance HB	<input type="text"/>	
Pole distance PA	<input type="text"/>	
Intermediate support	<input type="checkbox"/> yes	<input type="checkbox"/>
Height intermediate strut HZ	<input type="text"/>	
Surface element above	Part no. <input type="text"/>	
Surface element below	Part no. <input type="text"/>	
Foot	<input type="checkbox"/> Stand	<input type="checkbox"/> Base plate <input type="checkbox"/> without

Exchangeable frame	<input type="checkbox"/>
no	<input type="checkbox"/>

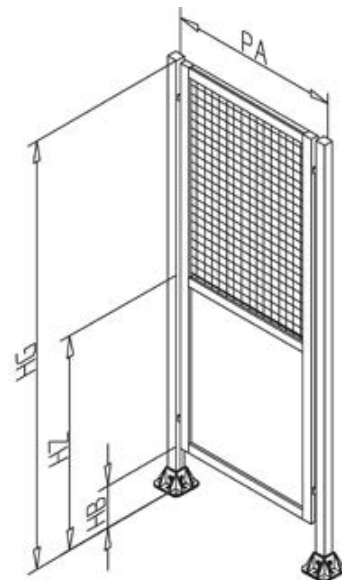

Contact details

Company	<input type="text"/>
Contact	<input type="text"/>
Phone number	<input type="text"/>
Fax number	<input type="text"/>
E-Mail	<input type="text"/>

<input type="checkbox"/>	Please call me back
<input type="checkbox"/>	I ask for a written offer

PROTECTION SYSTEM SAFE GUARD

PROTECTION SYSTEM SAFE GUARD SAFETY DISTANCE

SAFETY SYSTEMS

Individually arranged protection devices are a common field of application of the comprehensive MiniTec profile system. With our design software MiniTec CADmenu, separating protection systems can be designed and calculated in the shortest time. These are exactly adapted to customer requirements, with high demands on safety standards and optical effect. Our standardized modules are particularly cost-effective solutions, taking into account the current standards and the Machinery Directive. separating guards must prevent access to the source of danger and at the same time protect against ejected parts, moving machine parts or escaping liquids. The device must be designed in such a way that it cannot be removed without tools, but the design of the protective device must always be preceded by a risk assessment according to EN ISO 12100-1 by the system manufacturer.

Safety distances

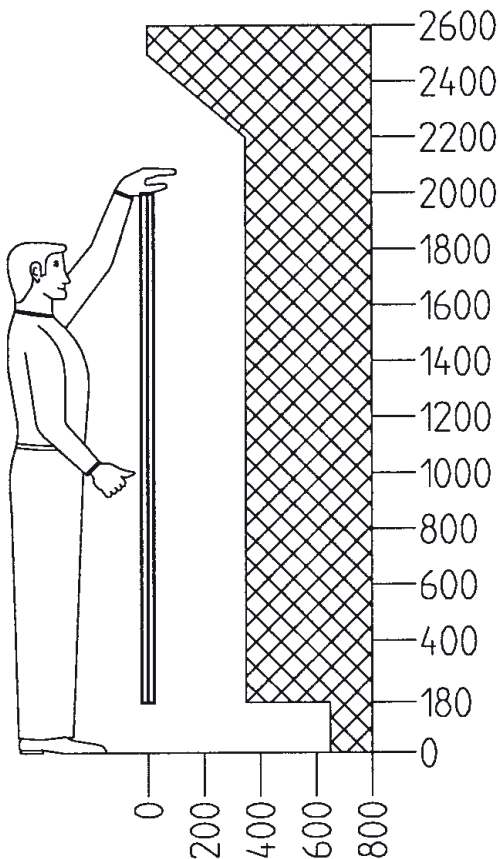

Passing over protective constructions - low risk

The required safety distances for the upper limbs are specified in DIN EN 13857.

Protective field

Height: 2000 mm

Distance to danger zone: 350 mm
The safety distances for the lower limb are specified in EN 811. The safety distance to the source of danger depends on the ground clearance of the protective field.

Protective field

Ground clearance: 180 mm

Distance to danger area: 665 mm

PROTECTION SYSTEM SAFE GUARD

LOADABILITY GRID SYSTEM

Load-bearing capacity

The load capacity of the standard protective fields was determined in empirical tests. In the middle of the field, a plate 200x200 mm was loaded statically until the wavy grid is pressed out of the clamping profile. The specified values apply to protective fields made of clamping profile 32x32 with corrugated grid, galvanized steel, 40x40x4 mm.

Field height HS mm	Field size B mm	Weight F N
1820	500	1200
1820	750	1200
1820	1000	1000
1820	1250	1000
1820	1500	1200
1820	1750	1100
1820	2000	1000

The dynamic load capacity of the protective fields was tested in pendulum impact tests with a mass of 100 kg by TÜV Saarland. All required parameters of the EC Machinery Directive 2006/42 / EC have been met.

Grid system

The standardised Safe Guard system is an especially economic and quick solution for most applications. Individual heights, field sizes, special designs for noise protection or splash water protection and optional fastening types are available for special tasks.



PROTECTION SYSTEM SAFE GUARD

ASSEMBLY EXAMPLE

Field widths

Groove center distance of posts „B”

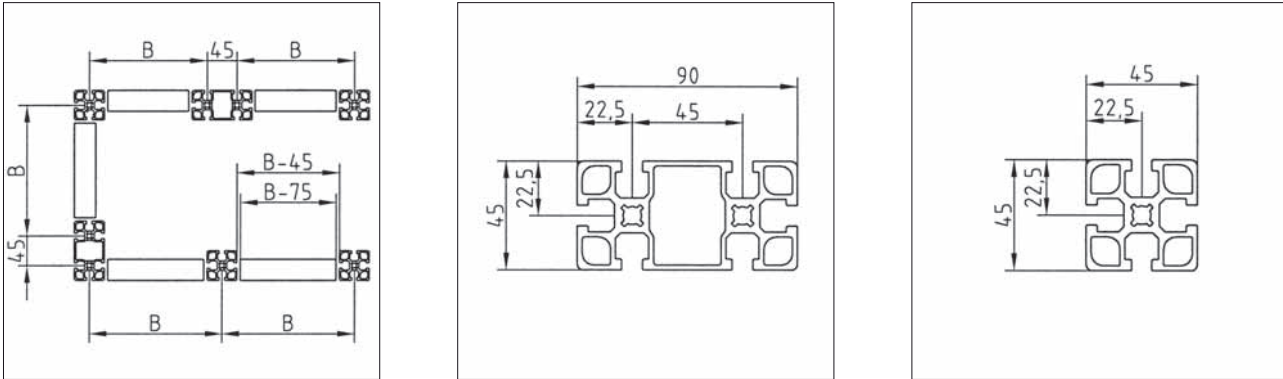

Standard widths

500, 750, 1000, 1250, 1500 mm
 1500, 1750, 2000 mm with additional vertical center strut

The protective field frames consist of specially designed clamping profiles 32x32 mm. Due to the great depth of the receiving groove for the surface elements in conjunction with the securing by distance profile great stability is achieved. For fastening attachments all components of the MiniTec profile system can be used.

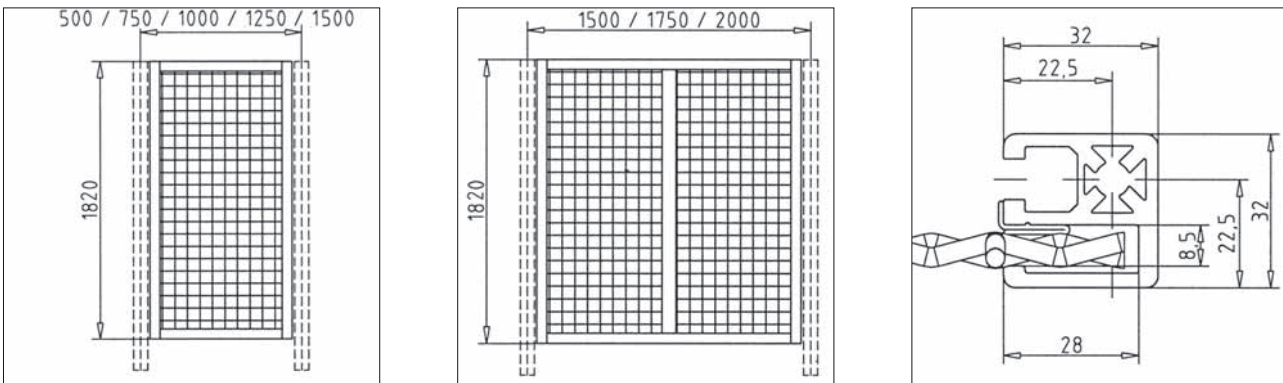

Height

Standard overall height „HG”= 2000 mm,
 Protective field height HS 1820 mm, 180 mm ground clearance for disability-free cleaning

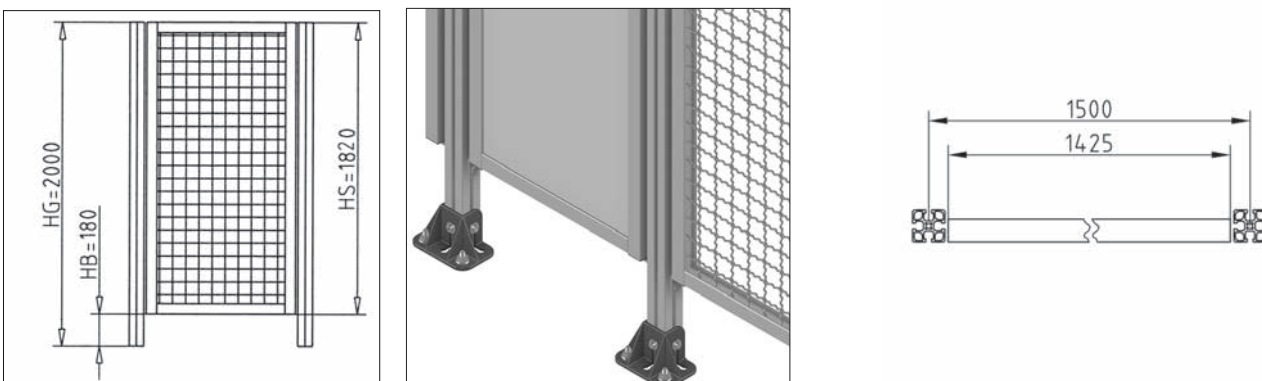

PROTECTION SYSTEM SAFE GUARD

ASSEMBLY



The assembly of the pre-assembled fields in place can be carried out by one person. With sturdy feet, the posts are attached to the ground with heavy-duty dowels. The posts are provided with angles, in which the protective fields are hung and screwed. The fields can be aligned arbitrarily, by means of oblong holes in the angles can be compensated distance tolerances of the posts.



PROTECTION SYSTEM COMPONENTS

FIELD SG 500/750/1000/1250/1500 (WITHOUT MEDIUM STRENGTH)

Technical Data / Items Supplied

- made of clamping profile 32 x 32 UL, completely pre-assembled
- with wave grid 40 x 40 x 4 mm, galvanized steel or with polycarbonate 5
- Standard height HS: 1820 mm

Application

- for the separation of danger areas
- as machine protection

Assembly

- Protective field using fastening kit 19 Part no. 23.0010/0 or fastening kit for SG fields Part no. 23.0011/0
Mount on protective field posts

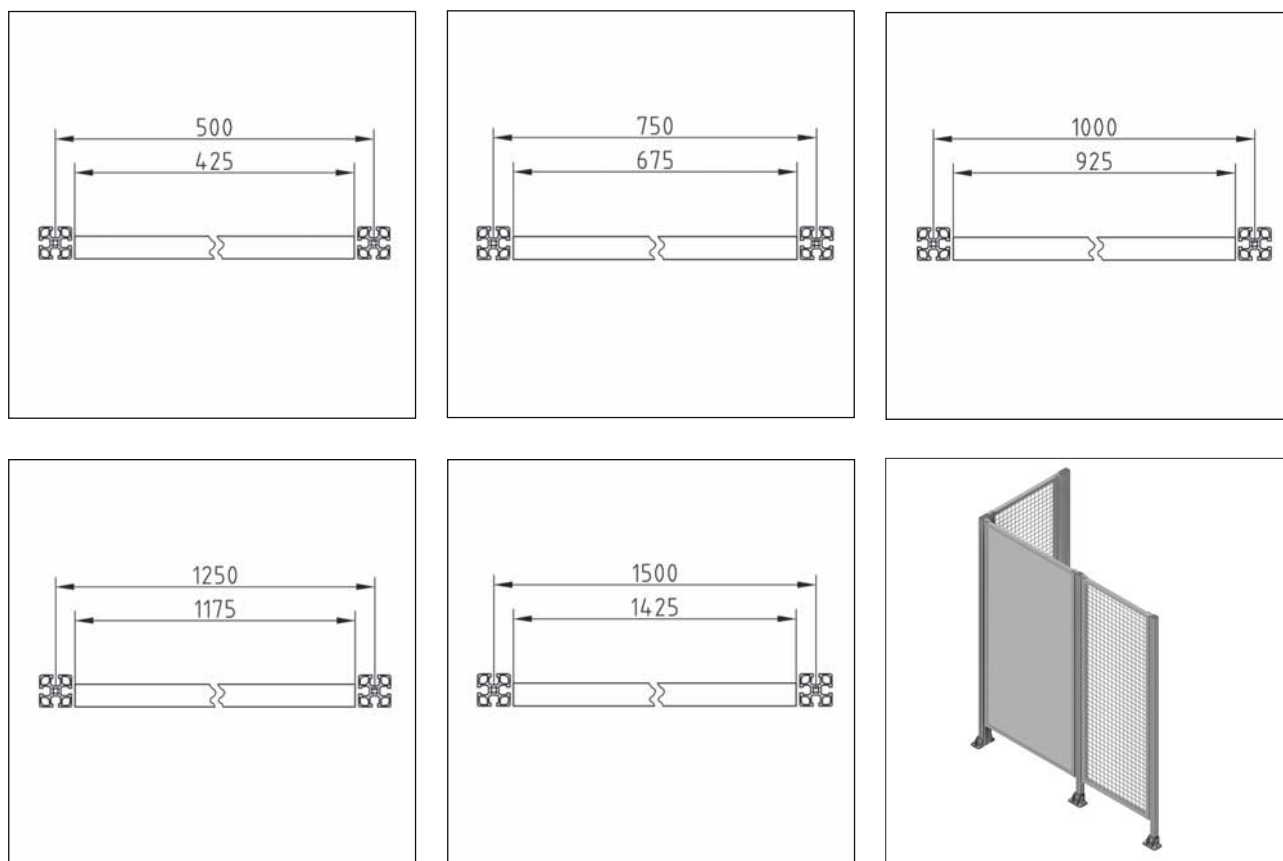

Field size B mm	Wave grid Part no.	Polycarbonate 5 Part no.
500	23.0102/0	23.0112/0
750	23.0103/0	23.0113/0
1000	23.0104/0	23.0114/0
1250	23.0105/0	23.0115/0
1500	23.0109/0	23.0119/0

PROTECTION SYSTEM COMPONENTS

FIELD SG 1500/1750/2000 (WITH MEDIUM STRENGTH)

Technical Data / Items Supplied

- made of clamping profile 32 x 32 UL, completely pre-assembled
- with wave grid 40 x 40 x 4 mm, galvanized steel or with polycarbonate 5
- Standard height HS: 1820 mm
- Vertical center bar made of clamping profile 45 x 32
- additional vertical intermediate strut

Application

- for the separation of danger areas
- as machine protection

Assembly

- Protective field using fastening set 19 Part no. 23.0010/0
- or fastening kit for SG fields Part no. 23.0011/0 mount on protective field posts

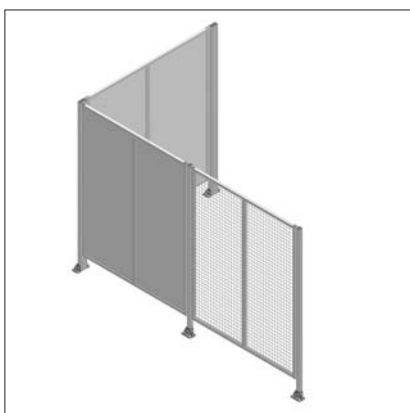
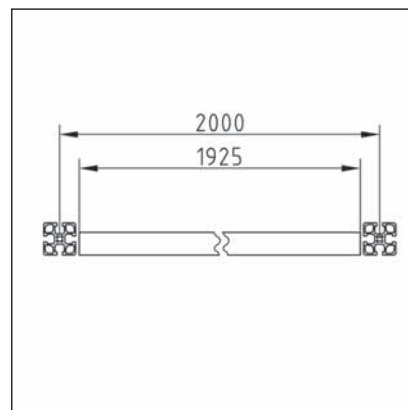
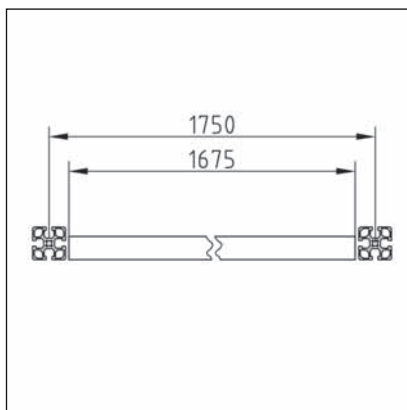
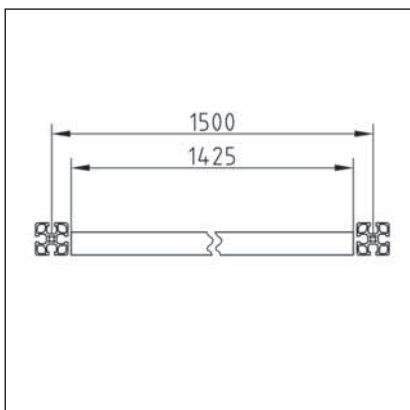

Field size B mm	Wave grid Part no.	Polycarbonate 5 Part no.
1500	23.0106/0	23.0116/0
1750	23.0107/0	23.0117/0
2000	23.0108/0	23.0118/0

PROTECTION SYSTEM REQUEST

FITTING FIELD

Fitting field

Height of protective field H	<input type="text"/>	mm (Standard 1820 mm)
Width protective field B (up to 75mm)	<input type="text"/>	mm
or		
Total height HG	<input type="text"/>	mm (Standard 2000 mm)
Ground clearance HB	<input type="text"/>	mm (Standard 180 mm)
Groove center distance B		
Surface element	<input type="checkbox"/> Wave grid <input type="checkbox"/> Polycarbonate	

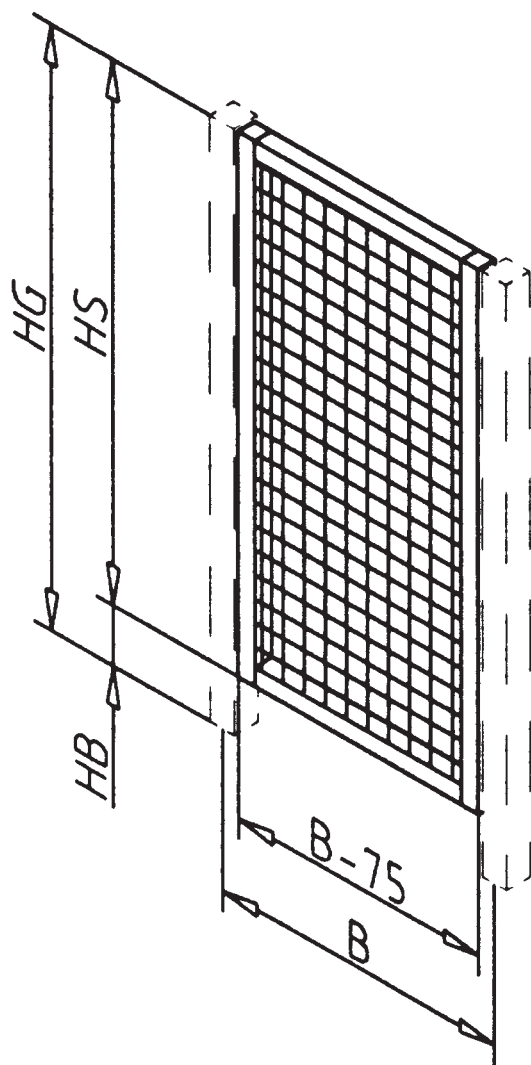

Contact details

Company	<input type="text"/>
Contact	<input type="text"/>
Phone number	<input type="text"/>
Fax number	<input type="text"/>
E-Mail	<input type="text"/>

Please call me back
I ask for a written offer

PROTECTION SYSTEM REQUEST

SLIDING DOOR

Sliding door

Post spacing B	<input type="text"/>	(Standard 1000 mm)
Post heightHG	<input type="text"/>	(Standard 2000 mm)
Handle	one-sided	both-sided
Surface element	Wave grid	Polycarbonate
Additional field fix	<input type="text"/>	
right	yes	no
left	yes	no

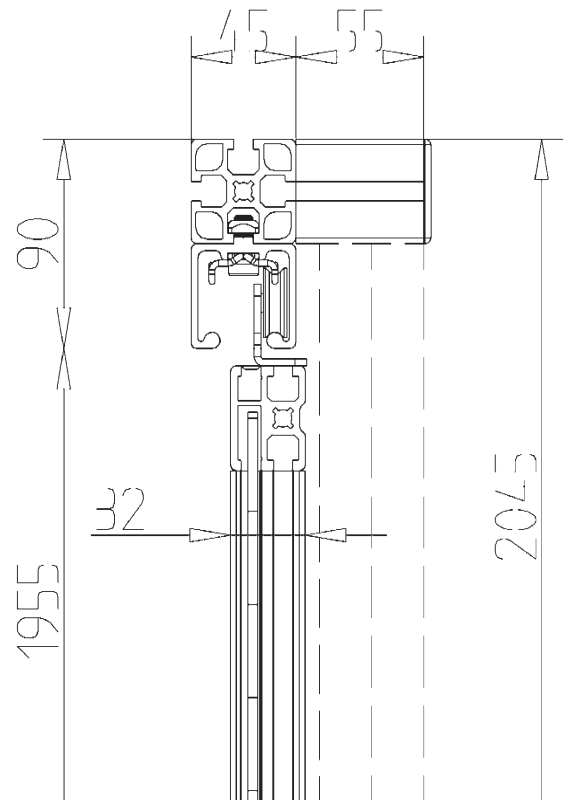
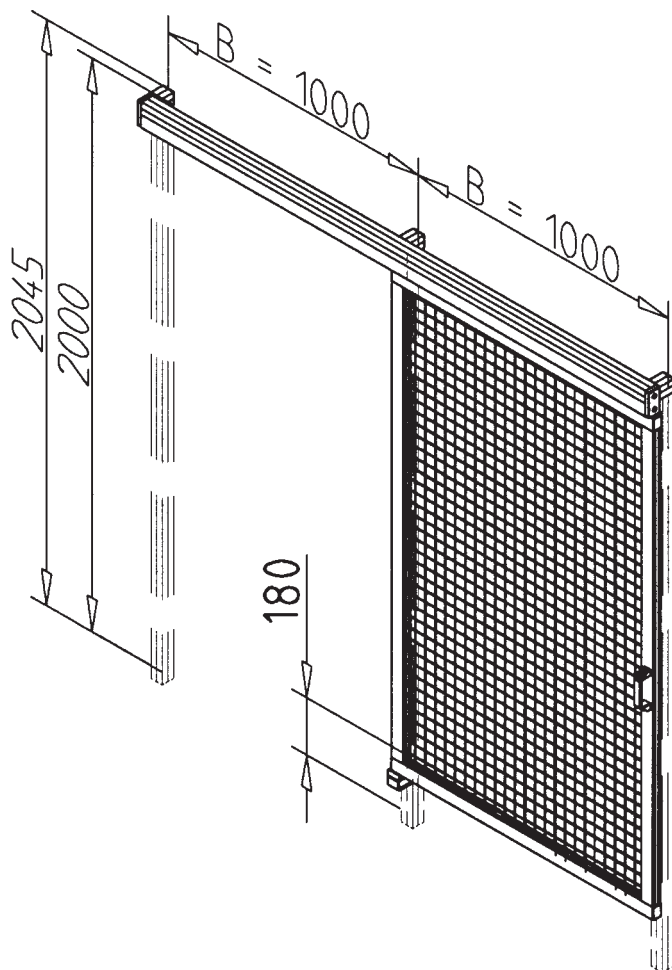

Contact details

Company

Contact

Phone number

Fax number

E-Mail

Please call me back
I ask for a written offer

PROTECTION SYSTEM REQUEST

LIFTING DOOR

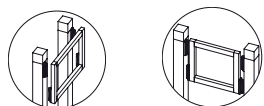

Lifting door

Lifting door arrangement	<input type="checkbox"/> outside	<input type="checkbox"/> inside
Groove center distance B	<input type="text"/>	mm
Lifting field height A	<input type="text"/>	mm
Stroke A3	<input type="text"/>	mm
Rally A1	<input type="text"/>	mm
Operation	<input type="checkbox"/> hand	<input type="checkbox"/> Pneumatic
Surface element	<input type="checkbox"/> Wave grid	<input type="checkbox"/> Polycarbonate
Strokes per hour	<input type="text"/>	
Additional field fix	<input type="text"/>	
right	<input type="checkbox"/> yes	<input type="checkbox"/> no
left	<input type="checkbox"/> yes	<input type="checkbox"/> no

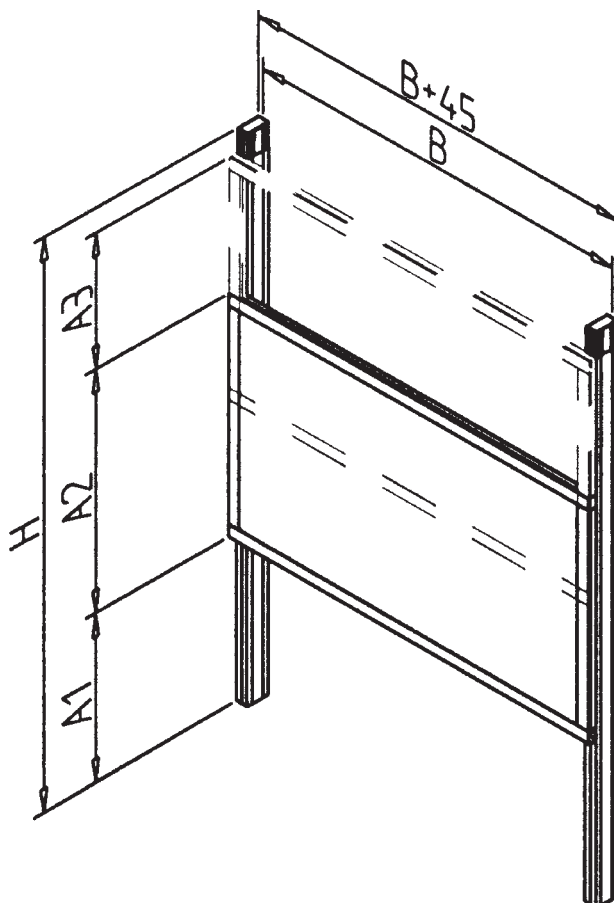

Contact details

Company	<input type="text"/>
Contact	<input type="text"/>
Phone number	<input type="text"/>
Fax number	<input type="text"/>
E-Mail	<input type="text"/>

Please call me back
 I ask for a written offer

Post SG 45 x 90

Part no.

23.0060/0

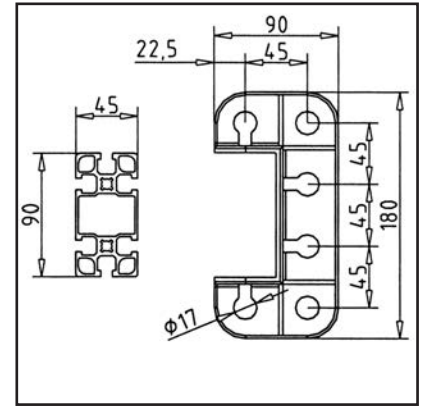
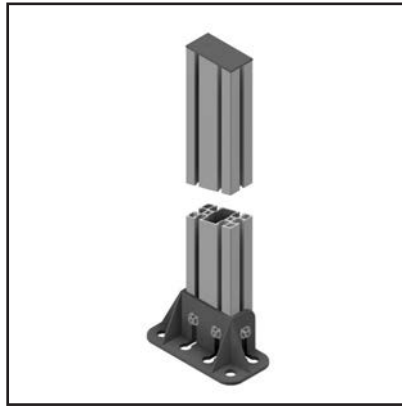
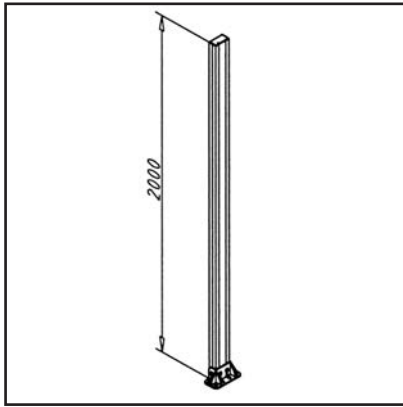
**TECHN. DATA / ITEMS SUPPLIED**

- Aluminium, extruded, anodized E6/EV1
- Made of profile 45 x 90 F
- Foot 90 GD preassembled
- Without ground anchor
- Weight = 6.740 kg/piece

APPLICATIONS

- Use as corner posts for guard units or for higher lateral loads of normal units

ASSEMBLY

- Position foot as appropriate
- Mark the position of the drillings on the ground
- Install and tighten the ground anchor

DOOR SG 1000 WG

Part no.

23.1404/0

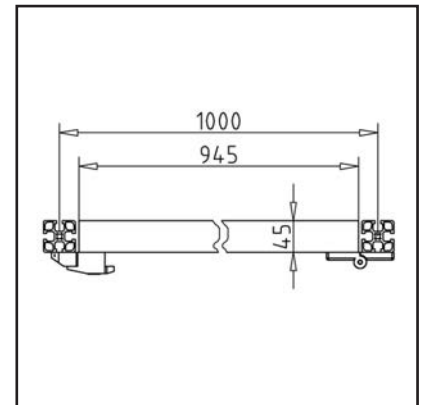
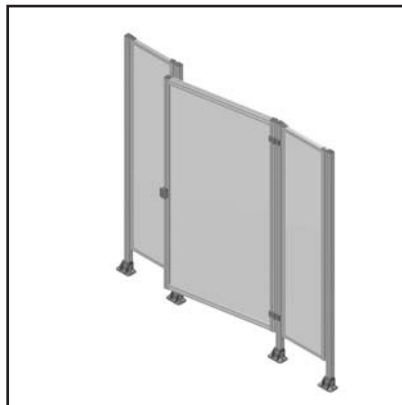
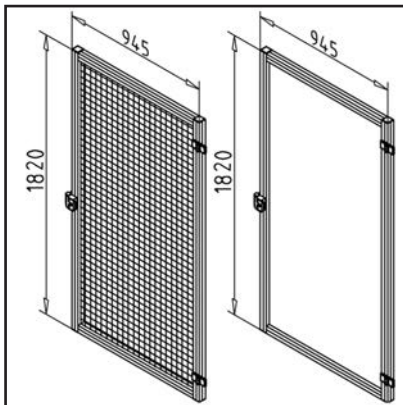
**TECHN. DATA / ITEMS SUPPLIED**

- Made of profile 45 x 45 F
- Fully pre-assembled with lock and hinges
- With polycarbonate 5, **part no. 23.1414/0**
- **Other versions upon request**
- Weight = 18.577 kg/piece

APPLICATIONS

- As access to enclosures e.g. for maintenance

ASSEMBLY

- Install between two posts with groove spacing 1000 mm
- Mount lock stopper onto posts with 2 bores
- Suitable for left and right stop

FASTENING KIT 19 FOR PROTECTIVE FIELDS

Part no.

23.0010/0

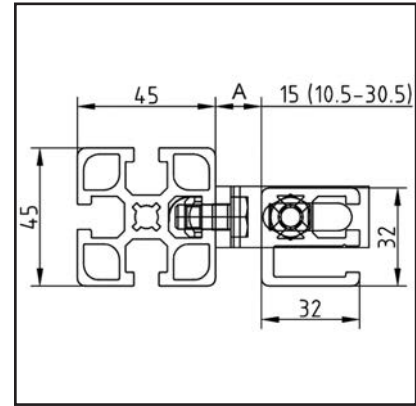
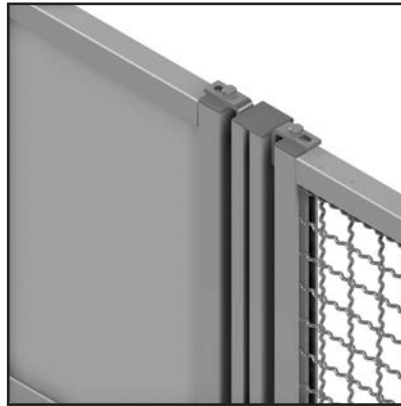
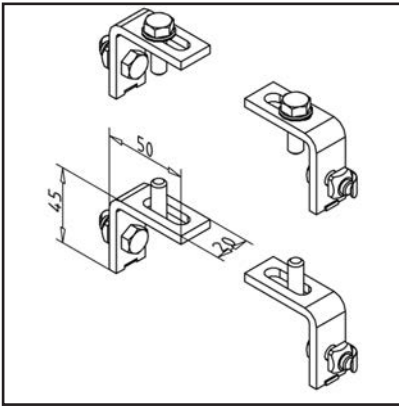

TECHN. DATA / ITEMS SUPPLIED

- Steel, galvanized
- With fastening material steel, zinc plated
- 4 protection field suspensions
- Weight = 0.500 kg/set

APPLICATIONS

- Fastening protective fields from clamping profile 32 x 32, 45 x 32 or standard profiles
- Attachment of protective fields at any angle

ASSEMBLY

- Insert protective field in pre-assembled lower suspension, tighten with screws from the scope of delivery above
- A = 10,5 mm - 30,5 mm

FASTENING KIT FOR SG FIELDS WITH CAPTIVE SCREW

Part no.

23.0011/0

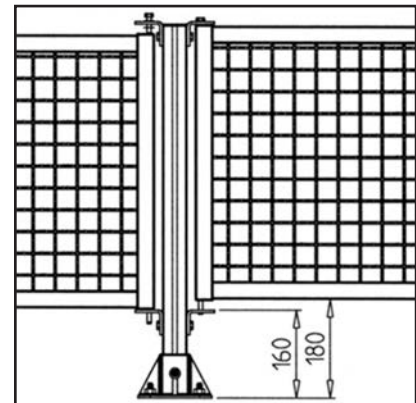
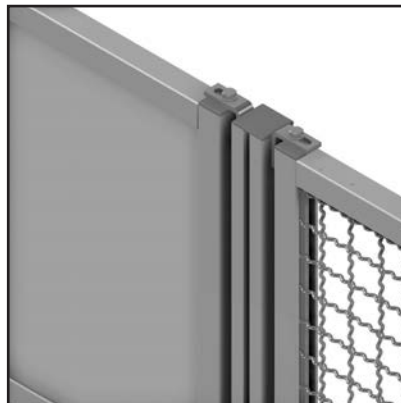
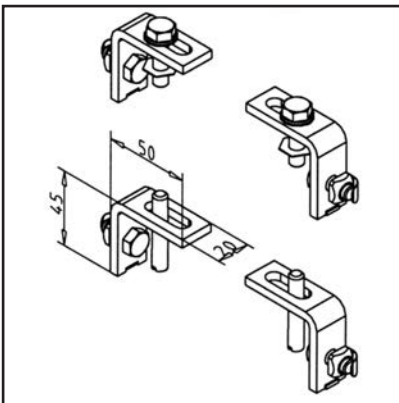

TECHN. DATA / ITEMS SUPPLIED

- Steel, galvanized
- With fastening material steel, zinc plated
- 4 protection field suspensions
- With label: Maintenance panel
- Top screws in non-detachable design
- Weight = 0.366 kg/set

APPLICATIONS

- Fastening protective fields which are removed for servicing purposes. The screws to be loosened here are in a captive design.
- For clamping profile 32 x 32 and 45 x 32
- Fastening of protection fields at any angle

ASSEMBLY

- Insert protective field in pre-assembled lower suspension, tighten with screws from the scope of delivery above
- A = 10,5 mm - 30,5 mm

NOISE PROTECTION

EXAMPLES

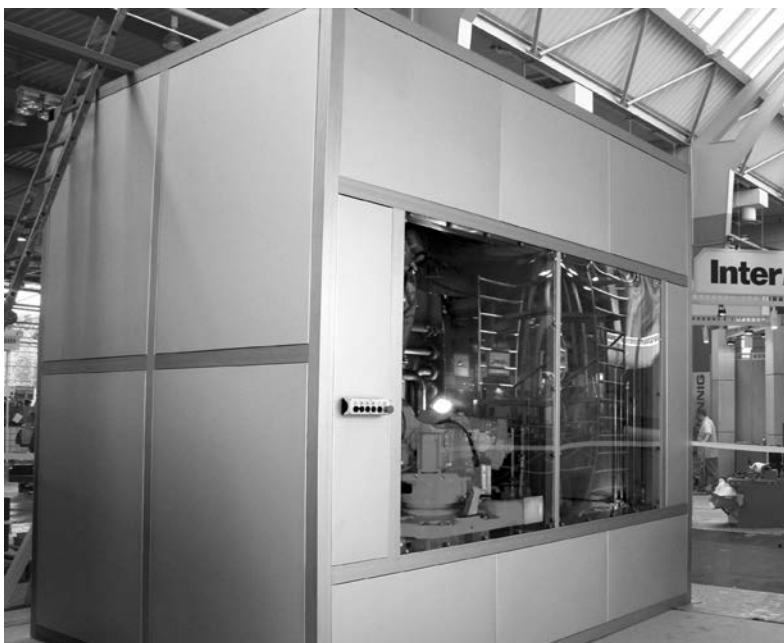

NOISE PROTECTION

2033/10/EG - EUROPEAN LABORATORY PROTECTION DIRECTIVE ON NOISE

To protect workers, the European Health and Safety Directive on noise (2033/10 / EC) was transposed into national law on 6 March 2007. The new ordinance will reduce intervention levels by 5 dB (A) to 80 dB (A) for preventive measures. Passive noise protection through the provision of suitable hearing protectors is a way of prevention. The disadvantage here is the complicated communication, the poorer recognizability of alarm and warning signals or uncomfortable protective equipment. Better is active noise protection by reducing the noise emission or housing the noise sources. There are relevant legal requirements for the avoidance of noise pollution, which oblige the entrepreneur to take suitable measures in accordance with the respective state of the art. In cooperation with the company Scharenberg in Tarmstedt, which specializes in noise protection,

the new modular system for protective cabins and noise-reducing enclosures was developed. The kit is based on the tried-and-tested MiniTec profile system combined with 20 mm noise protection mats or 34 mm noise protection cassettes. In the design of the kit, the simplest installation and maximum accessibility to the machine special attention was paid. Noise reduction of 25 dB (A) is achieved on a regular basis if the housing is designed properly in p34.





NOISE-STRESS CAUSES HEALTH DAMAGE



Depending on the intensity and duration of the exposure to noise, there may be acute and long-term adverse effects on the health, performance and well-being of employees.

- Psychosocial effects such as decreasing concentration, nervousness, irritability, aggressiveness
- Physiological and vegetative reactions such as hearing damage, constriction of the blood vessels, high blood pressure, heart and circulatory diseases, headache
- Reduced performance and increased risk of accidents, impaired communication, wrong decisions due to misunderstandings, increased error rate, reduced motivation

Rising health costs and the resulting loss of production make noise control so important. By reducing the noise level, the performance increases.



Advantages of the MiniTec noise protection solutions

- Safe noise reduction
- Economical by using the modular system
- Easy installation and construction with standard cassettes
- Optimum accessibility with doors, lifting doors, control windows
- Easy to dismantle walls
- Optionally with heat dissipation

NOISE PROTECTION

COMPONENTS & VERSIONS

Versions „p20”

- Basic construction with MiniTec aluminium profiles
- Surface element
- Sound absorption panel, PU foam 20 mm thick, black, part no. 21.1879/0, For bonding to surface elements Weight approx. 650 g / m², temperature resistance: -40 to + 100 ° C

Selection of surface elements

- Aluminium sheet 2 mm, anodized, part no. 21.1011/0, installed with plug-in seal 2, part no. 22.1083/0
- Sheet steel 1 to 2 mm, painted or galvanized, installed with plug-in seal 2, part no. 22.1083/0
- Chipboard 8 mm, both sides coated white, part no. 21.1815/2
- Chipboard 8 mm, light grey coated on both sides, part no. 21.1855/0



Sound absorption level Measurement according to DIN-EN-ISO 103534-2

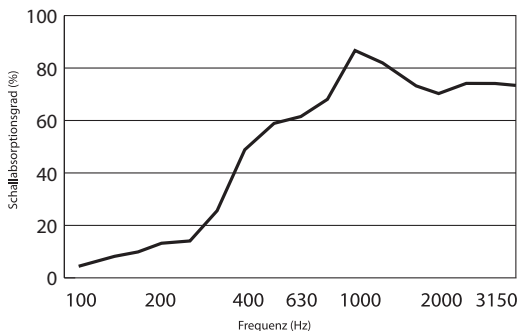

Versions „p34”

- Basic construction with MiniTec aluminum profiles
- Noise protection bar, Part no. 22.1130/1
- Noise protection cassettes 34 mm thick
- Inside perforated sheet, filling made of high-quality mineral wool, with glass fleece as trickle protection, non-flammable according to DIN 4102, building material class A2
- Outside galvanized steel sheet, optionally painted according to RAL
- Cassette size (B / H) = clear width of frame construction - 8 mm

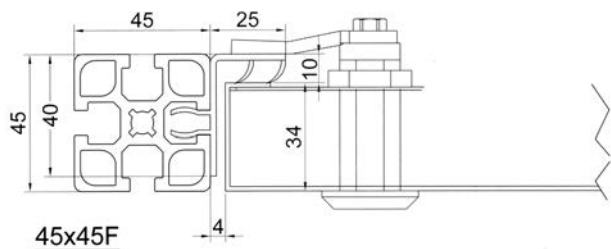

NOISE PROTECTION

COMPONENTS & VERSIONS

Noise protection bar (Part no. 22.1130/1)

- Material: ABS grey
- with two molded sealing lips
- Weight 0,232 kg/m
- Tool-free installation of the strip, no screws required
- Suitable for retrofitting
- Easy to edit, easy to replace
- Low installation times
- Sealing of removable walls, door hinges
- no miter cut required

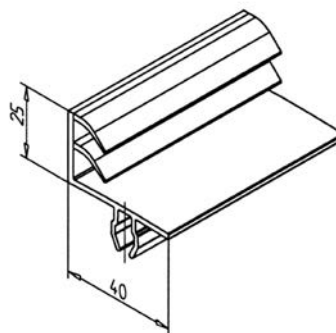
**Noise protection cassette p34**

- Thickness 34 mm
- 1.5 mm galvanized sheet steel, optionally painted to RAL
- Insulating material mineral fiber laminated, approx. 90 kg / m³
- 1.0 mm perforated sheet inside, galvanized, approx. 35% perforation
- Sound insulation according to ISO 140-3 acc. Certificate
- Cassette weight 27 kg/m²



Hinged with sash lock

Versions

- Cassette firmly screwed
- Cassette detachable with sash lock
- Door with latch handle



Cassette firmly screwed

Options

- Window 1-fold or 2-fold
- Paint according to RAL
- Plate silencer
- Channel sound absorbers
- Fan with thermostat
- Sliding doors
- Rain cover



Door with latch handle

NOISE PROTECTION

COMPONENTS & VERSIONS

Preferred cassette sizes noise protection p34

Groove center distance N mm	Cassette size mm	Cassette firmly screwed Part no.	Cassette can be hung up Part no.	Door Part no.
250 x 250	197 x 197	56.0011/0	56.0012/0	56.0013/0
500 x 250	447 x 197	56.0021/0	56.0022/0	56.0023/0
1000 x 250	947 x 197	56.0031/0	56.0032/0	56.0033/0
250 x 500	197 x 447	56.0041/0	56.0042/0	56.0043/0
500 x 500	447 x 447	56.0051/0	56.0052/0	56.0053/0
1000 x 500	947 x 447	56.0061/0	56.0062/0	56.0063/0
250 x 1000	197 x 947	56.0071/0	56.0072/0	56.0073/0
500 x 1000	447 x 947	56.0081/0	56.0082/0	56.0083/0
1000 x 1000	947 x 947	56.0091/0	56.0092/0	56.0093/0
250 x 2000	197 x 1947	56.0101/0	56.0102/0	56.0103/0
500 x 2000	447 x 1947	56.0111/0	56.0112/0	56.0113/0
1000 x 2000	947 x 1947	56.0121/0	56.0122/0	56.0123/0

Calculation of length for the noise protection strip and the panel size

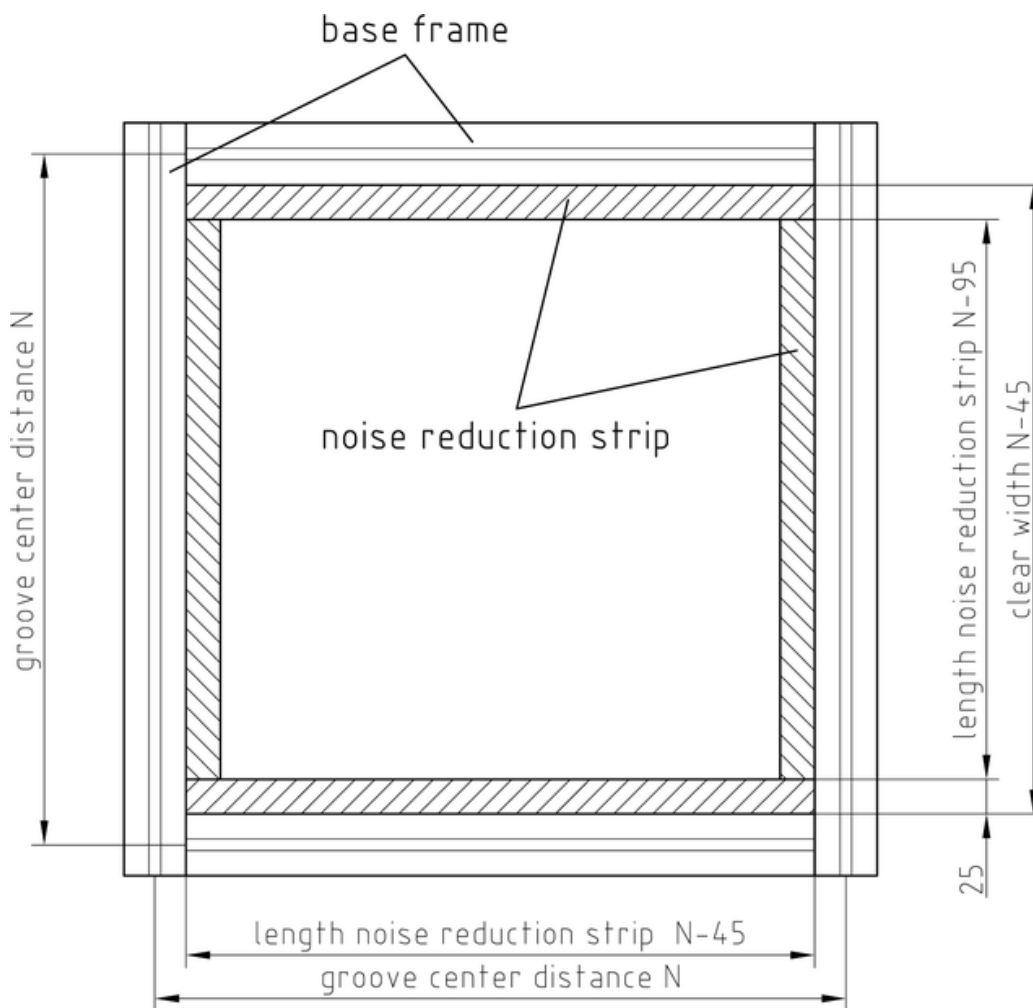

NOISE PROTECTION

INQUIRY NOISE PROTECTION

Dimensions of the machine

Width mm

Length mm

Height mm

Type of machine

Current noise emission dB(A)

Desired noise reduction dB(A)

Frequency range Hz

Heat dissipation required yes no

Contact details

Company Please call me back

Contact I ask for a written offer

Phone number

Fax number

E-Mail

SOUND ABSORPTION PLATE PYRAMID

Part no. 21.1819/0

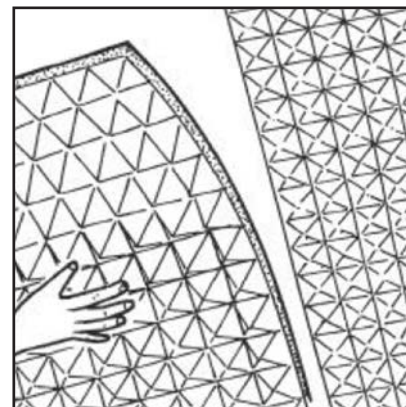
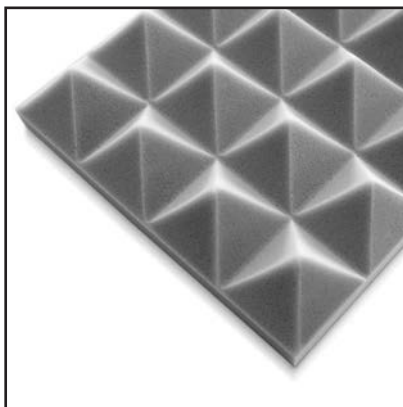
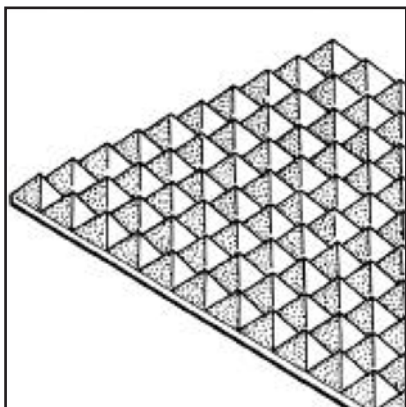

TECHN. DATA / ITEMS SUPPLIED

- Material: PUR-foam, anthracite, 70mm
- Fire protection classification 3
- **Other strenghts and performances on request**
- coefficient of thermal conductivity at 0°C 0,032 W/mK
- Board size max. 1000x1000mm
- Weight = 1.500 kg/m²

APPLICATIONS

- Primary noise protection by enclosing noise sources
- Secondary sound insulation in lounges, master offices, etc.

ASSEMBLY

- Fixing by gluing to the substrate
- Depending on the substrate, suitable adhesives are available upon request

SOUND ABSORPTION PLATE 20MM

Part no. 21.1879/0

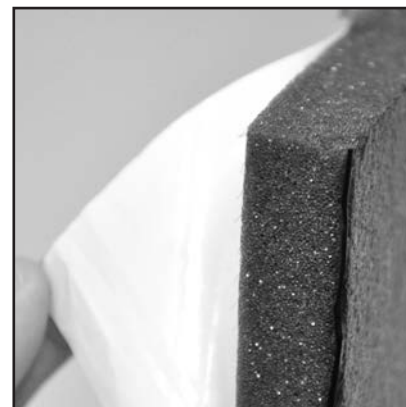
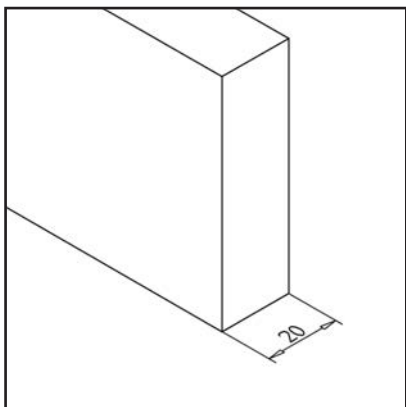

TECHN. DATA / ITEMS SUPPLIED

- Material: Pu-foam, 20mm, black, adhesive
- Board size max. 2000x1000mm
- Temperature resistant -40 to +100°C
- Weight = 0.650 kg/m²

APPLICATIONS

- Through the black PU-skin immune to pollution

ASSEMBLY

- Lamination sheet pull down and glue on



6.1

LONGITUDINAL STOPS

570



6.2

VEHICLE EXTENSION

573

LONGITUDINAL STOPS



MiniTec longitudinal stops are a proven turn-key solutions based on standard elements of the MiniTec profile system. Its modular structure enables optimum solutions for any kind of application. All stops are equipped with a height-adjustable foot with floor mounting points. The stop is Connected to the machine via adaptor plates. A Digital LCD Operator Panels attached directly to the machine at operators height. Simple dimension modifications, e.g. for saw blade thickness or distance between stop and tool can be carried out via Operator panel.

Standard lengths up to 6000 mm (measuring length: 5500 mm), longer lengths on request

Carrying roller width: 200-600 mm

Carrying roller distance: 200 mm

Height adjustment: ± 100 mm

Standard height: 850 mm

Standard connection: Right

Length measurement: magnetic tape

Measurement accuracy: $\pm 0,15$ mm

Measuring display: LCD, two lines

Carriage guide

Linear guide LR with 4 precision rollers, adjusted without backlash, shafts $\varnothing 12$ mm hardened stainless steel Cf 53, Mat.-No. 1.1213

Slide clamping

With motor drive automatic (electric) when reaching the stop position, with manual drive via switch (pneumatic) or via clamping lever

Motor drive

AC motor with positioning control, installed in housing. Travel speed: 0.6 m / s

Dimension entry with motor drive

Input terminal with membrane keypad and LED display, mounted at working height next to the machine

INQUIRY LONGITUDINAL STOPS

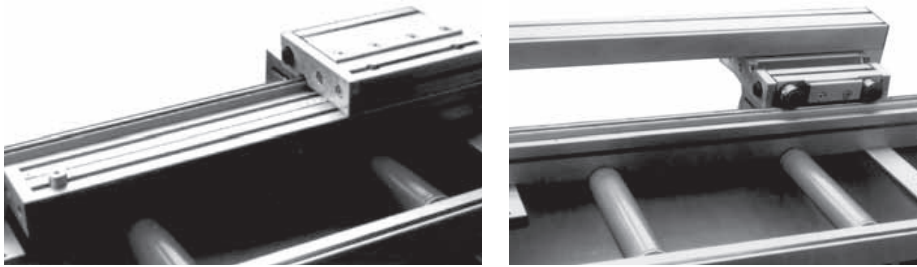

The entire stop head can be swivelled out of the roller conveyor by 180° for easy cutting. Adjustable measuring length compensation with scale, L = 400 mm, mounted on slide.

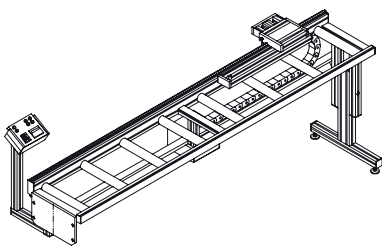

Motorized drive with stationary display, built in housing

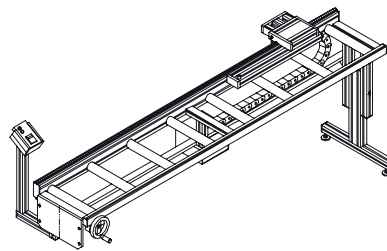

Manual crank drive with stationary 230V display

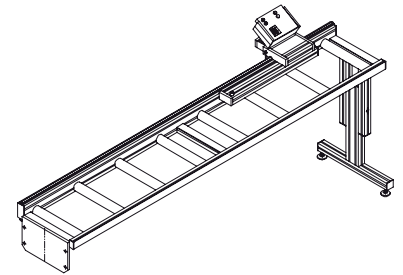

Manual carriage shift with battery operated digital display on stop slides

Basic dimensions

Measuring length Lm	<input type="text"/>	mm
Roller distance	<input type="text"/>	mm
Roll width	<input type="text"/>	mm
Circulation	<input type="text"/>	mm
Load	<input type="text"/>	kg

Control

Power unit	<input type="checkbox"/> by motor	<input type="checkbox"/> crank	<input type="checkbox"/> manually movable
Stop	<input type="checkbox"/> right	<input type="checkbox"/> left	

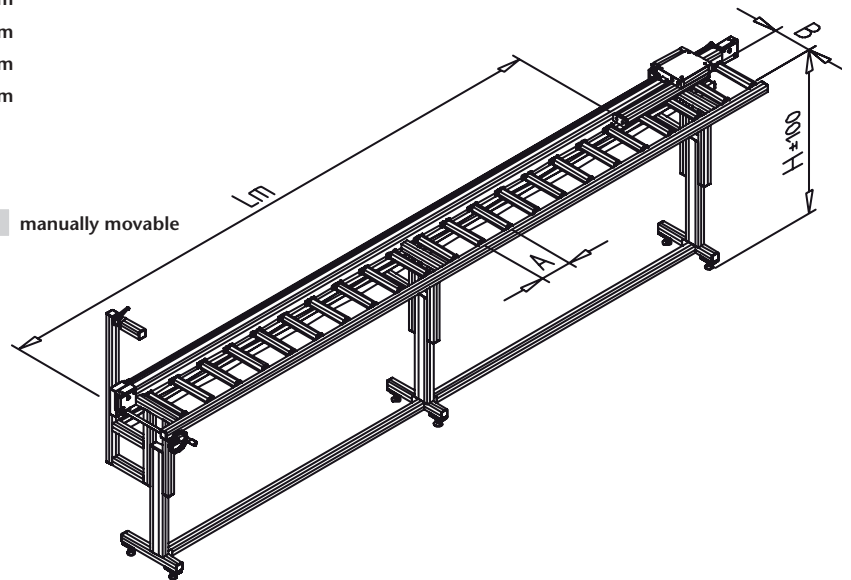

Contact details

Company	<input type="text"/>	<input type="checkbox"/> Please call me back
Contact	<input type="text"/>	<input type="checkbox"/> I ask for a written offer
Phone number	<input type="text"/>	
Fax number	<input type="text"/>	
E-Mail	<input type="text"/>	

VEHICLE EXTENSION

The profile system has proven itself in almost all industrial areas through the consistent groove system and patented joining techniques without machining. The MiniTec aluminium profile system is also frequently used in custom vehicle manufacture - by both professional vehicle manufacturers and emergency rescue organisations. By using the modular principle, modifications can be quickly and easily made at anytime to suit the ever

changing needs of the user. Workshops with customised assembly areas can quickly be transformed with modular shelving systems and transport trolleys for hoses and other equipment.





7.1

TOOLS

575



7.2

PROCESSING

586

MAGNETIC BIT HOLDER TORX

Part no.

26.1820/0

**TECHN. DATA / ITEMS SUPPLIED**

- Automatic holder with strong permanent magnet
- Inclusive Torx Bit T 40 x 25 **part no. 26.1822/0**
- Weight = 0.046 kg/piece

APPLICATIONS

- Holder of Bits Torx 40 for self-tapping screws M8 for mounting profile connectors

ASSEMBLY

- Retains the screws optimal on the tool in every position even at high revolution speed

T-HANDLE KEY TORX T40

Part no.

26.1814/0

**TECHN. DATA / ITEMS SUPPLIED**

- Tool, chromium plated
- Plastic T-handle, black
- Weight = 0.085 kg/piece

APPLICATIONS

- Fastening of MiniTec power-lock fastener SF

T-HANDLE KEY WITH CROSS-HANDLE

Part no.

--,----/-

**TECHN. DATA / ITEMS SUPPLIED**

- Tool, chromium plated
- Plastic T-handle, black
- SW 4 **part no. 26.1810/0**
Weight 0,032 kg
- SW 5 **part no. 26.1083/0**
Weight 0,053 kg

APPLICATIONS

- Fixation of Minitec power lock fastener and all kinds of screws

COMBI L-KEY

Part no.

--,----/-

**TECHN. DATA / ITEMS SUPPLIED**

- Tool, chromium plated
- one-sided with ball head
- SW 4 **part no. 26.1811/0**
Weight 0,016 kg
- SW 5 **part no. 26.1085/0**
Weight 0,030 kg

APPLICATIONS

- Fixation of Minitec power lock fastener and all kinds of screws

T-HANDLE KEY BALL HEAD

Part no.

--...../-

**TECHN. DATA / ITEMS SUPPLIED**

- Tool, chromium plated
- Green plastic handle
- SW 4 **part no. 26.1817/0**
Weight 0,038 kg
- SW 5 **part no. 26.1084/0**
weight 0.056 kg

APPLICATIONS

- Fixation of Minitec power lock fastener and all kinds of screws

DRILLING JIG 30

Part no.

26.1065/0

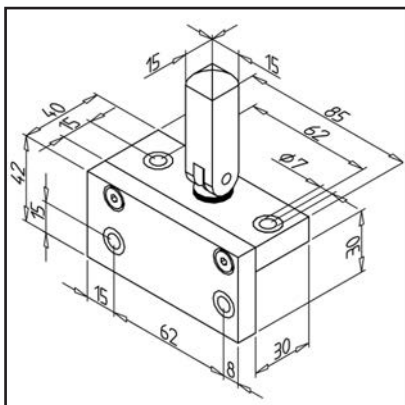
**TECHN. DATA / ITEMS SUPPLIED**

- Steel drill bushes \varnothing 7 mm
- Eccentric clamp device
- Material: Aluminium
- Weight = 0.282 kg/piece

APPLICATIONS

- 1) Positioning of step drilling for screw-connection
- 2) Connection bore on profile panel for pneumatic screw connections
- 3) Pre-drilling for step drilling for screw connection of profile 32 x 32
- Fitting for all profiles of profile series 30

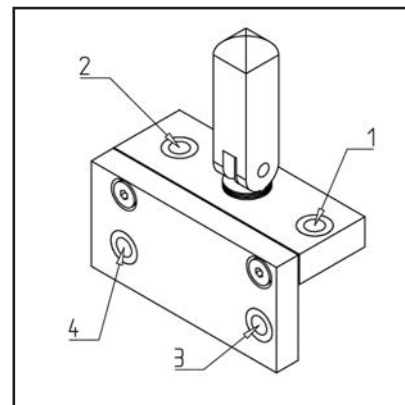
**ASSEMBLY**

- Tighten the drilling jig to the profile groove and drill with a suitable drill through the provided bushing
- The bore \varnothing 7 mm can be closed with plug 7 **part no. 22.1215/1**, should be used with our closed t-slot profiles

DRILLING JIG

Part no.

26.1092/0

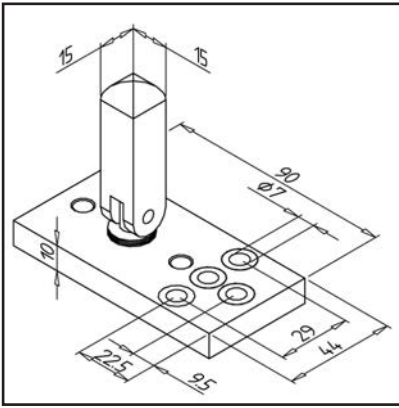

TECHN. DATA / ITEMS SUPPLIED

- Steel drill bushes \varnothing 7 mm
- Eccentric clamp device
- Material: Aluminium
- Weight = 0.220 kg/piece

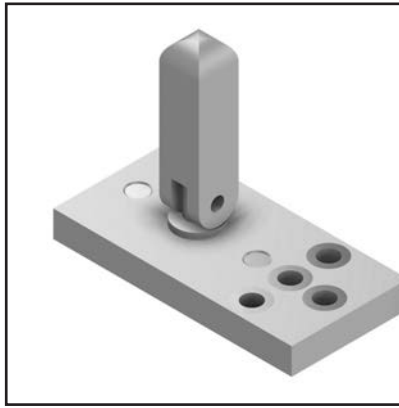

APPLICATIONS

- 1) Positioning of step drilling for screw-connection
- 2) Connection bore on profile panel for pneumatic screw connections
- 3) Pre-drilling for step drilling for screw connection of profile 32 x 32
- Fitting for all profiles of profile series 45

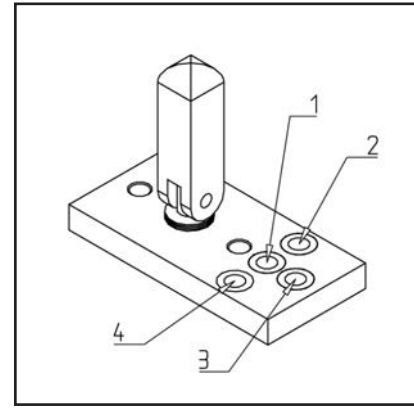

ASSEMBLY

- Tighten the drilling jig to the profile groove and drill with a suitable drill through the provided bushing
- The bore \varnothing 7 mm can be closed with plug 7 **part no. 22.1215/1**, should be used with our closed t-slot profiles

DRILLING JIG FOR MITRE 30

Part no.

26.1063/0

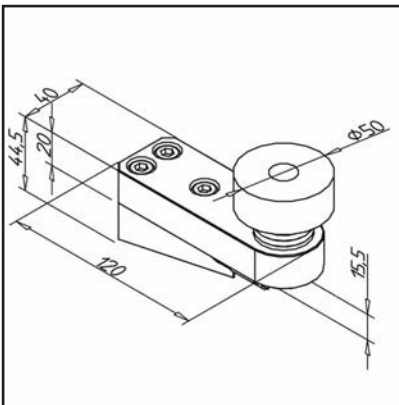

TECHN. DATA / ITEMS SUPPLIED

- Centering pin: steel
- Fixation screw: Plastic with steel bore bushing
- Material: Aluminium
- Weight = 0.408 kg/piece

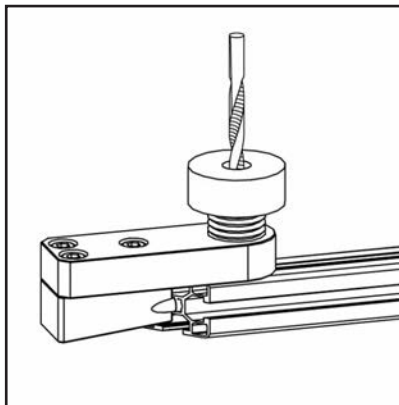

APPLICATIONS

- Positioning of bore for set screw of mitre connector 30 in relation to mitre angle
- Fitting for all profiles of profile series 30

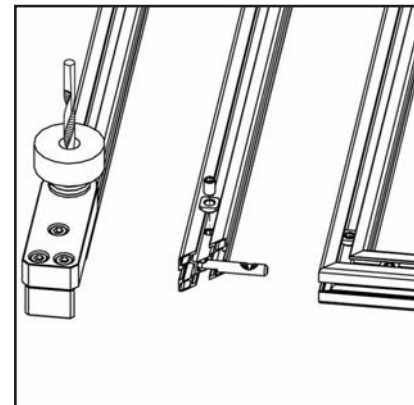

ASSEMBLY

- Cut profile in desired angle
- Insert the plug gauge until the stop, tighten the plastic locking screw
- Insert bore \varnothing 8.0 mm into profile at corresponding depth through drill bush
- Insert a drilling jig 30 **part no. 21.1890/0**

DRILLING JIG FOR MITRE N30

Part no.

26.1056/0

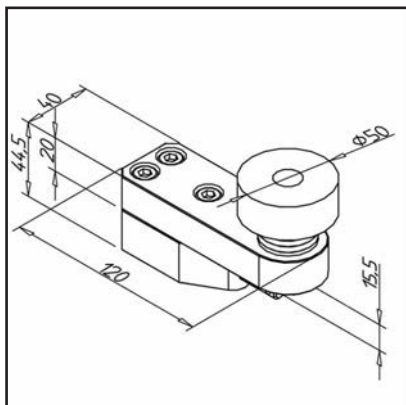
**TECHN. DATA / ITEMS SUPPLIED**

- Centering pin: steel
- Fixation screw: Plastic with steel bore bushing
- Weight = 0.477 kg/piece

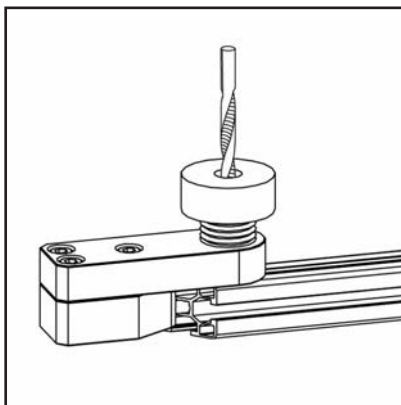
**APPLICATIONS**

- Positioning of bore for set screw of mitre connector N30 in relation to mitre angle
- Fitting for all profiles of profile series 30

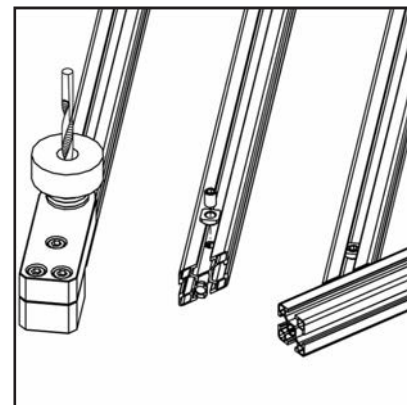
**ASSEMBLY**

- Cut profile in desired angle
- Insert the plug gauge until the stop, tighten the plastic locking screw
- Insert bore \varnothing 8.0 mm into profile at corresponding depth through drill bush
- Insert a drilling jig for mitre connector N30 **part no. 21.0945/0**

DRILLING JIG FOR MITRE 45

Part no.

26.1050/0

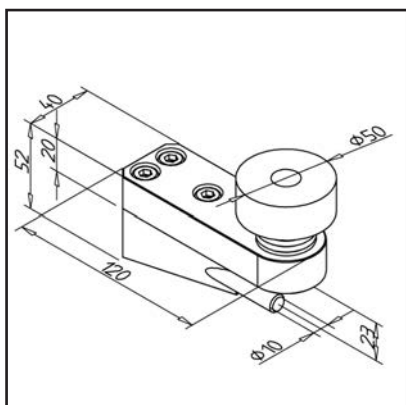
**TECHN. DATA / ITEMS SUPPLIED**

- Material: Aluminium
- Centering pin: steel
- Fixation screw: Plastic with steel bore bushing
- Weight = 0.450 kg/piece

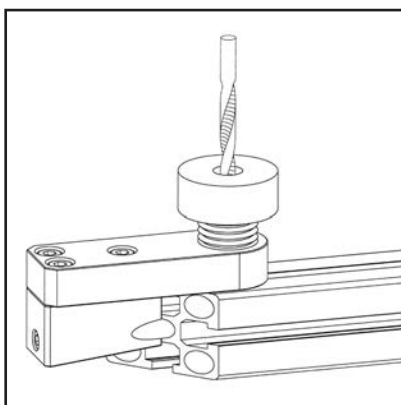
**APPLICATIONS**

- Production of the fastening bore for miter connectors 45 depending on the miter angle.
- Fitting for all profiles of profile series 45

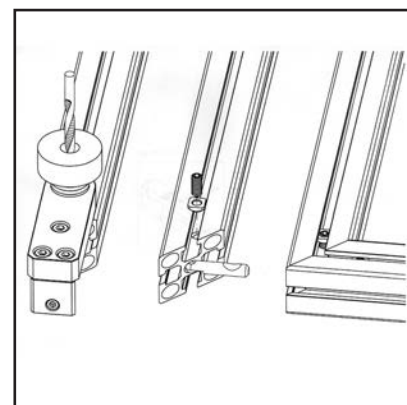
**ASSEMBLY**

- Cut profile in desired angle, rebore the center-bore \varnothing 10,1 mm with twist drill **part no. 26.1816/0**
- Insert the plug gauge until the stop, tighten the plastic locking screw
- Insert bore \varnothing 8.0 mm into profile at corresponding depth through drill bush
- Insert mitre-connector

DRILLING JIG FOR MITRE N 45

Part no.

26.1060/0

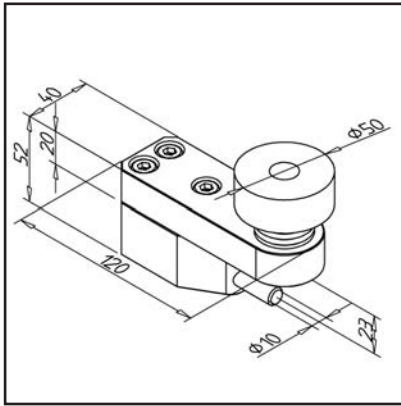
**TECHN. DATA / ITEMS SUPPLIED**

- Material: Aluminium
- Centering pin: steel
- Fixation screw: Plastic with steel bore bushing
- Weight = 0.556 kg/piece

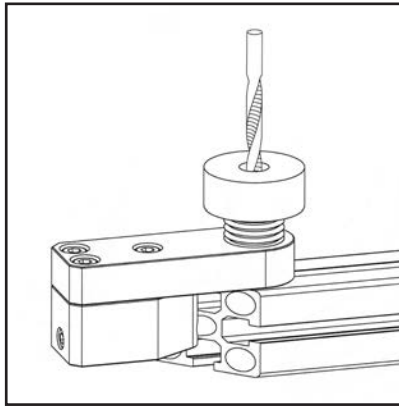
**APPLICATIONS**

- Production of the fastening bore for miter connectors N45 depending on the miter angle.
- Fitting for all profiles of profile series 45

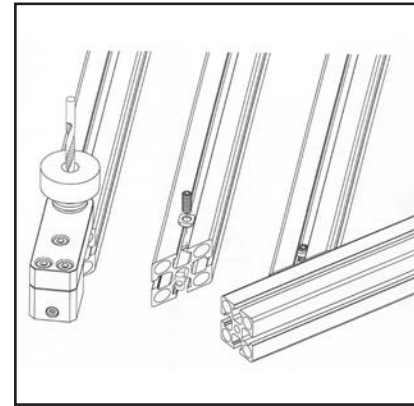
**ASSEMBLY**

- Cut profile in desired angle, rebore the center-bore $\varnothing 10,1$ mm with twist drill **part no. 26.1816/0**
- Insert the plug gauge until the stop, tighten the plastic locking screw
- Insert bore $\varnothing 8.0$ mm into profile at corresponding depth through drill bush
- Insert mitre-connector

THREAD FORMER M8

Part no.

26.1082/0

**TECHN. DATA / ITEMS SUPPLIED**

- HSS-tool steel
- Weight = 0.031 kg/piece

APPLICATIONS

- Chipless production of central thread M8 in all profiles

STEP DRILL

Part no.

--...../-

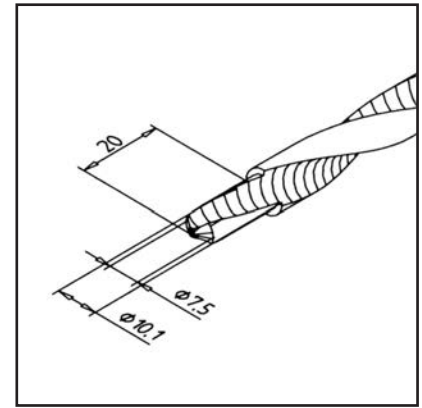
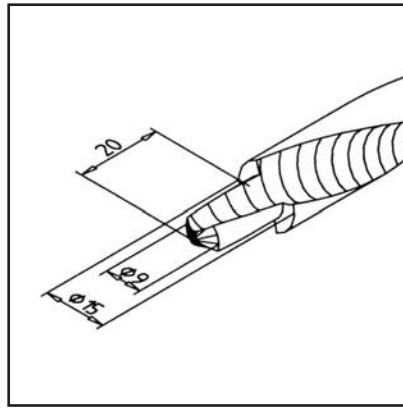
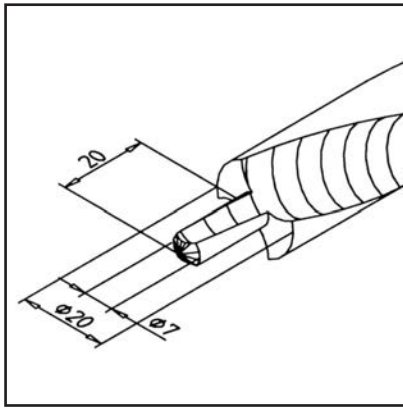
**TECHN. DATA / ITEMS SUPPLIED**

- HSS-tool steel
- Step drills 20 **part no. 26.1813/0**
Steps: \varnothing 7 mm / \varnothing 20 mm
Shaft: MK 2
Weight: 0,2650 kg
- Step drills 15 **part no. 26.1815/0**
Steps: \varnothing 9 mm / \varnothing 15 mm
Shaft: cylindrical \varnothing 15 mm
Weight: 0,1350 kg

- Step drills 10,1 **part no. 26.1816/0**
Steps: \varnothing 7,5 mm / \varnothing 10,1 mm
Shaft: cylindrical \varnothing 10,1 mm
Weight: 0,0520 kg

APPLICATIONS

- Step drill 20
Preparation of step bores for bolt and butt connector 20 in profiles of the series 45
- Step drill 15
Preparation of step bores for bolt and butt connector 15 in profiles of the series 45, narrow sides 19 and 32
- Step drill 10.1
Drilling of central bore in profiles of series 45 for mitre-connectors

PISTOL FORM IMPULSE WRENCH

Part no.

26.0800/0

**TECHN. DATA / ITEMS SUPPLIED**

- Pneumatically driven impulse wrench
- Quick-change chuck 1/4"
- Connection with 1/4 " quick coupling
- Magnetic bit holder with Torx bit T40
- Air consumption ca. 0,4 m³/min
- Speed at idle ca. 7000 Rpm
- Torque ca. 20 Nm
(without torque shutdown)
- Weight = 0.991 kg/piece

APPLICATIONS

- For screwing in self-tapping screws for MiniTec power-lock fasteners
- By pre-switching a hydraulic element, a soft shock is generated, thus particularly gentle joint work

THREAD FORMING MACHINE

Part no.

26.1910/0

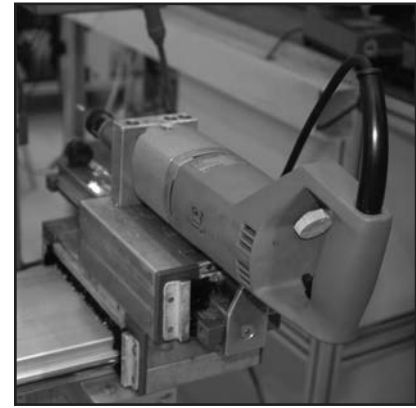
**TECHN. DATA / ITEMS SUPPLIED**

- Automatic change of direction, rapid return, 230 V, 280 W
- For threads up to M10
- Complete with chuck
- Spindle neck \varnothing 43 mm
- Weight = 1.700 kg/piece

APPLICATIONS

- Efficient thread production in conjunction with the tapping device

THREAD FORMING AND DRILLING MACHINE

Part no.

26.1970/0

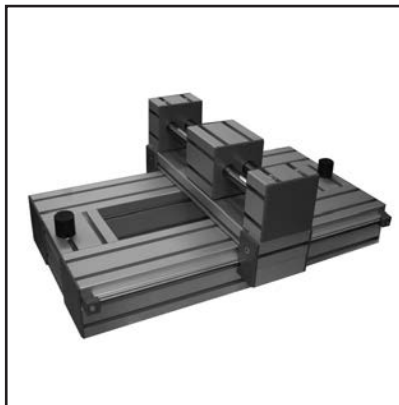
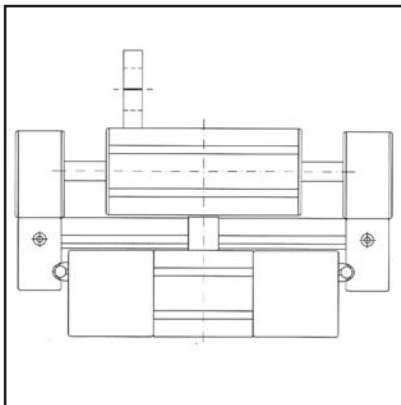
**TECHN. DATA / ITEMS SUPPLIED**

- Made of MiniTec aluminium profiles
- Two-axis slides with machine holder for thread cutting or drilling machines with spindle neck \varnothing 43 mm
- Complete with underframe
- Without machine
- Weight = 16.000 kg/piece

APPLICATIONS

- Rational thread production
- Efficient counter-boring or drilling of the central bore
- Can be delivered with 1 - 4 slides for up to 4 machines

GROOVE OPENER

Part no.

26.0815/0

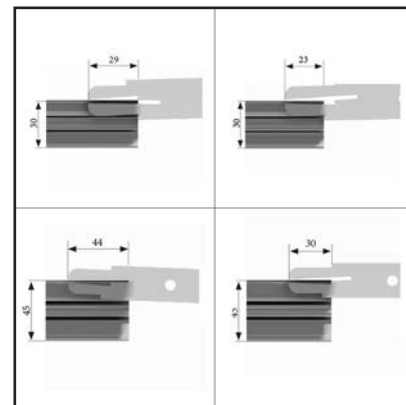
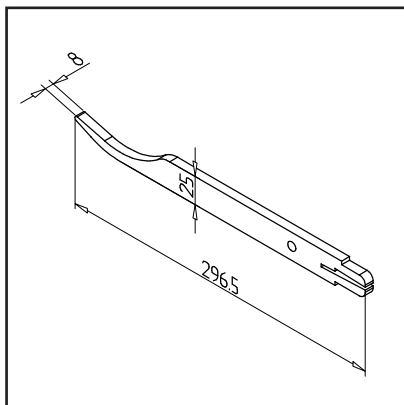

TECHN. DATA / ITEMS SUPPLIED

- Stainless steel, blasted
- Weight = 0.356 kg/piece

APPLICATIONS

- Rational tearing off of closed grooves in MiniTec aluminium profiles, for ex. for the mounting of surface elements, attachment of linear guides, etc.
- Efficient breaking out of the groove cover for the assembly of MiniTec profile connectors
- Suitable for all profiles of series 30
- Suitable for profile series 45

APPLICATION

- Place the slotted end of the tool on the end of the profile on the groove cover and break it upwards by repeated swiveling. The resulting break-out is designed for the assembly of MiniTec profile connectors
- After assembly, it is closed with an end cap G **part no. 22.1056/0** in the profile series 45 and end cap G **part no. 22.1182/1** for the profile series 30.
- Push the curved end of the tool at the profile end under the groove cover and pry it to the required length. To close wide open grooves with cover profile

DEBURRING TOOL

Part no.

26.0813/0

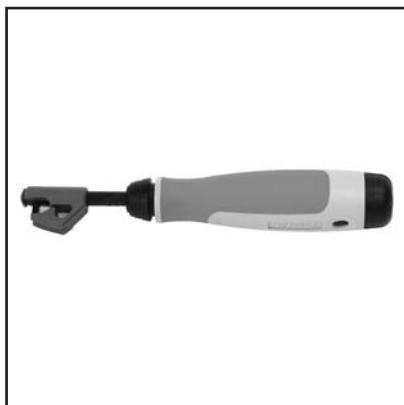

TECHN. DATA / ITEMS SUPPLIED

- Plastic handle
- Replaceable deburring tool
- Weight = 0.090 kg/piece

APPLICATIONS

- For deburring of the profile groove after opening the grooves of profiles by closed profiles
- For deburring of bores
- Extendable from ca 150-235 mm

ASSEMBLY

- Position it at the edge of the area to be deburred and pull it along

UNIVERSAL DEBURRER WITH S - BLADE

Part no.

26.1150/0

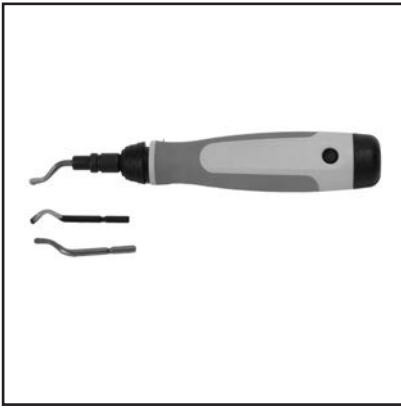
**TECHN. DATA / ITEMS SUPPLIED**

- Plastic handle
- Replaceable deburring tool
- 3 different blades
- Weight = 0.082 kg/piece

**APPLICATIONS**

- For deburring of the profile groove after opening the grooves of profiles by closed profiles
- For deburring of bores
- Extendable from ca 150-235 mm

ASSEMBLY

- Position it at the edge of the area to be deburred and pull it along

GROOVE DEBURRING

Part no.

26.0818/0

**TECHN. DATA / ITEMS SUPPLIED**

- Plastic handle
- Replaceable deburring tool
- Weight = 0.084 kg/piece

**APPLICATIONS**

- For deburring of the profile groove after opening the grooves of profiles by closed profiles
- For deburring of bores
- Extendable from ca 150-235 mm

ASSEMBLY

- Position it at the edge of the area to be deburred and pull it along

FLAT PLIERS

Part no.

26.0814/0

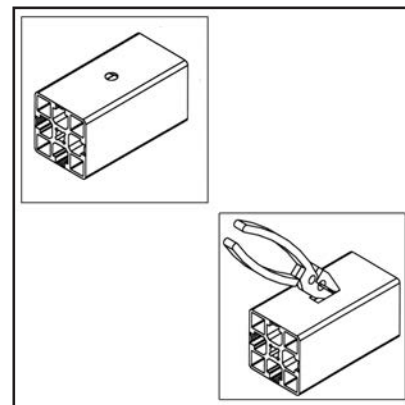
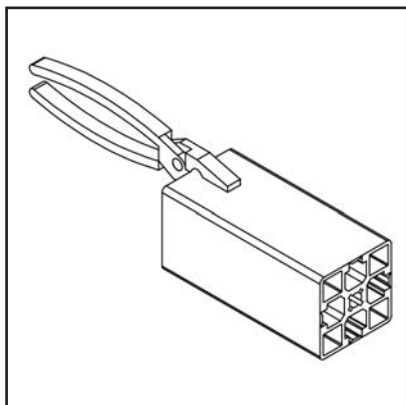
**TECHN. DATA / ITEMS SUPPLIED**

- Metal pliers with plastic handle
- Weight = 0.150 kg/piece

APPLICATIONS

- For breaking the profile groove in case of closed profiles

ASSEMBLY

- Fit the flat pliers to the closed groove and break the groove by repeated swiveling

ANODISING POLISHER

Part no.

26.0811/0

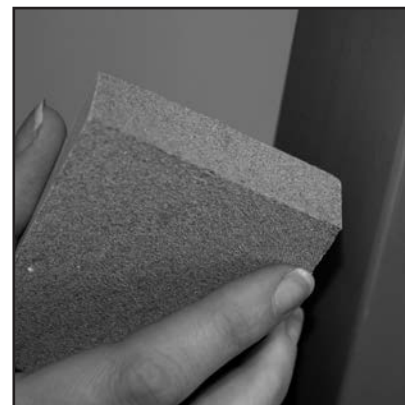
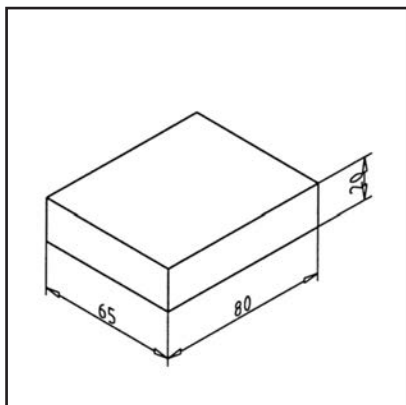
**TECHN. DATA / ITEMS SUPPLIED**

- Elastic bonded abrasive
- Weight = 0.138 kg/piece

APPLICATIONS

- to remove minor scratches on anodic coating
- to equal "shades" on anodic coating

ASSEMBLY

- also suitable for hard-to-reach positions (eraser can be cut to size)
- Dry and wet implementation – Water reinforces the functioning
- even polished sections without physical effort
- water- and oil-resistant
- ecofriendly, no detergents necessary
- Long life cycle

NEW APPLICATIONS WITH BENT PROFILES

- Decorative designs for trade show or office
- Functional design for swiveling constructions
- Machine cover
- Safety devices in machine contour
- Curved roller conveyors
- Ergonomic design of workplaces

Technical features

For standard applications, anodized profiles are used. Small cracks in the anodized layer may occur in the bent area. Subsequent anodization is only required for small radius or high optical demands. The profile cross-section is not changed during the bending process. All components can be used further. A minimum radius of 400 mm must be observed when using the MiniTec profile connector. G profiles with closed grooves and UL profiles are not suitable for the bending process. The bending process is CNC-controlled and controlled. With this bending technology different radius can be realized on the same profile bar.

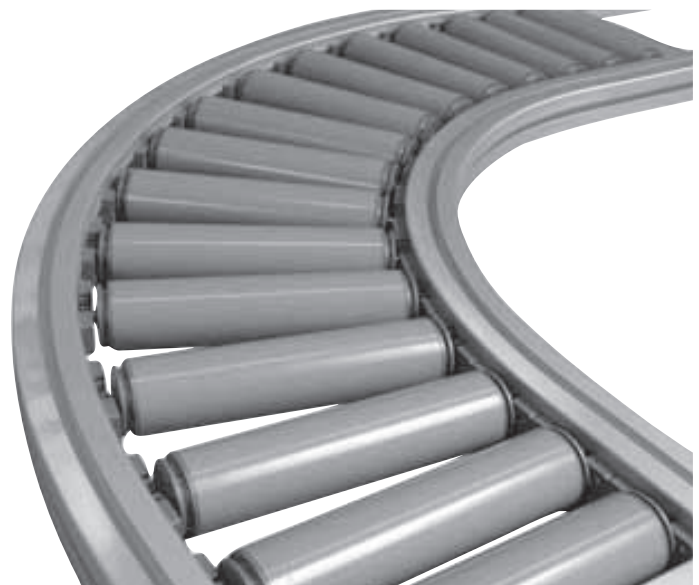

profile	POSITION	MINUTE RADIUS
19 X 45		250
19 X 32		200 500
32 X 32 F		300
45 X 32 F		350 600
45 X 45 F 45 X 45		500
45 X 90 S		750

The MiniTec profile system requires a minimum of processing. The main operations are cutting to length and thread forming, in a few exceptional cases drilling work is necessary.

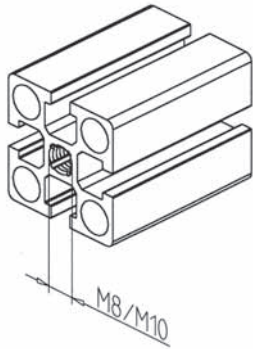

Thread M8 / M10

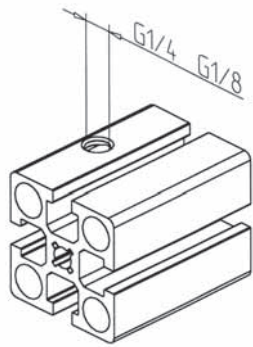

Thread G1/4 G1/8

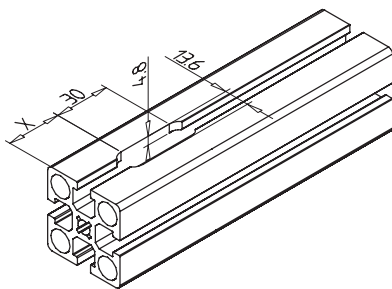

Processing insertion pocket

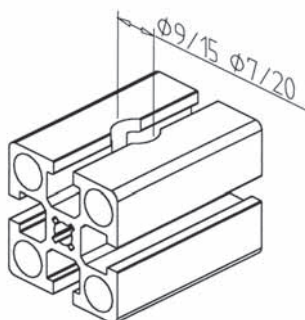

Stepped bore

Thread M8 x 20 part no. 25.1087/0
face in central hole

Thread M10 x 25 part no. 25.1088/0
frontally in central bore for feet

Grew G 1/4 part no. 25.1089/0
on profile surface
for pneumatic connection

Thread G 1/8 part no. 25.1090/0
on profile surface for
pneumatic connection

Thread G 1/4 part no. 25.1091/0
front side in bore \varnothing 11.7 mm
for screw plug, Pneumatic connection

Through hole \varnothing 7 mm part no. 25.1092/0
for screw connection
insert pocket part no. 25.0315/0
on profile surface for subsequent
Assembly of profile connectors

Step drilling \varnothing 9 / \varnothing 15 part no. 25.1085/0
for connector 15 part no. 25.1085/1

Stepped bore \varnothing 7 / \varnothing 20 part no. 25.1097/0
for connection and butt connector

Machining mitre part no. 25.1072/0
for mitre connectors (without cut)

Miter cut part no. 25.1072/1
for mitre connectors
(See chapter connection elements/
miter)

10

10.1745/0 353

17

17.1706/0 284

17.1706/1 284

17.1741/0 304

17.1743/0 306

17.1744/0 354

20

20.0982/0 30

20.0983/0 25

20.0984/0 52

20.0993/0 34

20.0994/0 29

20.0995/0 48

20.0999/0 55

20.1000/0 33

20.1001/0 33

20.1006/0 38

20.1009/0 50

20.1010/0 56

20.1011/0 61

20.1013/0 59, 353

20.1015/0 51

20.1016/0 58

20.1017/0 51, 351

20.1018/0 190

20.1019/0 56, 352

20.1021/0 196

20.1023/0 53

20.1025/0 189

20.1028/0 39

20.1029/0 47

20.1030/0 48

20.1032/0 50

21.1033/0 38

21.0005/0 448
20.1037/0 44

20.0006/0 289

20.0007/0 97

20.0008/0 600

20.0009/0 438

20.0040/0 428

20.0049/0 538

20.0052/0 238

20.0053/0 63, 187

20.0054/0 362

20.0056/0 65, 76

20.0058/0 289

20.0069/0 93

20.0080/0 65, 77

20.0086/0 368

20.0086/0 497

20.0082/0 495, 398

20.0088/0 27

20.0089/0 485

20.0030/0 363187

20.0070/0 236, 399

20.0072/0 485

20.0078/0 60, 386

20.0098/0 507351

20.0099/0 506352

20.0085/0 90

20.0083/0 588

20.0083/0 292

20.0088/0 38

20.0080/0 820

20.0025/0 283

20.0027/0 221

20.0028/0 282

20.0029/0 282

20.0090/0 441

20.0945/0 231

20.0946/0 88, 85

20.0948/0 287

20.0920/0 437

20.0923/0 986

20.0922/0 97

20.0923/0 92

20.0922/0 282

20.0926/0 326

20.0928/0 89

20.0929/0 462

20.0930/0 309

20.0933/0 308

20.0936/0 360

20.0939/0 281

20.0948/0 27

20.0948/0 468

20.0987/0 397

20.0982/0 596

20.0989/0 486

20.0986/0 496

21.0988/0 83

21.0993/0 491

21.0993/1 491

21.0994/1 492

21.0995/0 493

21.1002/0 202

21.1015/0 130

21.1015/1 130

21.1015/2 129

21.1017/0 79

21.1018/0 65

21.1018/1 65

21.1020/0 70, 82

21.1021/0 70, 81

21.1024/0 70, 81

21.1027/0 103

21.1029/0 70, 82

21.1030/0 84

21.1038/0 147

21.1038/6 472

21.1039/0 147

21.1040/0	147	21.1112/0	161	21.1212/1	74
21.1041/0	148	21.1113/0	98	21.1214/0	74
21.1042/0	148	21.1115/0	160	21.1219/0	74
21.1043/0	148	21.1117/1	184	21.1220/0	74
21.1044/0	109	21.1118/0	155	21.1220/1	74
21.1047/0	147	21.1120/0	154	21.1222/0	74
21.1048/0	121	21.1133/0	90	21.1224/0	74
21.1050/7	515	21.1133/6	467	21.1224/1	74
21.1055/0	110	21.1134/0	89	21.1225/0	74
21.1056/0	506	21.1137/0	141	21.1226/0	74
21.1057/0	148	21.1138/0	120	21.1235/0	74
21.1082/0	159	21.1139/0	140	21.1237/0	74
21.1087/3	128	21.1142/0	112	21.1237/1	74
21.1087/4	127	21.1143/0	74	21.1238/0	74
21.1087/6	125	21.1143/1	74	21.1238/1	74
21.1087/7	126	21.1153/0	153	21.1239/0	74
21.1087/8	125	21.1154/0	74	21.1240/0	74
21.1087/9	126	21.1171/0	74	21.1242/0	74
21.1091/3	129	21.1171/1	74	21.1242/1	74
21.1091/4	128	21.1172/0	74	21.1243/0	74
21.1092/1	123	21.1175/0	111	21.1243/1	74
21.1093/0	133	21.1187/0	112	21.1245/0	74
21.1093/1	133	21.1193/0	74	21.1247/0	74
21.1093/2	133	21.1200/0	74	21.1247/1	74
21.1093/3	133	21.1200/1	74	21.1248/0	74
21.1093/4	133	21.1202/0	74	21.1248/1	74
21.1093/5	133	21.1202/2	74	21.1263/0	74
21.1094/1	124	21.1203/0	74	21.1264/0	74
21.1095/0	104	21.1204/0	74	21.1265/0	74
21.1096/0	105	21.1204/1	74	21.1268/0	74
21.1098/0	110	21.1206/0	74	21.1279/0	74
21.1099/1	122	21.1206/1	74	21.1280/0	74
21.1100/0	104	21.1208/0	74	21.1282/0	74
21.1101/0	84	21.1208/1	74	21.1284/0	74
21.1105/0	154	21.1210/0	74	21.1284/1	74
21.1110/0	232	21.1210/1	74	21.1299/0	74
21.1110/2	233	21.1211/0	74	21.1340/1	74
21.1110/3	233	21.1212/0	74	21.1346/0	102

21.1348/0	120	21.1503/0	74	21.1691/0	74
21.1349/0	91	21.1503/1	74	21.1693/0	74
21.1353/0	74	21.1504/0	74	21.1701/0	440
21.1355/0	184	21.1505/0	74	21.1706/0	168
21.1356/0	147	21.1506/0	74	21.1707/0	172
21.1357/0	147	21.1506/1	74	21.1708/1	93
21.1358/0	147	21.1507/0	74	21.1710/1	92
21.1359/0	232	21.1508/0	74	21.1711/0	220
21.1367/0	74	21.1509/0	74	21.1712/0	217
21.1370/0	80	21.1510/0	74	21.1713/0	217
21.1373/0	107	21.1511/0	74	21.1714/0	225
21.1374/0	105	21.1512/0	74	21.1722/0	507
21.1375/0	107	21.1513/0	74	21.1723/0	171
21.1376/0	106	21.1513/1	74	21.1727/0	163
21.1377/0	106	21.1514/0	74	21.1729/0	162
21.1378/0	108	21.1514/1	74	21.1730/0	158
21.1385/0	79	21.1516/0	74	21.1731/0	169
21.1386/0	80	21.1517/0	74	21.1733/0	159
21.1392/0	74	21.1517/1	74	21.1737/0	171
21.1397/0	94	21.1518/0	74	21.1738/0	170
21.1397/6	467	21.1519/0	74	21.1740/0	143
21.1399/0	99	21.1520/0	74	21.1741/0	143
21.1400/0	68, 86	21.1523/0	74	21.1748/0	136
21.1401/0	68, 85	21.1532/0	74	21.1752/0	124
21.1403/0	101	21.1537/0	74	21.1753/0	142
21.1404/0	99	21.1543/0	74	21.1755/0	132
21.1407/0	100	21.1546/0	74	21.1757/0	140
21.1411/0	70, 87	21.1547/0	74	21.1758/0	141
21.1472/0	102	21.1550/0	74	21.1759/0	145
21.1472/6	464	21.1552/0	74	21.1759/1	146
21.1473/0	103	21.1557/0	74	21.1760/0	142
21.1475/0	155	21.1566/0	74	21.1761/0	167
21.1476/0	157	21.1571/0	74	21.1762/0	168
21.1482/0	74	21.1591/0	74	21.1763/0	139
21.1500/0	74	21.1595/0	74	21.1766/0	234
21.1501/0	74	21.1645/0	74	21.1767/0	131
21.1501/1	74	21.1662/0	74	21.1772/0	223
21.1502/0	74	21.1666/0	63	21.1774/0	215

21.1775/0	212	21.1862/0	150	21.2030/0	114
21.1776/0	212	21.1863/0	150	21.2034/0	116
21.1777/0	213	21.1864/0	150	21.2041/0	117
21.1778/0	224	21.1868/0	74	21.2058/0	156
21.1780/0	213	21.1871/0	149	21.2059/0	156
21.1781/0	228	21.1872/0	149	21.2068/0	87
21.1782/0	228	21.1873/0	149	21.2077/0	88
21.1783/0	165	21.1874/0	149	21.2078/0	88
21.1784/0	166	21.1877/0	74	21.2078/6	466
21.1788/0	134	21.1879/0	569	21.2105/0	113
21.1788/2	134	21.1881/0	149	21.2106/0	113
21.1788/3	134	21.1882/0	149	21.2109/0	92
21.1788/4	134	21.1883/0	149	21.2110/0	166
21.1788/5	134	21.1884/0	149	21.2111/0	114
21.1788/6	134	21.1890/0	68, 86	21.2113/0	101
21.1792/0	214	21.1891/0	149	21.2114/0	147
21.1795/0	226	21.1892/0	149	21.2115/0	147
21.1796/0	224	21.1893/0	149	21.2116/0	147
21.1797/0	214	21.1894/0	149	21.2120/0	164
21.1798/0	134	21.1945/0	74	21.2123/0	74
21.1798/2	134	21.1945/1	74	21.2127/0	74
21.1798/3	134	21.1946/0	74	21.2134/0	74
21.1798/4	134	21.1947/0	74	21.2156/0	74
21.1798/5	134	21.1948/0	74	21.2191/0	169
21.1798/6	134	21.1949/0	74	21.2195/0	74
21.1799/0	225	21.1950/0	74	21.2199/0	95
21.1817/0	193	21.1951/0	74	21.2210/0	167
21.1819/0	569	21.1980/0	218	21.2215/0	74
21.1834/0	192	21.1981/0	218	21.2219/0	74
21.1838/0	215	21.1982/0	219	21.2219/1	74
21.1839/0	216	21.1983/0	219	21.2220/0	183
21.1840/0	216	21.2000/0	229	21.2230/0	117
21.1842/0	150	21.2002/0	231	21.2236/1	74
21.1843/0	150	21.2003/0	230	21.2250/0	505
21.1844/0	150	21.2010/0	115	21.2300/0	165
21.1851/0	149	21.2017/0	74	21.2301/0	146
21.1852/0	149	21.2019/0	230	21.2305/0	127
21.1853/0	192	21.2020/0	115	21.2308/0	144

21.2311/0	138
21.2315/0	116
21.2316/0	139
21.2317/0	121
21.2323/0	138
21.2503/1	93
21.2505/0	164
21.2506/0	151
21.2510/0	149
21.2511/0	149
21.2512/0	149
21.2513/0	149
21.2524/0	152
21.2525/0	152
21.2530/1	123
21.2532/0	111

22

22.0978/1	63
22.0979/1	63
22.0981/1	63
22.0982/1	63
22.0983/1	63
22.0991/0	200
22.0992/1	63
22.0993/1	63
22.0994/1	63
22.0995/1	63
22.0996/1	63
22.0996/2	63
22.1001/1	63
22.1002/1	63
22.1003/1	63
22.1004/1	63
22.1007/1	63
22.1008/2	63
22.1009/1	63
22.1010/0	195
22.1011/0	203

22.1014/1	63
22.1016/0	447
22.1017/1	63
22.1017/2	63
22.1018/1	63
22.1018/2	63
22.1019/1	63
22.1019/2	63
22.1021/1	63
22.1022/0	447
22.1025/1	172
22.1038/0	203
22.1039/0	188
22.1040/0	209
22.1041/0	210
22.1045/0	240
22.1046/1	63
22.1048/1	63
22.1049/1	63
22.1052/1	63
22.1056/0	63
22.1057/1	63
22.1058/1	63
22.1059/1	63
22.1060/2	63
22.1062/2	63
22.1064/2	63
22.1065/2	63
22.1067/2	63
22.1067/5	63
22.1068/2	63
22.1073/1	200
22.1075/1	201
22.1076/0	189
22.1077/0	201
22.1078/0	202
22.1079/0	227
22.1081/0	198

22.1082/0	244
22.1083/0	198
22.1084/0	244
22.1085/0	205
22.1086/1	199
22.1087/0	209
22.1089/0	207
22.1090/1	190
22.1092/0	191
22.1094/0	342
22.1095/0	342
22.1096/0	343
22.1099/0	199
22.1104/0	207
22.1107/1	191
22.1116/1	237
22.1117/1	237
22.1118/1	238
22.1119/1	235
22.1120/1	235
22.1121/1	236
22.1134/1	63
22.1135/0	208
22.1136/1	63
22.1137/1	63
22.1140/0	96
22.1144/1	63
22.1146/1	63
22.1148/0	227
22.1149/2	63
22.1150/0	428
22.1151/0	441
22.1152/0	442
22.1154/1	239
22.1156/0	238
22.1158/0	188
22.1162/1	63
22.1164/0	170

22.1167/1	63
22.1168/1	63
22.1169/1	63
22.1170/0	205
22.1171/0	208
22.1174/0	197
22.1175/0	398
22.1181/0	151
22.1182/1	63
22.1183/1	63
22.1184/0	226
22.1185/0	204
22.1190/0	508
22.1196/0	508
22.1200/1	63
22.1201/1	63
22.1202/1	63
22.1204/0	241
22.1208/1	63
22.1209/1	63
22.1210/0	242
22.1212/0	240
22.1213/0	410
22.1215/1	63
22.1216/0	241
22.1217/0	153
22.1220/1	63
22.1230/0	179
22.1235/0	179
22.1240/0	180
22.1245/0	180
22.1250/0	181
22.1255/0	181
22.1260/0	182
22.1265/0	182
22.1270/0	242

23

23.0010/0	560
-----------	-----

23.0011/0	560
23.0060/0	559
23.0102/0	554
23.0103/0	554
23.0104/0	554
23.0105/0	554
23.0106/0	555
23.0107/0	555
23.0108/0	555
23.0109/0	554
23.0112/0	554
23.0113/0	554
23.0114/0	554
23.0115/0	554
23.0116/0	555
23.0117/0	555
23.0118/0	555
23.0119/0	554
23.1404/0	559

24

24.1104/0	257
24.1105/0	256
24.1105/2	256
24.1105/3	256
24.1105/7	258
24.1106/0	256
24.1106/2	256
24.1106/3	256
24.1106/7	259
24.1107/0	256
24.1107/2	256
24.1107/3	256
24.1109/0	257
24.1110/0	258
24.1116/0	63
24.1117/0	63
24.1118/0	63
24.1126/0	118

24.1127/0	118
24.1128/0	119
24.1201/0	259
24.1205/0	260
24.1210/0	260

26

26.0800/0	581
26.0811/0	585
26.0813/0	583
26.0814/0	585
26.0815/0	583
26.0818/0	584
26.1050/0	579
26.1056/0	579
26.1060/0	580
26.1063/0	578
26.1065/0	577
26.1082/0	580
26.1092/0	578
26.1101/0	173
26.1150/0	584
26.1814/0	575
26.1820/0	575
26.1910/0	582
26.1970/0	582
26.3001/0	425
26.3001/1	426
26.3001/2	427
26.3002/0	427
26.3004/0	426

27

27.0118/1	262
27.0118/2	262
27.0118/3	262
27.0118/4	262
27.0118/5	262
27.0118/6	262

27.0119/1	262	27.0125/3	262	27.0131/5	262
27.0119/2	262	27.0125/4	262	27.0131/6	262
27.0119/3	262	27.0125/5	262	27.0132/1	262
27.0119/4	262	27.0125/6	262	27.0132/2	262
27.0119/5	262	27.0126/1	262	27.0132/3	262
27.0119/6	262	27.0126/2	262	27.0132/4	262
27.0120/1	262	27.0126/3	262	27.0132/5	262
27.0120/2	262	27.0126/4	262	27.0132/6	262
27.0120/3	262	27.0126/5	262	27.0133/1	262
27.0120/4	262	27.0126/6	262	27.0133/2	262
27.0120/5	262	27.0127/1	262	27.0133/3	262
27.0120/6	262	27.0127/2	262	27.0133/4	262
27.0121/1	262	27.0127/3	262	27.0133/5	262
27.0121/2	262	27.0127/4	262	27.0133/6	262
27.0121/3	262	27.0127/5	262	27.0134/1	262
27.0121/4	262	27.0127/6	262	27.0134/2	262
27.0121/5	262	27.0128/1	262	27.0134/3	262
27.0121/6	262	27.0128/2	262	27.0134/4	262
27.0122/1	262	27.0128/3	262	27.0134/5	262
27.0122/2	262	27.0128/4	262	27.0134/6	262
27.0122/3	262	27.0128/5	262	27.0135/1	262
27.0122/4	262	27.0128/6	262	27.0135/2	262
27.0122/5	262	27.0129/1	262	27.0135/3	262
27.0122/6	262	27.0129/2	262	27.0135/4	262
27.0123/1	262	27.0129/3	262	27.0135/5	262
27.0123/2	262	27.0129/4	262	27.0135/6	262
27.0123/3	262	27.0129/5	262	27.0136/1	262
27.0123/4	262	27.0129/6	262	27.0136/2	262
27.0123/5	262	27.0130/1	262	27.0136/3	262
27.0123/6	262	27.0130/2	262	27.0136/4	262
27.0124/1	262	27.0130/3	262	27.0136/5	262
27.0124/2	262	27.0130/4	262	27.0136/6	262
27.0124/3	262	27.0130/5	262	27.0137/1	262
27.0124/4	262	27.0130/6	262	27.0137/2	262
27.0124/5	262	27.0131/1	262	27.0137/3	262
27.0124/6	262	27.0131/2	262	27.0137/4	262
27.0125/1	262	27.0131/3	262	27.0137/5	262
27.0125/2	262	27.0131/4	262	27.0137/6	262

28

28.0001/0	318	28.0082/2	326	28.0152/0	347
28.0002/0	305	28.0082/3	326	28.0153/0	350
28.0004/1	320	28.0082/4	326	28.0154/0	355
28.0004/3	321	28.0082/5	326	28.0155/0	346
28.0005/0	319	28.0082/6	326	28.0156/0	347
28.0006/0	298	28.0082/7	326	28.0157/0	349
28.0007/1	298	28.0084/0	313	28.0158/0	119
28.0007/2	299	28.0087/0	313	28.0159/0	349
28.0008/0	301	28.0087/3	314	28.0170/0	337
28.0009/0	297	28.0088/0	311	28.0173/0	279
28.0010/0	297	28.0089/0	311	28.0174/0	280
28.0011/1	302	28.0090/0	286	28.0175/0	280
28.0011/2	302	28.0091/0	312	28.0178/0	345
28.0012/1	299	28.0092/0	312	28.0179/0	345
28.0012/2	300	28.0093/0	286	28.0180/0	285
28.0013/1	300	28.0094/1	355	28.0181/0	332
28.0013/2	301	28.0095/1	357	28.0182/0	333
28.0019/0	306	28.0101/1	356	28.0183/0	332
28.0021/0	319	28.0102/1	356	28.0185/0	335
28.0022/0	320	28.0103/1	357	28.0186/0	334
28.0026/0	83	28.0119/0	296	28.0187/0	333
28.0045/0	326	28.0120/0	245	28.0188/0	334
28.0045/2	326	28.0121/0	245	28.0192/0	339
28.0045/3	326	28.0122/0	246	28.0193/0	339
28.0045/4	326	28.0127/0	309	28.0196/0	338
28.0045/5	326	28.0132/0	341	28.0197/0	338
28.0045/6	326	28.0133/0	341	28.0248/0	315
28.0045/7	326	28.0136/0	340	28.0249/0	316
28.0049/0	321	28.0137/0	340	28.0264/0	278
28.0051/0	287	28.0138/0	309	28.0265/0	279
28.0052/0	305	28.0138/1	310	28.0270/0	322
28.0054/0	317	28.0138/2	310	28.0350/0	328
28.0055/0	317	28.0140/0	308	28.0351/0	330
28.0056/0	316	28.0143/0	348	28.0352/0	329
28.0057/0	318	28.0144/0	350	28.0353/0	330
28.0082/0	326	28.0146/0	354	28.0354/0	328
28.0082/1	327	28.0150/0	346	28.0355/0	337
		28.0151/0	348	28.0359/0	329

28.0371/0	331
28.0386/0	287
28.0500/0	274
28.0501/0	274
28.0502/0	285
28.0503/0	275
28.0504/0	275
28.0509/0	325
28.0509/1	325
28.0509/2	325
28.0509/3	325
28.0510/0	325
28.0510/1	325
28.0510/2	325
28.0510/3	325
28.0520/0	308
28.0525/0	296
28.0600/0	276
28.0601/0	276
28.0614/0	325
28.0614/1	327
28.0614/2	325
28.0614/3	325
28.0614/4	325
28.0614/5	325
28.0614/6	325
28.0615/0	325
28.0615/2	325
28.0615/3	325
28.0615/4	325
28.0615/5	325
28.0615/6	325
28.0800/0	277
28.0801/0	278
28.0802/0	277
28.0808/0	307
28.0809/0	307
28.0810/0	314

28.0811/0	315
28.0813/0	324
28.0814/0	323
28.0815/0	323
28.0820/0	303
28.0821/0	304
28.0822/0	303
28.1000/0	267
28.1000/1	267
28.1000/2	267
28.1001/0	267
28.1002/0	267
28.1002/1	267
28.1002/2	267

29

29.0022/0	424
29.0111/0	410
29.0307/0	221
29.0402/0	231
29.0851/0	458
29.0852/0	457
29.5001/0	501
29.5002/0	502
29.5010/0	502
29.5019/0	482
29.5019/1	482
29.5019/2	482
29.5019/3	482
29.5019/4	482
29.5019/5	482
29.5019/6	482
29.5019/7	482
29.5019/8	482
29.5019/9	482
29.5022/0	494
29.5023/1	493
29.5025/0	509
29.5028/0	510

29.5031/0	495
29.5034/0	513
29.5035/0	498
29.5036/0	499
29.5037/0	500
29.5040/0	499
29.5042/0	494
29.5046/0	511
29.5047/0	512
29.5048/0	512
29.5049/0	514
29.5051/0	514
29.5052/0	513
29.5055/0	510
29.5056/0	511
29.5057/0	482
29.5060/0	498
29.5069/0	497
29.5280/0	501
29.5310/0	500
29.8012/0	206

32

32.0024/0	425
32.0053/0	408
32.0111/0	363
32.0111/1	363
32.0111/2	363
32.0111/3	363
32.0111/4	363
32.0112/0	363
32.0112/1	363
32.0112/2	363
32.0112/3	363
32.0112/4	363
32.0113/0	363
32.0113/1	363
32.0113/2	363
32.0113/3	363

32.0155/0	434	32.0541/5	400	32.0771/0	430
32.0160/0	434	32.0542/0	400	32.0772/0	430
32.0165/0	435	32.0542/5	400	32.0773/0	429
32.0201/0	415	32.0543/0	400	32.0774/0	429
32.0220/0	411	32.0543/5	400	32.0801/0	384
32.0222/0	412	32.0545/0	411	32.0806/0	378
32.0223/0	412	32.0547/0	423	32.0807/0	382
32.0224/0	413	32.0550/0	443	32.0808/0	382
32.0225/0	414	32.0553/0	446	32.0809/0	378
32.0226/0	413	32.0554/0	446	32.0810/0	379
32.0230/0	414	32.0560/0	443	32.0811/0	379
32.0306/0	415	32.0562/0	449	32.0812/0	380
32.0335/0	372	32.0569/0	445	32.0813/0	380
32.0360/0	372	32.0571/0	449	32.0814/0	381
32.0405/0	193	32.0572/0	448	32.0819/0	381
32.0406/0	193	32.0574/0	445	32.0876/0	403
32.0410/0	374	32.0575/0	444	32.0877/0	403
32.0440/0	374	32.0575/1	444	32.0901/0	438
32.0460/0	375	32.0580/0	437	32.1001/0	461
32.0490/0	374	32.0581/0	437	32.1002/0	460
32.0501/0	406	32.0583/0	438	32.1003/0	461
32.0502/0	428	32.0586/0	440	32.1004/0	460
32.0507/0	424	32.0601/0	420	32.1007/0	464
32.0512/0	406	32.0602/0	421	32.1011/0	469
32.0514/0	401	32.0605/0	409	32.1013/0	463
32.0516/0	401	32.0608/0	419	32.1017/0	462
32.0517/0	407	32.0609/0	420	32.1018/0	462
32.0518/0	407	32.0610/0	409	32.1021/0	469
32.0533/0	418	32.0615/0	421	32.1030/0	470
32.0534/0	419	32.0616/0	422	32.1031/0	470
32.0535/0	418	32.0617/0	422	32.1034/0	471
32.0536/0	417	32.0618/0	423	32.1035/0	471
32.0537/0	417	32.0703/0	431	32.1036/0	472
32.0538/0	416	32.0704/0	432	32.1169/0	388
32.0539/0	416	32.0705/0	432	32.1170/0	388
32.0540/0	400	32.0706/0	433	32.1171/0	388
32.0540/5	400	32.0769/0	463	32.2005/1	457
32.0541/0	400	32.0770/0	431	32.2010/0	456

32.2011/0	456
-----------	-----

32.4110/0	374
-----------	-----

32.4120/0	374
-----------	-----

32.4140/0	374
-----------	-----

32.4160/0	374
-----------	-----

32.4200/0	374
-----------	-----

32.4210/0	374
-----------	-----

32.4220/0	374
-----------	-----

32.4240/0	374
-----------	-----

32.4260/0	374
-----------	-----

32.4410/0	374
-----------	-----

32.4420/0	374
-----------	-----

32.4440/0	374
-----------	-----

32.4460/0	374
-----------	-----

32.4610/0	375
-----------	-----

32.4620/0	375
-----------	-----

32.4640/0	375
-----------	-----

32.4660/0	375
-----------	-----

32.4700/0	374
-----------	-----

32.4710/0	374
-----------	-----

32.4720/0	374
-----------	-----

32.4740/0	374
-----------	-----

32.4760/0	374
-----------	-----

32.4910/0	374
-----------	-----

32.4920/0	374
-----------	-----

32.4940/0	374
-----------	-----

32.4960/0	374
-----------	-----

32.6000/0	375
-----------	-----

32.6010/0	375
-----------	-----

32.6020/0	375
-----------	-----

32.6040/0	375
-----------	-----

32.6060/0	375
-----------	-----

32.6100/0	375
-----------	-----

32.6110/0	375
-----------	-----

32.6120/0	375
-----------	-----

32.6140/0	375
-----------	-----

32.6160/0	375
-----------	-----

32.6204/0	375
-----------	-----

32.6208/0	375
-----------	-----

33

33.0015/0	250
-----------	-----

33.0016/0	250
-----------	-----

33.0017/0	250
-----------	-----

33.0018/0	250
-----------	-----

33.0019/0	250
-----------	-----

33.0020/0	250
-----------	-----

33.0021/0	250
-----------	-----

33.0023/0	250
-----------	-----

33.0080/0	251
-----------	-----

33.0080/1	251
-----------	-----

33.0081/0	251
-----------	-----

33.0081/1	251
-----------	-----

33.0082/0	251
-----------	-----

33.0082/1	251
-----------	-----

33.0083/0	251
-----------	-----

33.0083/1	251
-----------	-----

33.0084/0	251
-----------	-----

33.0084/1	251
-----------	-----

33.0085/0	251
-----------	-----

33.0085/1	251
-----------	-----

33.0086/0	250
-----------	-----

33.0087/0	250
-----------	-----

33.0088/0	250
-----------	-----

33.0089/0	250
-----------	-----

33.0090/0	250
-----------	-----

33.0091/0	250
-----------	-----

33.0092/0	250
-----------	-----

33.0093/0	250
-----------	-----

33.0410/0	243
-----------	-----

33.0411/0	243
-----------	-----

33.3007/0	281
-----------	-----

33.3008/0	282
-----------	-----

33.3009/0	283
-----------	-----

33.3010/0	281
-----------	-----

33.3011/0	282
-----------	-----

33.3012/0	283
-----------	-----

35

35.0041/0	450
-----------	-----

43

43.0010/0	526
-----------	-----

43.0011/0	527
-----------	-----

43.0020/0	526
-----------	-----

43.0030/0	527
-----------	-----

43.0040/0	528
-----------	-----

43.0050/0	528
-----------	-----

43.0060/0	529
-----------	-----

43.0071/0	531
-----------	-----

43.0073/0	530
-----------	-----

43.0080/0	533
-----------	-----

43.0090/0	530
-----------	-----

43.0100/0	532
-----------	-----

43.0110/0	532
-----------	-----

43.1000/0	531
-----------	-----

43.1411/0	533
-----------	-----

43.1510/0	529
-----------	-----

50

50.0128/0	516
-----------	-----

50.1726/0	322
-----------	-----

56

56.0011/0	567
-----------	-----

56.0012/0	567
-----------	-----

56.0013/0	567
-----------	-----

56.0021/0	567
-----------	-----

56.0022/0	567
-----------	-----

56.0023/0	567
-----------	-----

56.0031/0	567
-----------	-----

56.0032/0	567
-----------	-----

56.0033/0	567
-----------	-----

56.0041/0	567
-----------	-----

56.0042/0	567
-----------	-----

56.0043/0	567
-----------	-----

56.0051/0	567
-----------	-----

56.0052/0	567
56.0053/0	567
56.0061/0	567
56.0062/0	567
56.0063/0	567
56.0071/0	567
56.0072/0	567
56.0073/0	567
56.0081/0	567
56.0082/0	567
56.0083/0	567
56.0091/0	567
56.0092/0	567
56.0093/0	567
56.0101/0	567
56.0102/0	567
56.0103/0	567
56.0111/0	567
56.0112/0	567
56.0113/0	567
56.0121/0	567
56.0122/0	567
56.0123/0	567

E9

E9.0141/0	465
-----------	-----

P2

P2.0060/0	458
-----------	-----

A

Actuating Bow for security switch B2	233
Actuating bow for security switch B3	233
ADAPTER G32 / 30 x 30	97
ADAPTER G32 / G32	97
Adapter 30 x 30 / G32	98
Adapter cap connector strip for cable duct 45 AL	239
Adapter flange 30	164
Adapter flange 45	165
Adapter for tool case	427
Additional angle for viewing compartment	423
Adjusting Unit VEN 45x90S	333
Adjusting Unit VEW 45x90 F	332
Adjusting Unit VEW 45x90 H	333
Adjusting Unit VEN 45x90 H	335
Adjusting unit VEN 45x90	334
Adjusting unit VEN 90	334
Adjusting unit VEW 90	332
ANGULAR Profile 89 X 89	61
ANODISING POLISHER	585
Angle 90° for cable duct 45 AL	238
Angle console for mini-adjusting unit	331
Angle-sheet SST	96
Angular slide rail 30	208
Angular slide rail 45	209
Attachment clip 16	416
Attachment clip 8	417
Autom. hose reel	438
B	
BALL LATCH SUPPORT 50	140
BALL LATCH SUPPORT 70	141
Balancer	410
Ball bearing LME 20 UU	353

Ball bearing LR 12	318
Ball bearing LR 12 L	319
Ball bearing LR 16	322
Ball catch 50	139
Ball catch 70	140
Ball head M8	151
Ball roller	450
Base and transport plate 90 x 90 x 45	164
Base frame 200	527
Base set tool case	426
Basic module 200	526
Basic module VARIABLE	527
Basic track	526
Beam 180	166
Beam 90	165
Bellow LR 180	283
Bellow LR 45	281
Bellow LR 90	282
Belt drive 45	315
Belt drive 90	316
Belt tensioning cylinder 45 ST	492
Belt tensioning cylinder 90	496
Bolt concentric LR 16	323
Bolt connector 15	81
Bolt connector 20	81
Bracket for miniature roller strip 19	444
Bracket for miniature roller strip 30	444
Brake plate	449
Brake roller PVC 50	505
Brush strip 30	428
Butt connector 20	82
bottles/drink carton holder	424

C

CABLE CLAMP	214	Clamping block 23	179
Cable	213	Clamping block 30	179
Cable Clip 27-30	240	Clamping block 32	180
Cable Clip 45	242	Clamping block 45	180
Cable clamp 45	242	Clamping claw	103
Cable clip 27-45	241	Clamping profile 32 X 32	35, 187
Cable duct 27 AL	234	Clamping profile 45 X 32	37, 187
Cable duct 32	244	Clamping profile 45 x 45 F	39
Cable duct 45	244	Clamping profile PVC	191
Cable duct 45 AL	236	Clip - Block for ball head	151
Cable duct 90 AL	239	Closure cap for C-rail	412
Cable Pulley 45	212	Clutch 20	285
Cable Pulley 90	212	COUNTERWEIGHT 45	223
Cable trolleys for round cables	414	COUNTERWEIGHT 90	224
Cantilever foot 175	169	Combi L-key	576
Cap cable duct 45 AL	237	Connecting bar	98
Carrier profile 45 R	442	Connecting plate 30 x 60	101
Catch 32 for handle profile	448	Connecting plate 45 x 45 VA M10	156
Center drive conveyor belt	501	Connecting plate 45 x 90	102
Centering bushing	354	Connecting plate 45x90, conductive	464
Central earthing box ESD	461	Connecting plate 60 x 60 x 30	163
Chain 04	217	Connecting plate 90 x 32	102
Chain 08	221	Connecting plate 90 x 90	103
Chain clamping 90 S carriage	222	Connecting shaft 45	284
Chain clamping weight	220	Connecting shaft 90	284
Chain clamping weight S	223	Connection plate 45x90 M10 conductive	472
Chain Pulley 90 S	220	Container Holder 32-400	415
Chain pulley 32	215	Conveyor roller D 25	440
Chain pulley 45 A	215	Corner Connection 90 R 90°	95
Chain pulley 45 I	216	Cover Profile 45	204
Chain pulley 90	216	Cover Profile L	196
Clamp 27-45 C	241	Cover profile 30	194, 204
Clamp holder 10	513	Cover profile 45 x 45 R	44

Cover profile G	195
Cover profile K	195
Cover profile LR	321
Cover supporting foot 45	170
Cover supporting foot 90	172
Cross-connector 45	78
CURVE 90° RIGHT / LEFT	528
Cup holder	423
Curve 200 - 180° right	529
C-section rail 30	411
D	
DEBURRING TOOL	583
DETACHABLE HINGE 19	104
DETACHABLE HINGE 32	104
DETACHABLE HINGE 45	105
DETACHABLE HINGE L 19/19	107
DETACHABLE HINGE L 19/30	105
DETACHABLE HINGE L 19/45	107
DETACHABLE HINGE L 30/30	106
DETACHABLE HINGE L 30/45	106
DETACHABLE HINGE L 45/45	108
Deadbolt 32 with allen wrench SW 10	125
Deadbolt 32 with square key SW 7	125
Deadbolt 45 with allen wrench SW 10	126
Deadbolt 45 with square key SW 7	126
DISTANCE Profile 30	188
Distance profile	188
Document bar	409
Document clip	420
Document support	409
Door catch 19	132
Door catch S	131
Door chain clamping 90 S, at the front	221

Door chain clamping 90 S, on the side	222
Door chain clamping device	217
Door chain clamping device KI-32	219
Door chain clamping device KI-45	219
Door chain clamping device KV-32	218
Door chain clamping device KV-45	218
Door hinge large	109
Door hinge small	108
Door lock	136
Door SG 1000 WG	559
Doors Base cabinet small	383
Doors base cabinet large	383
Double panel clamping profile	190
Double slide rail	209
Drawer base cabinet 100/200	379
Drawer base cabinet 100/200/200	381
Drawer base cabinet 150/150	379
Drawer base cabinet 200	378
Drawer base cabinet 50/100/150	380
Drawer base cabinet 50/100/150/200	381
Drawer cabinet 100/100/100	380
Drawer container set 1	382
Drawer container set 2	382
Drawing holder	419
Drilling jig	578
Drilling jig 30	577
Drilling jig for mitre 30	578
Drilling jig for mitre 45	579
Drilling jig for mitre N 45	580
Drilling jig for mitre N30	579
Drive belt PU	515
Drive belt NBR	515
Drive drum 45 ST	493

Drive drum 45 ST for motor attachment KIT 45	494	End cap for cable duct 90 AL	240
Drive drum 45 ST for plug-on motor D16	493	End cap LR 16	323
Drive drum 45ST for plug-on motor D20	494	End stop C-rail	413
Drive drum 90	497	End stop miniature roller strip	445
Drive drum 90 for Engine mounting KIT 90	497	Energy Chain R	243
Drive drum 90 L for plug-on motor D20	498	Expanded base frame 200	528
Drum bearing 45	491		
Drum bearing 45 with bore	491	F	
Drum bearing 45 - 20	492	Fastening for bellow LR 180	283
Drum bearing 90	495	Fastening for bellow LR 45	281
Drum bearing 90 with bore	496	Fastening for bellow LR 90	282
Dummy plug without resistor	461	Fastening kit 19 for protective fields	560
		Fastening kit 45 S-A 180°	280
E		Fastening kit 45 S-A 90°	280
Earth conductor ESD	460	Fastening kit 90 S-A 180°	279
Earthing box ESD	460	Fastening kit 90 S-A 90°	279
Earthing cable ESD area	463	Fastening kit 90 S-S	278
Earthing clamp	465	Fastening kit for SG fields with captive screw	560
Earthing point	463	Fastening kit for timing belt tensioner 45	317
Eccentric bushing LR 16	324	Fastening kit for timing belt tensioner 45 x 90 F	317
Edge Protection	197	Fastening kit for timing belt tensioner 45 x 90 H	316
Edge Protection for cable duct 27 AL	235	Fastening kit for timing belt tensioner 90	318
Edge protection	448	Fastening kit LRE	320
Edging and cover profile	194	Fastening kit LRK	319
Elastic wrist strap	462	Fastening plate 45 SST to fixed castor	156
Emergency release for latch lock	139	Fastening plate 90 to fixed castor	157
END CAP LB 180	357	Fastening set floor cabinet	378
END CAP LB 45	355	Filter regulator and manual start-up valve	437
END CAP LB 45 x 135	356	Fixed castor D 75 x 103	155
END CAP LB 45 x 180	356	Fixed castor D100 x 135, ESD	472
END CAP LB 90	357	Flange bearing 32	447
End Cap LR (Left)	321	Flat pliers	585
End Cap LR (Right)	320	Floor anchor 10	159
End cap cable duct 27 AL	235	Floor anchor 12	160

Floor mounting angle	161, 162
Floor mounting plate 45	158
Floor mounting plate 45x45 G	153
Floor mounting plate 90	159
FOLDING HINGE 19 S	109
FOLDING HINGE 32 S	110
FOLDING HINGE 45 M6	111
FOLDING HINGE 45 S	110
Folding doorway set	227
Folding hinge 30 GD	111
Foot 30 compact	152
Foot 45 compact	152
Foot D45 conductive	469
Foot D80 conductive	469
Foot rest comfort	435
Foot rest ECO	434
Foot rest Standard	434
Furniture wheel with locking device	153
Furniture wheel without locking device	154

G

Gas pressure spring 10/22	119
Gas pressure spring 6 / 15	118
Gas pressure spring 8 / 20	118
Glide roll element	225
Glide roll element parallel	225
Grip profile clamp 32	447
Groove deburring	584
Groove opener	583
Guide for Sliding Door 30 V	226
Guide for sliding door 45	227
Guide Profile 2	200
Guide profile 3	201

H

HANDLE 120 ESD, black	464
HANDLE AL	120
HANDLE Profile 32	61
Hammer screw	80
Hand grip with reach protector	121
Hand protection	213
Handle 120	123
Handle 135	123
Handle 180	124
Handle 90	122
Handle AL angled	120
Handle bar 32	122
Handle GP	121
Handle profile aluminium	60
Heavy duty joint 45	116
Height setting for worktable	372
Horizontal double outlet	429

I

Inner angle cable duct 27 AL	236
Inside angle cable duct 45 AL	238
Interlock sliding door K	230
Intermediate plate	502
Internal hinge AL	112
Inward transfer 200	531

J

Joint 30 F	114
Joint 30 F/S	113
Joint 30 S	113
Joint 45 R	117
Joint 45 R with star grip	117

K

KanTainer-swivel cantilever, 3-fold	403
Kantainer - shelf (straight)	403
Keyboard storage	407
Knife edge 16	500

L

Lateral guide 140 Support S	510
Lateral guide 140 support	510
Lateral guide 70 Support	509
Lateral guide 70 Support S	511
Lateral guide conveyor belt	513
Lateral guide F	514
Lateral guide support U-shaped	512
Lateral guide support, long	512
Lateral guide support, short	511
Leveling plate 180 ST	161
Leveling plate 90 ST	160
LIFT STATION	533
LIFT STATION 200	532
Linear axis LR 16 - 45x90	277
Linear axis LR 16 - 90x180	278
Linear axis LR 16 - 90x90	277
Linear axis LR 6 Z compact - 45x45R	275
Linear axis LR 6 Z compact - 45x90	275
Linear axis LR 6 Z-45x45R	274
Linear axis Z LR 6 - 45x90	274
Linear axis LR 12 - 45x90	276
Linear axis LR 12 - 90x90	276
Linear module LB 180	345
Linear module LB 90	345
Lock cylinder	124
Lock plate for door lock	136
Locking bolt adjustment F	457
Locking bolt adjustment H	458

Lubricator	437
------------	-----

M

Magnet 6 x 14 x 50	145, 398
Magnet 6 x 9 x 50 mm	144, 399
Magnet plate S	144
Magnetic bit holder Torx	575
Magnetic catch	142
Magnetic catch N	143
Magnetic catch S	143
Mini Adjusting Unit with Profile 45x19	329
Miniature roller strip bracket F	446
Miniature roller strip with miniature flange rollers	443
Miniature roller brake	449
Miniature roller strip bracket H	446
Miniature roller strip with cyl. Miniature roller	443
Mini-adjusting unit mounting kit	328
Mini-adjusting unit with handle profile 32	330
Mini-adjusting unit with profile 19x32	330
Mini-adjusting unit with profile 19x45	329
Mini-adjusting unit with profile 45x45	328
Mitre Connector N 45	85
Mitre connector 30	86
Mitre connector 45	86
Mitre connector N 30	85
MONITOR CARRIER V 100	408
Monitor support with keyboard tray TFT	407
Motor mounting KIT 90	498
Motor mounting kit 45 Ø 20 mm	495
Mounting angle 16 GD-Z	88
Mounting angle 19 GD-Z	88
Mounting angle 19 GD-Z conductive	466
Mounting angle 25 GD-Z	89
Mounting angle 25 GD-Z conductive	466

Mounting angle 25 S	89
Mounting angle 30 GD	90
Mounting angle 30 GD-Z conductive	468
Mounting angle 30 R 90°	92
Mounting angle 45 G	93
Mounting angle 45 GD	90
Mounting angle 45 GD-Z	91
Mounting angle 45 GD-Z, conductive	467
Mounting angle 45 R 90°	92
Mounting angle 45 SST	91
Mounting angle 45 x 90 GD-Z	94
Mounting angle 45 x 90 GD-Z, conductive	467
Mounting angle 45°	93
Mounting angle 90 GD-Z	94
Mounting angle 90 GD-Z conductive	468
Mounting angle bracket for safety switch	232
Mounting base F pivoted	185
Mounting base N pivoted	185
Mounting block	416
Mounting bracket 30	87
Mounting bracket 45	87
Mounting brackets for energy chain R	243
MULTIBLOCK 30 GD	183
MULTIBLOCK GD	184
Multi connector 30	96
O	
Outward transfer 200	530
P	
PANEL CLAMPING Profile	189
Pan head screw M6	183
Panel framing profile	191
Panel holder grey	190

Parallel slide rail	210
Pipe 50 x 2	505
Pistol form impulse wrench	581
Plug G1/4"	257
Plug seal 2	198
Plug seal 30	197
Plug seal 4	198
Plug seal 5	199
Plug seal 6	199
Plug seal 6,5	200
Pneumatic 3-way distributor	438
Pneumatic end Plate 45 x 90	258
Pneumatic end Plate 90 x 90	259
Pneumatic Lifting unit 100	260
Pneumatic Lifting unit 15	259
Pneumatic Lifting unit 50	260
Pneumatic lift system PLS - 415	372
Positioner	532
Power outlet	430
Power-lock fastener 30 SF	76
Power-lock fastener 45 SF	76
Power-lock fastener 45 SF short	77
Power-lock fastener N 30	77
Power-lock fastener N 45	78
Profil 45 x 90 F	50
Profil 90 x 135	59
Profil 90 x 90 x 45	52
Profile 30 x 30	27
Profile 30 x 30 1G	28
Profile 30 x 30 G	27
Profile 16 x 30	25
Profile 19 X 90	48
Profile 19 x 32	33

Profile 19 x 45	33	Profile 45 X 45 UL 3G	42
Profile 23 x 16	25	Profile 45 X 60 F	53
Profile 23 x 23	26	Profile 45 X 90 G	51
Profile 23 x 30	26	Profile 45 X 90 S	51, 351
Profile 270 X 19	60, 376	Profile 45 X 90 UL	49
Profile 30 R 30°	30	Profile 45 x 135 F	54
Profile 30 R 45°	31	Profile 45 x 19	34
Profile 30 R 60°	31	Profile 45 x 45	38
Profile 30 R 90°	32	Profile 45 x 45 SST	43
Profile 30 x 30 2G	28	Profile 45 x 90	50
Profile 30 x 30 3G	29	Profile 45 x 90 2 G	52
Profile 30 x 60	29	Profile 45 / 22,5°	48
Profile 32 X 180	58	Profile 45 / 45°	47
Profile 32 X 32 F	35	Profile 60 X 60 F	53
Profile 32 X 32 UL	34	Profile 60 x 60 x 30	30
Profile 45 R 90°	45	Profile 90 R 90°	58
Profile 45 R 30°	47	Profile 90 X 180 S	59, 353
Profile 45 R 4	45	Profile 90 X 32 UL	49
Profile 45 R 45°	46	Profile 90 X 90 G	57
Profile 45 R 60°	46	Profile 90 X 90 S	56, 352
Profile 45 X 135 1G	54, 351	Profile 90 x 90 2 G	57
Profile 45 X 180 1G	55, 352	Profile 90 x 90 L	56
Profile 45 X 32 F	36	Profile 90 x 90 UL	55
Profile 45 X 32 UL	36	Profile height adjustment	44
Profile 45 X 45 1G	40	Protection cap cable duct 45 AL	237
Profile 45 X 45 2G	40	Protective field suspension 19	99
Profile 45 X 45 2GG	41	Protective field suspension 45 AL	100
Profile 45 X 45 3G	42	Protective field suspension 45 ST	99
Profile 45 X 45 F	38	Protective field suspension GD-K	100
Profile 45 X 45 G	39	Protective field suspension with adjustable angle	101
Profile 45 X 45 R	43	Proximity switch	530
Profile 45 X 45 UL	37	Proximity switch holder 12	245
Profile 45 X 45 UL 2GG	41	Proximity switch holder 18	245

Proximity switch holder 30	246
----------------------------	-----

Q

Quick connector 1/4	258
Quick connector 1/8	257
Quick label 27 x 75	420
Quick label 38 x 100	421

R

RAIL 45x180 H	301
RAIL 45x90 H	299
Rail 135 F	299
Rail 135 H	300
Rail 180 F	302
Rail 180 H	302
Rail 19	297
Rail 32	297
Rail 45	298
Rail 45x180 F	300
Rail 45x90 F	298
Rail 90	301
Rail holder	412
Rail LR 6 compact	296
Rail LR 6 S	296
Rail LR16 - 45x90H	303
Rail LR16 - 90	304
Rail LR16 - 90x180H	303
Ratchet handle 45 without lock	128
Ratchet handle 32 with lock	128
Ratchet handle 32 without profile cylinder lock	127
Ratchet handle 45 with lock	129
Ratchet handle 8	127
Recyclable material collector for attachment	425
Return stop	440

ROTARY LOCK 30	137
ROTARY LOCK 45	137
Roller carrier 25	508
Roller carrier 36	508
Roller carrier 45 x 45 R with cover	441
Roller carrier 45 x 45 R with SF cover	442
Roller carrier backing pads	441
Roller element for sliding door	229
Roller shutter with drive	231
Roller strip fastening	445
Roller wheel	228
Roller wheel S	228
Round rod	201
Round tool holder 38 - 120	417
Round tool holder 38-70	418

S

Safety catch for sliding door	230
Screw block 23	181
Screw block 30	181
Screw block 32	182
Screw block 45	182
Screw connection 32	80
Screw connection 45	79
Screw socket profile	189
Screwdriver holder	428
Screw-connection 30 N	79
Sealing Lip Profile	203
Sealing profile	203
Sealing strip	202
Security Switch AZ 16 ZVRK	232
Security switch with lock	234
Semi-open compartment base element	421
Semi-open compartment extension element	422

Semi-open compartment, single	422	Slide LR 6 compact	309
Set of bearings for conveyor rollers 25	506	Slide LW 32	311
Set of bearings for conveyor rollers 36	506	Slide LWG 32 x 45 - 45	341
Set of bearings S 25	507	Slide LWG 32 x 45 - 90	341
Set of bearings S 36	507	Slide LWG 45/45° - 45	340
SHAFT 20	354	Slide LWG 45/45°-90	340
Shaft 12	304	Slide LWN 32 x 45 - 45	339
Shaft 16	306	Slide LWN 32 x 45 - 90	339
Shaft D 20 for linear guide LB	355	Slide LWN 45/45° - 45	338
Shaft lock left LR16	307	Slide LWN 45/45° - 90	338
Shaft lock right LR16	307	Slide LWN-S	337
Shaft locking clip	305	Slide rail 23	207
Shaft support WB 180	350	Slide rail 8	206
Shaft support WB 45	348	Slide rail 8-40 A	206
Shaft support WB 45 x 135	349	Slide rail LG	342
Shaft support WB 45 x 180	349	Slide rail LN	342
Shaft support WB 90	350	Slide rail LN-S	343
Shaft supporting profile LR 12	305	Slide strip F	208
Shaft supporting profile LR 16 without bore	306	Slide strip R	207
Side guide 40 F white	514	Slide LR 6	309
Signal Profile	196	Slide LR 6 Z	310
SLIDE ELEMENT	226	Slide LR 6 Z compact	308
SLIDE LB 180	348	Slide LW 135	313
SLIDE LB 45	346	Slide LW 180 with 8 bearings	314
SLIDE LB 45 x 135	346	Slide LW 32 E	311
SLIDE LB 45 x 180	347	Slide LR 16 - 45	314
SLIDE LB 90	347	Slide LR 16 - 90	315
SLIDE-ROLL ELEMENT	224	Slide LR 6 compact	308
Slewing Ring 330 / 260 / 14 mm	457	Slide LR 6 with cover	310
Slide Bar 8 N 30	205	Slide LW 180	313
Slide Bar 8 N 45	205	Slide LW 45	312
Slide clamping unit (Top) LWG / LWN / LW	322	Slide LW 90	312
Slide G 32	337	SNAP BOLT 25	141

SNAP BOLT 40	142
Socket strip Alu 3-fold	432
Socket strip Alu 6-fold	432
Socket strip Alu 8-fold	433
Socket strips 7-fold	431
Sound absorption plate 20mm	569
Sound absorption plate pyramid	569
Spacer	509
Spiral cable highly elastic	462
STOPPER	529
STOPPER 25	145
STOPPER 30	146
STOPPER 40	146
STRENGTHENING ELEMENT 30	166
STRENGTHENING ELEMENT 30 x 60	167
Steel bracket 250	418
Steel bracket 400	419
Step drill	581
Storage box holder	401
Storage box shelf	401
Storage console with clamping lever	406
Storage shelf / monitor support rotating CRT	406
Strengthening element 45	167
Strengthening element 45 VA	168
Strengthening element 90	168
Strut socket 45 GD	162
Strut socket 45°/90	163
Support Bearing 20	516
Support profile F	186
Support profile N	186
Support roller conveyor belt	502
Supporting foot 45 GD	169
Supporting foot 45 GD open	170

Supporting foot 45 GD S	171
Supporting foot 90 GD	171
Supporting foot 90 S	172
Swing-out hinge	112
Swivel arm ECO	415
Swivel cantilever C-rail 30	414
Swivel caster with wheel lock D75 x 100, conductive	470
Swivel caster without wheel lock D75 x 100, conductive	470
Swivel castor with brake D100 x 135, ESD	471
Swivel castor without brake D100 x 135, ESD	471
Swivel holder	427
Swivel Joint 45	114
Swivel joint 45	115
Swivel joint 45 with clamping lever	115
Swivel joint 45/15	116
Swivel plate	501
Swivelling castor with brake D 100 x 131	157
Swivelling castor with brake D 75 x 100	154
Swivelling castor without brake D 100 x 131	158
Swivelling castor without brake D 75 x 100	155
Synchronous reverse unit 45	214

T

Telescopic guide full extension 400	384
THREAD FORMER M8	580
THREAD FORMING MACHINE	582
Thread forming and drilling machine	582
Thread Socket GD	184
TIMING BELT	533
Timing belt 16 AT 5	285
Timing belt 32 AT 10	286
Timing belt pulley T45 Z	327
Timing belt reverse unit T 90 Z	327
Timing belt tensioner	286

Timing belt tensioner reinforced to carriage LW90	287
Toggle handle 19	129
Toggle handle 32	130
Toggle handle 45	130
Toggle switch	431
Toggle switch/power outlet	430
Tool case S	426
Tool case S as set	425
Tool slide	411
Tool slider H	410
Tool trolley	413
Toothed rack 8	287
Torque support WA 10	499
Torque support WA 20	499
Torque support WA 30	500
Track profile	229
Transport aid	173
Transport roller 50-25	503
Transport roller 50-36	503
Transport roller S 50-25	504
Transport roller S 50-36	504
Trunk lock compact	138
Trunk lock with an inquiry	138
Turning device 45 x 90	456
Turning device 90x90	456
Twist protection F	131
T-Handle key torx T40	575
T-handle key ball head	577
T-handle key with cross-handle	576
T-Sheet SST	95
T-slot bar 135	83
T-slot bar 140	83
T-slot bar 180	84

T-slot bar 90	82
T-slot bar profile	84

U

Universal clamping socket	458
Universal deburrer with S - blade	584
Universal holder	398
Upright bearing	119
U-BAR FOR SLIDING DOOR	231
U-Profile	202

V

Vertical double outlet	429
------------------------	-----

W

Waste separation	424
WORKPIECE TRAY 200	531



MiniTec-Partners

Canada | USA | Venezuela | Brazil | Great Britain | France | Portugal | Spain | Italy | Belgium | Netherlands
Luxembourg | Denmark | Sweden | Finland | Latvia | Estonia | Lithuania | Poland | Belarus | Russia | Switzerland
Austria | Hungary | Romania | Czech Republic | Slovenia | Slovakia | Croatia | Serbia | Bosnia | Macedonia
Greece | Turkey | Israel | South Africa | India | Japan | Singapore | China | Australia | New Zealand